

GUJARAT TECHNOLOGICAL UNIVERSITY**BE – SEMESTER- V EXAMINATION-SUMMER 2023****Subject Code: 3151911****Date: 03/07/2023****Subject Name: Dynamics of Machinery****Time: 02:30 PM TO 05:00 PM****Total Marks: 70****Instructions:**

1. Attempt all questions.
2. Make suitable assumptions wherever necessary.
3. Figures to the right indicate full marks.
4. Simple and non-programmable scientific calculators are allowed

MARKS

- Q.1**
- (a) Explain the effect of gyroscopic couple on naval ship. **03**
- (b) Explain the difference between piston effort, crank effort and crank-pin effort. **04**
- (c) The three cranks of a three-cylinder locomotive are all on the same axle and are set at 120° . The pitch of the cylinders is 1 metre and the stroke of each piston is 0.6 m. The reciprocating masses are 300 kg for inside cylinder and 260 kg for each outside cylinder and the planes of rotation of the balance masses are 0.8 m from the inside crank. If 40% of the reciprocating parts are to be balanced, find the magnitude and the position of the balancing masses required at a radius of 0.6 m. **07**
- Q.2**
- (a) Define the terms: i) magnification factor, ii) force transmissibility, iii) relative amplitude. **03**
- (b) Explain the terms ‘fluctuation of energy’ and ‘fluctuation of speed’ as applied to flywheels. **04**
- (c) Find the natural frequency of the given system given in the figure 2.1. **07**

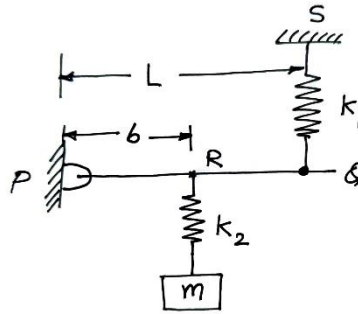

Figure 2.1

OR

- (c) In a slider crank mechanism, the length of the crank and connecting rod are 150 mm and 600 mm respectively. The crank position is 60° from inner dead center. The crank shaft speed is 450 r.p.m. (clockwise). Using analytical method, determine: 1. Velocity and acceleration of the slider, and 2. Angular velocity and angular acceleration of the connecting rod. **07**
- Q.3**
- (a) Derive an expression of swaying couple for an uncoupled two-cylinder locomotive engine. **03**
- (b) Explain the method of balancing of inline engines. **04**

- (c) Four masses P, Q, R and S as shown below are to be completely balanced. 07

| | P | Q | R | S |
|-------------|-----|-----|-----|-----|
| Mass (Kg) | --- | 30 | 50 | 40 |
| Radius (mm) | 180 | 240 | 120 | 150 |

The planes containing masses Q and R are 300 mm apart. The angle between planes containing Q and R is 90° . Q and R make angles of 210° and 120° respectively with S in the same sense. Find:

1. The magnitude and the angular position of mass P; and
2. The position of planes P and S.

OR

- Q.3** (a) Derive an expression for time period of damped vibration. 03
 (b) Explain with neat sketch working of any one frequency measuring instrument. 04
 (c) A vibratory body of mass 150 Kg supported on springs of total stiffness 1050 KN/m and has a rotating unbalance of 525 N at a speed of 6000 rpm. If the damping factor is 0.3, determine; 07
- i) the amplitude caused by the unbalance,
 - ii) the transmissibility
 - iii) the actual force transmitted and its phase angle.

- Q.4** (a) State the D'Alembert's principle and explain any one application of it. 03
 (b) Explain the turning moment diagram of a four stroke cycle internal combustion engine. 04
 (c) A single cylinder double acting steam engine develops 150 kW at a mean speed of 80 r.p.m. The coefficient of fluctuation of energy is 0.1 and the fluctuation of speed is $\pm 2\%$ of mean speed. If the mean diameter of the flywheel rim is 2 meter and the hub and spokes provide 5% of the rotational inertia of the flywheel, find the mass and cross-sectional area of the flywheel rim. Assume the density of the flywheel material made of cast iron as 7200 kg/m^3 . 07

OR

- Q.4** (a) Define the terms: i) Natural frequency, ii) damping, iii) mechanical vibrations 03
 (b) Derive an expression for equation of motion of critically-damped system. 04
 (c) Determine the damping constant of the particular viscous system for the following data; 07
- Amplitude of second cycle = 12 mm
 Amplitude of third cycle = 10.5 mm
 Spring constant = 800 N/m
 Weight on spring = 2 Kg.

- Q.5** (a) Differentiate between static balancing and dynamic balancing. 03
 (b) What do you understand by gyroscopic couple? Derive a formula for its magnitude. 04
 (c) A four wheeled motor car of mass 2000 kg has a wheel base 2.5 m, track width 1.5 m and height of centre of gravity 500 mm above the ground level and lies at 1 metre from the front axle. Each wheel has an effective diameter of 0.8 m and a moment of inertia of 0.8 kg-m^2 . The drive shaft, engine flywheel and transmission are rotating at 4 times the speed of road wheel, in a clockwise direction when viewed from the front, and is equivalent to a mass of 75 kg having a radius of gyration of 100 mm. If the car is taking a right turn of 60 m radius at 60 km/h, find the load on each wheel. 07

OR

- Q.5** (a) State different ways of providing the damping and explain any one in detail. 03
 (b) Derive an expression for torsionally equivalent shaft system. 04
 (c) A vertical shaft is held between the long bearings and a disc is attached to the shaft at its mid-point. The center of gravity of the disc does not coincide with the axis of the shaft. The diameter of the shaft is 15 mm and the span of the shaft between two 07

bearings is 1 meter. The mass of the disc is 10 Kg and the center of the gravity of the disc is 0.3 mm from the axis of the shaft. Take $E = 200 \text{ GN/m}^2$ and permissible stress in the shaft material as $70 * 10^6 /\text{m}^2$.

Determine the critical speed of the shaft and the range of the speed over which it is unsafe to run the shaft.
