

# **ELECTRICAL CIRCUIT ANALYSIS**

## **Lecture Notes**

**(2021-22)**

**Prepared By**

**KARIMULLA PEERLA SHAIK**

**Associate Professor, Department of EEE**



**Department of Electrical & Electronics Engineering**

**Malla Reddy College of Engineering & Technology**

**Maisammaguda, Dhullapally, Secunderabad-500100**

---

**MALLA REDDY COLLEGE OF ENGINEERING AND TECHNOLOGY**
**II Year B.Tech EEE-I Sem**

<b>L</b>	<b>T/P/D</b>	<b>C</b>
<b>3</b>	<b>-/-/-</b>	<b>3</b>

**(R20A0206) ELECTRICAL CIRCUIT ANALYSIS**
**COURSE OBJECTIVES:**

- This course introduces the analysis of transients in electrical systems, to understand three phase circuits, to evaluate network parameters of given electrical network, to draw the locus diagrams and to know about the network functions
- To prepare the students to have a basic knowledge in the analysis of Electric Networks

**UNIT-I**

**D.C TRANSIENT ANALYSIS:** Transient response of R-L, R-C, R-L-C circuits (Series and parallel combinations) for D.C. excitations, Initial conditions, Solution using differential equation and Laplace transform method.

**UNIT - II**

**A.C TRANSIENT ANALYSIS:** Transient response of R-L, R-C, R-L-C Series circuits for sinusoidal excitations, Initial conditions, Solution using differential equation and Laplace transform method.

**UNIT - III**

**THREE PHASE CIRCUITS:** Phase sequence, Star and delta connection, Relation between line and phase voltages and currents in balanced systems, Analysis of balanced and Unbalanced three phase circuits

**UNIT – IV**

**LOCUS DIAGRAMS & RESONANCE:** Series and Parallel combination of R-L, R-C and R-L-C circuits with variation of various parameters. Resonance for series and parallel circuits, concept of bandwidth and Q factor.

**UNIT - V**

**NETWORK PARAMETERS:** Two port network parameters – Z,Y, ABCD and hybrid parameters. Condition for reciprocity and symmetry-Conversion of one parameter to other- Interconnection of Two port networks in series, parallel and cascaded configuration and image parameters.

**TEXT BOOKS:**

1. William Hart Hayt, Jack Ellsworth Kemmerly, Steven M. Durbin (2007), Engineering Circuit Analysis, 7th edition, McGraw-Hill Higher Education, New Delhi, India
2. Joseph A. Edminister (2002), Schaum's outline of Electrical Circuits, 4th edition, Tata McGraw Hill Publications, New Delhi, India.
3. A. Sudhakar, Shyam Mohan S. Palli (2003), Electrical Circuits, 2nd Edition, Tata McGraw Hill, New Delhi

**REFERENCE BOOKS:**

1. C. L. Wadhwa(2008), Electric Circuits Analysis, 2 nd edition, New Age International Publications, New Delhi.
2. A.Chakrabarthy(2010), Circuit Theory, 5th edition, Dhanpat Rai & Sons Publications, New Delhi.
3. Van Valkenburg, M. E. (1974), Network Analysis, 3rd Edition, Prentice Hall of India, New Delhi.
4. A Text Book on Electrical Technology. –B L THERAJA, Vol 1, S.Chand Publications.

**COURSE OUTCOMES:**

After going through this course the student gets thorough knowledge on basic parameters of two port network.

- Will be able to articulate in working of various components of a circuit.
- Will be familiar with ac and dc circuit solving.
- Ability to measure Three phase voltages and current, active, reactive powers
- Ability to convert Three phase Star to Three phase Delta circuits and Vice-Versa.

# **Electrical Circuit Analysis:: Lecture Notes**

## **Contents**

**Unit-1 : D.C Transient Analysis**

**Unit-2 : A.C Transient Analysis**

**Unit-3 : Three Phase Circuits**

**Unit-4 : Locus Diagrams & Resonance**

**Unit-5 : Network Parameters**

## **UNIT-1**

### **TRANSIENT ANALYSIS (FIRST AND SECOND ORDER CIRCUITS)**

- **Introduction**
- **Transient Response of RL, RC series and RLC circuits for DC excitations**
- **Initial conditions**
- **Solution using Differential equations approach**
- **Solution using Laplace transformation**
  - **Summary of Important formulae and Equations**
  - **Illustrative examples**

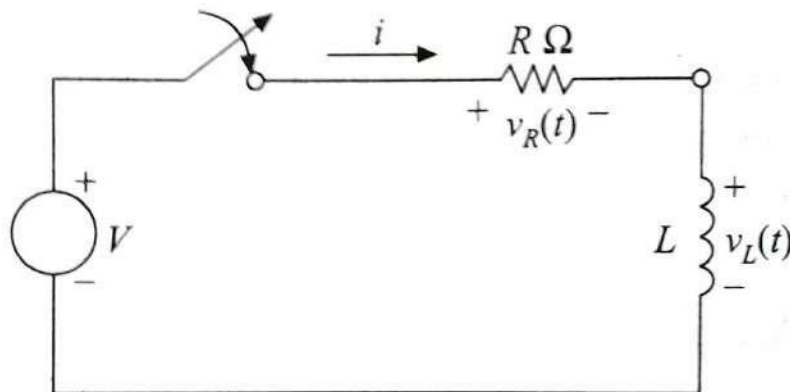
**Introduction:**

In this chapter we shall study transient response of the RL, RC series and RLC circuits with external DC excitations. Transients are generated in Electrical circuits due to abrupt changes in the operating conditions when energy storage elements like Inductors or capacitors are present. Transient response is the dynamic response during the initial phase before the steady state response is achieved when such abrupt changes are applied. To obtain the transient response of such circuits we have to solve the differential equations which are the governing equations representing the electrical behavior of the circuit. A circuit having a single energy storage element i.e. either a capacitor or an Inductor is called a Single order circuit and it's governing equation is called a First order Differential Equation. A circuit having both Inductor and a Capacitor is called a Second order Circuit and it's governing equation is called a Second order Differential Equation. The variables in these Differential Equations are currents and voltages in the circuit as a function of time.

A solution is said to be obtained to these equations when we have found an expression for the dependent variable that satisfies both the differential equation and the prescribed initial conditions. The solution of the differential equation represents the **Response** of the circuit. Now we will find out the response of the basic RL and RC circuits with DC Excitation.

**RL CIRCUIT with external DC excitation:**

Let us take a simple RL network subjected to external DC excitation as shown in the figure. The circuit consists of a battery whose voltage is  $V$  in series with a switch, a resistor  $R$ , and an inductor  $L$ . The switch is closed at  $t = 0$ .



**Fig: RL Circuit with external DC excitation**

When the switch is closed current tries to change in the inductor and hence a voltage  $V_L(t)$  is induced across the terminals of the Inductor in opposition to the applied voltage. The rate of change of current decreases with time which allows current to build up to it's maximum value.

It is evident that the current  $i(t)$  is zero before  $t = 0$ , and we have to find out current  $i(t)$  for time  $t > 0$ . We will find  $i(t)$  for time  $t > 0$  by writing the appropriate circuit equation and then solving it by separation of the variables and integration.

Applying Kirchhoff's voltage law to the above circuit we get :

$$V = v_R(t) + v_L(t)$$

$$i(t) = 0 \text{ for } t < 0$$

Using the standard relationships of Voltage and Current for the Resistors and Inductors we can rewrite the above equations as

$$V = Ri + L \frac{di}{dt} \text{ for } t > 0$$

One direct method of solving such a differential equation consists of writing the equation in such a way that the variables are separated, and then integrating each side of the equation. The variables in the above equation are  $i$  and  $t$ . This equation is multiplied by  $dt$  and arranged with the variables separated as shown below:

$$Ri \cdot dt + L di = V \cdot dt$$

$$\text{i.e } L di = (V - Ri) dt$$

$$\text{i.e } L di / (V - Ri) = dt$$

Next each side is integrated directly to get :

$$- (L/R) \ln(V - Ri) = t + k$$

Where  $k$  is the integration constant. In order to evaluate  $k$ , an initial condition must be invoked. Prior to  $t = 0$ ,  $i(t)$  is zero, and thus  $i(0^-) = 0$ . Since the current in an inductor cannot change by a finite amount in zero time without being associated with an infinite voltage, we have  $i(0^+) = 0$ . Setting  $i = 0$  at  $t = 0$ , in the above equation we obtain

$$- (L/R) \ln(V) = k$$

and, hence,

$$- L/R [\ln(V - Ri) - \ln V] = t$$

Rearranging we get

$$\ln[(V - Ri) / V] = - (R/L)t$$

Taking antilogarithm on both sides we get

$$(V - Ri) / V = e^{-Rt/L}$$

From which we can see that

$$i(t) = (V/R) - (V/R)e^{-Rt/L} \text{ for } t > 0$$

Thus, an expression for the response valid for all time  $t$  would be

$$i(t) = V/R [1 - e^{-Rt/L}]$$

This is normally written as:

$$i(t) = V/R [1 - e^{-t/\tau}]$$

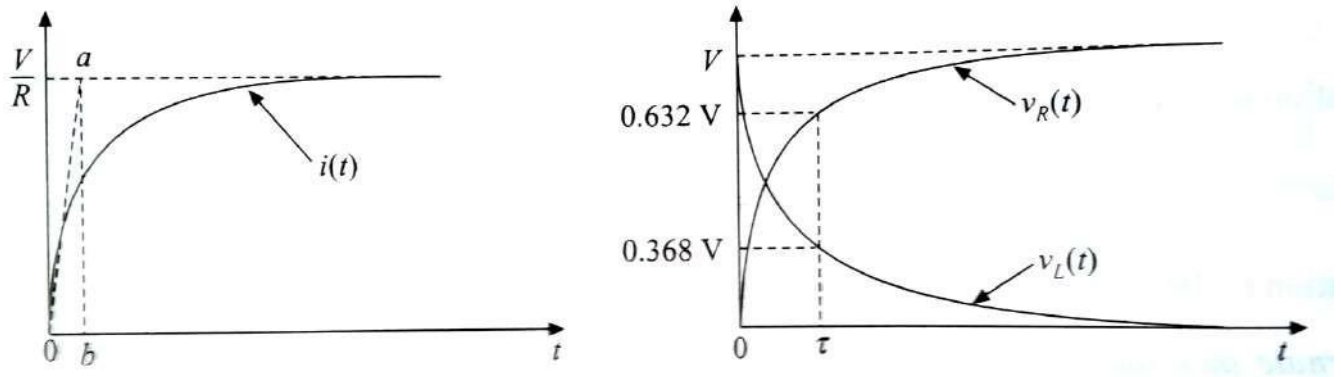
where ' $\tau$ ' is called the **time constant** of the circuit and its unit is seconds.

The voltage across the **resistance** and the **Inductor** for  $t > 0$  can be written as :

$$v_R(t) = i(t) \cdot R = V [1 - e^{-t/\tau}]$$

$$v_L(t) = V - v_R(t) = V - V [1 - e^{-t/\tau}] = V (e^{-t/\tau})$$

A plot of the current  $i(t)$  and the voltages  $v_R(t)$  &  $v_L(t)$  is shown in the figure below.



**Fig: Transient current and voltages in the Series RL circuit.**

At  $t = \tau$  the voltage across the inductor will be

$$v_L(\tau) = V (e^{-\tau/\tau}) = V/e = 0.36788 V$$

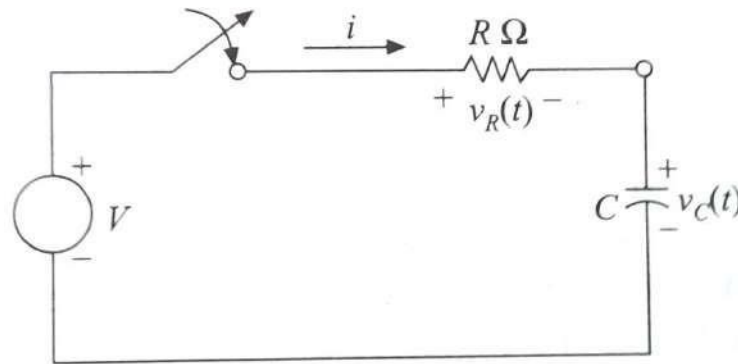
and the voltage across the Resistor will be  $v_R(\tau) = V [1 - e^{-\tau/\tau}] = 0.63212 V$

The plots of current  $i(t)$  and the voltage across the Resistor  $v_R(t)$  are called **exponential growth** curves and the voltage across the inductor  $v_L(t)$  is called **exponential decay** curve.

#### **RCCIRCUIT with external DC excitation:**

A series RC circuit with external DC excitation  $V$  volts connected through a switch is shown in the figure below. If the capacitor is not charged initially i.e. its voltage is zero, then after the switch  $S$  is closed at time  $t=0$ , the capacitor voltage builds up gradually and reaches its steady state value of  $V$  volts after a finite time. The charging current will be maximum initially (since initially capacitor voltage is zero and voltage across a capacitor cannot change instantaneously) and then it will gradually come down as the capacitor voltage starts building up. The current and the voltage during such charging periods are called Transient Current and Transient Voltage.





**Fig: RC Circuit with external DC excitation**

Applying KVL around the loop in the above circuit we can write

$$V = v_R(t) + v_C(t)$$

Using the standard relationships of voltage and current for an Ideal Capacitor we get

$$v_C(t) = (1/C) \int i(t) dt \text{ or } i(t) = C.[dv_C(t)/dt]$$

and using this relation,  $v_R(t)$  can be written as  $v_R(t) = Ri(t) = R.C.[dv_C(t)/dt]$

Using the above two expressions for  $v_R(t)$  and  $v_C(t)$  the above expression for  $V$  can be rewritten as :

$$V = R.C.[dv_C(t)/dt] + v_C(t)$$

$$\text{Or finally } dv_C(t)/dt + (1/RC). v_C(t) = V/RC$$

The inverse coefficient of  $v_C(t)$  is known as the time constant of the circuit  $\tau$  and is given by  $\tau = RC$  and its units are seconds.

The above equation is a first order differential equation and can be solved by using the same method of **separation of variables** as we adopted for the LC circuit.

Multiplying the above equation  $dv_C(t)/dt + (1/RC). v_C(t) = V/RC$

both sides by 'dt' and rearranging the terms so as to separate the variables  $v_C(t)$  and  $t$  we get:

$$dv_C(t) + (1/RC). v_C(t) . dt = (V/RC). dt$$

$$dv_C(t) = [(V/RC) - (1/RC). v_C(t)]. dt$$

$$dv_C(t) / [(V/RC) - (1/RC). v_C(t)] = dt$$

$$R.C. dv_C(t) / [(V - v_C(t))] = dt$$

Now integrating both sides w.r.t their variables i.e. ' $v_c(t)$ ' on the LHS and ' $t$ ' on the RHS we get

$$-RC \ln [V - v_c(t)] = t + k$$

where ' $k$ ' is the constant of integration. In order to evaluate  $k$ , an initial condition must be invoked. Prior to  $t = 0$ ,  $v_c(t)$  is zero, and thus  $v_c(t)(0^-) = 0$ . Since the voltage across a capacitor cannot change by a finite amount in zero time, we have  $v_c(t)(0^+) = 0$ . Setting  $v_c(t) = 0$  at  $t = 0$ , in the above equation we obtain:

$$-RC \ln [V] = k$$

and substituting this value of  $k = -RC \ln [V]$  in the above simplified equation  $-RC \ln [V - v_c(t)] = t + k$  we get :

$$-RC \ln [V - v_c(t)] = t - RC \ln [V]$$

$$\text{i.e. } -RC \ln [V - v_c(t)] + RC \ln [V] = t \quad \text{i.e. } -RC [\ln \{V - v_c(t)\} - \ln (V)] = t$$

$$\text{i.e. } [\ln \{V - v_c(t)\}] - \ln [V] = -t/RC$$

$$\text{i.e. } \ln \{[V - v_c(t)]/V\} = -t/RC$$

Taking anti logarithm we get  $\{[V - v_c(t)]/V\} = e^{-t/RC}$

$$\text{i.e. } v_c(t) = V(1 - e^{-t/RC})$$

which is the voltage across the capacitor as a function of time .

$$\text{The voltage across the Resistor is given by : } v_R(t) = V - v_c(t) = V - V(1 - e^{-t/RC}) = V.e^{-t/RC}$$

$$\text{And the current through the circuit is given by: } i(t) = C.[dv_c(t)/dt] = (CV/CR)e^{-t/RC} = (V/R)e^{-t/RC}$$

$$\text{Or the othe other way: } i(t) = v_R(t) / R = (V.e^{-t/RC}) / R = (V/R)e^{-t/RC}$$

In terms of the time constant  $\tau$  the expressions for  $v_c(t)$ ,  $v_R(t)$  and  $i(t)$  are given by :

$$v_c(t) = V(1 - e^{-t/RC})$$

$$v_R(t) = V.e^{-t/RC}$$

$$i(t) = (V/R)e^{-t/RC}$$

The plots of current  $i(t)$  and the voltages across the resistor  $v_R(t)$  and capacitor  $v_c(t)$  are shown in the figure below.

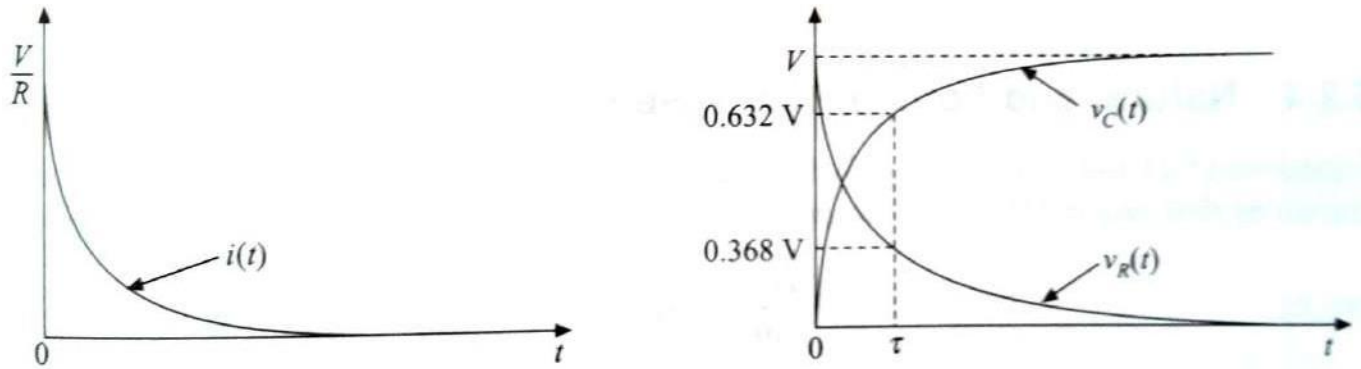


Fig : Transient current and voltages in RC circuit with DC excitation.

At  $t = \tau$  the voltage across the capacitor will be:

$$v_C(\tau) = V [1 - e^{-\tau/\tau}] = 0.63212 V$$

the voltage across the Resistor will be:

$$v_R(\tau) = V (e^{-\tau/\tau}) = V/e = 0.36788 V$$

and the current through the circuit will be:

$$i(\tau) = (V/R) (e^{-\tau/\tau}) = V/R \cdot e = 0.36788 (V/R)$$

Thus it can be seen that after one time constant the charging current has decayed to approximately 36.8% of its value at  $t=0$ . At  $t = 5\tau$  charging current will be

$$i(5\tau) = (V/R) (e^{-5\tau/\tau}) = V/R \cdot e^{-5} = 0.0067(V/R)$$

This value is very small compared to the maximum value of  $(V/R)$  at  $t=0$ . Thus it can be assumed that the capacitor is fully charged after 5 time constants.

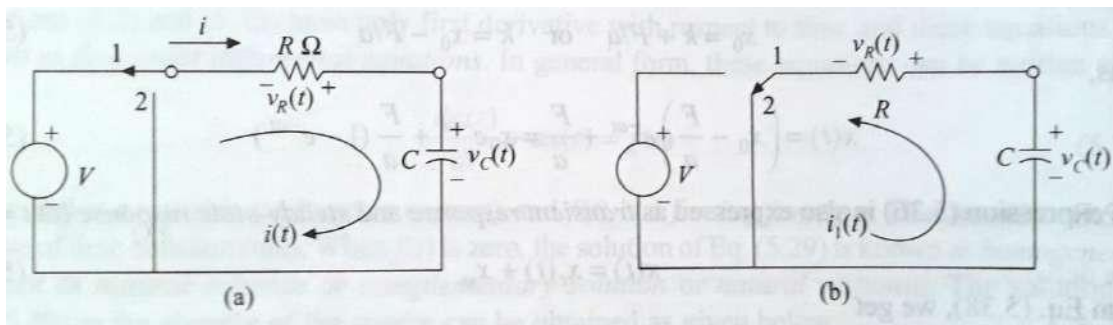
The following similarities may be noted between the equations for the transients in the LC and RC circuits:

- The transient voltage across the Inductor in a LC circuit and the transient current in the RC circuit have the same form  $k \cdot (e^{-t/\tau})$
- The transient current in a LC circuit and the transient voltage across the capacitor in the RC circuit have the same form  $k \cdot (1 - e^{-t/\tau})$

But the main difference between the RC and RL circuits is the effect of resistance on the duration of the transients.

- In a RL circuit a large resistance shortens the transient since the time constant  $\tau = L/R$  becomes small.
- Whereas in a RC circuit a large resistance prolongs the transient since the time constant  $\tau = RC$  becomes large.

**Discharge transients:** Consider the circuit shown in the figure below where the switch allows both charging and discharging the capacitor. When the switch is position 1 the capacitor gets charged to the applied voltage  $V$ . When the switch is brought to position 2, the current discharges from the positive terminal of the capacitor to the negative terminal through the resistor  $R$  as shown in the figure (b). The circuit in position 2 is also called **source free circuit** since there is no any applied voltage.



**Fig: RC circuit (a) During Charging (b) During Discharging**

The current  $i_1$  flow is in opposite direction as compared to the flow of the original charging current  $i$ . This process is called the *discharging of the capacitor*. The decaying voltage and the current are called the *discharge transients*. The resistor, during the discharge will oppose the flow of current with the polarity of voltage as shown. Since there is no any external voltage source, the algebraic sum of the voltages across the Resistance and the capacitor will be zero (applying KVL). The resulting loop equation during the discharge can be written as

$$v_R(t) + v_C(t) = 0 \quad \text{or} \quad v_R(t) = -v_C(t)$$

We know that  $v_R(t) = R \cdot i(t) = R \cdot C \cdot dv_C(t) / dt$ . Substituting this in the first loop equation we get

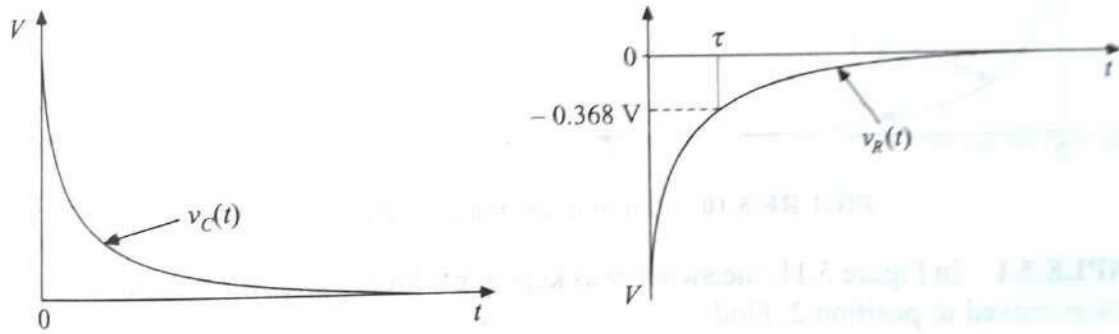
$$R \cdot C \cdot dv_C(t) / dt + v_C(t) = 0$$

The solution for this equation is given by  $v_C(t) = K e^{-t/\tau}$  where  $K$  is a constant decided by the initial conditions and  $\tau = RC$  is the time constant of the RC circuit

The value of  $K$  is found out by invoking the initial condition  $v_C(t) = V$  @  $t = 0$

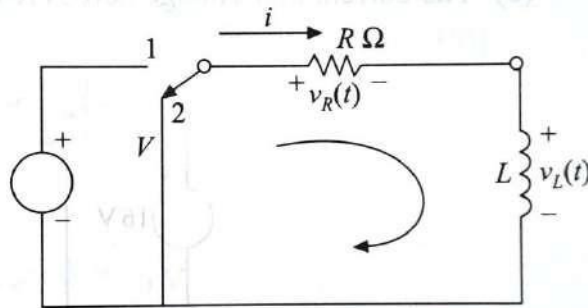
Then we get  $K = V$  and hence  $v_C(t) = V e^{-t/\tau}$ ;  $v_R(t) = -V e^{-t/\tau}$  and  $i(t) = v_R(t)/R = (-V/R) e^{-t/\tau}$

The plots of the voltages across the Resistor and the Capacitor are shown in the figure below.



**Fig: Plot of Discharge transients in RC circuit**

**Decay transients:** Consider the circuit shown in the figure below where the switch allows both growing and decaying of current through the Inductance . When the switch is position 1 the current through the Inductance builds up to the steady state value of  $V/R$ . When the switch is brought to position 2, the current decays gradually from  $V/R$  to zero. The circuit in position 2 is also called a **source free circuits** since there is no any applied voltage.



**Fig: Decay Transient In RL circuit**

The current flow during decay is in the same direction as compared to the flow of the original growing /build up current. The decaying voltage across the Resistor and the current are called the *decay transients*.. Since there is no any external voltage source ,the algebraic sum of the voltages across the Resistance and the Inductor will be zero (applying KVL) .The resulting loop equation during the discharge can be written as

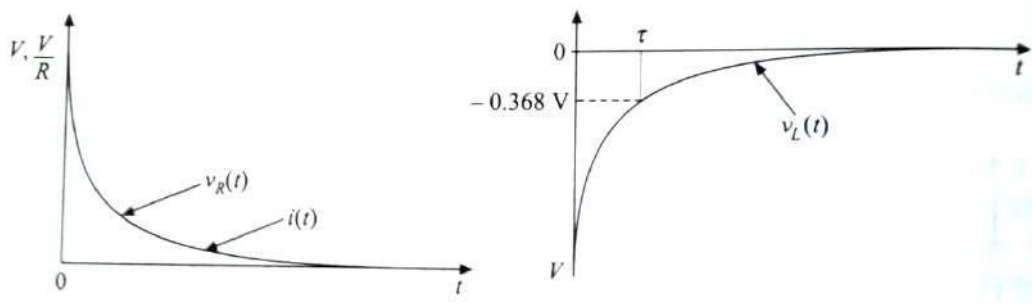
$$v_R(t) + v_L(t) = R \cdot i(t) + L \cdot di(t)/dt = 0 \quad \text{and} \quad v_R(t) = -v_L(t)$$

The solution for this equation is given by  $i(t) = Ke^{-t/\tau}$  where K is a constant decided by the initial conditions and  $\tau = L/R$  is the time constant of the RL circuit.

The value of the constant K is found out by invoking the initial condition  $i(t) = V/R$  @  $t = 0$

Then we get  $K = V/R$  and hence  $i(t) = (V/R) \cdot e^{-t/\tau}$  ;  $v_R(t) = R \cdot i(t) = Ve^{-t/\tau}$  and  $v_L(t) = -Ve^{-t/\tau}$

The plots of the voltages across the Resistor and the Inductor and the decaying current through the circuit are shown in the figure below.



**Fig: Plot of Decay transients in RL circuit**

### The Concept of Natural Response and forced response:

The **RL** and **RC** circuits we have studied are with external DC excitation. These circuits without the external DC excitation are called **source free circuits** and their Response obtained by solving the corresponding differential equations is known by many names. Since this response depends on the general **nature** of the circuit (type of elements, their size, their interconnection method etc.,) it is often called a **Natural response**. However any real circuit we construct cannot store energy forever. The resistances intrinsically associated with Inductances and Capacitors will eventually dissipate the stored energy into heat. The response eventually dies down,. Hence it is also called **Transient response**. As per the mathematician's nomenclature the solution of such a homogeneous linear differential equation is called **Complementary function**.

When we consider independent sources acting on a circuit, part of the response will resemble the nature of the particular source. (Or forcing function) This part of the response is called **particular solution** , **the steady state response** or **forced response**. This will be complemented by the complementary function produced in the source free circuit. The complete response of the circuit is given by the sum of the **complementary function** and the **particular solution**. In other words:

$$\text{The Complete response} = \text{Natural response} + \text{Forced response}$$

There is also an excellent mathematical reason for considering the complete response to be composed of two parts—the **forced response** and the **natural response**. The reason is based on the fact that the solution of any linear differential equation may be expressed as the sum of two parts: the **complementary solution**(natural response) and the **particular solution**(forced response).

### Determination of the Complete Response:

Let us use the same **RL**series circuit with external DC excitation to illustrate how to determine the complete response by the addition of the natural and forced responses. The circuit shown in the figure

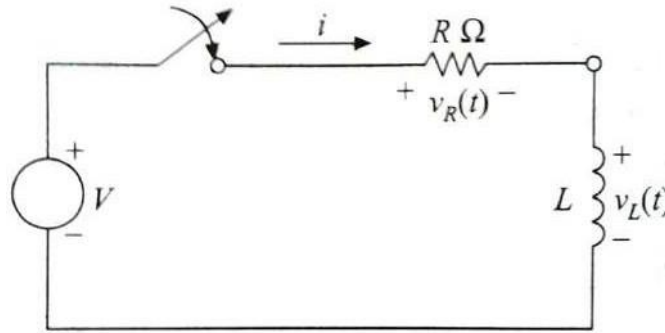


Fig: RL circuit with external DC excitation

was analyzed earlier, but by a different method. The desired response is the current  $i(t)$ , and now we first express this current as the sum of the natural and the forced current,

$$i = i_n + i_f$$

The functional form of the natural response must be the same as that obtained without any sources. We therefore replace the step-voltage source by a short circuit and call it the **RL source free** series loop. And  $i_n$  can be shown to be :

$$i_n = Ae^{-Rt/L}$$

where the amplitude  $A$  is yet to be determined; since the initial condition applies to the **complete** response, we cannot simply assume  $A = i(0)$ . We next consider the forced response. In this particular problem the forced response is constant, because the source is a constant  $V$  for all positive values of time. After the natural response has died out, there can be no voltage across the inductor; hence the all the applied voltage  $V$  appears across  $R$ , and the forced response is simply

$$i_f = V/R$$

Note that the forced response is determined completely. There is no unknown amplitude. We next combine the two responses to obtain :

$$i = Ae^{-Rt/L} + V/R$$

And now we have to apply the initial condition to evaluate  $A$ . The current is zero prior to  $t = 0$ , and it cannot change value instantaneously since it is the current flowing through an inductor. Thus, the current is zero immediately after  $t = 0$ , and

$$A + V/R = 0$$

So that

$$A = -V/R$$

$$\text{And } i = (V/R)(1 - e^{-Rt/L})$$

Note carefully that  $A$  is not the initial value of  $i$ , since  $A = -V/R$ , while  $i(0) = 0$ .

**But In source-free circuits,  $A$  would be the initial value of the response given by  $i_n = i_0 e^{-Rt/L}$  ( where  $i_0 = A$  is the current at time  $t=0$  ). When forcing functions are present, however, we must first find the initial value of the complete response and then substitute this in the equation for the complete response to find  $A$ . Then this value of  $A$  is substituted in the expression for the total response  $i$**

**Amoregeneral solutionapproach:**

The method of solving the differential equation by separating the variables or by evaluating the complete response as explained above may not be possible always. In such cases we will rely on a very powerful method, the success of which will depend upon our intuition or experience. We simply guess or assume a form for the solution and then test our assumptions, first by substitution in the differential equation, and then by applying the given initial conditions. Since we cannot be expected to guess the exact numerical expression for the solution, we will assume a solution containing several unknown constants and select the values for these constants in order to satisfy the differential equation and the initial conditions.

Many of the differential equations encountered in circuit analysis have a solution which may be represented by the exponential function or by the sum of several exponential functions. Hence Let us assume a solution for the following equation corresponding to a source free RL circuit

$$[ di/dt + (R/L)i ] = 0$$

in exponential form as

$$i(t) = A.e^{s_1 t}$$

where **A** and **s<sub>1</sub>** are constants to be determined. Now substituting this assumed solution in the original governing equation we have:

$$A \cdot s_1 \cdot e^{s_1 t} + A \cdot e^{s_1 t} \cdot R/L = 0$$

Or

$$(s_1 + R/L) \cdot A \cdot e^{s_1 t} = 0$$

In order to satisfy this equation for all values of time, it is necessary that **A = 0**, or **s<sub>1</sub> = -∞**, or **s<sub>1</sub> = -R/L**. But if **A = 0** or **s<sub>1</sub> = -∞**, then every response is zero; neither can be a solution to our problem. Therefore, we must choose

$$s_1 = -R/L$$

And our assumed solution takes on the form:

$$i(t) = A \cdot e^{-Rt/L}$$

The remaining constant must be evaluated by applying the initial condition **i(0) = I<sub>0</sub>**. Thus, **A = I<sub>0</sub>**, and the final form of the assumed solution is (again):

$$i(t) = I_0 \cdot e^{-Rt/L}$$

**A Direct Route: The Characteristic Equation:**

In fact, there is a more direct route that we can take. To obtain the solution for the first order DE we solve **s<sub>1</sub> + R/L = 0** which is known as the **characteristic equation** and then substituting this value of **s<sub>1</sub> = -R/L** in the assumed solution **i(t) = A.e<sup>s<sub>1</sub>t</sup>** which is same in this direct method also. We can obtain the characteristic equation directly from the differential equation, without the need for substitution of our trial solution. Consider the general first-order differential equation:

$$a(d f/dt) + b f = 0$$

where **a** and **b** are constants. We substitute **s** for the differentiation operator **d/dt** in the original differential equation resulting in



$$a(d f/dt) + bf = (as + b) f = 0$$

From this we may directly obtain the characteristic equation:  $as + b = 0$

which has the single root  $s = -b/a$ . Hence the solution to our differential equation is then given by :

$$f = A.e^{-bt/a}$$

This basic procedure can be easily extended to second-order differential equations which we will encounter for **RLC** circuits and we will find it useful since adopting the variable separation method is quite complex for solving second order differential equations.

### RLC CIRCUITS:

Earlier, we studied circuits which contained only **one** energy storage element, combined with a passive network which partly determined how long it took either the capacitor or the inductor to charge/discharge. The differential equations which resulted from analysis were always first-order. In this chapter, we consider more complex circuits which contain **both** an inductor and a capacitor. The result is a **second-order** differential equation for any voltage or current of interest. What we learned earlier is easily extended to the study of these so-called **RLC** circuits, although now we need **two** initial conditions to solve each differential equation. There are two types of RLC circuits: **Parallel RLC circuits** and **Series circuits**. Such circuits occur routinely in a wide variety of applications and are very important and hence we will study both these circuits.

#### Parallel RLC circuit:

Let us first consider the simple parallel RLC circuit with DC excitation as shown in the figure below.

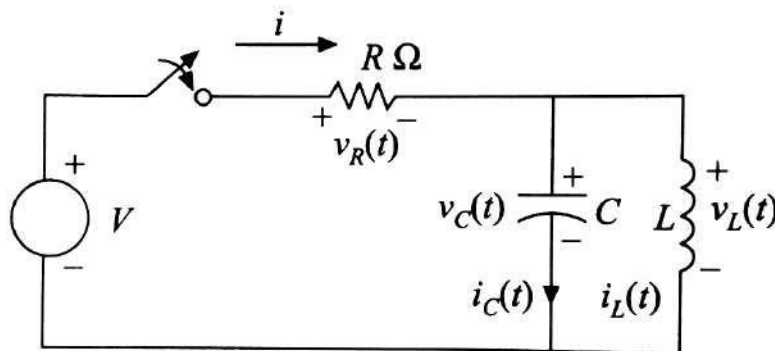


Fig: Parallel RLC circuit with DC excitation.

For the sake of simplifying the process of finding the response we shall also assume that the initial current in the inductor and the voltage across the capacitor are zero. Then applying the Kirchhoff's current law (KCL) ( $i = i_C + i_L$ ) to the common node we get the following integrodifferential equation:

$$(V-v)/R = 1/L \int_{t_0}^t v dt' + C. dv/dt$$

$$V/R = v/R + 1/L \int_{t_0}^t v dt' + C \cdot dv/dt$$

Where  $v = v_c(t) = v_L(t)$  is the variable whose value is to be obtained .

When we differentiate both sides of the above equation once with respect to time we get the standard Linear second-order homogeneous differential equation

$$C \cdot (d^2v/dt^2) + (1/R) \cdot (dv/dt) + (1/L) \cdot v = 0$$

$$(d^2v/dt^2) + (1/RC) \cdot (dv/dt) + (1/LC) \cdot v = 0$$

whose solution  $v(t)$  is the desired response.

This can be written in the form:

$$[s^2 + (1/RC)s + (1/LC)] \cdot v(t) = 0$$

where 's' is an operator equivalent to  $(d/dt)$  and the corresponding *characteristic equation* (as explained earlier as a direct route to obtain the solution) is then given by :

$$[s^2 + (1/RC)s + (1/LC)] = 0$$

This equation is usually called the *auxiliary equation* or the *characteristic equation*, as we discussed earlier .If it can be satisfied, then our assumed solution is correct. This is a quadratic equation and the roots  $s_1$  and  $s_2$  are given as :

$$s_1 = -1/2RC + \sqrt{[(1/2RC)^2 - 1/LC]}$$

$$s_2 = -1/2RC - \sqrt{[(1/2RC)^2 - 1/LC]}$$

And we have the general form of the response as :

$$v(t) = A_1 e^{s_1 t} + A_2 e^{s_2 t}$$

where  $s_1$  and  $s_2$  are given by the above equations and  $A_1$  and  $A_2$  are two arbitrary constants which are to be selected to satisfy the two specified initial conditions.

### Definition of Frequency Terms:

The form of the natural response as given above gives very little insight into the nature of the curve we might obtain if  $v(t)$  were plotted as a function of time. The relative amplitudes of  $A_1$  and  $A_2$ , for example, will certainly be important in determining the shape of the response curve. Further the constants  $s_1$  and  $s_2$  can be real numbers or conjugate complex numbers, depending upon the values of  $R$ ,  $L$ , and  $C$  in the given network. These two cases will produce fundamentally different response forms. Therefore, it will be helpful to make some simplifying substitutions in the equations for  $s_1$  and  $s_2$ . Since the exponents  $s_1 t$  and  $s_2 t$  must be dimensionless,  $s_1$  and  $s_2$  must have the unit of some dimensionless quantity "per second." Hence in the equations for  $s_1$  and  $s_2$  we see that the units of  $1/2RC$  and  $1/LC$  must also be  $s^{-1}$  (i.e., **seconds<sup>-1</sup>**). Units of this type are called *frequencies*.



$$\omega_0 = 1/\sqrt{LC}$$

which is termed as *resonant frequency* and

$$\alpha = 1/2RC$$

which is termed as the *exponential damping coefficient*

$\alpha$  the *exponential damping coefficient* is a measure of how rapidly the natural response decays or damps out to its steady, final value (usually zero). And  $s_1$ ,  $s_2$ ,  $\alpha$ , and  $\omega_0$  are called *complex frequencies*.

We should note that  $s_1$ ,  $s_2$ ,  $\alpha$ , and  $\omega_0$  are merely symbols used to simplify the discussion of *RLC* circuits. They are not mysterious new parameters of any kind. It is easier, for example, to say "*alpha*" than it is to say "*the reciprocal of 2RC*."

Now we can summarize these results.

The response of the parallel *RLC* circuit is given by :

$$v(t) = A_1 e^{s_1 t} + A_2 e^{s_2 t} \dots \dots \dots [1]$$

where

$$s_1 = -\alpha + \sqrt{\alpha^2 - \omega_0^2} \dots \dots \dots [2]$$

$$s_2 = -\alpha - \sqrt{\alpha^2 - \omega_0^2} \dots \dots \dots [3]$$

$$\alpha = 1/2RC \dots \dots \dots [4]$$

and

$$\omega_0 = 1/\sqrt{LC} \dots \dots \dots [5]$$

$A_1$  and  $A_2$  must be found by applying the given initial conditions.

We note three basic scenarios possible with the equations for  $s_1$  and  $s_2$  depending on the relative values of  $\alpha$  and  $\omega_0$  (which are in turn dictated by the values of  $R$ ,  $L$ , and  $C$ ).

**Case A:**

$\alpha > \omega_0$ , i.e. when  $(1/2RC)^2 > 1/LC$ ,  $s_1$  and  $s_2$  will both be negative real numbers, leading to what is referred to as an *over damped response* given by :

$$v(t) = A_1 e^{s_1 t} + A_2 e^{s_2 t}$$

Since  $s_1$  and  $s_2$  are both negative real numbers this is the (algebraic) sum of two decreasing exponential terms. Since  $s_2$  is a larger negative number it decays faster and then the response is dictated by the first term  $A_1 e^{s_1 t}$ .

**Case B :**

$\alpha = \omega_0$ , i.e. when  $(1/2RC)^2 = 1/LC$ ,  $s_1$  and  $s_2$  are equal which leads to what is called a *critically damped response* given by :

$$v(t) = e^{-\alpha t} (A_1 t + A_2)$$

**Case C :**

$\alpha < \omega_0$ , i.e when  $(1/2RC)^2 < 1/LC$  both  $s_1$  and  $s_2$  will have nonzero imaginary components, leading to what is known as an **under damped response** given by :

$$v(t) = e^{-\alpha t}(A_1 \cos \omega_d t + A_2 \sin \omega_d t)$$

where  $\omega_d$  is called **natural resonant frequency** and is given by:

$$\omega_d = \sqrt{\omega_0^2 - \alpha^2}$$

We should also note that the general response given by the above equations [1] through [5] describe not only the voltage but all three branch currents in the parallel RLC circuit; the constants  $A_1$  and  $A_2$  will be different for each, of course.

Transient response of a series RLC circuit:

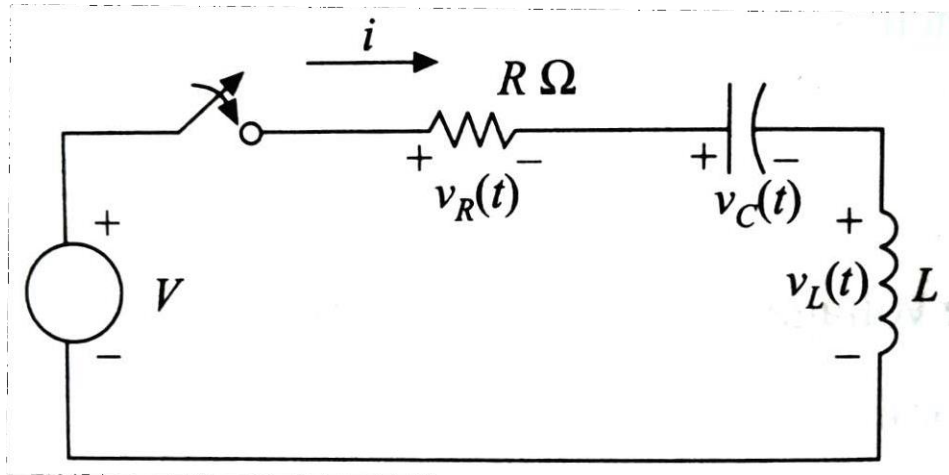


Fig: Series RLC circuit with external DC Excitation

Applying **KVL** to the series **RLC** circuit shown in the figure above at  $t=0$  gives the following basic relation :

$$V = v_R(t) + v_C(t) + v_L(t)$$

Representing the above voltages in terms of the current  $i$  in the circuit we get the following integrodifferential equation:

$$Ri + 1/C \int i dt + L (di/dt) = V$$

To convert it into a differential equation it is differentiated on both sides with respect to time and we get

$$L(d^2i/dt^2) + R(di/dt) + (1/C)i = 0$$

This can be written in the form

$[S^2 + (R/L)s + (1/LC)].i = 0$  where 's' is an operator equivalent to  $(d/dt)$

And the corresponding characteristic equation is then given by

$$[s^2 + (R/L)s + (1/LC)] = 0$$

This is in the standard quadratic equation form and the roots  $s_1$  and  $s_2$  are given by

$$s_1, s_2 = -R/2L \pm \sqrt{[(R/2L)^2 - (1/LC)]} = -\alpha \pm \sqrt{(\alpha^2 - \omega_0^2)}$$

Where  $\alpha$  is known as the same **exponential damping coefficient** and  $\omega_0$  is known as the same **Resonant frequency** as explained in the case of Parallel RLC circuit and are given by :

$$\alpha = R/2L \text{ and } \omega_0 = 1/\sqrt{LC}$$

and  $A_1$  and  $A_2$  must be found by applying the given initial conditions.

Here also we note three basic scenarios with the equations for  $s_1$  and  $s_2$  depending on the relative sizes of  $\alpha$  and  $\omega_0$  (dictated by the values of R, L, and C).

**Case A:**

$\alpha > \omega_0$ , i.e when  $(R/2L)^2 > 1/LC$ ,  $s_1$  and  $s_2$  will both be negative real numbers, leading to what is referred to as an **over damped response** given by :

$$i(t) = A_1 e^{s_1 t} + A_2 e^{s_2 t}$$

Since  $s_1$  and  $s_2$  are both be negative real numbers this is the (algebraic) sum of two decreasing exponential terms. Since  $s_2$  is a larger negative number it decays faster and then the response is dictated by the first term  $A_1 e^{s_1 t}$ .

**Case B :**

$\alpha = \omega_0$ , i.e when  $(R/2L)^2 = 1/LC$ ,  $s_1$  and  $s_2$  are equal which leads to what is called a **critically damped response** given by :

$$i(t) = e^{-\alpha t}(A_1 t + A_2)$$

**Case C :**

$\alpha < \omega_0$ , i.e when  $(R/2L)^2 < 1/LC$  both  $s_1$  and  $s_2$  will have nonzero imaginary components, leading to what is known as an **under damped response** given by :

$$i(t) = e^{-\alpha t}(A_1 \cos \omega_d t + A_2 \sin \omega_d t)$$

where  $\omega_d$  is called **natural resonant frequency** and is given given by:

$$\omega_d = \sqrt{\omega_0^2 - \alpha^2}$$

Here the constants  $A_1$  and  $A_2$  have to be calculated out based on the initial conditions case by case.

**Summary of the Solution Process:**

In summary, then, whenever we wish to determine the transient behavior of a simple three-element RLC circuit, we must first decide whether it is a series or a parallel circuit, so that we may use the correct relationship for  $\alpha$ . The two equations are

$$\alpha = 1/2RC \quad (\text{parallel RLC})$$

$$\alpha = R/2L \quad (\text{series RLC})$$

Our second decision is made after comparing  $\alpha$  with  $\omega_0$ , which is given for either circuit by  $\omega_0 = 1/\sqrt{LC}$

- If  $\alpha > \omega_0$ , the circuit is **over damped**, and the natural response has the form

$$f_n(t) = A_1 e^{s_1 t} + A_2 e^{s_2 t}$$

where

$$s_{1,2} = -\alpha \pm \sqrt{\alpha^2 - \omega_0^2}$$

- If  $\alpha = \omega_0$ , then the circuit is **critically damped** and

$$f_n(t) = e^{-\alpha t}(A_1 t + A_2)$$

- And finally, if  $\alpha < \omega_0$ , then we are faced with the **underdamped** response,

$$f_n(t) = e^{-\alpha t}(A_1 \cos \omega_d t + A_2 \sin \omega_d t)$$

where

$$\omega_d = \sqrt{\omega_0^2 - \alpha^2}$$

**Solution using Laplace transformation method:**

In this topic we will study Laplace transformation method of finding solution for the differential equations that govern the circuit behavior. This method involves three steps:

- First the given Differential equation is converted into “s” domain by taking its Laplace transform and an algebraic expression is obtained for the desired variable
- The transformed equation is split into separate terms by using the method of Partial fraction expansion
- Inverse Laplace transform is taken for all the individual terms using the standard inverse transforms.

The expression we get for the variable in time domain is the required solution.

For the ease of reference a table of important transform pairs we use frequently is given below.

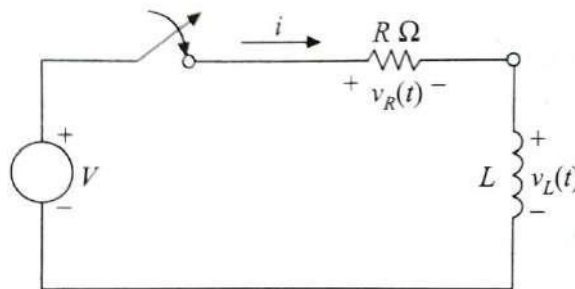
**Table of Important Transform pairs**

$f(t)$ (Function)	$F(s)$ (Laplace Transform)
$u(t)$ (unit step)	$1/s$
$\delta(t)$ (unit impulse)	$1$
$e^{-at}$	$\frac{1}{(s+a)}$
$\sin \omega t$	$\frac{\omega}{(s^2 + \omega^2)}$
$\cos \omega t$	$\frac{s}{(s^2 + \omega^2)}$
$e^{-at} \sin \omega t$	$\frac{\omega}{(s+a)^2 + \omega^2}$
$e^{-at} \cos \omega t$	$\frac{(s+a)}{(s+a)^2 + \omega^2}$
$t$	$1/s^2$
$\frac{df(t)}{dt}$	$sF(s)$
$\int f(t)dt$	$F(s)/s$

This method is relatively simpler compared to Solving the Differential equations especially for higher order differential equations since we need to handle only algebraic equations in 's' domain. This method is illustrated below for the series **RL**, **RC** and **RLC** circuits.

#### Series RL circuit with DC excitation:

Let us take the **series RL** circuit with external DC excitation shown in the figure below.



**Fig: RL Circuit with external DC excitation**

The governing equation is same as what we obtained earlier.

$$V = Ri + Ldi/dt \text{ for } t > 0$$

Taking Laplace transform of the above equation using the standard transform functions we get



$$V/s = R.i(s) + L[si(s) - i(0)]$$

It may be noted here that  $i(0)$  is the initial value of the current at  $t=0$  and since in our case at  $t=0$  just when the switch is closed it is zero, the above equation becomes:

$$V/s = R.i(s) + L[si(s)] = i(s)[R + L.s]$$

$$\text{Or } i(s) = \left[ \frac{\frac{V}{L}}{s\{s+\frac{R}{L}\}} \right] = \frac{A}{s} + \frac{B}{[s+\frac{R}{L}]} \text{ (Expressing in the form of Partial fractions)}$$

$$\text{Where } A = \left[ \frac{\frac{V}{L}}{s+\frac{R}{L}} \right]_{s=0} = V/R \quad \text{and} \quad B = \left[ \frac{\frac{V}{L}}{s} \right]_{s=-\frac{R}{L}} = -V/R$$

Now substituting these values of **A** and **B** in the expression for  $i(s) = \frac{A}{s} + \frac{B}{[s+\frac{R}{L}]}$  we get

$$i(s) = \frac{V/R}{s} - \frac{V/R}{[s+\frac{R}{L}]}$$

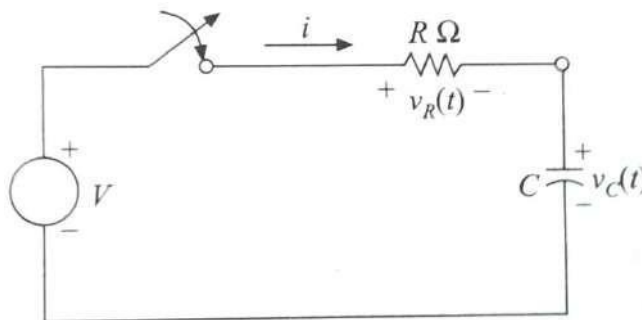
Taking inverse transform of the above expression for  $i(s)$  using the standard transform pairs we get the solution for  $i(t)$  as

$$i(t) = (V/R) - (V/R).e^{-(R/L)t} = (V/R)(1 - e^{-(R/L)t})$$

Which is the same as what we got earlier by solving the governing differential equation directly.

### RC Circuit with external DC excitation:

Let us now take the **series RC** circuit with external DC excitation shown in the figure below.



**Fig: RC Circuit with external DC excitation**

The governing equation is same as what we obtained earlier and is worked out again for easy understanding :

Applying KVL around the loop in the above circuit we can write:

$$V = v_R(t) + v_C(t)$$

Using the standard relationships of voltage and current for an Ideal Capacitor we get

$$v_C(t) = (1/C) \int i(t) dt \text{ or } i(t) = C.[dv_C(t)/dt]$$

(Assuming that the initial voltage across the capacitor  $v_C(0) = 0$ )

and using this relation,  $v_R(t)$  can be written as  $v_R(t) = Ri(t) = R.C.[dv_C(t)/dt]$

Using the above two expressions for  $v_R(t)$  and  $v_C(t)$  the above expression for  $V$  can be rewritten as :

$$V = R.C.[dv_C(t)/dt] + v_C(t)$$

Now we will take Laplace transform of the above equation using the standard Transform pairs and rules:

$$V/s = R.C.s.v_C(s) + v_C(s)$$

$$V/s = v_C(s) ( R.C.s + 1 )$$

$$v_C(s) = (V/s) / ( R.C.s + 1 )$$

$$v_C(s) = (V/RC) / [s. (s + 1/RC)]$$

Now expanding this equation into partial fractions we get

$$v_C(s) = (V/RC) / [s. (s + 1/RC)] = A/s + B/(s + 1/RC) \text{ -----(1)}$$

Where  $A = (V/RC) / ( 1/RC ) = V$  and  $B = (V/RC) / - ( 1/RC ) = -V$

Substituting these values of  $A$  and  $B$  into the above equation (1) for  $v_C(s)$  we get

$$v_C(s) = (V/s) - [V / (s + 1/RC)] = V [(1/s) - 1 / (s + 1/RC)]$$

And now taking the inverse Laplace transform of the above equation we get

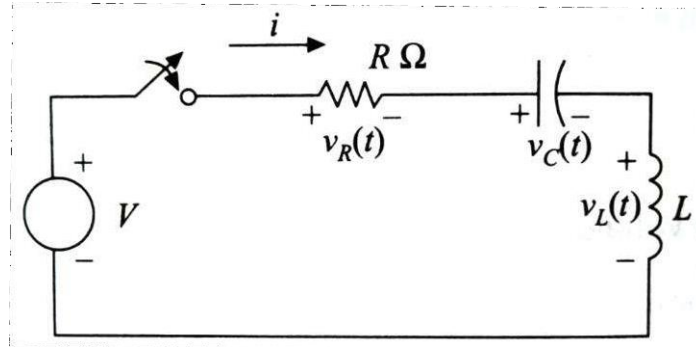
$$v_C(t) = V(1 - e^{-t/RC})$$

which is the voltage across the capacitor as a function of time and is the same as what we obtained earlier by directly solving the differential equation.

And the voltage across the Resistor is given by  $v_R(t) = V - v_C(t) = V - V(1 - e^{-t/RC}) = V.e^{-t/RC}$

And the current through the circuit is given by  $i(t) = C.[dv_c(t)/dt] = (CV/RC) e^{-t/RC} = (V/R) e^{-t/RC}$

**Series RLC circuit with DC excitation:**



**Fig: Series RLC circuit with DC excitation**

The current through the circuit in the Laplace domain is given by :

$$I(s) = \frac{(V/s)}{(R + Ls + 1/Cs)}$$

[since  $\mathcal{L}[V] = V/s$  and the Laplace equivalent of the series circuit is given by  $Z(s) = (R + Ls + 1/Cs)$  ]

$$= V / (Rs + Ls^2 + 1/C) = (V/L) / [s^2 + (R/L)s + 1/LC] = \frac{(V/L)}{(s+a)(s+b)}$$

Where the roots 'a' and 'b' are given by

$$a = -R/2L + \sqrt{(R/2L)^2 - 1/LC} \text{ and}$$

$$b = -R/2L - \sqrt{(R/2L)^2 - 1/LC}$$

It may be noted that there are three possible solutions for for  $I(s)$  and we will consider them.

**Case A:** Both a and b are real and not equal i.e.  $(R/2L) > 1/\sqrt{LC}$

Then  $I(s)$  can be expressed as 
$$I(s) = \frac{(V/L)}{(s+a)(s+b)} = \frac{K1}{(s+a)} + \frac{K2}{(s+b)}$$

Where  $K1 = \left[ \frac{(V/L)}{(s+b)} \right]_{s=-a} = \frac{(V/L)}{(b-a)}$

Where  $K_2 = \left[ \frac{(V/L)}{(s+a)} \right] s = -b = \frac{(V/L)}{(a-b)}$

Substituting these values of  $K_1$  and  $K_2$  in the expression for  $I(s)$  we get :

$$I(s) = \frac{(V/L)}{(s+a)(s+b)} = \frac{(V/L)}{(b-a)} \frac{1}{(s+a)} + \frac{(V/L)}{(a-b)} \frac{1}{(s+b)}$$

$$i(t) = \frac{(V/L)}{(b-a)} e^{-at} + \frac{(V/L)}{(a-b)} e^{-bt}$$

**Case B :** Both  $a$  and  $b$  are real and equal i.e. ( $a=b=c$ ) i.e.  $(R/2L) = 1/\sqrt{LC}$

$$I(s) = (V/L)/(s+c)^2 \text{ when } a = b = c \quad \text{and}$$

$$i(t) = (V/L) \cdot t \cdot e^{-ct}$$

**Case C :** Both  $a$  and  $b$  are complex conjugates i.e.  $a = b^*$  when  $(R/2L) < 1/\sqrt{LC}$

Adopting our standard definitions of  $\alpha = R/2L$   $\omega_0 = 1/\sqrt{LC}$  and  $\omega_d = \sqrt{(\omega_0^2 - \alpha^2)}$

The roots  $a$  and  $b$  are given by  $a = \alpha + j\omega_d$  and  $b = \alpha - j\omega_d$

Then  $I(s)$  can be expressed as  $I(s) = \frac{(V/L)}{(s+a-j\omega_d)(s+a+j\omega_d)} = \frac{K_3}{(s+a-j\omega_d)} + \frac{K_3^*}{(s+a+j\omega_d)}$

Here  $K_3 = (s+a-j\omega_d) \cdot I(s) |_{s=-a+j\omega_d} = \frac{(V/L)}{(s+a+j\omega_d)} |_{s=-a+j\omega_d} = \frac{(V/L)}{2j\omega_d}$

Therefore:  $K_3 = \frac{(V/L)}{2j\omega_d}$  and  $K_3^* = -\frac{(V/L)}{2j\omega_d}$

Now substituting these values  $K_3$  and  $K_3^*$  in the above expanded equation for  $I(s)$  we get

$$I(s) = \frac{(V/L)}{2j\omega_d} \frac{1}{(s+a-j\omega_d)} - \frac{(V/L)}{2j\omega_d} \frac{1}{(s+a+j\omega_d)}$$

And now taking inverse transform of  $I(s)$  we get

$$i(t) = \frac{(V/L)}{2j\omega_d} e^{-\alpha t} \cdot e^{j\omega_d t} - \frac{(V/L)}{2j\omega_d} e^{-\alpha t} \cdot e^{-j\omega_d t}$$

$$i(t) = \frac{(V/L)}{\omega_d} e^{-\alpha t} [(e^{j\omega_d t} - e^{-j\omega_d t})/2j]$$

$$i(t) = \frac{(V/L)}{\omega d} e^{-\alpha t} \sin \omega_d t$$

### Summary of important formulae and equations:

#### RL circuit with external DC excitation ( Charging Transient ) :

- $i(t) = V/R [1 - e^{-t/\tau}]$
- $v_L(t) = V (e^{-t/\tau})$
- $v_R(t) = i(t).R = V [1 - e^{-t/\tau}]$

#### Source free RL circuit ( Decay Transients ) :

- $i(t) = (V/R) \cdot e^{-t/\tau}$  ;  $v_R(t) = R.i(t) = Ve^{-t/\tau}$  and  $v_L(t) = -Ve^{-t/\tau}$

#### RC circuit with external DC excitation ( Discharge Transients ):

- $v_C(t) = V(1 - e^{-t/RC})$
- $v_R(t) = V \cdot e^{-t/RC}$
- $i(t) = (V/R) e^{-t/RC}$

#### Source free RC circuit ( Discharge transients ) :

- $v_C(t) = Ve^{-t/\tau}$  ;  $v_R(t) = -Ve^{-t/\tau}$  and  $i(t) = v_R(t)/R = (-V/R)e^{-t/\tau}$

#### Series RLC circuit: For this circuit three solutions are possible :

1.  $\alpha > \omega_0$ , i.e when  $(R/2L)^2 > 1/LC$ ,  $s_1$  and  $s_2$  will both be negative real numbers, leading to what is referred to as an **over damped response** given by :

$$i(t) = A_1 e^{s_1 t} + A_2 e^{s_2 t}$$

2.  $\alpha = \omega_0$ , i.e when  $(R/2L)^2 = 1/LC$   $s_1$  and  $s_2$  are equal which leads to what is called a **critically damped response** given by :

$$i(t) = e^{-\alpha t}(A_1 t + A_2)$$

3.  $\alpha < \omega_0$ , i.e when  $(R/2L)^2 < 1/LC$  both  $s_1$  and  $s_2$  will have nonzero imaginary components, leading to what is known as an **under damped response** given by :

$$i(t) = e^{-\alpha t}(A_1 \cos \omega_d t + A_2 \sin \omega_d t)$$

where :

- $\alpha = (R/2L)$  and is called the exponential damping coefficient
- $\omega_0 = 1/\sqrt{LC}$  and is called the resonant frequency
- $\omega_d = \sqrt{\omega_0^2 - \alpha^2}$  and is called the *natural resonant frequency*

### Illustrative Examples:

**Example 1:** Find the current in a series RL circuit having  $R = 2\Omega$  and  $L = 10H$  when a DC voltage  $V$  of 100V is applied. Find the value of the current 5 secs. after the application of the DC voltage.

**Solution:** This is a straightforward problem which can be solved by applying the formula. First let us find out the *Time constant*  $\tau$  of the series LR circuit which is given by  $\tau = L/R$  secs.

$$\therefore \tau = 10/2 = 5 \text{ secs}$$

The current in a series LR circuit after the sudden application of a DC voltage is given by :

$$i(t) = V/R (1 - e^{-t/\tau})$$

$$\therefore i(t) \text{ at } 5 \text{ secs} = 100/2 (1 - e^{-5/5}) = 50 (1 - e^{-1}) = 50 (1 - 1/e) = 31.48$$

$$\therefore i(t) \text{ at } 5 \text{ secs} = 31.48 \text{ Amps}$$

**Example 2:** A series RL circuit has  $R = 25 \Omega$  and  $L = 5$  Henry. A dc voltage  $V$  of 100 V is applied to this circuit at  $t = 0$  secs. Find :

- The equations for the charging current, and voltage across R & L
- The current in the circuit 0.5 secs after the voltage is applied.
- The time at which the drops across R and L are equal.

**Solution:** The solutions for (a) and (b) are straightforward as in the earlier problem.

(a) *Time constant*  $\tau$  of the series LR circuit which is given by  $\tau = L/R$  secs

$$\therefore \tau = 5/25 = 1/5 \text{ secs}$$

- The charging current is given by  $i(t) = V/R (1 - e^{-t/\tau})$

**It is also given by  $i(t) = I (1 - e^{-t/\tau})$  where  $I$  is the final steady state current and is equal to  $V/R$**

$$= 100/25 (1 - e^{-t/(1/5)}) = 4 (1 - e^{-5t}) \text{ Amps}$$

$$i(t) = 4 (1 - e^{-5t}) \text{ Amps}$$

- The voltage across R is given by  $v_R = i(t) \cdot R = V/R (1 - e^{-t/\tau}) \cdot R = V (1 - e^{-t/\tau})$

$$v_R = 100 (1 - e^{-5t})$$

- The voltage drop across L can be found in two ways.
  1. Voltage across Inductor  $v_L = L di/dt$

2. Voltage across Inductor  $v_L = V - v_R$

But it is easier to find using the second method.  $\therefore v_L = 100 - 100(1 - e^{-5t})$

$$v_L = 100 \cdot e^{-5t}$$

(b) At time  $t = 0.5$  sec  $i(t) = 4(1 - e^{-5t}) = 4(1 - e^{-2.5}) = 3.67$  Amps

(c) To find out the time at which the voltages across the Inductor and the Resistor are equal we can equate the expressions for  $v_R = 100(1 - e^{-5t})$  and  $v_L = 100 \cdot e^{-5t}$  and solve for  $t$ . But the simpler method is, we know that since the applied voltage is 100 V the condition  $v_R = v_L$  will also be satisfied when  $v_R = v_L = 50$  V. i.e.  $v_R = 100(1 - e^{-5t}) = 50$  volts and  $v_L = 100 \cdot e^{-5t} = 50$  V. We will solve the second equation  $[v_L = 100 \cdot e^{-5t} = 50 \text{ V}]$  to get  $t$  which is easier.

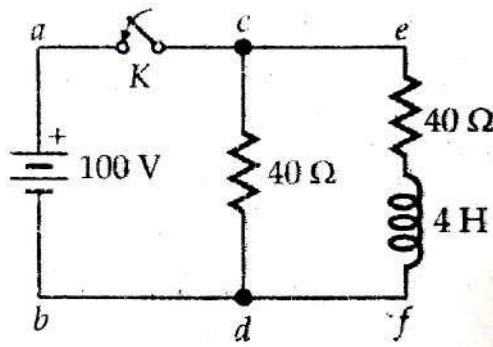
$$e^{-5t} = 50/100 = 0.5$$

Taking natural logarithm on both sides we get:

$$-5t \cdot \ln(e) = \ln 0.5 \quad \text{i.e.} \quad -5t \cdot 1 = -0.693 \quad \text{i.e.} \quad t = 0.693/5 = 0.139 \text{ secs}$$

$\therefore$  **The voltages across the resistance and the Inductance are equal at time  $t = 0.139$  secs**

**Example 3:** In the figure shown below after the steady state condition is reached, at time  $t = 0$  the switch K is suddenly opened. Find the value of the current through the inductor at time  $t = 0.5$  seconds.



**Solution:** The current in the path **acdb** ( through the resistance of  $40 \Omega$  alone) is  $100/40 = 2.5$  Amps. ( Both steady state and transient are same )

The steady state current through the path **ae fb** (through the resistance of  $40 \Omega$  and inductance of  $4H$ ) is also  $= 100/40 = 2.5$  Amps.

Now when the switch K is suddenly opened, the current through the path **acdb**( through the resistance of  $40 \Omega$  alone) immediately becomes zero because this path contains only resistance. But the current through the inductor decays gradually but now through the different path **efdc** The decay current through a closed RL circuit is given by  $I \cdot e^{-t/\tau}$  where  $I$  is the earlier steady state current of  $2.5$  amps through  $L$  and  $\tau = L/R$  of the decay circuit. **It is to be noted carefully here that in the decay path both resistors are there and hence  $R = 40 + 40 = 80 \Omega$**

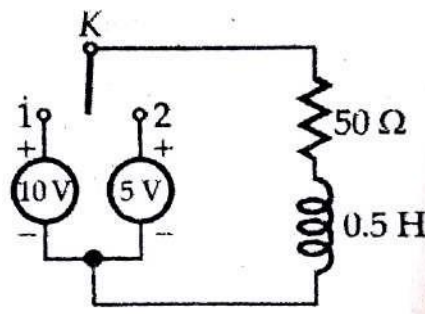
Hence  $\tau = L/R = 4/80 = 0.05$  secs

Hence the current through the inductor at time 0.5 secs is given by  $i(t) @_{0.5\text{secs}} = 2.5.e^{-0.5/0.05}$   
 i.e  $i(t) @_{0.5\text{secs}} = 2.5.e^{-10}$

**i.e  $i(t) @_{0.5\text{secs}} = 1.14 \times 10^{-4}$  Amps**

**Example 4:** In the circuit shown below the switch is closed to position 1 at time  $t = 0$  secs. Then at time  $t = 0.5$  secs the switch is moved to position 2. Find the expressions for the current through the circuit from 0 to 0.5 msecs and beyond 0.5 msecs.

**Solution:** The time constant  $\tau$  of the circuit in both the conditions is same and is given by  $\tau = L/R = 0.5/50 = 0.01$  secs



1. During the time  $t=0$  to 0.5 msecs.  $i(t)$  is given by the standard expression for growing current through a L R circuit:  $i(t)_{\text{during } 0 \text{ to } 0.5 \text{ msecs}} = V/R ( 1 - e^{-t/\tau} )$

**$i(t)_{\text{during } 0 \text{ to } 0.5 \text{ msecs}} = V/R ( 1 - e^{-t/0.01} )$  Amps**

And the current  $i(t) @_{t=0.5 \text{ msecs}} = 10/50 ( 1 - e^{-0.5 \times 10^{-3} / 0.01} ) = 0.2 ( 1 - e^{-0.05} ) = 9.75$  mA

**$i(t) @_{t=0.5 \text{ msecs}} = 9.75$  mA and this would be the initial current when the switch is moved to position 2**

2. During the time beyond 0.5 msecs ( switch is in position 2): The initial current is 9.75 mA . The standard expression for the growing current  $i(t) = V/R ( 1 - e^{-t/\tau} )$  is not applicable now since it has been derived with initial condition of  $i(t) = 0$  at  $t=0$  where as the initial condition for the current  $i(t)$  now in position 2 is **9.75 mA** . Now an expression for  $i(t)$  in position 2 is to be derived from first principles taking fresh  $t=0$  and initial current  $i(0)$  as 9.75mA.

The governing equation in position 2 is given by :

**$50i + 0.5di/dt = 5$**

We will use the same *separation of variables method* to solve this differential equation. Dividing the above equation by **0.5**, then multiplying by **dt** and separating the terms containing the two variables **i** and **t** we get:

$100i + di/dt = 10$  i.e  $100i \cdot dt + di = 10 \cdot dt$  i.e  $di = dt ( 10 - 100i )$  i.e  $di / ( 10 - 100i ) = dt$

Now integrating on both sides we get

$-1/100 \ln ( 10 - 100i ) = t + K$ ----- (1)



The constant K is now to be evaluated by invoking the new initial condition  $i(t) = 9.75 \text{ mA}$  at  $t = 0$

$$-1/100 \ln ( 10 - 100 \times 9.75 \times 10^{-3} ) = K = -1/100 \ln ( 10 - 0.975 ) = -1/100 \ln ( 9.025 )$$

Substituting this value of K in the above equation (1) we get

$$-1/100 \ln ( 10 - 100i ) = t - 1/100 \ln ( 9.025 )$$

$$-1/100 \ln ( 10 - 100i ) + 1/100 \ln ( 9.025 ) = t$$

$$-1/100 [ \ln ( 10 - 100i ) - \ln ( 9.025 ) ] = t$$

$$-1/100 \cdot \ln [ ( 10 - 100i ) / ( 9.025 ) ] = t$$

$$\ln [ ( 10 - 100i ) / ( 9.025 ) ] = -100t$$

Taking antilogarithm to base  $e$  on both sides we get:

$$( 10 - 100i ) / ( 9.025 ) = e^{-100t}$$

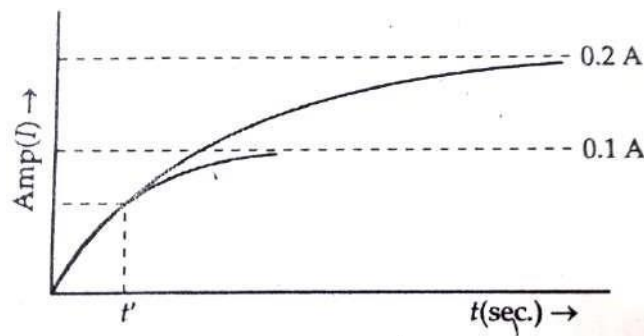
$$( 10 - 100i ) = 9.025 \times e^{-100t}$$

$$( 10 - 9.025 \times e^{-100t} ) = 100i$$

$$i = ( 10 - 9.025 \times e^{-100t} ) / 100 = 10/100 - 9.025 \times e^{-100t} / 100$$

$$\text{And finally } i = 0.1 - 0.09 \cdot e^{-100t}$$

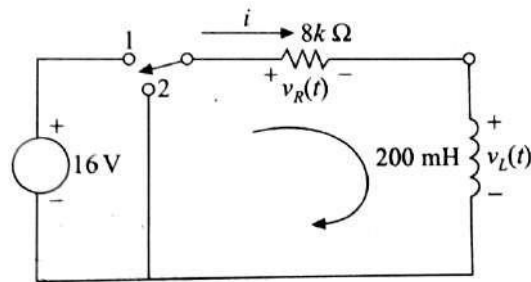
The currents during the periods  $t = 0$  to  $0.5 \text{ msec}$  and beyond  $t = 0.5 \text{ msec}$  are shown in the figure below. Had the switch been in position 1 all through, the current would have reached the steady state value of  $0.2 \text{ amps}$  corresponding to source voltage of  $10 \text{ volts}$  as shown in the top curve. But since the switch is changed to position 2 the current changed its path towards the new steady state current of  $0.1 \text{ Amps}$  corresponding to the new source voltage of  $5 \text{ Volts}$  from  $0.5 \text{ msec}$  onwards.



**Example 5:** In the circuit shown below the switch is kept in position 1 upto  $250 \mu\text{secs}$  and then moved to position 2. Find

- The current and voltage across the resistor at  $t = 100 \mu\text{secs}$
- The current and voltage across the resistor at  $t = 350 \mu\text{secs}$

**Solution :** The time constant  $\tau$  of the circuit is given by  $\tau = L/R = 200\text{mH}/8\text{K}\Omega = 25 \mu\text{sec}$  and is same in both the switch positions.



(a) The current in the circuit upto  $250 \mu\text{sec}$  ( till switch is in position 1 ) is given by :  
 $i(t)_{\text{growing}} = V/R (1 - e^{-t/\tau}) = (16/8) \times 10^{-3} (1 - e^{-t/25 \times 10^{-6}}) = 2 \times (1 - e^{-t/25 \times 10^{-6}}) \text{ mA}$

- The current in the circuit @  $100 \mu\text{sec}$  is given by  
 $i(t)_{@100 \mu\text{sec}} = 2 \times (1 - e^{-100 \mu\text{sec}/25 \mu\text{sec}}) \text{ mA} = 2 \times (1 - e^{-4}) \text{ mA} = 1.9633 \text{ mA}$

$$i(t)_{@100 \mu\text{sec}} = 1.9633 \text{ m}$$

- The Voltage across the resistor is given by  $v_{R@100 \mu\text{sec}} = R \times i(t)_{@100 \mu\text{sec}}$   
 $v_{R@100 \mu\text{sec}} = 8 \text{ K}\Omega \times 1.9633 \text{ mA} = 15.707 \text{ V}$

$$v_{R@100 \mu\text{sec}} = 15.707 \text{ V}$$

(b)(b)

- The current in the circuit @  $350 \mu\text{sec}$  is the decaying current and is given by:

$i(t)_{\text{Decaying}} = I(0) \cdot e^{-t/\tau}$  where  $I(0)$  is the initial current and in this case it is the growing current @  $250 \mu\text{sec}$ . ( Since the switch is changed @  $250 \mu\text{sec}$  ) The time  $t$  is to be reckoned from this time of  $250 \mu\text{sec}$ . Hence  $t = (350 - 250) = 100 \mu\text{sec}$ . So we have to calculate first  $i(t)_{\text{growing}@250 \mu\text{sec}}$  which is given by:

$$i(t)_{\text{growing}@250 \mu\text{sec}} = V/R (1 - e^{-t/\tau}) = (16/8) \times 10^{-3} (1 - e^{-250/25 \mu\text{sec}}) = 2 \times (1 - e^{-10}) \text{ mA} = 1.999 \text{ mA}$$

$$i(t)_{\text{growing}@250 \mu\text{sec}} = 1.999 \text{ mA} = I(0)$$

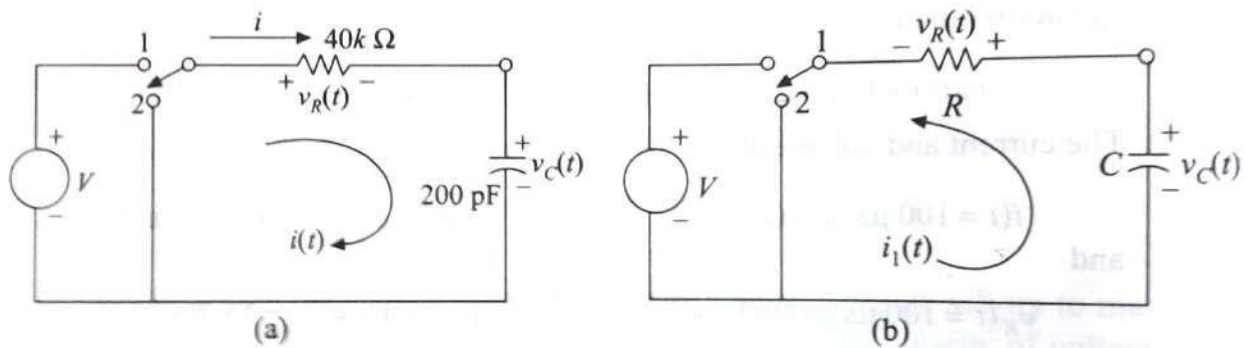
$$\text{Hence } i(t)_{@350 \mu\text{sec}} = I(0) \cdot e^{-t/\tau} = 1.99 \times e^{-100 \mu\text{sec}/25 \mu\text{sec}} \text{ mA} = 1.99 \times e^{-4} \text{ mA} = 0.03663 \text{ mA}$$

$$i(t)_{@350 \mu\text{sec}} = 0.03663 \text{ mA}$$

- The voltage across the resistor  $v_R @ 350 \mu\text{sec} = R \times i(t)_{@350 \mu\text{sec}} = 8 \text{ K}\Omega \times 0.03663 \text{ mA}$   
 $v_R @ 350 \mu\text{sec} = 0.293 \text{ V}$

**Example 6:** In the circuit shown below the switch is kept in position 1 up to 100  $\mu$  secs and then it is moved to position 2 . Supply voltage is 5V DC . Find

- The current and voltage across the capacitor at  $t = 40 \mu$  secs
- The current and voltage across the resistor at  $t = 150 \mu$  secs



**Solution:** The time constant  $\tau$  of the circuit is same in both conditions and is given by  $\tau = RC = 40 \times 10^3 \times 200 \times 10^{-12} = 8 \mu$ sec

- The time  $t = 40 \mu$ sec corresponds to the switch in position 1 and in that condition the current  $i(t)$  is given by the standard expression for charging current

$$i(t) = (V/R) [e^{-t/\tau}]$$

$$i(t)_{@40 \mu\text{sec}} = 5\text{V}/40\text{K}\Omega [e^{-40/8}] \text{ Amps} = 0.125 \times [e^{-5}] \text{ mA} = 0.84224 \mu\text{A}$$

$$i(t)_{@40 \mu\text{sec}} = \mathbf{0.84224 \mu\text{A}}$$

The voltage across the capacitor during the charging period is given by  $V [1 - e^{-t/\tau}]$ .

$$v_C(t)_{@40 \mu\text{sec}} = 5[1 - e^{-40/8}] = 5[1 - e^{-5}] = 4.9663 \text{ Volts}$$

$$v_C(t)_{@40 \mu\text{sec}} = \mathbf{4.9663 \text{ Volts}}$$

- The time  $t = 150 \mu$ sec corresponds to the switch in position 2 and the current  $i(t)$  is given by the discharge voltage expression  $i(t) = [v_C(t)_0/R] \cdot e^{-t/\tau}$

Where  $v_c(t)_0$  is the initial capacitor voltage when the switch was changed to position 2 and it is the voltage that has built up by  $100 \mu\text{sec}$  during the charging time (switch in position 1 ) and hence is given by

$$v_c(t)_{@100\mu\text{sec}} = 5[1 - e^{-100/8}] \text{ volts} = 5x[1 - e^{-12.5}] \text{ Volts} = 4.999 \text{ Volts}$$

And now  $t=150 \mu\text{sec}$  from beginning is equal to  $t = (150-100) = 50 \mu\text{sec}$  from the time switch is changed to position 2.

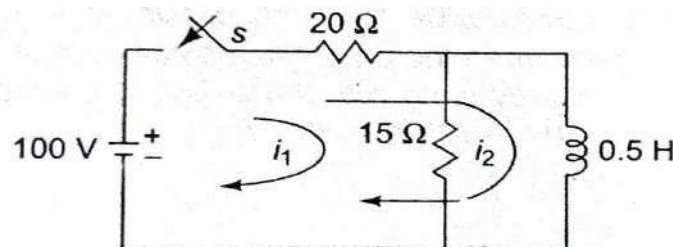
Therefore the current through the resistor at  $150 \mu\text{sec}$  from the beginning =  $i(t)_{150\mu\text{sec}} = (4.999/40\text{K}\Omega) \cdot e^{-t/\tau}$

$$i(t)_{150\mu\text{sec}} = 0.1249 \times e^{-50/8} = 0.241 \mu\text{A}$$

$$i(t)_{150\mu\text{sec}} = 0.241 \mu\text{A}$$

**And the voltage across the resistor =  $R \times i(t) = 40\text{K}\Omega \times 0.241 \mu\text{A} = 0.00964\text{v}$**

**Example 7:** In the circuit shown below find out the expressions for the current  $i_1$  and  $i_2$  when the switch is closed at time  $t=0$



**Solution:** It is to be noted that in this circuit there are two current loops 1 and 2 . Current  $i_1$  alone flows through the resistor  $15 \Omega$  and the current  $i_2$  alone flows through the inductance  $0.5 \text{ H}$  where as both currents  $i_1$  and  $i_2$  flow through the resistor  $20 \Omega$ . Applying KVL to the two loops taking care of this point we get

$$20(i_1 + i_2) + 15 i_1 = 100 \quad \text{i.e} \quad 35 i_1 + 20 i_2 = 100 \text{----- (1)}$$

$$\text{and} \quad 20(i_1 + i_2) + 0.5 \frac{di_2}{dt} = 100 ; \quad 20 i_1 + 20 i_2 + 0.5 \frac{di_2}{dt} = 100 \text{----- (2)}$$

Substituting the value of  $i_1 = [100/35 - (20/35) i_2] = 2.86 - 0.57 i_2$  obtained from the above equation (1) into equation (2) we get :

$$20 [2.86 - 0.57 i_2] + 20i_2 + 0.5 (di_2/dt) = 100$$

$$57.14 - 11.4 i_2 + 20i_2 + 0.5 (di_2/dt) = 100$$

$$(di_2/dt) i_2 + 17.14 i_2 = 85.72$$

The solution for this equation is given by  $i_2(t) = K \cdot e^{-17.14t} + 85.72/17.14$  and the constant  $K$  can be evaluated by invoking the initial condition. The initial current through the inductor = 0 at time  $t = 0$ .

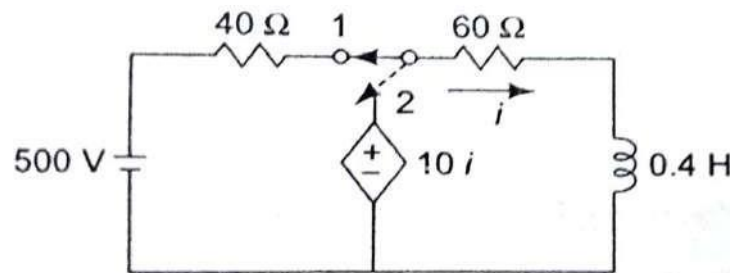
Hence  $K = -85.72/17.14 = -5$

Therefore  $i_2(t) = 5 ( 1 - e^{-17.14t} )$  Amps

And current  $i_1(t) = 2.86 - 0.57 i_2 = 2.86 - 0.57 [ 5 ( 1 - e^{-17.14t} ) ] = 0.01 + 2.85 e^{-17.14t}$  Amps

And current  $i_1(t) = 0.01 + 2.85 e^{-17.14t}$  Amps

**Example 8 :** In the circuit shown below find an expression for the current  $i(t)$  when the switch is changed from position 1 to 2 at time  $t = 0$ .



Solution: The following points are to be noted with reference to this circuit:

- When the switch is changed to position 2 the circuit is equivalent to a normal source free circuit but with a current dependent voltage source given as  $10i$ .
- The initial current in position 2 is same as the current when the switch was in position 1 ( for a long time ) and is given by  $I_0 = 500/(40+60) = 5$  Amps

The loop equation in position 2 is given by :  $60i + 0.4 \frac{di}{dt} = 10i$  i.e  $( 50/0.4 )i + \frac{di}{dt} = 0$

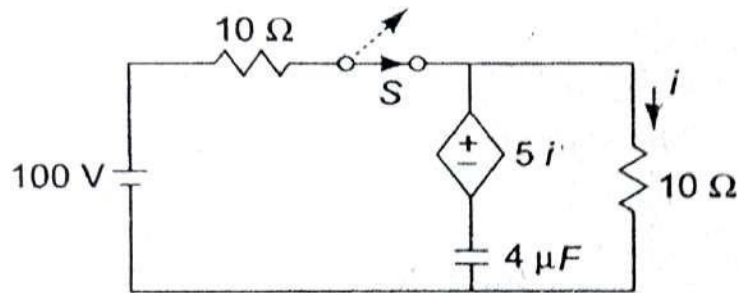
Writing the equation in the 's' notation where 's' is the operator equivalent to  $(d/dt)$  we get

$(s + 125) i = 0$  and the characteristic equation will be  $(s + 125) = 0$

Hence the solution  $i(t)$  is given by  $i(t) = K \cdot e^{-125t}$ . The constant  $K$  can be evaluated by invoking the initial condition that  $i(t) @ t=0$  is equal to  $I_0 = 5$  amps .Then the above equation becomes:

$5 = K \cdot e^{-125 \times 0}$  i.e  $K = 5$  and hence the current in the circuit when the switch is changed to position 2 becomes:  $i(t) = 5 \cdot e^{-125t}$  Amps

**Example 9 :** In the circuit shown below find an expression for the current  $i(t)$  when the switch is opened at time  $t=0$



Solution: The following points may be noted with reference to this circuit:

- When the switch is opened the circuit is equivalent to a normal source free circuit but with a current dependent voltage source given as  $5i$ .
- The initial current  $i_0$  when the switch is opened is same as the current when the switch was closed for a long time and is given by  $i_0 = 100/(10+10) = 5$  Amps

The loop equation when the switch is opened is given by :

$$\begin{aligned} (1/4 \times 10^{-6}) \int i dt + 10i &= 5i \\ (1/4 \times 10^{-6}) \int i dt + 5i &= 0 \end{aligned}$$

Differentiating the above equation we get :

$$5 \cdot (di/dt) + (1/4 \times 10^{-6})i = 0 \quad \text{i.e.} = (di/dt) + (1/20 \times 10^{-6})i = 0$$

Writing the above equation in the 's' notation where 's' is the operator equivalent to  $(d/dt)$  we get

$$(s + 1/20 \times 10^{-6}) i = 0 \text{ and the characteristic equation will be } (s + 1/20 \times 10^{-6}) = 0$$

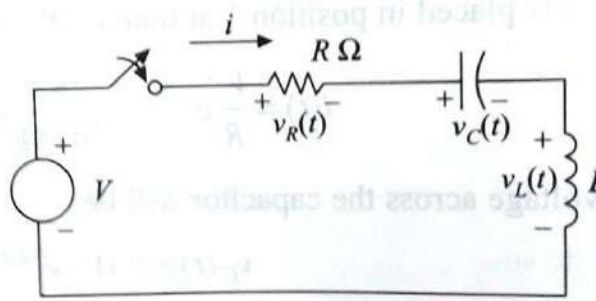
The solution  $i(t)$  is given by  $i(t) = K \cdot e^{-t/20 \times 10^{-6}}$ . The constant  $K$  can be evaluated by invoking the initial condition that  $i(t)_{@t=0}$  is equal to  $i_0 = 5$  amps. Then the above equation becomes:

$$5 = K \cdot e^{-t/20 \times 10^{-6}} \quad \text{i.e. } K = 5 \text{ and hence the current in the circuit when the switch is opened becomes: } \mathbf{i(t) = 5 \cdot e^{-t/20 \times 10^{-6}} \text{ Amps}}$$

**Example 10:** A series RLC circuit as shown in the figure below has  $R = 5\Omega, L = 2H$  and  $C = 0.5F$ . The supply voltage is 10 V DC. Find

- The current in the circuit when there is no initial charge on the capacitor.
- The current in the circuit when the capacitor has initial voltage of 5V
- Repeat question (a) when the resistance is changed to  $4\Omega$

d) Repeat question (a) when the resistance is changed to  $1 \Omega$



**Solution:** The basic governing equation of this series circuit is given by :

$$Ri + \frac{1}{C} \int i dt + L \frac{di}{dt} = V$$

On differentiation we get the same equation in the standard differential equation form

$$L(d^2i/dt^2) + R(di/dt) + (1/C)i = 0$$

By dividing the equation by L and using the operator 's' for d/dt we get the equation in the form of characteristic equation as :

$$[s^2 + (R/L)s + (1/LC)] = 0$$

Whose roots are given by:

$$s_{1,2} = -R/2L \pm \sqrt{[(R/2L)^2 - (1/LC)]} = -\alpha \pm \sqrt{(\alpha^2 - \omega_0^2)}$$

and three types of solutions are possible.

1.  $\alpha > \omega_0$ , i.e when  $LC > (2L/R)^2$   $s_1$  and  $s_2$  will both be negative real numbers, leading to what is referred to as an **over damped response** given by :

$$i(t) = A_1 e^{s_1 t} + A_2 e^{s_2 t}$$

2.  $\alpha = \omega_0$ , i.e when  $LC = (2L/R)^2$   $s_1$  and  $s_2$  are equal which leads to what is called a **critically damped response** given by :

$$i(t) = e^{-\alpha t} (A_1 t + A_2)$$

3.  $\alpha < \omega_0$ , i.e when  $LC < (2L/R)^2$  both  $s_1$  and  $s_2$  will have nonzero imaginary components, leading to what is known as an **under damped response** given by :

$$i(t) = e^{-\alpha t} (A_1 \cos \omega_d t + A_2 \sin \omega_d t)$$

where  $\omega_d$  is called **natural resonant frequency** and is given given by:

$$\omega_d = \sqrt{\omega_0^2 - \alpha^2}$$

The procedure to evaluate the complete solution consists of the following steps for each part of the question:

1. We have to first calculate the roots for each part of the question and depending on to which case the roots belong we have to take the appropriate solution .
2. Then by invoking the first initial condition i.e  $i = 0$  at  $t=0$  obtain the first relation between  $A_1$  and  $A_2$  or one of its values.
3. If one constant value is obtained directly substitute it into the above solution and take its first derivative. Or else directly take the first derivative of the above solution

4. Now obtain the value  $di/dt$  @  $t=0$  from the basic RLC circuit equation by invoking the initial conditions of  $v_C$  @  $t=0$  and  $i(t)$  @  $t=0$ . Now equate this to the differential of the solution for  $i(t)$  to get the second relation between  $A_1$  and  $A_2$  ( or the second constant . Now using these two equations we can solve for  $A_1$  and  $A_2$  and substitute in the solution for  $i(t)$  to get the final solution.

$$(a) s_1, s_2 = -R/2L \pm \sqrt{[(R/2L)^2 - (1/LC)]} = (-5/2 \times 2) \pm \sqrt{[(5/2 \times 2)^2 - (1/2 \times 0.5)]} = -1.25 \pm 0.75.$$

i.e.  $s_1 = -0.5$  and  $s_2 = -2$

In this case the roots are negative real numbers and the solution is given by :

$$i(t) = A_1 e^{s_1 t} + A_2 e^{s_2 t} = A_1 e^{-0.5t} + A_2 e^{-2t} \text{ ----- (1)}$$

Now we will apply the first initial condition i.e  $i(t) = 0$  at  $t=0$ . Then we get

$$0 = A_1 e^{-0.5 \times 0} + A_2 e^{-2 \times 0} \quad \text{i.e.} \quad A_1 + A_2 = 0$$

The basic equation for voltage in the series RLC circuit is given as :

$$V = R.i(t) + v_C(t) + L.(di/dt) \quad \text{i.e} \quad di/dt = 1/L [ V - R.i(t) - v_C(t) ]$$

At time  $t=0$  we get

$$(di/dt)_{@ t=0} = 1/L [ V - R.i(t=0) - v_C(t=0) ] \text{ -----(2)}$$

But we know that the voltage across the capacitor and current are zero at time  $t=0$ .

$$\text{Therefore} \quad (di/dt)_{@ t=0} = V/L = 10/2 = 5 \text{ ----- (3)}$$

Now the equation for  $i(t)$  at equation (1) is differentiated to get

$$(di/dt) = -0.5A_1 e^{-0.5t} - 2A_2 e^{-2t}$$

and the above value of  $(di/dt)_{@ t=0} = 5$  is substituted in that to get the second equation with  $A_1$  and  $A_2$

$$(di/dt)_{@ t=0} = 5 = -0.5A_1 e^{-0.5 \times 0} - 2A_2 e^{-2 \times 0} = -0.5A_1 - 2A_2$$

Now we can solve the two equations for  $A_1$  and  $A_2$

$$A_1 + A_2 = 0 \quad \text{and} \quad -0.5A_1 - 2A_2 = 5 \quad \text{to get} \quad A_1 = 10/3 \quad \text{and} \quad A_2 = -10/3$$

**And the final solution for  $i(t)$  is :  $(10/3)[e^{-0.5t} - e^{-2t}]$  Amps**

(b) At time  $t=0$  the voltage across the capacitor = 5V i.e.  $v_C(t=0) = 5V$ . But  $i(t=0)$  is still =0. using these values in the equation (2) above we get

$$(di/dt)_{@ t=0} = \frac{1}{2} (10 - 5) = 2.5$$

Then the two equations in  $A_1$  and  $A_2$  are  $A_1 + A_2 = 0$  and  $-0.5A_1 - 2A_2 = 2.5$

Solving these two equations we get  $A_1 = 5/3$  and  $A_2 = -5/3$

**And the final solution for  $i(t)$  is :  $(5/3)[e^{-0.5t} - e^{-2t}]$  Amps**

(c) The roots of the characteristic equation when the Resistance is changed to 4

$$s_1, s_2 = -R/2L \pm \sqrt{[(R/2L)^2 - (1/LC)]} = (-4/2 \times 2) \pm \sqrt{[(4/2 \times 2)^2 - (1/2 \times 0.5)]} = -1.0$$

i.e the roots are real and equal and the solution is given by

$$i(t) = e^{-\alpha t} (A_1 t + A_2) = e^{-1t} (A_1 t + A_2) \text{ -----(4)}$$

Now using the initial condition  $i(t) = 0$  at time  $t=0$  we get  $A_2 = 0$

We have already found in equation (3) for the basic series RLC circuit  $(di/dt)_{@ t=0} = 5$



Now we will find  $di(t)/dt$  of equation (4) and equate it to the above value.

$$di/dt = -e^{-1t}(A_1t + A_2) + e^{-1t}(A_1) = e^{-1t} [A_1 - A_1t - A_2]$$
 and

$$(di/dt)_{@t=0} = e^{-1 \times 0} [A_1 - A_1 \times 0 - A_2] \text{ i.e } A_1 - A_2 = 5$$

Therefore  $A_1 = 5$  and  $A_2 = 0$

**And the final solution for  $i(t)$  is  $i(t) = 5te^{-1t}$  Amps**

(d) Roots of the characteristic equation when the resistance is changed to  $1 \Omega$  are :

$$s_1, s_2 = -R/2L \pm \sqrt{[(R/2L)^2 - (1/LC)]} = (-1/2 \times 2) \pm \sqrt{[(1/4)^2 - (1/2 \times 0.5)]} = -0.25 \pm j0.94$$

The roots are complex and so the solution is then given by :  $i(t) = e^{-\alpha t}(A_1 \cos \omega_d t + A_2 \sin \omega_d t)$

Where  $\alpha = 0.25$  and  $\omega_d = 0.9465$

Now we will apply the initial conditions to find out the constants  $A_1$  and  $A_2$

First initial condition is  $i(t)_{@t=0} = 0$  applying this into the equation :  $i(t) = e^{-\alpha t}(A_1 \cos \omega_d t + A_2 \sin \omega_d t)$

we get  $A_1 = 0$  and using this value of  $A_1$  in the above equation for  $i(t)$  we get

$$i(t) = e^{-\alpha t}(A_2 \sin \omega_d t)$$

We have already obtained the second initial condition as  $di(t)/dt_{@t=0} = 5$  from the basic equation of the series RLC circuit. Now let us differentiate above equation for current i.e :  $i(t) = e^{-\alpha t}(A_2 \sin \omega_d t)$  and equate it to 5 to get the second constant  $A_2$

$$di(t)/dt = e^{-\alpha t}(A_2 \omega_d \cos \omega_d t) + (A_2 \sin \omega_d t) \cdot -\alpha \cdot e^{-\alpha t}$$

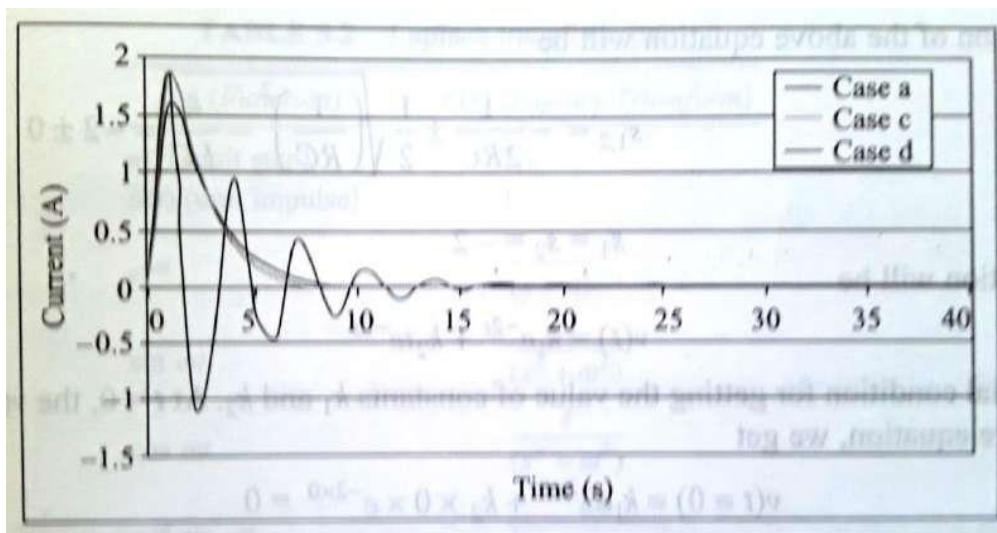
$$di(t)/dt \text{ @ } t=0 = A_2 \cdot \omega_d = 5$$

$$\text{i.e } A_2 = 5 / \omega_d = 5/0.94 = 5.3$$

Now using this value of  $A_2$  and the values of  $\alpha = 0.25$  and  $\omega_d = 0.94$  in the above expression for the current we finally get :

$$i(t) = e^{-0.25t}(2.569 \sin 1.9465t)$$

The currents in all the three different cases (a), (c) and (d) are shown below :



## UNIT - 3

### 3-PHASE CIRCUITS

#### Phase sequence

Phase sequence refers to the relation between voltages (or currents, as well) in a three-phase system. The common representation of this relation is in terms of a phasor diagram, as below

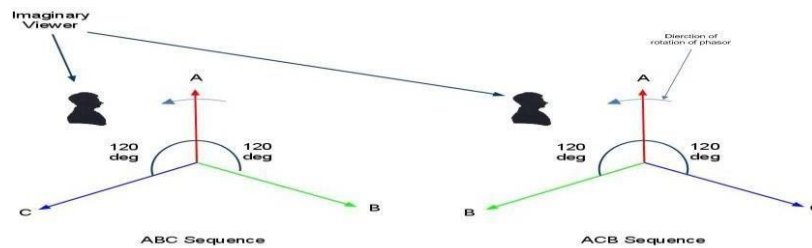
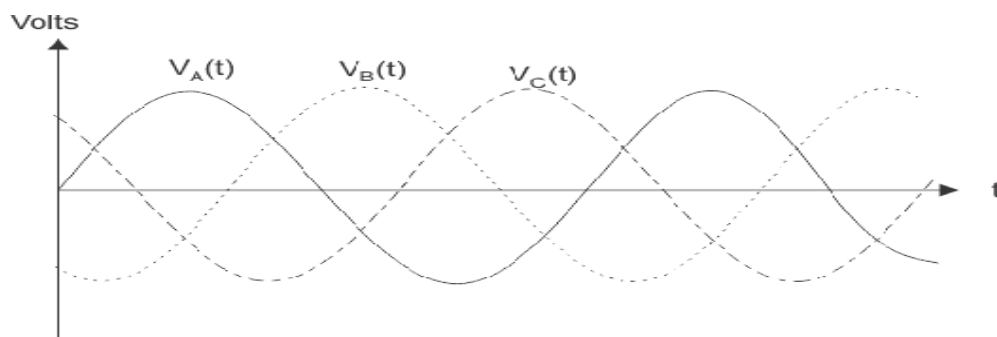


Fig A: ABC and ACB phase sequence, Anti clock wise Rotation

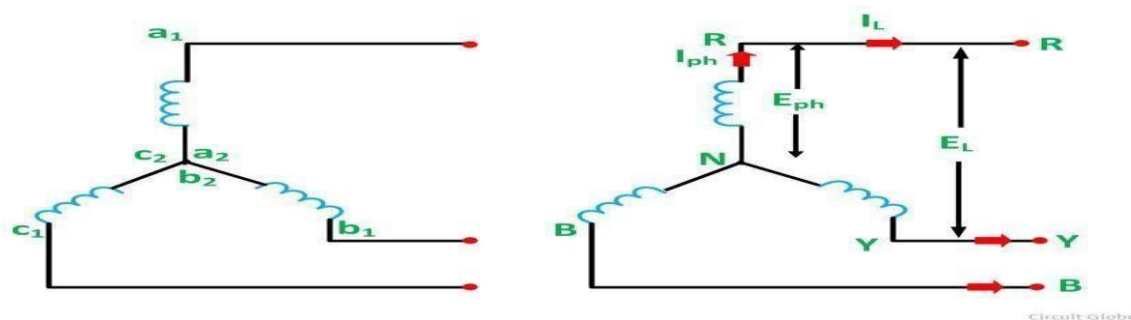
The phasor diagram represents the phasor (or vector) relation of the three phase-ground voltages (for simplicity, in a balanced system). The diagram is based on counter-clockwise rotation. In a three phase system the voltage or current sinusoid attain peak values periodically one after another. The sinusoids are displaced 120 degrees from each other. So also phasors representing the three sinusoids for voltage or current waves of three lines are phase displaced by 120 degrees. The order in which the three phase voltages attain their positive peak values is known as the phase sequence. Conventionally the three phases are designated as red-R, yellow-Y and blue-B phases. The phase sequence is said to be RYB if R attains its peak or maximum value first with respect to the reference as shown in the counter clockwise direction followed by Y phase  $120^\circ$  later and B phase  $240^\circ$  later than the R phase. The phase sequence is said to be RBY if R is followed by B phase  $120^\circ$  later and Y phase  $240^\circ$  later than the R phase. By convention RYB is considered as positive while the sequence RBY as negative. The phase sequence of the voltages applied to a load is determined by the order in which the 3 phase lines are connected. The phase sequence can be reversed by interchanging any one pair of lines without causing any change in the supply sequence. Reversal of sequence results in reversal of the direction of rotation in case of induction motor. Phase sequence is critical in measurements on power systems, and for

protective relaying, but perhaps most importantly, for rotating machines (so machines do not run backwards). Modern microprocessor protective relays have a selectable phase-sequence setting (often called the phase-rotation setting), so the relay adapts to the phase sequence without ordinarily requiring changes to the wiring connections. In the historic electromechanical relays (and meters), the wiring connections had to reflect the phase sequence to enable accurate measurements and protection.



**Inter connection of phases:** The three phases can be inter connected either in star (Y) or in delta ( $\Delta$ ). These connections result in a compact and a relatively economical system as the number of conductors gets reduced by 33% for a three phase 4 - wire star system and by 50% for 3phase 3 - wire star or delta systems when compared to independent connection of phases.

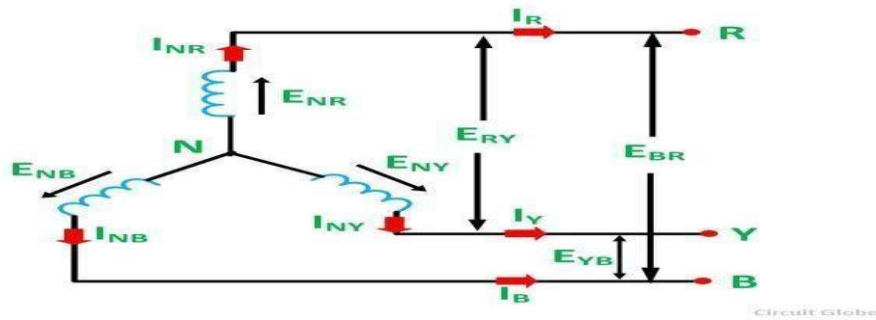
**Star connection:** In the **Star Connection**, the similar ends (either start or finish) of the three windings are connected to a common point called star or neutral point. The three line conductors run from the remaining three free terminals called **line conductors**. The wires are carried to the external circuit, giving three phase, three wire star connected systems. However, sometimes a fourth wire is carried from the star point to the external circuit, called **neutral wire**, forming three phase, four wire star connected systems. The star connection is shown in the diagram below.



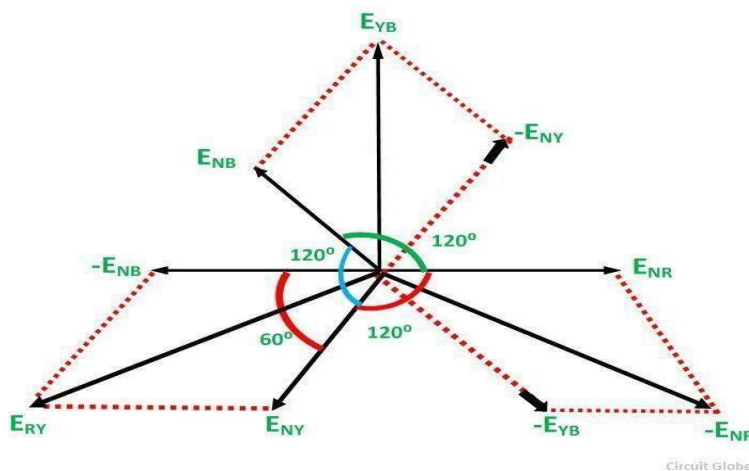
Considering the above figure, the finish terminals a2, b2, and c2 of the three windings are connected to form a star or neutral point. The three conductors named as R, Y and B run from the remaining three free terminals as shown in the above figure. The current flowing through each phase is called **Phase current  $I_{ph}$** , and the current flowing through each line conductor is called **Line Current  $I_L$** . Similarly, the voltage across each phase is called **Phase Voltage  $E_{ph}$** , and the voltage across two line conductors is known as the **Line Voltage  $E_L$** .

### Relation Between Phase Voltage and Line Voltage in Star Connection:

The Star connection is shown in the figure below.



As the system is balanced, a balanced system means that in all the three phases, i.e., R, Y and B, the equal amount of current flows through them. Therefore, the three voltages  $E_{NR}$ ,  $E_{NY}$  and  $E_{NB}$  are equal in magnitude but displaced from one another by 120 degrees electrical. The **Phasor Diagram** of Star Connection is shown below.



The arrowheads on the emfs and current indicate direction and not their actual direction at any instant. Now,

$$E_{NR} = E_{NY} = E_{NB} = E_{ph} \text{ (in magnitude)}$$

There are two phase voltages between any two lines. Tracing the loop NRYN

$$\overline{E_{NR}} + \overline{E_{RY}} - \overline{E_{NY}} = 0 \quad \text{or}$$

$$\overline{E_{RY}} = \overline{E_{NY}} - \overline{E_{NR}} \text{ (vector difference)}$$

To find the vector sum of  $E_{NY}$  and  $-E_{NR}$ , we have to reverse the vector  $E_{NR}$  and add it with  $E_{NY}$  as shown in the phasor diagram above. Therefore,

$$E_{RY} = \sqrt{E_{NY}^2 + E_{NR}^2 + 2E_{NY}E_{NR} \cos 60^\circ} \quad \text{or}$$

$$E_L = \sqrt{E_{ph}^2 + E_{ph}^2 + 2E_{ph}E_{ph} \times 0.5} \quad \text{or}$$

$$E_L = \sqrt{3E_{ph}^2} = \sqrt{3} E_{ph} \text{ (in magnitude)}$$

Similarly,

$$E_{YB} = E_{NB} - E_{NY} \quad \text{or} \quad E_L = \sqrt{3} E_{ph} \quad \text{and}$$

$$E_{BR} = E_{NR} - E_{NB} \quad \text{or} \quad E_L = \sqrt{3} E_{ph}$$

Hence, in Star Connections Line voltage is root 3 times of phase voltage.

$$\text{Line voltage} = \sqrt{3} \times \text{Phase voltage}$$

$$V_{RY} = V_{NR} - V_{NY} = V_r m s \angle 0^\circ - V_r m s \angle -120^\circ$$

$$= V_r m s [(\cos 0 + j \sin 0) - (\cos(-120) + j \sin(-120))]$$

$$\begin{aligned}
 &= V_{rms} \left[ 1 + \frac{1}{2} + j \frac{\sqrt{3}}{2} \right] = V_{rms} \left[ \frac{3 + j\sqrt{3}}{2} \right] = \sqrt{3} V_{rms} \left[ \frac{\sqrt{3} + j1}{2} \right] \\
 &= \sqrt{3} V_{rms} [1 \angle 30^\circ] \\
 &= \sqrt{3} V_{rms} \angle 30^\circ
 \end{aligned}$$

Similarly

$$V_{YB} = \sqrt{3} V_{rms} \angle -90^\circ$$

$$V_{BR} = \sqrt{3} V_{rms} \angle 150^\circ$$

If we compare the line-to-neutral voltages with the line-to-line voltages, we find the following relationships,

Line-to-neutral voltages

Line-to-line voltages

$$V_{an} = V_{rms} \angle 0^\circ$$

$$V_{ab} = \sqrt{3} V_{rms} \angle 30^\circ$$

$$V_{bn} = V_{rms} \angle -120^\circ$$

$$V_{bc} = \sqrt{3} V_{rms} \angle -90^\circ$$

$$V_{cn} = V_{rms} \angle 120^\circ$$

$$V_{ca} = \sqrt{3} V_{rms} \angle 150^\circ$$

**Line-to-line voltages in terms of line-to-neutral voltages:**

$$V_{ab} = \sqrt{3} V_{an} e^{j30^\circ}$$

$$V_{bc} = \sqrt{3} V_{bn} e^{j30^\circ}$$

$$V_{ca} = \sqrt{3} V_{cn} e^{j30^\circ}$$

**Relation Between Phase Current and Line Current in Star Connection**

The same current flows through phase winding as well as in the line conductor as it is connected in series with the phase winding.

$$I_R = I_{NR}$$

$$I_Y = I_{NY} \quad \text{and}$$

$$I_B = I_{NB}$$

$$I_{NR} = I_{NY} = I_{NB} = I_{ph}$$

$$I_R = I_Y = I_B = I_L$$

Hence, in a 3 Phase system of Star Connections, the Line Current is equal to Phase Current.

### Power in Star Connection

In a three phase AC circuit, the total True or Active power is the sum of the three phase power.

Or the sum of the all three phase powers is the Total **Active or True Power**.

Hence, total active or true power in a three phase AC system;

Total True or Active Power = 3 Phase Power

Or

$$P = 3 \times V_{PH} \times I_{PH} \times \cos\Phi \dots \text{Eq ... (1)}$$

**Good to Know:** Where  $\cos\Phi$  = Power factor = the phase angle between Phase Voltage and Phase Current and not between Line current and line voltage. We know that the values of Phase Current and Phase Voltage in Star Connection;

$$I_L = I_{PH}$$

$$V_{PH} = V_L / \sqrt{3} \dots \text{(From } V_L = \sqrt{3} V_{PH}\text{)}$$

Putting these values in power eq..... (1)

$$P = 3 \times (V_L / \sqrt{3}) \times I_L \times \cos\Phi \dots \dots \dots (V_{PH} = V_L / \sqrt{3})$$

$$P = \sqrt{3} \times \sqrt{3} \times (V_L / \sqrt{3}) \times I_L \times \cos\Phi \quad \{3 = \sqrt{3} \times \sqrt{3}\}$$

$$P = \sqrt{3} \times V_L \times I_L \times \cos\Phi$$

Hence proved;

Power in Star Connection,

$$P = 3 \times V_{PH} \times I_{PH} \times \cos\Phi \text{ or}$$

$$P = \sqrt{3} \times V_L \times I_L \times \cos\Phi$$

Similarly,

$$\text{Total Reactive Power} = Q = \sqrt{3} \times V_L \times I_L \times \sin\Phi$$

**Good to know:** Reactive Power of Inductive coil is taken as Positive (+) and that of a Capacitor as Negative (-).

Also, the total apparent power of the three phases

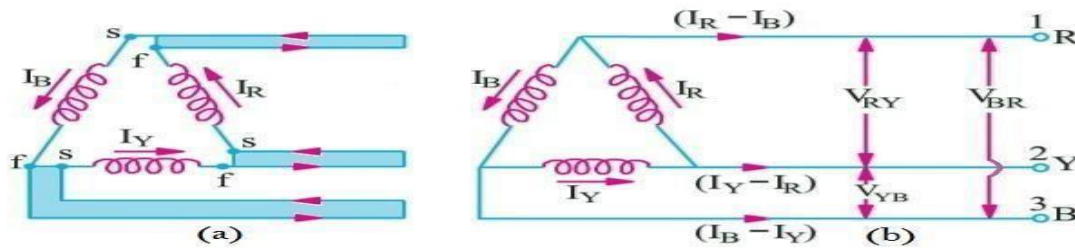
$$\text{Total Apparent Power} = S = \sqrt{3} \times V_L \times I_L$$

$$\text{Or, } S = \sqrt{P^2 + Q^2}$$

### Delta Connection In a 3 Phase System :

In this system of interconnection, the starting ends of the three phases or coils are connected to the finishing ends of the coil. Or the starting end of the first coil is connected to the finishing end of the second coil and so on (for all three coils) and it looks like a closed mesh or circuit as shown in fig (1). In more clear words, all three coils are connected in series to form a close mesh or circuit. Three wires are taken out from three junctions and the all outgoing currents from junction assumed to be positive. In Delta connection, the three windings interconnection looks like a short circuit, but this is not true, if the system is balanced, then the value of the algebraic

sum of all voltages around the mesh is zero. When a terminal is open, then there is no chance of flowing currents with basic frequency around the closed mesh.



© www.electricaltechnology.org

### Delta Connection ( $\Delta$ ): 3 Phase Power, Voltage & Current Values

#### 1. Line Voltages and Phase Voltages in Delta Connection

It is seen from fig 2 that there is only one phase winding between two terminals (i.e. there is one phase winding between two wires). Therefore, in Delta Connection, the voltage between (any pair of) two lines is equal to the phase voltage of the phase winding which is connected between two lines. Since the phase sequence is  $R \rightarrow Y \rightarrow B$ , therefore, the direction of voltage from R phase towards Y phase is positive (+), and the voltage of R phase is leading by  $120^\circ$  from Y phase voltage. Likewise, the voltage of Y phase is leading by  $120^\circ$  from the phase voltage of B and its direction is positive from Y towards B.

If the line voltage between; Line 1 and Line 2 =  $V_{RY}$  ;

Line 2 and Line 3 =  $V_{YB}$  ; ; Line 3 and Line 1 =  $V_{BR}$

Then, we see that  $V_{RY}$  leads  $V_{YB}$  by  $120^\circ$  and  $V_{YB}$  leads  $V_{BR}$  by  $120^\circ$ .

Let's suppose,

$V_{RY} = V_{YB} = V_{BR} = V_L$  ..... (Line Voltage)

Then  $V_L = V_{PH}$

I.e. in Delta connection, the Line Voltage is equal to the Phase Voltage.

#### 2. Line Currents and Phase Currents in Delta Connection

It will be noted from the below (fig-2) that the total current of each Line is equal to the vector difference

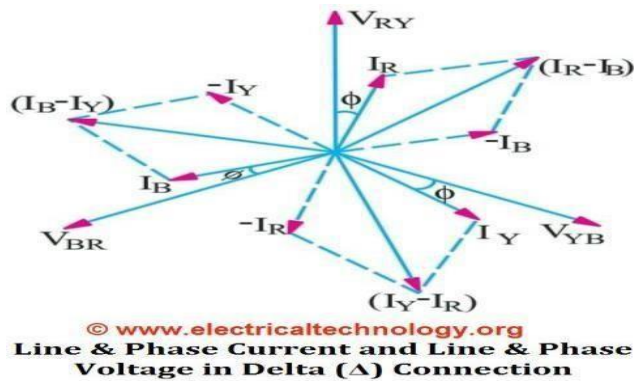
between two phase currents flowing through that line. i.e.;

□□ Current in Line 1 =  $I_1 = I_R - I_B$

□□ Current in Line 2 =  $I_2 = I_Y - I_R$

□□ Current in Line 3 =  $I_3 = I_B - I_Y$





The current of Line 1 can be found by determining the vector difference between  $I_R$  and  $I_B$  and we can do

that by increasing the  $I_B$  Vector in reverse, so that,  $I_R$  and  $I_B$  makes a parallelogram. The diagonal of that parallelogram shows the vector difference of  $I_R$  and  $I_B$  which is equal to Current in Line 1 =  $I_1$ . Moreover, by reversing the vector of  $I_B$ , it may indicate as  $(-I_B)$ , therefore, the angle between  $I_R$  and  $-I_B$  ( $I_B$ , when reversed =  $-I_B$ ) is  $60^\circ$ .

If,  $I_R = I_Y = I_B = I_{PH}$  .... The phase currents Then;

The current flowing in Line 1 would be;

$$I_L \text{ or } I_1 = \sqrt{(I_R^2 + I_Y^2 + 2 \cdot I_R \cdot I_Y \cos 60^\circ)}$$

i.e. In Delta Connection, The Line current is  $\sqrt{3}$  times of Phase Current

Similarly, we can find the remaining two Line currents as same as above. i.e.,

$$I_2 = I_Y - I_R \dots \text{Vector Difference} = \sqrt{3} I_{PH}$$

$$I_3 = I_B - I_Y \dots \text{Vector difference} = \sqrt{3} I_{PH}$$

As, all the Line current are equal in magnitude i.e.

$$I_1 = I_2 = I_3 = I_L$$

Hence

$$I_L = \sqrt{3} I_{PH}$$

It is seen from the fig above that;

□□ The Line Currents are  $120^\circ$  apart from each other

□□ Line currents are lagging by  $30^\circ$  from their corresponding Phase Currents

□□ The angle  $\Phi$  between line currents and respective line voltages is  $(30^\circ + \Phi)$ , i.e. each line current is

lagging by  $(30^\circ + \Phi)$  from the corresponding line voltage.

### 3. Power in Delta Connection

We know that the power of each phase

$$\text{Power / Phase} = V_{PH} \times I_{PH} \times \cos\Phi$$

And the total power of three phases;

$$\text{Total Power} = P = 3 \times V_{PH} \times I_{PH} \times \cos\Phi \dots (1)$$

We know that the values of Phase Current and Phase Voltage in Delta Connection;

$$I_{PH} = I_L / \sqrt{3} \dots (\text{From } I_L = \sqrt{3} I_{PH})$$

$$V_{PH} = V_L$$

Putting these values in power eq..... (1)

$$P = 3 \times V_L \times (I_L / \sqrt{3}) \times \cos\Phi \dots (I_{PH} = I_L / \sqrt{3})$$

$$P = \sqrt{3} \times \sqrt{3} \times V_L \times (I_L / \sqrt{3}) \times \cos\Phi \dots \{ 3 = \sqrt{3} \times \sqrt{3} \}$$

$$P = \sqrt{3} \times V_L \times I_L \times \cos\Phi \dots$$

Hence proved;

Power in Delta Connection,

$$P = 3 \times V_{PH} \times I_{PH} \times \cos\Phi \dots \text{or}$$

$$P = \sqrt{3} \times V_L \times I_L \times \cos\Phi$$

**Good to Know:** Where  $\cos\Phi$  = Power factor = the phase angle between Phase Voltage and Phase Current and not between Line current and line voltage.

#### **Good to Remember:**

In both Star and Delta Connections, The total power on balanced load is same.

$$\text{I.e. total power in a Three Phase System} = P = \sqrt{3} \times V_L \times I_L \times \cos\Phi$$

#### **Good to know:**

**Balanced System is a system where:**

□□ All three phase voltages are equal in magnitude

□□ All phase voltages are in phase by each other i.e.  $360^\circ/3 = 120^\circ$

□□ All three phase Currents are equal in magnitude

□□ All phase Currents are in phase by each other i.e.  $360^\circ/3 = 120^\circ$

□□ A three phase balanced load is a system in which the load connected across three phases are identical.

#### **Analysis of Balanced Three Phase Circuits:**

It is always better to solve the balanced three phase circuits on per phase basis. When the three phase supply voltage is given without reference to the line or phase value, then it is the line voltage which is taken into consideration.

**The following steps are given below to solve the balanced three phase circuits.**

**Step 1** – First of all draw the circuit diagram.

**Step 2** – Determine  $X_L = \omega L / \text{phase} = 2\pi fL$ .

**Step 3** – Determine  $X_C = 1 / \omega C / \text{phase} = 1 / 2\pi fC$ .

**Step 4** – Determine  $X_P = X / \text{phase} = X_L - X_C$

**Step 5** – Determine  $Z_P = Z / \text{phase} = \sqrt{R^2 + X_P^2}$

**Step 6** – Determine  $\cos\phi = R_P / Z_P$ ; the power factor is lagging when  $X_L > X_C$  and it is leading when  $X_C > X_L$ .

**Step 7** – Determine  $V_{\text{phase}}$ . For star connection  $V_P = V_L / \sqrt{3}$  and for delta connection  $V_P = V_L$

**Step 8** – Determine  $I_P = V_P / Z_P$ .

**Step 9** – Now, determine the line current  $I_L$ . For star connection  $I_L = I_P$  and for delta connection  $I_L = \sqrt{3} I_P$

**Step 10** – Determine the Active, Reactive and Apparent power.

### **THREE-PHASE CONNECTIONS:**

The sources and loads in a three-phase system can each be connected in either a *wye* (Y) or *delta* ( $\Delta$ ) configuration. Note that the wye connections are line-to-neutral while the delta connections are line-to-line with no neutral. Also note the convention on the node designations (lowercase letters at the source connections and uppercase letters at the load connections). Both the three phase source and the three phase load can be connected either Wye or DELTA.

We have 4 possible connection types.

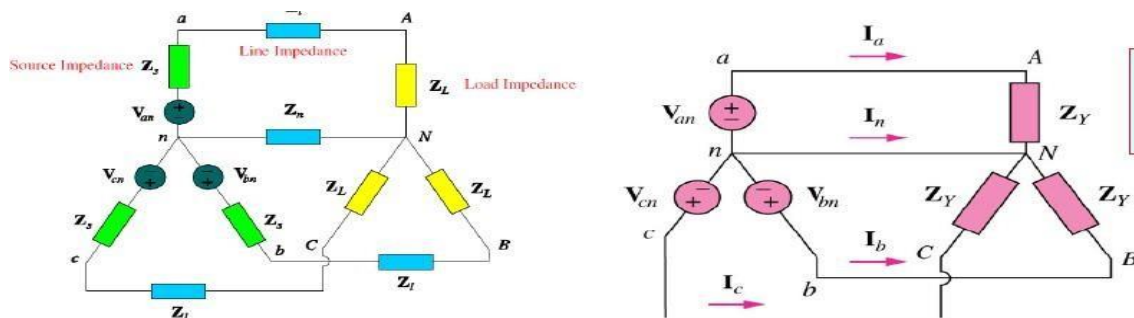
1. Y-Y connection
2. Y- $\Delta$  connection
3.  $\Delta$ - Y connection
4.  $\Delta$  - $\Delta$  connection

Balanced  $\Delta$  connected load is more common & Y connected sources are more common.

### **BALANCED WYE-WYE CONNECTION**

The balanced three-phase wye-wye connection is shown below. Note that the line impedance for each of the individual phases is included in the circuit. The line impedances are assumed to be equal for all three phases. The *line currents* ( $I_a$ ,  $I_b$  and  $I_c$ ) are designated according to the source/load node naming convention. The *source* current, *line* current, and *load* current are all one in the same current for a given phase in a wye-wye connection. Wye source Wye load

Assuming a positive phase sequence, the application of Kirchoff's voltage law around each phase gives where  $Z_{total}$



Assuming a positive phase sequence, the application of Kirchoff's voltage law around each phase gives

$$V_{an} = V_{rms} \angle 0^\circ = I_a(Z_l + Z_L) = I_a Z_{total} = I_a |Z_{total}| \angle \theta_Z$$

$$V_{bn} = V_{rms} \angle -120^\circ = I_b(Z_l + Z_L) = I_b Z_{total} = I_b |Z_{total}| \angle \theta_Z$$

$$V_{cn} = V_{rms} \angle 120^\circ = I_c(Z_l + Z_L) = I_c Z_{total} = I_c |Z_{total}| \angle \theta_Z$$

Where  $Z_{total}$  is the total impedance in each phase and  $\theta_Z$  is the phase angle associated with the total phase impedance. The preceding equations can be solved for the line currents.

#### Line Currents

$$I_a = \frac{V_{rms}}{|Z_{total}|} \angle (-\theta_Z)$$

$$I_b = \frac{V_{rms}}{|Z_{total}|} \angle (-120^\circ - \theta_Z)$$

$$I_c = \frac{V_{rms}}{|Z_{total}|} \angle (120^\circ - \theta_Z)$$

#### Line-to-neutral voltages

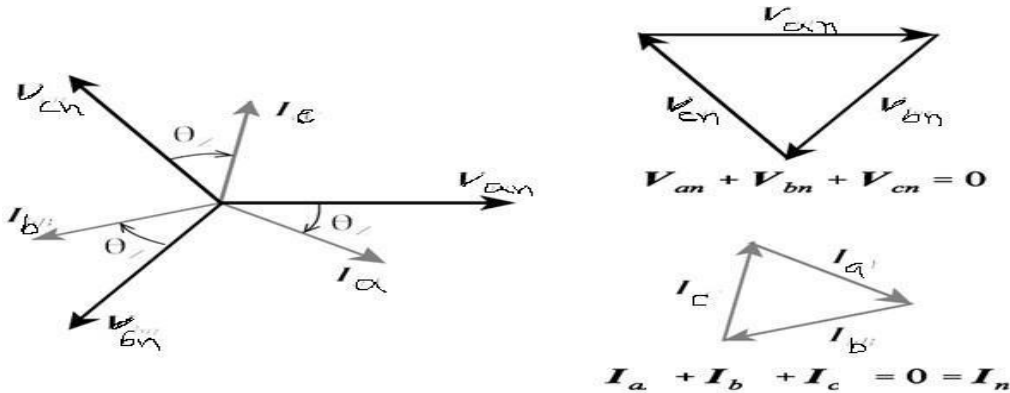
$$V_{an} = V_{rms} \angle 0^\circ$$

$$V_{bn} = V_{rms} \angle -120^\circ$$

$$V_{cn} = V_{rms} \angle 120^\circ$$

Note that the line current magnitudes are equal and each line current lags the respective line-to-neutral voltage by the impedance phase angle  $2\theta_Z$ . Thus, the balanced voltages yield balanced

currents. The phasor diagram for the line currents and the line-to-neutral voltages is shown below. If we lay the line-to neutral voltage phasors end to end, they form a closed triangle (the same property is true for the line currents). The closed triangle shows that the sum of these phasors is zero.



The fact that the line currents sum to zero in the balanced wye-wye connection shows that the neutral current  $I_n$  is zero in this balanced system. Thus, the impedance of the neutral is immaterial to the performance of the circuit under balanced conditions. However, any imbalance in the system (loads, line impedances, source variations, etc.) will produce a non-zero neutral current. In any balanced three-phase system (balanced voltages, balanced line and load impedances), the resulting currents are balanced. Thus, there is no real need to analyze all three phases. We may analyze one phase to determine its current, and infer the currents in the other phases based on a simple balanced phase shift (120° phase difference between any two line currents). This technique is known as the *per phase analysis*.

Line current  $I_n$  add up to zero.  
**Neutral current is zero:**

$$I_n = -(I_a + I_b + I_c) = 0$$

➤ Magnitude of line voltages is  $\sqrt{3}$  times the magnitude of phase voltages.  $V_L = \sqrt{3} V_p$

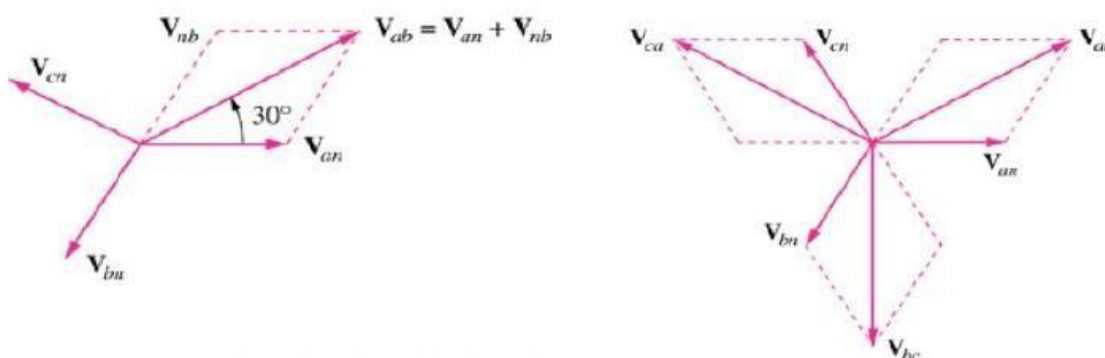
$$V_{an} = V_p \angle 0^\circ, \quad V_{bn} = V_p \angle -120^\circ, \quad V_{cn} = V_p \angle +120^\circ$$

$$V_{ab} = V_{an} + V_{nb} = V_{an} - V_{bn} = \sqrt{3}V_p \angle 30^\circ$$

$$V_{bc} = V_{bn} - V_{cn} = \sqrt{3}V_p \angle -90^\circ$$

$$V_{ca} = V_{cn} - V_{an} = V_{an} + V_{bn} = \sqrt{3}V_p \angle -210^\circ$$

➤ Phasor diagram of phase and line voltages

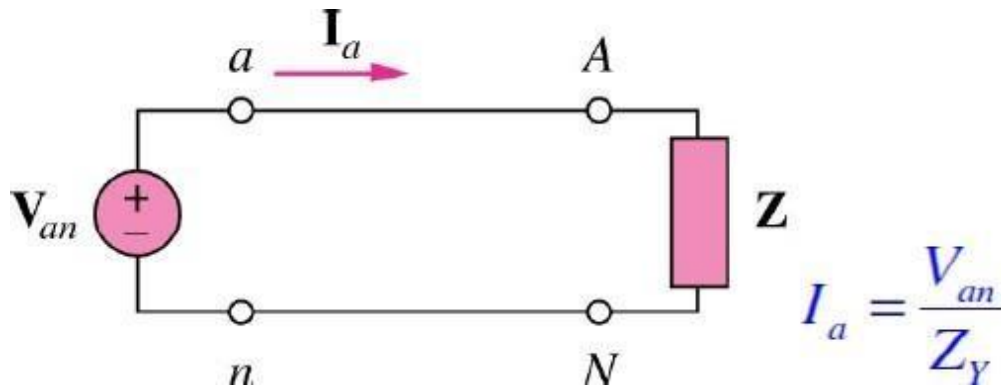


$$\begin{aligned} V_L &= |V_{ab}| = |V_{bc}| = |V_{ca}| \\ &= \sqrt{3} |V_{an}| = \sqrt{3} |V_{bn}| = \sqrt{3} |V_{cn}| = \sqrt{3} V_p \end{aligned}$$

$$V_p = |V_{an}| = |V_{bn}| = |V_{cn}|$$

### Single Phase Equivalent of Balanced Y-Y Connection:

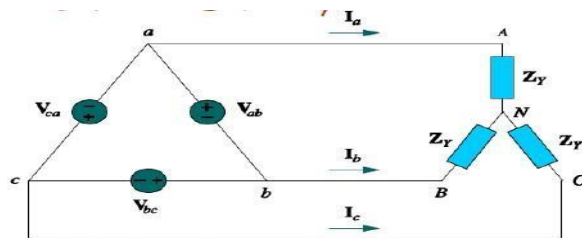
Balanced three phase circuits can be analyzed on “per phase “ basis. We look at one phase, say phase  $a$  and analyze the single phase equivalent circuit. Because the circuit is balanced, we can easily obtain other phase values using their phase relationships.



In addition to the wye-wye three-phase connection, there are three other possible configurations of wye and delta sources and loads. The most efficient way to handle three-phase circuits containing delta sources and/or loads is to transform all delta connections into wye connections.

**Delta Source - Source Voltage and Source Current Calculations: Source Voltage:**

Given that a delta source is defined in terms of line-to-line voltages while the wye source is defined in terms of line-to-neutral voltages, we can use the previously determined relationship between line-to-line voltages and line-to neutral voltages to perform the transformation.



Transforming a Delta connected source to an equivalent Wye connection

Single phase equivalent of Delta Wye connection

$$V_{ab} = \sqrt{3} V_{an} e^{j30^\circ} \quad V_{bc} = \sqrt{3} V_{bn} e^{j30^\circ} \quad V_{ca} = \sqrt{3} V_{cn} e^{j30^\circ}$$

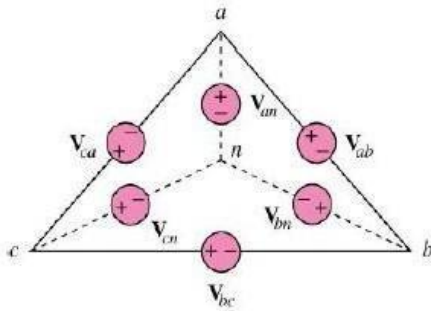
thus, line-to-neutral voltages in a wye-connected source that are equivalent to the line-to-line voltages in the delta-connected source are

$$V_{an} = \frac{V_{ab}}{\sqrt{3}} e^{-j30^\circ}$$

$$V_{bn} = \frac{V_{bc}}{\sqrt{3}} e^{-j30^\circ}$$

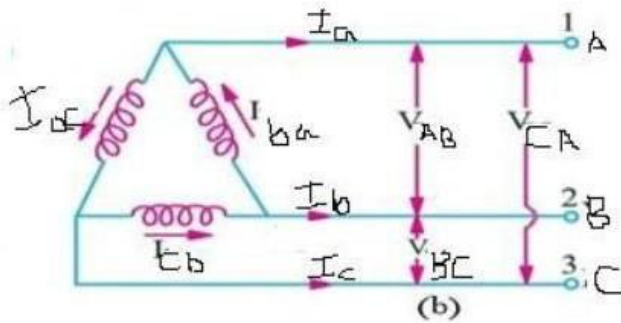
$$V_{cn} = \frac{V_{ca}}{\sqrt{3}} e^{-j30^\circ}$$

Thus, we simply divide the appropriate line-to-line voltage in the delta source by  $\sqrt{3}$  and subtract 30 from its phase angle to find the corresponding line-to-neutral voltages for the wye source



**Source Current:**

The delta source line currents ( $I_a, I_b, I_c$ ) are related to the corresponding source currents ( $I_{ba}, I_{cb}, I_{ca}$ ) according to Kirchoff's current law.

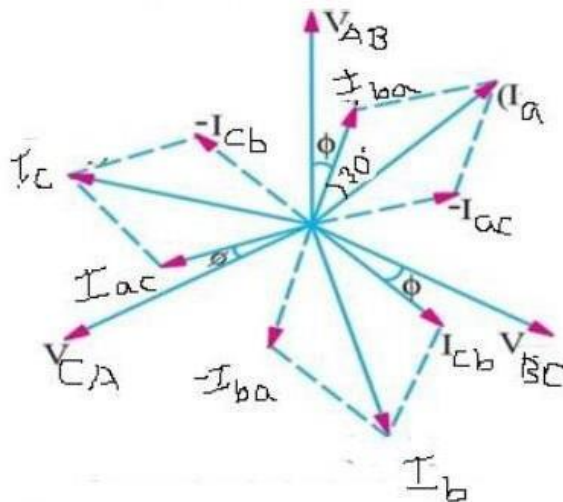


$$I_a = I_{bc} - I_{ac} \quad I_b = I_{c} - I_{ba} \quad I_c = I_{ac} - I_{cb}$$

Assuming a balanced three-phase system with source currents defined by

$$I_{ba} = I_{rms} \angle (\theta) \quad I_{cb} = I_{rms} \angle (\theta - 120) \quad I_{ac} = I_{rms} \angle (\theta + 120)$$

the resulting phasor diagram relating the source and line currents is shown below.





The phasor diagram shows that the source currents in a delta source lead the line currents by  $30^\circ$  and are  $\sqrt{3}$  times the magnitude.

$$I_{ba} = \frac{I_a}{\sqrt{3}} e^{j30^\circ}$$

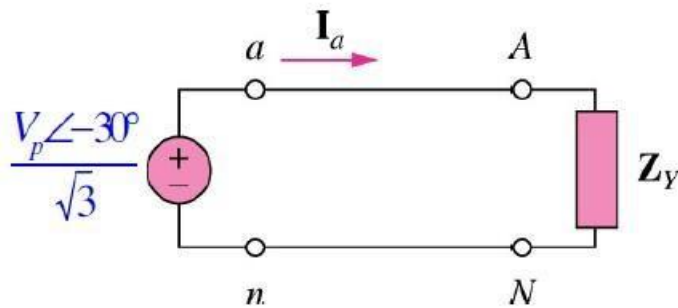
$$I_{cb} = \frac{I_b}{\sqrt{3}} e^{j30^\circ}$$

$$I_{ac} = \frac{I_c}{\sqrt{3}} e^{j30^\circ}$$

Summary: Delta Source ( $I_s, V_s$ ) in terms of Wye Source ( $I_s, V_s$ )

$$\begin{aligned} V_{ab} &= \sqrt{3} V_{an} e^{j30^\circ} & I_{ba} &= \frac{I_a}{\sqrt{3}} e^{j30^\circ} \\ V_{bc} &= \sqrt{3} V_{bn} e^{j30^\circ} & I_{cb} &= \frac{I_b}{\sqrt{3}} e^{j30^\circ} \\ V_{ca} &= \sqrt{3} V_{cn} e^{j30^\circ} & I_{ac} &= \frac{I_c}{\sqrt{3}} e^{j30^\circ} \end{aligned}$$

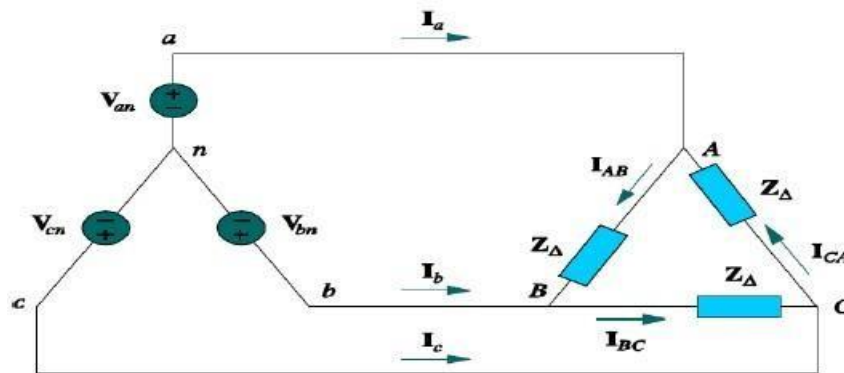
The single phase equivalent circuit can be drawn as below



**Delta Load - Load Current and Line Current Relationship:**

Three phase sources are usually Wye connected and three phase loads are Delta connected.

There is no neutral connection for the Y- Δ system.



$$\begin{aligned} I_{AB} &= \frac{V_{AB}}{Z_\Delta} \\ I_{BC} &= \frac{V_{BC}}{Z_\Delta} \\ I_{CA} &= \frac{V_{CA}}{Z_\Delta} \end{aligned}$$

Line currents are obtained from the phase currents  $I_{AB}$ ,  $I_{BC}$  and  $I_{CA}$

$$I_a = I_{AB} - I_{CA} = I_{AB} \sqrt{3} \angle -30^\circ$$

$$I_b = I_{BC} - I_{AB} = I_{BC} \sqrt{3} \angle -30^\circ$$

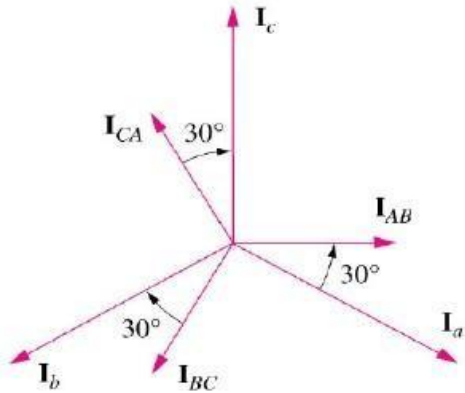
$$I_c = I_{CA} - I_{BC} = I_{CA} \sqrt{3} \angle -30^\circ$$

$$I_L = |I_a| = |I_b| = |I_c|$$

$$I_p = |I_{AB}| = |I_{BC}| = |I_{CA}|$$

$$I_L = \sqrt{3} I_p$$

Phasor diagram of phase and line currents

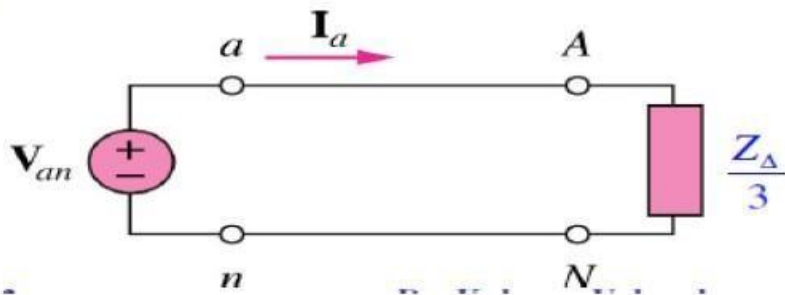


$$I_L = |I_a| = |I_b| = |I_c|$$

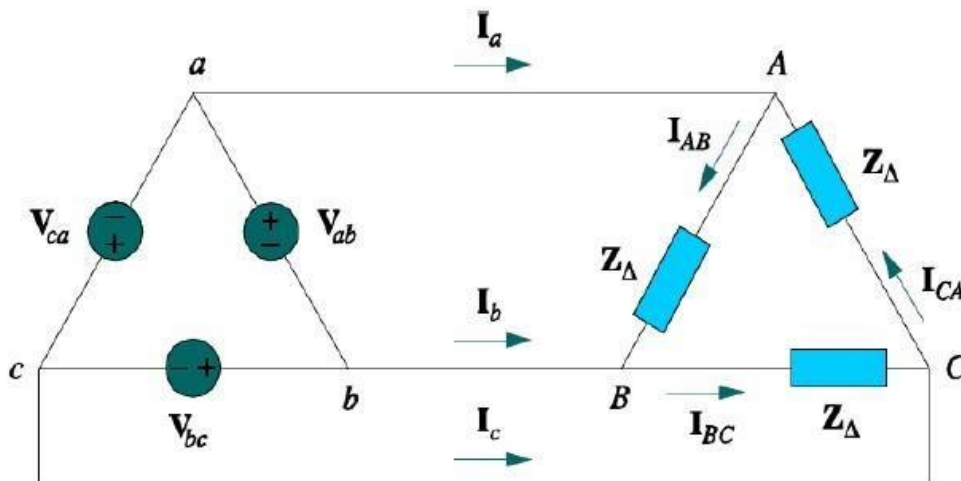
$$I_p = |I_{AB}| = |I_{BC}| = |I_{CA}|$$

$$I_L = \sqrt{3} I_p$$

Single phase equivalent circuit of the balanced Wye-delta connection



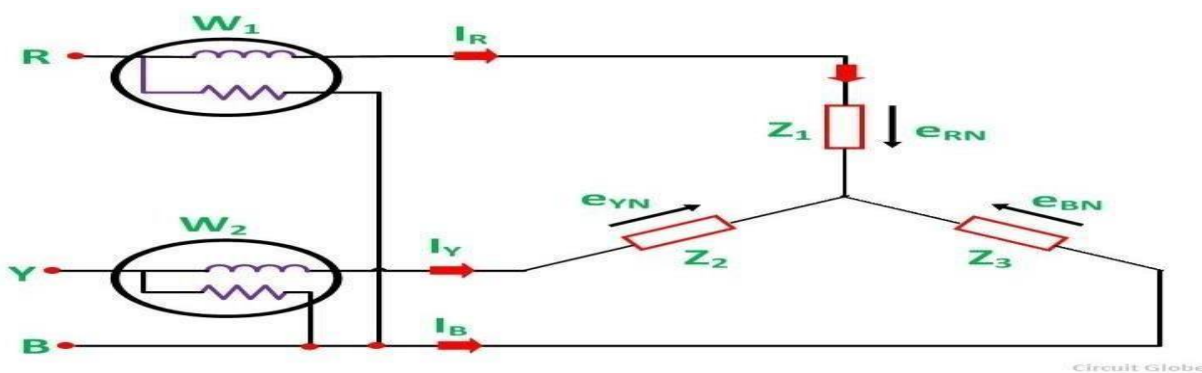
Balanced Delta-delta Connection:



### Two Wattmeter Method of Power Measurement:

**Two Wattmeter Method** can be employed to measure the power in a 3 phase, 3 wire star or delta connected balanced or unbalanced load. In Two wattmeter method the current coils of the wattmeter are connected with any two lines, say R and Y and the potential coil of each wattmeter is joined across the same line, the third line i.e. B as shown below in the figure A.

### Measurement of Power by Two Wattmeter Method in Star Connection:



Considering the above figure A in which Two Wattmeter  $W_1$  and  $W_2$  are connected, the instantaneous current through the current coil of Wattmeter,  $W_1$  is given by the equation shown below.

$$W_1 = i_R$$

Instantaneous potential difference across the potential coil of Wattmeter,  $W_1$  is given as

$$W_1 = e_{RN} - e_{BN}$$

Instantaneous power measured by the Wattmeter,  $W_1$  is

$$W_1 = i_R (e_{RN} - e_{BN}) \dots \dots \dots (1)$$

The instantaneous current through the current coil of Wattmeter,  $W_2$  is given by the equation

$$W_2 = i_Y$$

Instantaneous potential difference across the potential coil of Wattmeter, W2 is given as

$$W_2 = e_{YN} - e_{BN}$$

Instantaneous power measured by the Wattmeter, W2 is

$$W_2 = i_Y (e_{YN} - e_{BN}) \dots \dots \dots (2)$$

Therefore, the Total Power Measured by the Two Wattmeters W1 and W2 will be obtained by adding the equation (1) and (2).

$$W_1 + W_2 = i_R (e_{RN} - e_{BN}) + i_Y (e_{YN} - e_{BN})$$

$$W_1 + W_2 = i_R e_{RN} + i_Y e_{YN} - e_{BN} (i_R + i_Y) \text{ or}$$

$$W_1 + W_2 = i_R e_{RN} + i_Y e_{YN} + i_B e_{BN} \quad (\text{i.e. } i_R + i_Y + i_B = 0)$$

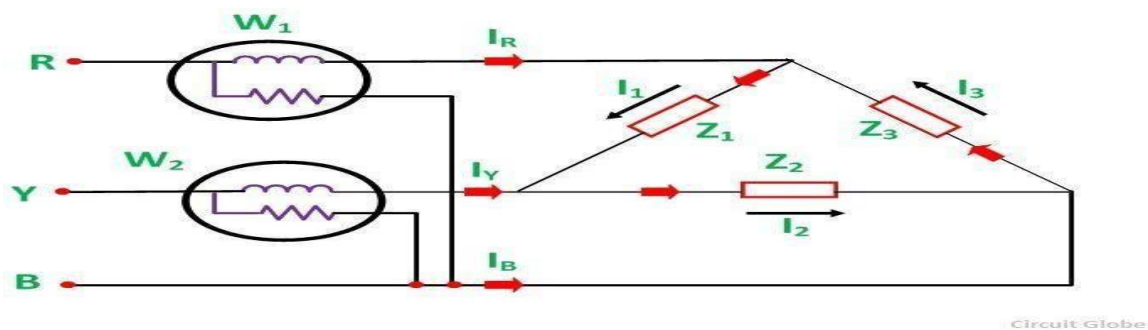
$$W_1 + W_2 = P$$

Where, P is the total power absorbed in the three loads at any instant.

Hence, the total instantaneous power absorbed by the three loads Z1, Z2 and Z3, are equal to the sum of the powers measured by the Two watt meters, W1 and W2.

**Measurement of Power by Two Wattmeter Method in Delta Connection**

Considering the delta connected circuit shown in the figure below,



The instantaneous current through the coil of the Wattmeter, W1 is given by the equation

$$W_1 = i_R = i_1 - i_3$$

Instantaneous voltage measured by the Wattmeter, W1 will be

$$W_1 = e_{RB}$$

Therefore, the instantaneous power measured by the Wattmeter, W1 will be given as

$$W_1 = e_{RB} (i_1 - i_3) \dots \dots \dots (3)$$

The instantaneous current through the current coil of the Wattmeter, W2 is given as

$$W_2 = i_Y = i_2 - i_1$$

The instantaneous potential difference across the potential coil of Wattmeter, W2 is

$$W_2 = e_{YB}$$

Therefore, the instantaneous power measured by Wattmeter, W2 will be

$$W_2 = e_{YB} (i_2 - i_1) \dots \dots \dots (4)$$

Hence, to obtain the total power measured by the Two Wattmeter the two equations, i.e. equation (3) and (4) has to be added.

$$W_1 + W_2 = e_{RB} (i_1 - i_3) + e_{YB} (i_2 - i_1)$$

$$W_1 + W_2 = i_1 e_{RB} + i_1 e_{YB} - i_3 e_{RB} - i_1 e_{YB}$$

$$W_1 + W_2 = i_2 e_{YB} + i_3 e_{BR} - i_1 (e_{YB} + e_{BR}) \quad (\text{i.e. } -e_{RB} = e_{BR})$$

$$W_1 + W_2 = i_1 e_{RY} + i_2 e_{YB} + i_3 e_{BR} \quad (\text{i.e. } e_{RY} + e_{YB} + e_{BR} = 0)$$

$$W_1 + W_2 = P$$

Where, P is the total power absorbed in the three loads at any instant. The power measured by the Two Wattmeter at any instant is the instantaneous power absorbed by the three loads connected in three phases. In fact, this power is the average power drawn by the load since the Wattmeter reads the average power because of the inertia of their moving system.

**Alternate method:**

### **THREE PHASE REAL POWER MEASUREMENTS**

The three phase real power is given by,

$$P_{3ph} = 3 V_{ph} I_{ph} \cos \phi$$
$$P_{3ph} = \sqrt{3} V_L I_L \cos \phi$$

The three phase power can be measured by using either one wattmeter, two watt meters or three watt meters in the measuring circuit. Of these, the two wattmeter method is widely used for the obvious advantages of measurements involved in it as discussed below.

#### Single Wattmeter Method

Here only one wattmeter is used for measurement of three phase power. For circuits with the balanced loads, we have:  $W_{3ph} = 3(\text{wattmeter reading})$ . For circuits with the unbalanced loads, we have:  $W_{3ph} = \text{sum of the three readings obtained separately by connecting wattmeter in each of the three phases}$ . If the neutral point is not available (3 phase 3 wire circuits) then an artificial neutral is created for wattmeter connection purposes. Instead three wattmeters can be connected simultaneously to measure the three phase power. However, this involves more number of meters to be used for measurements and hence is not preferred in practice. Instead, the three phase power can be easily measured by using only two wattmeter method.

#### Two Wattmeter Method

The circuit diagram for two wattmeter method of measurement of three phase real power is as shown in the figure 4.7. The current coil of the wattmeters W1 and W2 are inserted respectively in R and Y phases. The potential coils of the two wattmeters are joined together to phase B, the third phase. Thus, the voltage applied to the voltage coil of the meter, W1 is  $V_{RB} = V_R - V_B$ , while the voltage applied to the

voltage coil of the meter,  $W_2$  is  $V_{YB} = V_Y - V_B$ , where,  $V_R$ ,  $V_B$  and  $V_C$  are the phase voltage values lines R, Y and B respectively, as illustrated by the phasor diagram of figure 4.8. Thus, the reading of two wattmeters can be obtained based on the phasor diagram of figure 4.8, as follows:

$$W_1 = I_R V_{RB} = I_L V_L \cos(30^\circ - \phi) \tag{4.9}$$

$$W_2 = I_Y V_{YB} = I_L V_L \cos(30^\circ + \phi) \tag{4.10}$$

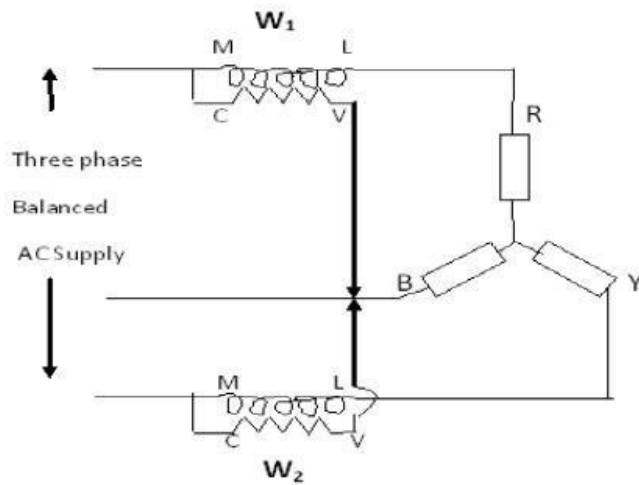
Hence,  $W_1 + W_2 = \sqrt{3} V_L I_L \cos \phi = P_{3ph}$  (4.11)

And  $W_1 - W_2 = V_L I_L \sin \phi$  (4.12)

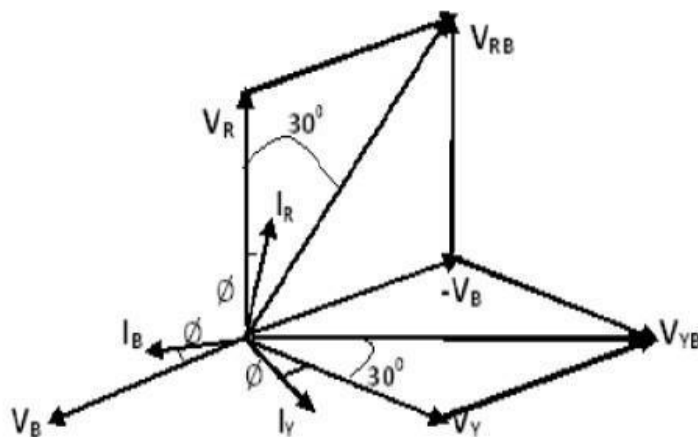
So that then,

$$\tan \phi = \sqrt{3} [W_1 - W_2] / [W_1 + W_2] \tag{4.13}$$

Where  $\phi$  is the lagging PF angle of the load. It is to be noted that the equations (4.11) and (4.12) get exchanged if the load is considered to be of leading PF.



Two wattmeter method of 3-phase power measurement



## Phasor diagram for real power measurements

The readings of the two wattmeters used for real power measurements in three phase circuits as above vary with the load power factor as described in the table 4.1.

PF angle	PF	$W_1$	$W_2$	$W_{3ph}=W_1+W_2$	Remarks
$\phi$ (lag)	$\cos \phi$	$V_L I_L \cos(30-\phi)$	$V_L I_L \cos(30+\phi)$	$\sqrt{3} V_L I_L \cos \phi$	Gen. Case (always $W_1 \geq W_2$ )
$0^\circ$	UPF	$\sqrt{3}/2 V_L I_L$	$\sqrt{3}/2 V_L I_L$	$2W_1$ or $2W_2$	$W_1=W_2$
$30^\circ$	0.866	$V_L I_L$	$V_L I_L/2$	$1.5W_1$ or $3W_2$	$W_2=W_1/2$
$60^\circ$	0.5	$\sqrt{3}/2 V_L I_L$	ZERO	$W_1$ alone	$W_2$ reads zero
$>60^\circ$	$<0.5$	$W_1$	$W_2$ reads negative	$W_1+(-W_2)$	For taking readings, the PC or CC connection of $W_2$ should be reversed) (LPF case)

## SOLVED PROBLEMS

1. A 3-phase, 10 kVA load has a PF of 0.342. The power is measured by two wattmeter method. Find the reading of each wattmeter when the PF is (i) Lagging and (ii) Leading

Solution:

$$\text{The total VA, } S_{3ph} = \sqrt{3} V_L I_L$$

$$\text{i.e., } 10 \times 10^3 = \sqrt{3} V_L I_L$$

$$\text{Thus, } V_L I_L = 5.7735 \text{ kVA}$$

(i) **Lagging PF:**

$$W_1 = V_L I_L \cos(30-\phi) = 5.7735 \times 10^3 \cos(30-70) = 4.4228 \text{ kW and}$$

$$W_2 = V_L I_L \cos(30+\phi) = 5.7735 \times 10^3 \cos(30+70) = -1.0026 \text{ kW}$$

(ii) **Leading PF:**

$$W_1 = V_L I_L \cos(30+\phi) = -1.0026 \text{ kW and } W_2 = V_L I_L \cos(30-\phi) = 4.4228 \text{ kW}$$

**Note:** It can be observed that when the PF is changed from lagging to leading, the readings of wattmeters  $W_1$  and  $W_2$  get interchanged.

2. A 3-phase, 400 V load has a PF of 0.6 lagging. The two wattmeters read a total input power of 20 kW. Find reading of each wattmeter.

Solution:

$$W_1+W_2 = P_{3ph} = 20000 \text{ W, } V_L = 400 \text{ V, } \cos \phi = 0.6$$

$$\text{i.e., } 20 \times 10^3 = \sqrt{3} (400) I_L (0.6); \text{ solving, } I_L = 48.1125 \text{ A, } \phi = 53.13^\circ$$

$$W_1 = V_L I_L \cos(30-\phi) = 17.698 \text{ kW}$$

$$W_2 = V_L I_L \cos(30+\phi) = 2.302 \text{ kW}$$



**UNIT-4****LOCUS DIAGRAMS, RESONANCE AND MAGNETIC CIRCUITS**

- **Locus Diagrams with variation of various parameters**
- **Series RC and RL circuits**
- **Parallel RLC circuits**
- **Resonance**
- **Series and Parallel circuits**
- **Concept of Bandwidth and Quality factor**
- **Magnetic circuits**
- **Faradays Laws of Electromagnetic Induction**
- **Concepts of Self and Mutual Inductance**
- **Dot convention**
- **Coefficient of coupling**
- **Composite Magnetic circuits**
- **Analysis of Series and Parallel Magnetic circuits**
  - **Summary of important concepts and Formulae**
  - **Illustrative Examples**

## Locus Diagrams with variation of various parameters:

**Introduction:** In AC electrical circuits the magnitude and phase of the current vector depends upon the values of R,L&C when the applied voltage and frequency are kept constant. The path traced by the terminus (tip) of the current vector when the parameters R,L&C are varied is called the current **Locus diagram** . Locus diagrams are useful in studying and understanding the behavior of the RLC circuits when one of these parameters is varied keeping voltage and frequency constant.

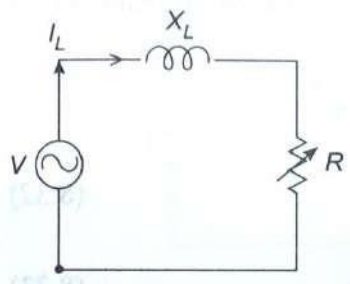
In this unit,Locus diagrams are developed and explained for series RC,RL circuits and Parallel LC circuits along with their internal resistances when the parameters R,L and C are varied.

The term circle diagram identifies locus plots that are either circular or semicircular. The defining equations of such circle diagrams are also derived in this unit for series RC and RL diagrams.

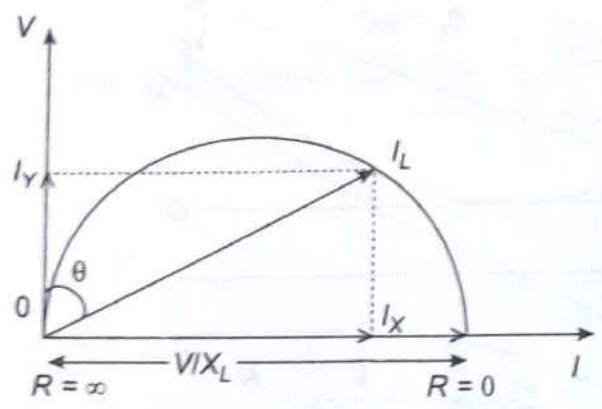
In both series RC,RL circuits and parallel LC circuits resistances are taken to be in series with L and C to highlight the fact that all practical L and C components will have at least a small value of internal resistance.

### Series RL circuit with varying Resistance R:

Refer to the series RL circuit shown in the figure (a) below with constant  $X_L$  and varying R. The current  $I_L$  lags behind the applied voltage V by a phase angle  $\theta = \tan^{-1}(X_L/R)$  for a given value of R as shown in the figure (b) below. When  $R=0$  we can see that the current is maximum equal to  $V/X_L$  and lies along the I axis with phase angle equal to  $90^\circ$ . When R is increased from zero to infinity the current gradually reduces from  $V/X_L$  to 0 and phase angle also reduces from  $90^\circ$  to  $0^\circ$ . As can be seen from the figure, the tip of the current vector traces the path of a semicircle with its diameter along the +ve I axis.



**Fig(a): Series RL circuit with Varying Resistance R**



**Fig(b): Locus of current vector  $I_L$  with variation of R**

The related equations are:

$$I_L = V/Z \quad \sin \theta = X_L/Z \text{ or } Z = X_L / \sin \theta \text{ and } \cos \theta = R / Z$$

Therefore  $I_L = (V/X_L) \sin \theta$

For constant  $V$  and  $X_L$  the above expression for  $I_L$  is the polar equation of a circle with diameter  $(V/X_L)$  as shown in the figure above.

*Circle equation for the RL circuit: (with fixed reactance and variable Resistance):*

The X and Y coordinates of the current  $I_L$  are

$$I_x = I_L \sin \theta \quad I_y = I_L \cos \theta$$

From the relations given above and earlier we get

$$I_x = (V/Z)(X_L/Z) = V X_L / Z^2 \quad \text{----- (1)}$$

and 
$$I_y = (V/Z)(R/Z) = V R / Z^2 \quad \text{----- (2)}$$

Squaring and adding the above two equations we get

$$I_x^2 + I_y^2 = V^2(X_L^2 + R^2) / Z^4 = (V^2 Z^2) / Z^4 = V^2 / Z^2 \quad \text{----- (3)}$$

From equation (1) above we have  $Z^2 = V X_L / I_x$  and substituting this in the above equation (3) we get :

$$I_x^2 + I_y^2 = V^2 / (V X_L / I_x) = (V/X_L) I_x \quad \text{or}$$

$$I_x^2 + I_y^2 - (V/X_L) I_x = 0$$

Adding  $(V/2X_L)^2$  to both sides ,the above equation can be written as

$$[I_x - V/2X_L]^2 + I_y^2 = (V/2X_L)^2 \quad \text{----- (4)}$$

Equation (4) above represents a circle with a radius of  $(V/2X_L)$  and with it's coordinates of the centre as  $(V/2X_L, 0)$

### Series RC circuit with varying Resistance R:

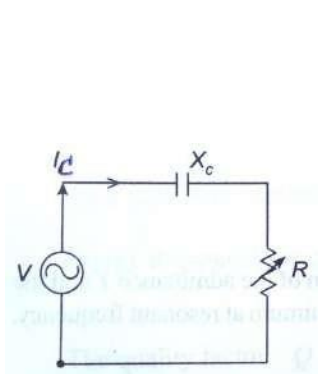
Refer to the series RC circuit shown in the figure (a) below with constant  $X_C$  and varying  $R$ . The current  $I_C$  leads the applied voltage  $V$  by a phase angle  $\theta = \tan^{-1}(X_C/R)$  for a given value of  $R$  as shown in the figure (b) below. When  $R=0$  we can see that the current is maximum equal to  $-V/X_C$  and lies along the negative I axis with phase angle equal to  $-90^\circ$ . When  $R$  is increased from zero to infinity the current gradually reduces from  $-V/X_C$  to 0 and phase angle also reduces from  $-90^\circ$  to  $0^\circ$ . As can be seen from the figure, the tip of the current vector traces the path of a semicircle but now with its diameter along the negative I axis.

*Circle equation for the RC circuit: (with fixed reactance and variable Resistance):*

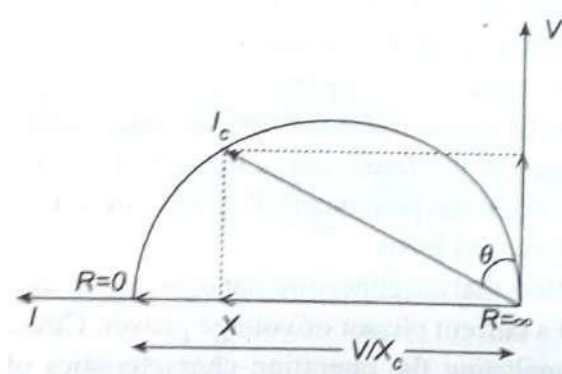
In the same way as we got for the Series RL circuit with varying resistance we can get the circle equation for an RC circuit with varying resistance as :

$$[I_x + V/2X_C]^2 + I_y^2 = (V/2X_C)^2$$

whose coordinates of the centre are  $(-V/2X_c, 0)$  and radius equal to  $V/2X_c$



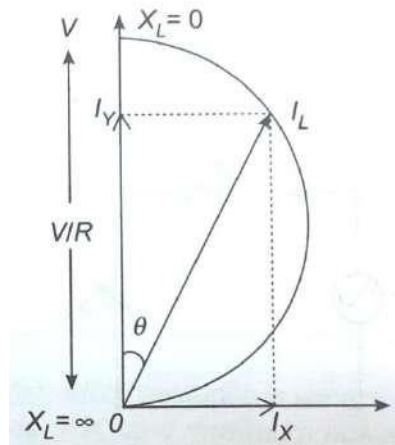
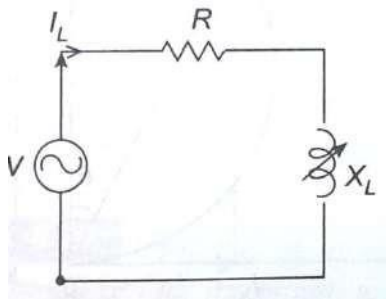
**Fig: Series RC circuit with Varying Resistance R**



**Fig: Locus of current vector  $I_c$  with variation of R**

**Series RL circuit with varying Reactance  $X_L$ :**

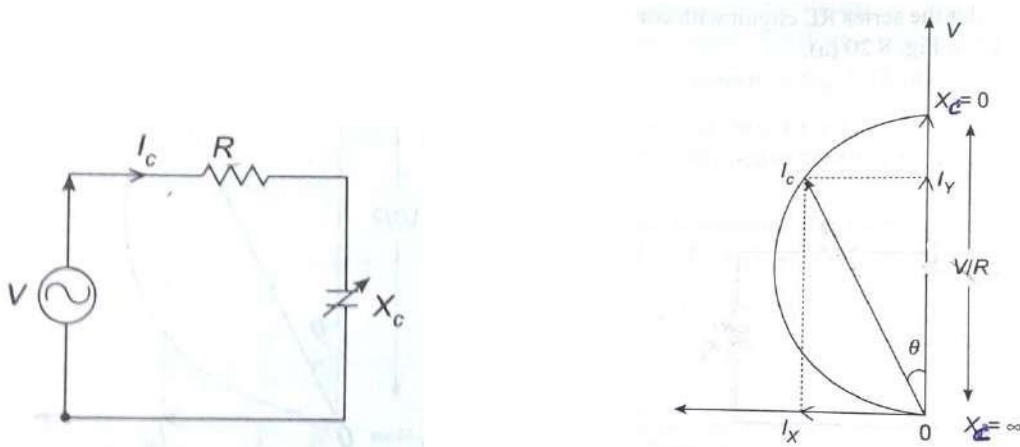
Refer to the series RL circuit shown in the figure (a) below with constant R and varying  $X_L$ . The current  $I_L$  lags behind the applied voltage V by a phase angle  $\theta = \tan^{-1}(X_L/R)$  for a given value of R as shown in the figure (b) below. When  $X_L = 0$  we can see that the current is maximum equal to  $V/R$  and lies along the +ve V axis with phase angle equal to  $0^\circ$ . When  $X_L$  is increased from zero to infinity the current gradually reduces from  $V/R$  to 0 and phase angle increases from  $0^\circ$  to  $90^\circ$ . As can be seen from the figure, the tip of the current vector traces the path of a semicircle with its diameter along the +ve V axis and on to its right side.



**Fig(a): Series RL circuit with varying  $X_L$  Fig(b) : Locus of current vector  $I_L$  with variation of  $X_L$**

**Series RC circuit with varying Reactance  $X_C$ :**

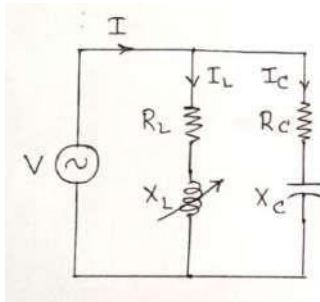
Refer to the series RC circuit shown in the figure (a) below with constant  $R$  and varying  $X_C$ . The current  $I_C$  leads the applied voltage  $V$  by a phase angle  $\theta = \tan^{-1}(X_C/R)$  for a given value of  $R$  as shown in the figure (b) below. When  $X_C = 0$  we can see that the current is maximum equal to  $V/R$  and lies along the  $V$  axis with phase angle equal to  $0^\circ$ . When  $X_C$  is increased from zero to infinity the current gradually reduces from  $V/R$  to  $0$  and phase angle increases from  $0^\circ$  to  $-90^\circ$ . As can be seen from the figure, the tip of the current vector traces the path of a semicircle with its diameter along the +ve  $V$  axis but now on to its left side.



**Fig(a): Series RC circuit with varying  $X_C$  Fig(b): Locus of current vector  $I_C$  with variation of  $X_C$**

**Parallel LC circuits:**

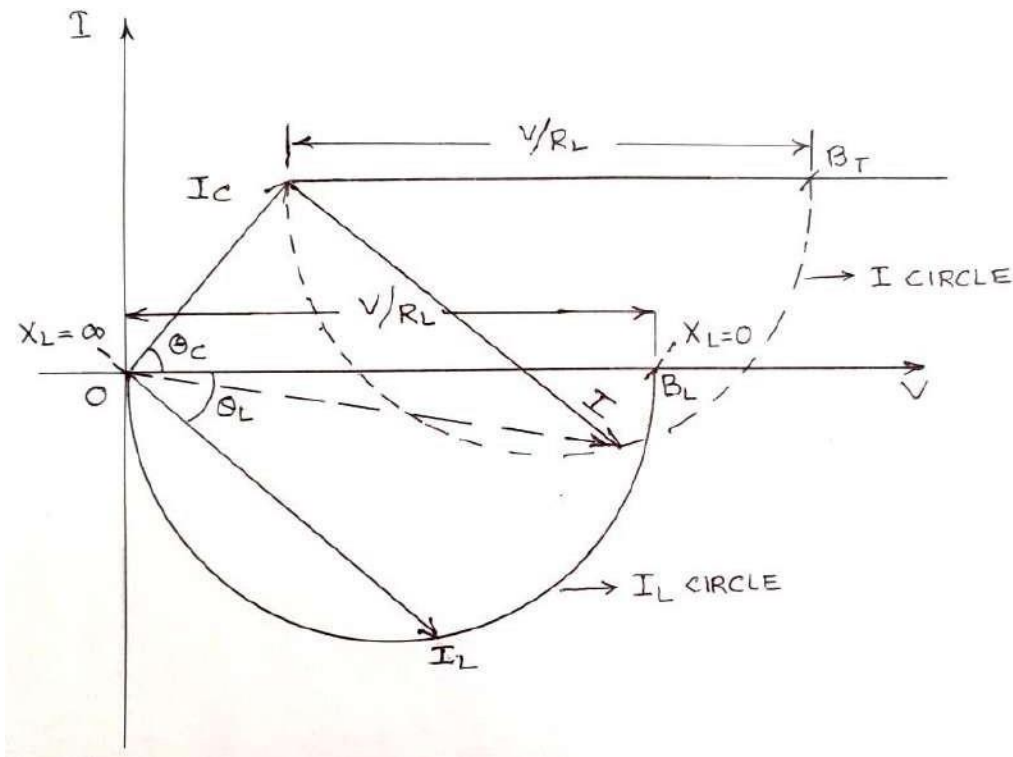
Parallel LC circuit along with its internal resistances as shown in the figures below is considered here for drawing the locus diagrams. As can be seen, there are two branch currents  $I_C$  and  $I_L$  along with the total current  $I$ . Locus diagrams of the current  $I_L$  or  $I_C$  (depending on which arm is varied) and the total current  $I$  are drawn by varying  $R_L, R_C, X_L$  and  $X_C$  one by one.

**Varying  $X_L$ :**

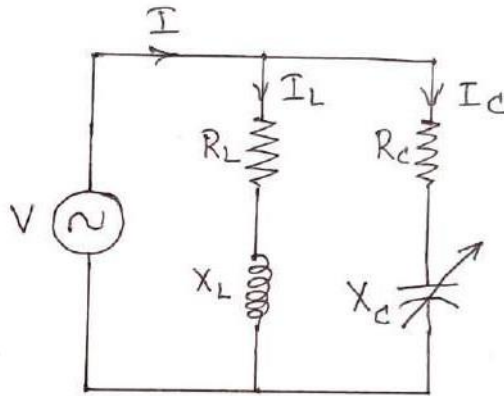
**Fig(a): parallel LC circuit with Internal Resistances  $R_L$  and  $R_C$  in series with  $L$  (Variable) and  $C$  (fixed) respectively.**

The current  $I_C$  through the capacitor is constant since  $R_C$  and  $C$  are fixed and it leads the voltage vector  $OV$  by an angle  $\theta_C = \tan^{-1}(X_C/R_C)$  as shown in the figure (b). The current  $I_L$  through the inductance is the vector  $OL$ . Its amplitude is maximum and equal to  $V/R_L$  when  $X_L$  is zero and it is in phase with the applied voltage  $V$ . When  $X_L$  is increased from zero to infinity its amplitude decreases to zero and phase will be lagging the voltage by  $90^\circ$ . In between, the phase angle will be lagging the voltage  $V$  by an angle  $\theta_L = \tan^{-1}(X_L/R_L)$ . The locus of the current vector  $I_L$  is a semicircle with a diameter of length equal to  $V/R_L$ . Note that this is the same locus what we got earlier for the series RL circuit with  $X_L$  varying except that here  $V$  is shown horizontally.

Now, to get the locus of the total current vector  $OI$  we have to add vectorially the currents  $I_C$  and  $I_L$ . We know that to get the sum of two vectors geometrically we have to place one of the vectors starting point (we will take varying amplitude vector  $I_L$ ) at the tip of the other vector (we will take constant amplitude vector  $I_C$ ) and then join the start of fixed vector  $I_C$  to the end of varying vector  $I_L$ . Using this principle we can get the locus of the total current vector  $OI$  by shifting the  $I_L$  semicircle starting point  $O$  to the end of current vector  $OI_C$  keeping the two diameters parallel. The resulting semicircle  $I_C I_B T$  shown in the figure in dotted lines is the locus of the total current vector  $OI$ .



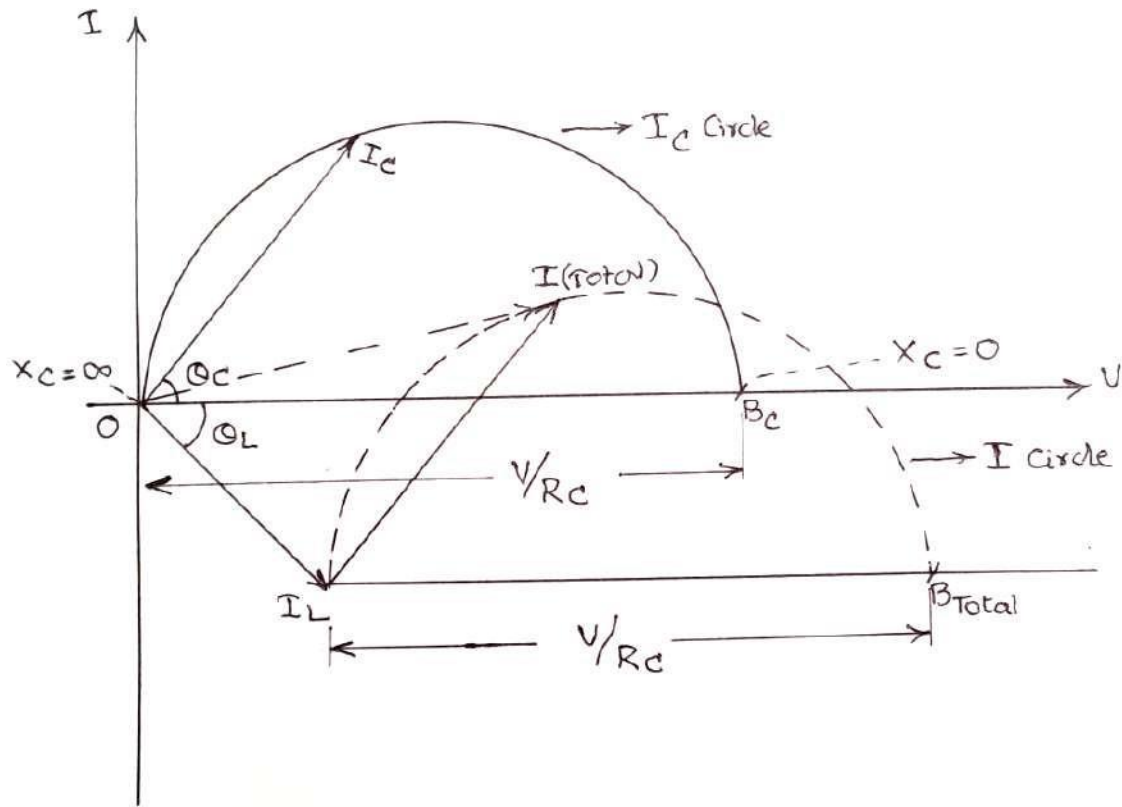
**Fig (b): Locus of current vector  $I$  in Parallel LC circuit when  $X_L$  is varied from 0 to  $\infty$**

**Varying  $X_C$ :**

**Fig.(a) parallel LC circuit with Internal Resistances  $R_L$  and  $R_C$  in series with  $L$  (fixed) and  $C$  (Variable) respectively.**

The current  $I_L$  through the inductor is constant since  $R_L$  and  $L$  are fixed and it lags the voltage vector  $OV$  by an angle  $\theta_L = \tan^{-1}(X_L/R_L)$  as shown in the figure (b). The current  $I_C$  through the capacitance is the vector  $OI_C$ . Its amplitude is maximum and equal to  $V/R_C$  when  $X_C$  is zero and it is in phase with the applied voltage  $V$ . When  $X_C$  is increased from zero to infinity its amplitude decreases to zero and phase will be leading the voltage by  $90^\circ$ . In between, the phase angle will be leading the voltage  $V$  by an angle  $\theta_C = \tan^{-1}(X_C/R_C)$ . The locus of the current vector  $I_C$  is a semicircle with a diameter of length equal to  $V/R_C$  as shown in the figure below. Note that this is the same locus what we got earlier for the series RC circuit with  $X_C$  varying except that here  $V$  is shown horizontally.

Now, to get the locus of the total current vector  $OI$  we have to add vectorially the currents  $I_C$  and  $I_L$ . We know that to get the sum of two vectors geometrically we have to place one of the vectors starting point (we will take varying amplitude vector  $I_C$ ) at the tip of the other vector (we will take constant amplitude vector  $I_L$ ) and then join the start of the fixed vector  $I_L$  to the end of varying vector  $I_C$ . Using this principle we can get the locus of the total current vector  $OI$  by shifting the  $I_C$  semicircle starting point  $O$  to the end of current vector  $OI_L$  keeping the two diameters parallel. The resulting semicircle  $I_L I_B T$  shown in the figure in dotted lines is the locus of the total current vector  $OI$ .

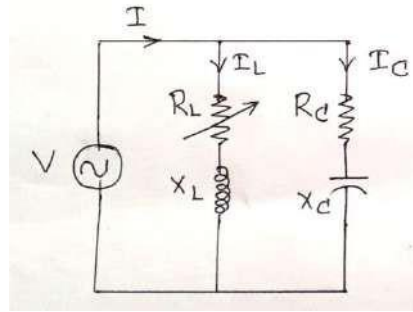


**Fig(b) : Locus of current vector  $I$  in Parallel LC circuit when  $X_c$  is varied from  $0$  to  $\infty$**

### **Varying $R_L$ :**

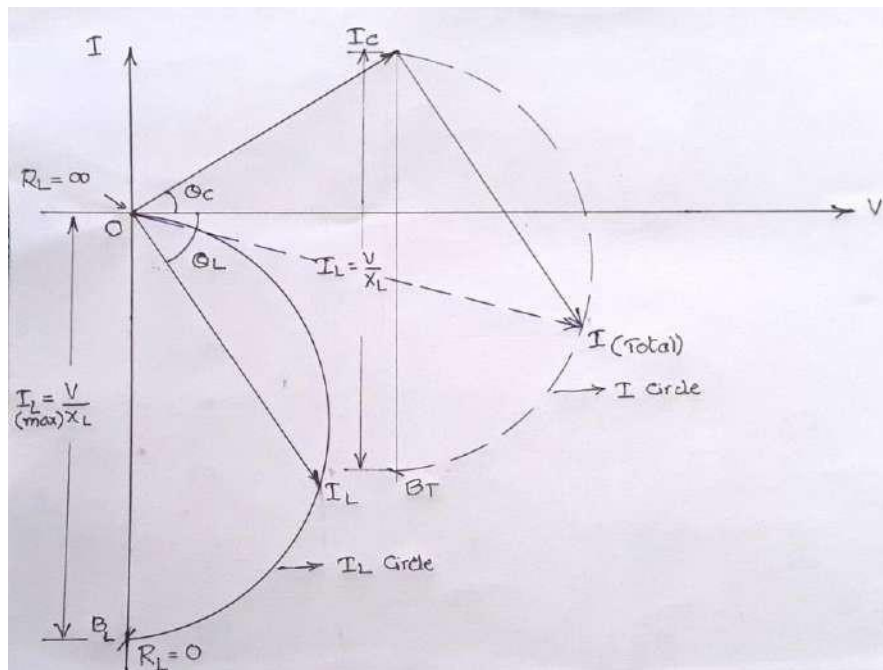
The current  $I_c$  through the capacitor is constant since  $R_c$  and  $C$  are fixed and it leads the voltage vector  $OV$  by an angle  $\theta_c = \tan^{-1}(X_c/R_c)$  as shown in the figure (b). The current  $I_L$  through the inductance is the vector  $OI_L$ . Its amplitude is maximum and equal to  $V/X_L$  when  $R_L$  is zero. Its phase will be lagging the voltage by  $90^\circ$ . When  $R_L$  is increased from zero to infinity its amplitude decreases to zero and it is in phase with the applied voltage  $V$ . In between, the phase angle will be lagging the voltage  $V$  by an angle  $\theta_L = \tan^{-1}(X_L/R_L)$ . The locus of the current vector  $I_L$  is a semicircle with a diameter of length equal to  $V/R_L$ . Note that this is the same locus what we got earlier for the series RL circuit with  $R$  varying except that here  $V$  is shown horizontally.



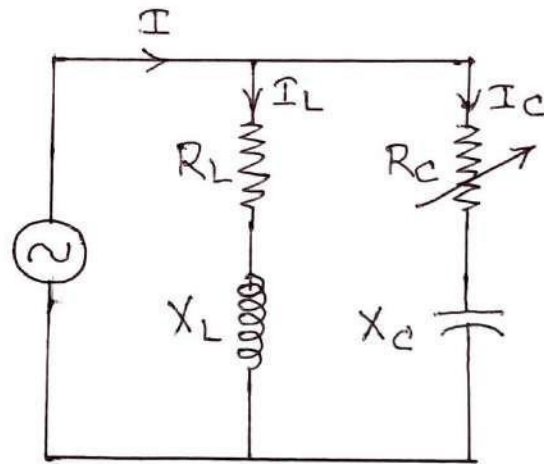


**Fig.(a) parallel LC circuit with Internal Resistances  $R_L$  (Variable) and  $R_C$  (fixed) in series with L and C respectively.**

Now, to get the locus of the total current vector  $OI$  we have to add vectorially the currents  $I_C$  and  $I_L$ . We know that to get the sum of two vectors geometrically we have to place one of the vectors starting point (we will take varying amplitude vector  $I_L$ ) at the tip of the other vector (we will take constant amplitude vector  $I_C$ ) and then join the start of fixed vector  $I_C$  to the end of varying vector  $I_L$ . Using this principle we can get the locus of the total current vector  $OI$  by shifting the  $I_L$  semicircle starting point  $O$  to the end of current vector  $OI_C$  keeping the two diameters parallel. The resulting semicircle  $I_CIB_T$  shown in the figure in dotted lines is the locus of the total current vector  $OI$ .



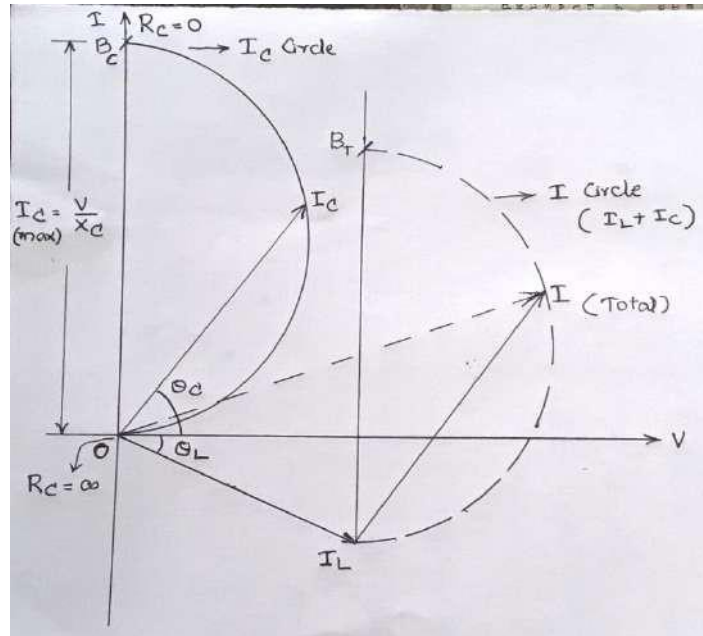
**Fig(b) : Locus of current vector  $I$  in Parallel LC circuit when  $R_L$  is varied from 0 to  $\infty$**

**Varying  $R_c$ :**

**Fig.(a) parallel LC circuit with Internal Resistances  $R_L$  (fixed) and  $R_c$  (Variable) in series with L and C respectively.**

The current  $I_L$  through the inductor is constant since  $R_L$  and  $L$  are fixed and it lags the voltage vector  $OV$  by an angle  $\Theta_L = \tan^{-1}(X_L/R_L)$  as shown in the figure (b). The current  $I_c$  through the capacitance is the vector  $OI_c$ . Its amplitude is maximum and equal to  $V/X_c$  when  $R_c$  is zero and its phase will be leading the voltage by  $90^\circ$ . When  $R_c$  is increased from zero to infinity its amplitude decreases to zero and it will be in phase with the applied voltage  $V$ . In between, the phase angle will be leading the voltage  $V$  by an angle  $\Theta_c = \tan^{-1}(X_c/R_c)$ . The locus of the current vector  $I_c$  is a semicircle with a diameter of length equal to  $V/X_c$  as shown in the figure below. Note that this is the same locus what we got earlier for the series RC circuit with  $R$  varying except that here  $V$  is shown horizontally.

Now, to get the locus of the total current vector  $OI$  we have to add vectorially the currents  $I_c$  and  $I_L$ . We know that to get the sum of two vectors geometrically we have to place one of the vectors starting point (we will take varying amplitude vector  $I_c$ ) at the tip of the other vector (we will take constant amplitude vector  $I_L$ ) and then join the start of the fixed vector  $I_L$  to the end of varying vector  $I_c$ . Using this principle we can get the locus of the total current vector  $OI$  by shifting the  $I_c$  semicircle starting point  $O$  to the end of current vector  $OI_L$  keeping the two diameters parallel. The resulting semicircle  $I_L I_B T$  shown in the figure in dotted lines is the locus of the total current vector  $OI$ .



Fig(b) : Locus of current vector I in Parallel LC circuit when Rc is varied from 0 to ∞

**Resonance :**

**Series RLC circuit:**

The impedance of the series RLC circuit shown in the figure below and the current I through the circuit are given by :

$$Z = R + j\omega L + 1/j\omega C = R + j(\omega L - 1/\omega C)$$

$$I = V_s/Z$$

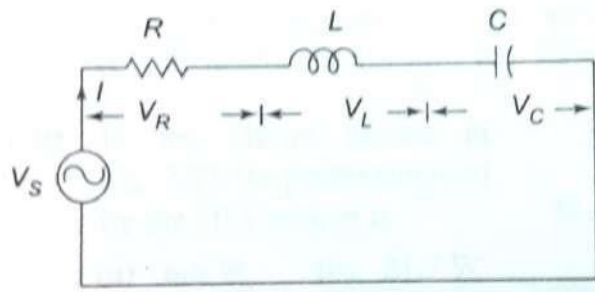


Fig: Series RLC circuit

The circuit is said to be in resonance when the Inductive reactance is equal to the Capacitive reactance. i.e.  $X_L = X_C$  or  $\omega L = 1/\omega C$ . (i.e. Imaginary of the impedance is zero) The frequency

at which the resonance occurs is called resonant frequency. In the resonant condition when  $X_L = X_C$  they cancel with each other since they are in phase opposition ( $180^\circ$  out of phase) and net impedance of the circuit is purely resistive. In this condition the magnitudes of voltages across the Capacitance and the Inductance are also equal to each other but again since they are of opposite polarity they cancel with each other and the entire applied voltage appears across the Resistance alone.

Solving for the resonant frequency from the above condition of Resonance :  $\omega L = 1/\omega C$

$$2\pi f_r L = 1/2\pi f_r C$$

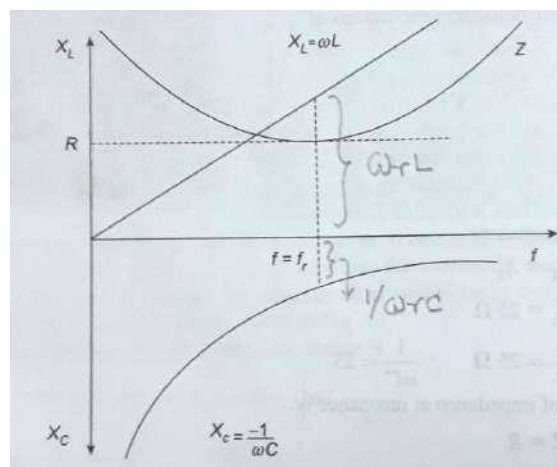
$$f_r^2 = 1/4\pi^2 LC \quad \text{and} \quad f_r = 1/2\pi\sqrt{LC}$$

In a series RLC circuit, resonance may be produced by varying L or C at a fixed frequency or by varying frequency at fixed L and C.

*Reactances, Impedance and Resistance of a Series RLC circuit as a function of frequency:*

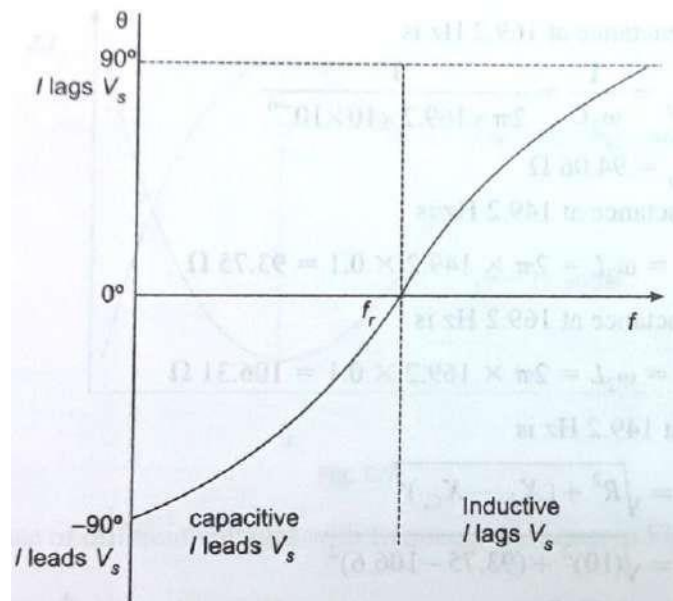
From the expressions for the Inductive and capacitive reactances we can see that when the frequency is zero, capacitance acts as an open circuit and Inductance as a short circuit. Similarly when the frequency is infinity inductance acts as an open circuit and the capacitance acts as a short circuit. The variation of Inductive and capacitive reactances along with Resistance R and the Total Impedance are shown plotted in the figure below.

As can be seen, when the frequency increases from zero to  $\infty$  Inductive reactance  $X_L$  (directly proportional to  $\omega$ ) increases from zero to  $\infty$  and Capacitive reactance  $X_C$  (inversely proportional to  $\omega$ ) decreases from  $-\infty$  to zero. Whereas, the Impedance decreases from  $\infty$  to Pure Resistance R as the frequency increases from zero to  $f_r$  ( as capacitive reactance reduces from  $-\infty$  and becomes equal to Inductive reactance ) and then increases from R to  $\infty$  as the frequency increases from  $f_r$  to  $\infty$  ( as inductive reactance increases from its value at resonant frequency to  $\infty$  )



**Fig : Reactance and Impedance plots of a Series RLC circuit**

*Phase angle of a Series RLC circuit as a function of frequency:*



**Fig : Phase plot of a Series RLC circuit**

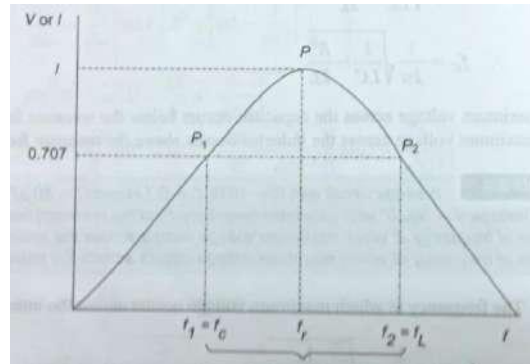
The following points can be seen from the Phase angle plot shown in the figure above:

- At frequencies below the resonant frequency capacitive reactance is higher than the inductive reactance and hence the phase angle of the current leads the voltage.
- As frequency increases from zero to  $f_r$  the phase angle changes from  $-90^\circ$  to zero.
- At frequencies above the resonant frequency inductive reactance is higher than the capacitive reactance and hence the phase angle of the current lags the voltage.
- As frequency increases from  $f_r$  and approaches  $\infty$ , the phase angle increases from zero and approaches  $90^\circ$

#### **Band width of a Series RLC circuit:**

The band width of a circuit is defined as the Range of frequencies between which the output power is half of or 3 db less than the output power at the resonant frequency. These frequencies are called the cutoff frequencies, 3db points or half power points. But when we consider the output voltage or current, the range of frequencies between which the output voltage or current falls to 0.707 times of the value at the resonant frequency is called the Bandwidth BW. This is because voltage/current are related to power by a factor of  $\sqrt{2}$  and when we are consider  $\sqrt{2}$  times less it becomes 0.707. But still these frequencies are called

as cutoff frequencies, 3db points or half power points. The lower end frequency is called **lower cutoff frequency** and the higher end frequency is called upper **cutoff frequency**.



**Fig: Plot showing the cutoff frequencies and Bandwidth of a series RLC circuit**

*Derivation of an expression for the BW of a series RLC circuit:*

We know that  $BW = f_2 - f_1$  Hz

If the current at points  $P_1$  and  $P_2$  are  $0.707 (1/\sqrt{2})$  times that of  $I_{max}$  (current at the resonant frequency) then the Impedance of the circuit at points  $P_1$  and  $P_2$  is  $\sqrt{2} R$  (i.e.  $\sqrt{2}$  times the impedance at  $f_r$ )

But Impedance at point  $P_1$  is given by:  $Z = \sqrt{R^2 + (1/\omega_1 C - \omega_1 L)^2}$  and equating this to  $\sqrt{2} R$  we get :

$$(1/\omega_1 C) - \omega_1 L = R \quad \text{----- (1)}$$

Similarly Impedance at point  $P_2$  is given by:  $Z = \sqrt{R^2 + (\omega_2 L - 1/\omega_2 C)^2}$  and equating this to  $\sqrt{2} R$  we get:

$$\omega_2 L - (1/\omega_2 C) = R \quad \text{----- (2)}$$

Equating the above equations (1) and (2) we get:

$$1/\omega_1 C - \omega_1 L = \omega_2 L - 1/\omega_2 C$$

Rearranging we get  $L(\omega_1 + \omega_2) = 1/C [(1/\omega_1 + 1/\omega_2)]$  i.e.  $\omega_1 \omega_2 = 1/LC$

But we already know that for a series RLC circuit the resonant frequency is given by  $\omega_r^2 = 1/LC$   
Therefore:  $\omega_1 \omega_2 = \omega_r^2$  ---- (3) and  $1/C = \omega_r^2 L$  ----- (4)

Next adding the above equations (1) and (2) we get:

$$\begin{aligned} 1/\omega_1 C - \omega_1 L + \omega_2 L - 1/\omega_2 C &= 2R \\ (\omega_2 - \omega_1)L + (1/\omega_1 C - 1/\omega_2 C) &= 2R \\ (\omega_2 - \omega_1)L + 1/C[(\omega_2 - \omega_1)/\omega_1 \omega_2] &= 2R \quad \text{----- (5)} \end{aligned}$$

Using the values of  $\omega_1 \omega_2$  and  $1/C$  from equations (3) and (4) above into equation (5) above we get:

$$\text{i.e. } 2L(\omega_2 - \omega_1) = 2R \quad \text{i.e. } (\omega_2 - \omega_1) = R/L \quad \text{and } (f_2 - f_1) = R/2\pi L \text{----- (6)}$$

$$\text{Or finally Band width} \quad \mathbf{BW = R/2\pi L} \text{----- (7)}$$

Since  $f_r$  lies in the centre of the lower and upper cutoff frequencies  $f_1$  and  $f_2$  using the above equation (6) we can get:

$$f_1 = f_r - R/4\pi L \quad \text{-----} \quad (8)$$

$$f_2 = f_r + R/4\pi L \quad \text{-----} \quad (9)$$

Further by dividing the equation (6) above by  $f_r$  on both sides we get another **important** relation :

$$(f_2 - f_1) / f_r = R/2\pi f_r L \quad \text{or} \quad BW / f_r = R/2\pi f_r L \quad \text{-----} \quad (10)$$

Here an important property of a coil i.e. **Q factor** or **figure of merit** is defined as the ratio of the reactance to the resistance of a coil.

$$Q = 2\pi f_r L / R \quad \text{-----} \quad (11)$$

Now using the relation (11) we can rewrite the relation (10) as

$$Q = f_r / BW \quad \text{-----} \quad (12)$$

### Quality factor of a series RLC circuit:

The quality factor of a series RLC circuit is defined as:

**Q = Reactive power in Inductor (or Capacitor) at resonance / Average power at Resonance**

Reactive power in Inductor at resonance =  $I^2 X_L$

Reactive power in Capacitor at resonance =  $I^2 X_C$

Average power at Resonance =  $I^2 R$

Here the power is expressed in the form  $I^2 X$  (not as  $V^2/X$ ) since  $I$  is common through R,L and C in the series RLC circuit and it gets cancelled during the simplification.

Therefore  $Q = I^2 X_L / I^2 R = I^2 X_C / I^2 R$

i.e.  $Q = X_L / R = \omega_r L / R \quad \text{-----} \quad (1)$

Or  $Q = X_C / R = 1/\omega_r RC \quad \text{-----} \quad (2)$

From these two relations we can also define Q factor as :

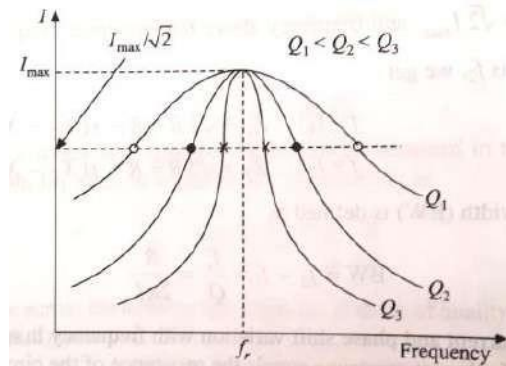
**Q = Inductive (or Capacitive) reactance at resonance / Resistance**

Substituting the value of  $\omega_r = 1/\sqrt{LC}$  in the expressions (1) or (2) for **Q** above we can get the value of **Q** in terms of **R, L, C** as below.

$$Q = (1/\sqrt{LC}) L / R = (1/R) (\sqrt{L/C})$$

### Selectivity:

Selectivity of a series **RLC** circuit indicates how well the given circuit responds to a given resonant frequency and how well it rejects all other frequencies. i.e. the selectivity is directly proportional to **Q** factor. A circuit with a good selectivity (or a high **Q** factor) will have maximum gain at the resonant frequency and will have minimum gain at other frequencies .i.e. it will have very low band width. This is illustrated in the figure below.



**Fig: Effect of quality factor on bandwidth Voltage Magnification at resonance:**

At resonance the voltages across the Inductance and capacitance are much larger than the applied voltage in a series RLC circuit and this is called voltage magnification at Resonance. The voltage magnification is equal to the **Q** factor of the circuit. This is proven below.

If we take the voltage applied to the circuit as **V** and the current through the circuit at resonance as **I** then

The voltage across the inductance **L** is:  $V_L = IX_L = (V/R) \omega_r L$  and

The voltage across the capacitance **C** is:  $V_C = IX_C = V/R \omega_r C$

But we know that the **Q** of a series RLC circuit =  $\omega_r L / R = 1/R \omega_r C$

Using these relations in the expressions for  $V_L$  and  $V_C$  given above we get

$V_L = VQ$  and  $V_C = VQ$

The ratio of voltage across the Inductor or capacitor at resonance to the applied voltage in a series RLC circuit is called Voltage magnification and is given by

$$\text{Magnification} = Q = V_L/V \text{ or } V_C/V$$

#### **Important points In Series RLC circuit at resonant frequency :**

- The impedance of the circuit becomes purely resistive and minimum i.e  $Z = R$
- The current in the circuit becomes maximum
- The magnitudes of the capacitive Reactance and Inductive Reactance become equal
- The voltage across the Capacitor becomes equal to the voltage across the Inductor at resonance and is **Q** times higher than the voltage across the resistor

#### **Bandwidth and Q factor of a Parallel RLC circuit:**

Parallel RLC circuit is shown in the figure below. For finding out the **BW** and **Q** factor of a parallel RLC circuit, since it is easier we will work with Admittance, Conductance and Susceptance instead of Impedance, Resistance and Reactance like in series RLC circuit.



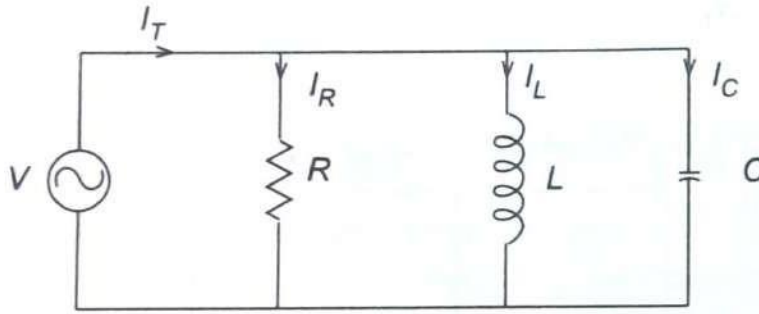


Fig: Parallel RLC circuit

Then we have the relation:  $Y = 1/Z = 1/R + 1/j\omega L + j\omega C = 1/R + j(\omega C - 1/\omega L)$

For the parallel RLC circuit also, at resonance, the imaginary part of the Admittance is zero and hence the frequency at which resonance occurs is given by:  $\omega_r C - 1/\omega_r L = 0$ . From this

we get :  $\omega_r C = 1/\omega_r L$  and  $\omega_r = 1/\sqrt{LC}$   
 which is the same value for  $\omega_r$  as what we got for the series RLC circuit.

At resonance when the imaginary part of the admittance is zero the **admittance** becomes **minimum**. ( i.e **Impedance** becomes **maximum** as against Impedance becoming minimum in series RLC circuit ) i.e. Current becomes minimum in the parallel RLC circuit at resonance ( as against current becoming maximum in series RLC circuit) and increases on either side of the resonant frequency as shown in the figure below.

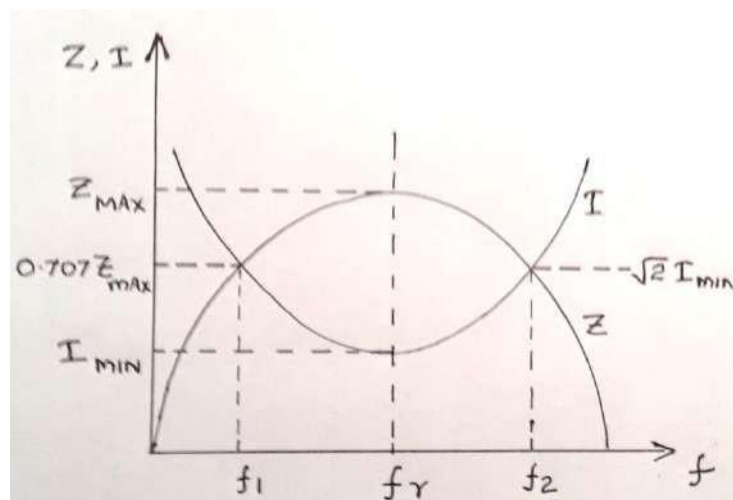


Fig: Variation of Impedance and Current with frequency in a Parallel RLC circuit

Here also the BW of the circuit is given by  $BW = f_2 - f_1$  where  $f_2$  and  $f_1$  are still called the upper and lower cut off frequencies but they are 3db higher cutoff frequencies since we notice that at these cutoff frequencies the amplitude of the current is  $\sqrt{2}$  times higher than that of the amplitude of current at the resonant frequency.

The BW is computed here also on the same lines as we did for the series RLC circuit:

If the current at points  $P_1$  and  $P_2$  is  $\sqrt{2}$  (3db) times higher than that of  $I_{min}$  (current at the resonant frequency) then the admittance of the circuit at points  $P_1$  and  $P_2$  is also  $\sqrt{2}$  times higher than the admittance at  $f_r$  )

But amplitude of admittance at point  $P_1$  is given by:  $Y = \sqrt{1/R^2 + (1/\omega_1 L - \omega_1 C)^2}$  and equating this to  $\sqrt{2}/R$  we get

$$1/\omega_1 L - \omega_1 C = 1/R \text{----- (1)}$$

Similarly amplitude of admittance at point  $P_2$  is given by:  $Y = \sqrt{1/R^2 + (\omega_2 C - 1/\omega_2 L)^2}$  and equating this to  $\sqrt{2}/R$  we get

$$\omega_2 C - 1/\omega_2 L = 1/R \text{----- (2)}$$

Equating LHS of (1) and (2) and further simplifying we get

$$1/\omega_1 L - \omega_1 C = \omega_2 C - 1/\omega_2 L$$

$$1/\omega_1 L + 1/\omega_2 L = \omega_1 C + \omega_2 C$$

$$1/L [(\omega_1 + \omega_2)/\omega_1 \omega_2] = (\omega_1 + \omega_2)C$$

$$1/LC = \omega_1 \omega_2$$

Next adding the equations (1) and (2) above and further simplifying we get

$$1/\omega_1 L - \omega_1 C + \omega_2 C - 1/\omega_2 L = 2/R$$

$$(\omega_2 C - \omega_1 C) + (1/\omega_1 L - 1/\omega_2 L) = 2/R$$

$$(\omega_2 - \omega_1)C + 1/L [(\omega_2 - \omega_1)/\omega_1 \omega_2] = 2/R$$

Substituting the value of  $\omega_1 \omega_2 = 1/LC$

$$(\omega_2 - \omega_1)C + LC/L [(\omega_2 - \omega_1)] = 2/R$$

$$(\omega_2 - \omega_1)C + C [(\omega_2 - \omega_1)] = 2/R$$

$$2C [(\omega_2 - \omega_1)] = 2/R$$

$$\text{Or } [(\omega_2 - \omega_1)] = 1/RC$$

From which we get the band width  $BW = f_2 - f_1 = 1/2\pi RC$

Dividing both sides by  $f_r$  we get :  $(f_2 - f_1)/f_r = 1/2\pi f_r RC \text{----- (1)}$

**Quality factor of a Parallel RLC circuit:**

The quality factor of a Parallel RLC circuit is defined as:

**Q = Reactive power in Inductor (or Capacitor) at resonance / Average power at Resonance**

$$\text{Reactive power in Inductor at resonance} = V^2/X_L$$

$$\text{Reactive power in Capacitor at resonance} = V^2/X_C$$

$$\text{Average power at Resonance} = V^2/R$$

Here the power is expressed in the form  $V^2/X$  (not as  $I^2X$  as in series circuit) since  $V$  is common across  $R, L$  and  $C$  in the parallel RLC circuit and it gets cancelled during the simplification.

$$\text{Therefore } Q = (V^2/X_L) / (V^2/R) = (V^2/X_C) / (V^2/R)$$

i.e.  $Q = R/X_L = R/\omega_r L$ ----- (1)

Or  $Q = R/X_C = \omega_r RC$ ----- (2)

From these two relations we can also define **Q** factor as :

**Q = Resistance /Inductive (or Capacitive ) reactance at resonance**

Substituting the value of  $\omega_r = 1/\sqrt{LC}$  in the expressions (1) or (2) for **Q** above we can get the value of **Q** in terms of R, L,C as below.

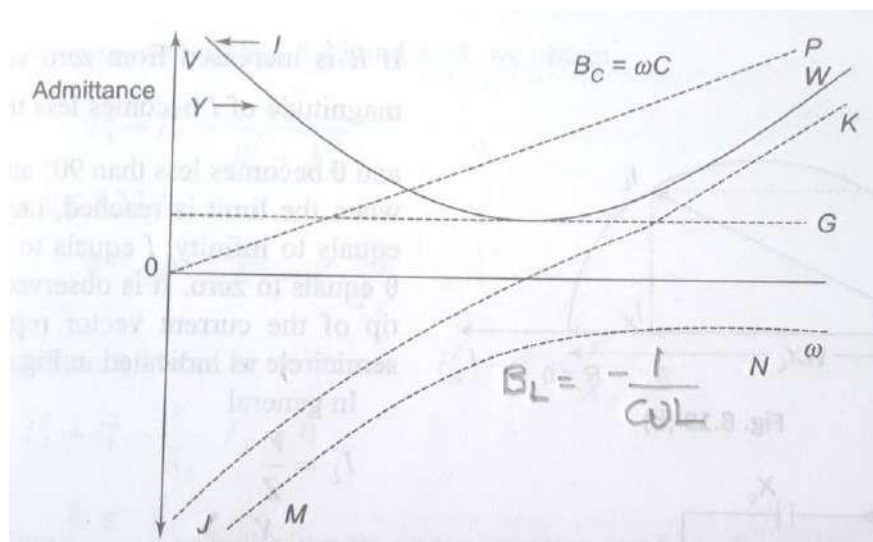
$$Q = (1/\sqrt{LC}) RC = R(\sqrt{C/L})$$

Further using the relation  $Q = \omega_r RC$  ( equation 2 above ) in the earlier equation (1) we got in BW viz.  $(f_2-f_1)/f_r = 1/2\pi f_r RC$  we get :  $(f_2-f_1)/f_r = 1/Q$  or  $Q = f_r / (f_2-f_1) = f_r / BW$

i.e. In Parallel RLC circuit also the Q factor is inversely proportional to the BW.

**Admittance, Conductance and Susceptance curves for a Parallel RLC circuit as a function of frequency :**

- The effect of varying the frequency on the Admittance, Conductance and Susceptance of a parallel circuit is shown in the figure below.
- Inductive susceptance  $B_L$  is given by  $B_L = -1/\omega L$ . It is inversely proportional to the frequency  $\omega$  and is shown in the in the fourth quadrant since it is negative.
- Capacitive susceptance  $B_C$  is given by  $B_C = \omega C$ . It is directly proportional to the frequency  $\omega$  and is shown in the in the first quadrant as OP .It is positive and linear.
- Net susceptance  $B = B_C - B_L$  and is represented by the curve JK. As can be seen it is zero at the resonant frequency  $f_r$
- The conductance  $G = 1/R$  and is constant
- The total admittance **Y** and the total current **I** are minimum at the resonant frequency as shown by the curve **VW**



**Fig: Conductance,Susceptance and Admittance plots of a Parallel RLC circuit**

**Current magnification in a Parallel RLC circuit:**

Just as voltage magnification takes place across the capacitance and Inductance at the resonant frequency in a series RLC circuit, current magnification takes place in the currents through the capacitance and Inductance at the resonant frequency in a Parallel RLC circuit. This is shown below.

Voltage across the Resistance =  $V = IR$

Current through the Inductance at resonance  $I_L = V / \omega_r L = IR / \omega_r L = I \cdot R / \omega_r L = IQ$

**Similarly**

Current through the Capacitance at resonance  $I_C = V / (1/\omega_r C) = IR / (1/\omega_r C) = I(R \omega_r C) = IQ$

From which we notice that the quality factor  $Q = I_L / I$  or  $I_C / I$  and that the current through the inductance and the capacitance increases by  $Q$  times that of the current through the resistor at resonance.

**Important points In Parallel RLC circuit at resonant frequency :**

- The impedance of the circuit becomes resistive and maximum i.e  $Z = R$
- The current in the circuit becomes minimum
- The magnitudes of the capacitive Reactance and Inductive Reactance become equal
- The current through the Capacitor becomes equal and opposite to the current through the Inductor at resonance and is  $Q$  times higher than the current through the resistor

**Magnetic Circuits:****Introduction to the Magnetic Field:**

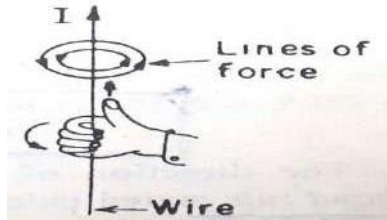
Magnetic fields are the fundamental medium through which energy is converted from one form to another in motors, generators and transformers. Four basic principles describe how magnetic fields are used in these devices.

1. A current-carrying conductor produces a magnetic field in the area around it.  
*Explained in Detail by Fleming's Right hand rule and Amperes Law.*
2. A time varying magnetic flux induces a voltage in a coil of wire if it passes through that coil.  
(basis of Transformer action)  
*Explained in detail by the Faradays laws of Electromagnetic Induction.*
3. A current carrying conductor in the presence of a magnetic field has a force induced in it  
(Basis of Motor action)
4. A moving wire in the presence of a magnetic field has a voltage induced in it (Basis of Generator action)

We will be studying in this unit the first two principles in detail and the other two principles in the next unit on DC machines.

**Two basic laws governing the production of a magnetic field by a current carrying conductor :**  
The direction of the magnetic field produced by a current carrying conductor is given by the **Flemings Right hand rule** and its' amplitude is given by the **Ampere's Law**.

**Flemings right hand rule:** Hold the conductor carrying the current in your right hand such that the Thumb points along the wire in the direction of the flow of current, then the fingers will encircle the wire along the lines of the Magnetic force.



**Ampere's Law :** The line integral of the magnetic field intensity  $H$  around a closed magnetic path is equal to the total current enclosed by the path.

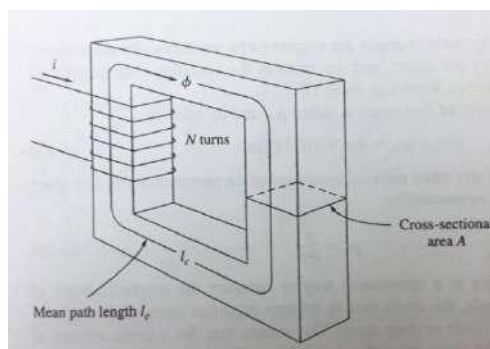
This is the basic law which gives the relationship between the Magnetic field Intensity  $H$  and the current  $I$  and is mathematically expressed as

$$\oint \mathbf{H} \cdot d\mathbf{l} = I_{net}$$

where  $\mathbf{H}$  is the magnetic field intensity produced by the current  $I_{net}$  and  $d\mathbf{l}$  is a differential element of length along the path of integration.  $\mathbf{H}$  is measured in *Ampere-turns per meter*.

**Important parameters and their relation in magnetic circuits :**

- Consider a current carrying conductor wrapped around a ferromagnetic core as shown in the figure below .



- Applying Ampere's law, the total amount of magnetic field induced will be proportional to the amount of current flowing through the conductor wound with  $N$  turns around the ferromagnetic material as shown. Since the core is made of ferromagnetic material, it is assumed that a majority of the magnetic field will be confined to the core.

- The path of integration in this case as per the Ampere's law is the mean path length of the core,  $l_c$ . The current passing within the path of integration  $I_{net}$  is then  $Ni$ , since the coil of wire cuts the path of integration  $N$  times while carrying the current  $i$ . Hence Ampere's Law becomes :

$$Hl_c = Ni$$

Therefore

$$H = Ni/l_c$$

- In this sense,  $H$  (Ampere turns per meter) is known as the effort required to induce a magnetic field. The strength of the magnetic field flux produced in the core also depends on the material of the core. Thus:  $B = \mu H$  where  
 $B$  = magnetic flux density [webers per square meter, or Tesla (T)]  
 $\mu$  = magnetic permeability of material (Henrys per meter)  
 $H$  = magnetic field intensity (ampere-turns per meter)
- The constant  $\mu$  may be further expanded to include **relative permeability** which can be defined as below:  
 $\mu_r = \mu / \mu_0$   
 where  $\mu_0$  = permeability of free space (equal to that of air)
- Hence the permeability value is a combination of the relative permeability and the permeability of free space. The value of relative permeability is dependent upon the type of material used. The higher the amount permeability, the higher the amount of flux induced in the core. Relative permeability is a convenient way to compare the magnetizability of materials.
- Also, because the permeability of iron is so much higher than that of air, the majority of the flux in an iron core remains inside the core instead of travelling through the surrounding air, which has lower permeability. The small leakage flux that does leave the iron core is important in determining the flux linkages between coils and the self-inductances of coils in transformers and motors.
- In a core such as shown in the figure above

$$B = \mu H = \mu Ni/l_c$$

Now, to measure the total flux flowing in the ferromagnetic core, consideration has to be made in terms of its cross sectional area (CSA). Therefore:

$$\Phi = \int B \cdot dA \text{ where: } A = \text{cross sectional area throughout the core.}$$

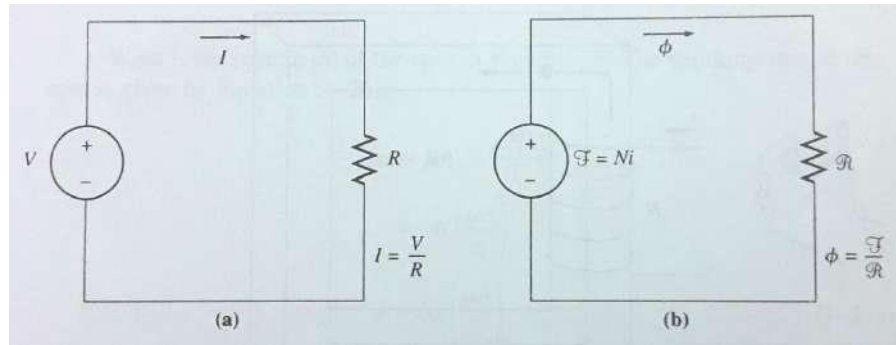
Assuming that the flux density in the ferromagnetic core is constant throughout hence the equation simplifies to:  $\Phi = B \cdot A$

Taking the previous expression for  $B$  we get  $\Phi = \mu NiA/l_c$

**Electrical analogy of magnetic circuits:**

The flow of magnetic flux induced in the ferromagnetic core is analogous to the flow of electric current in an electrical circuit hence the name magnetic circuit.

The analogy is as follows:

**(a) Electric Circuit****(b) Electrical Analogy of Magnetic Circuit**

- Referring to the magnetic circuit analogy,  $F$  is denoted as **magnetomotive force** (mmf) which is similar to Electromotive force in an electrical circuit (emf). Therefore, we can say that  $F$  is the force which pushes magnetic flux around a ferromagnetic core with a value of  $Ni$  (refer to ampere's law). Hence  $F$  is measured in ampere turns. Hence the magnetic circuit equivalent equation is as shown:

$$F = \Phi \cdot R \text{ (similar to } V=IR)$$

We already have the relation  $\Phi = \mu NiA/l$  and using this we get  $R = F / \Phi = Ni / \Phi$

$$R = Ni / (\mu NiA/l) = l / \mu A$$

- The polarity of the mmf will determine the direction of flux. To easily determine the direction of flux, the '**right hand curl**' rule is applied:  
**When the direction of the curled fingers indicates the direction of current flow the resulting thumb direction will show the magnetic flux flow.**
- The element of  $R$  in the magnetic circuit analogy is similar in concept to the electrical resistance. It is basically the measure of material resistance to the flow of magnetic flux. **Reluctance** in this analogy obeys the rule of electrical resistance (Series and Parallel Rules). Reluctance is measured in **Ampere-turns per weber**.
- The inverse of electrical resistance is conductance which is a measure of conductivity of a material. Similarly the inverse of reluctance is known as **permeance P** which represents the degree to which the material permits the flow of magnetic flux.
- By using the magnetic circuit approach, calculations related to the magnetic field in a ferromagnetic material are simplified but with a little inaccuracy.

**Equivalent Reluctance of a series Magnetic circuit :**  $R_{eqseries} = R_1 + R_2 + R_3 + \dots$

**Equivalent Reluctance of a Parallel Magnetic circuit:**  $1/R_{eqparallel} = 1/R_1 + 1/R_2 + 1/R_3 + \dots$

### Electromagnetic Induction and Faraday's law – Induced Voltage from a Time-Changing Magnetic Field:

#### Faraday's Law:

*Whenever a varying magnetic flux passes through a turn of a coil of wire, voltage will be induced in the turn of the wire that is directly proportional to the rate of change of the flux linkage with the turn of the coil of wire.*

$$e_{ind} \propto -d\Phi/dt$$

$$e_{ind} = -k \cdot d\Phi/dt$$

The negative sign in the equation above is in accordance to **Lenz' Law** which states:

*The direction of the induced voltage in the turn of the coil is such that if the coil is short circuited, it would produce a current that would cause a flux which opposes the original change of flux.*

And **k** is the constant of proportionality whose value depends on the system of units chosen. In the SI system of units **k=1** and the above equation becomes:

$$e_{ind} = -d\Phi/dt$$

Normally a coil is used with several turns and if there are N number of turns in the coil with the same amount of flux flowing through it then:

$$e_{ind} = -N d\Phi/dt$$

*Change in the flux linkage  $N\Phi$  of a coil can be obtained in two ways:*

1. Coil remains stationary and flux changes with time (Due to AC current like in Transformers and this is called Statically induced e.m.f )
2. Magnetic flux remains constant and stationary in space, but the coil moves relative to the magnetic field so as to create a change in the flux linkage of the coil ( Like in Rotating machines and this is a called Dynamically induced e.m.f.

#### Self inductance:

From the Faradays laws of Electromagnetic Induction we have seen that an e.m.f will be induced in a conductor when a time varying flux is linked with a conductor and the amplitude of the induced e.m.f is proportional to the rate of change of the varying flux.

If the time varying flux is produced by a coil of **N** turns then the coil itself links with the time varying flux produced by itself and an emf will be induced in the same coil. This is called self inductance .

The flux  $\Phi$  produced by a coil of N turns links with its own N turns of the coil and hence the total flux linkage is equal to  $N\Phi = (\mu N^2 A / l) I$  [using the expression  $\Phi = \mu NiA/l$  we already



developed] Thus we see that the total magnetic flux produced by a coil of  $N$  turns and linked with itself is proportional to the current flowing through the coil i.e.

$$N\Phi \propto I \text{ or } N\Phi = LI$$

From the Faradays law of electromagnetic Induction, the self induced e.m.f for this coil of  $N$  turns is given by:

$$e_{\text{ind}} = -N \frac{d\Phi}{dt} = -L \frac{di}{dt}$$

The constant of proportionality  $L$  is called the self Inductance of the coil or simply Inductance and its value is given by  $L = (\mu N^2 A / l)$ . If the radius of the coil is  $r$  then:

$$L = (\mu N^2 \pi r^2 / l) i$$

From the above two equations we can see that Self Inductance of a coil can be defined as the flux produced per unit current i.e *Weber/Ampere* (equation1) or the induced emf per unit rate of change of current i.e *Volt-sec/Ampere* (equation 2 )

The unit of Inductance is named after Joseph Henry as **Henry** and is given to these two combinations as :

$$1H = 1WbA^{-1} = 1VsA^{-1}$$

*Self Inductance of a coil is defined as one Henry if an induced emf of one volt is generated when the current in the coil changes at the rate of one Ampere per second.*

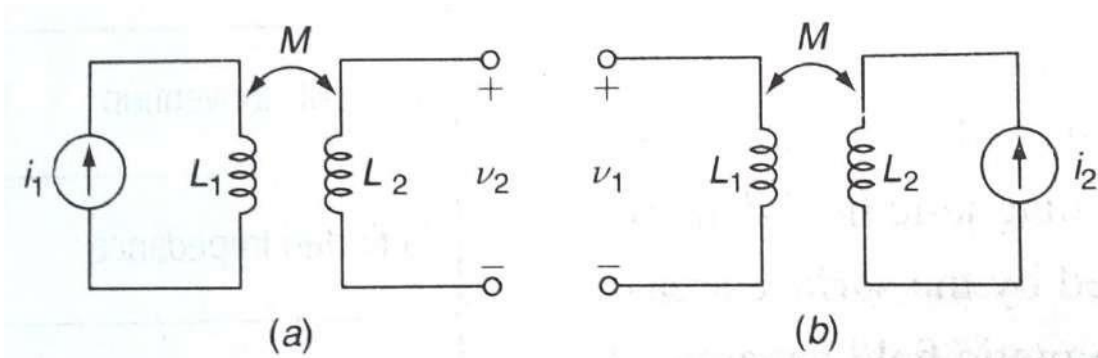
Henry is relatively a very big unit of Inductance and we normally use Inductors of the size of mH ( $10^{-3}$  H) or  $\mu$ H ( $10^{-6}$ H)

### **Mutual inductance and Coefficient of coupling:**

In the case of Self Inductance an emf is induced in the same coil which produces the varying magnetic field. The same phenomenon of Induction will be extended to a separate second coil if it is located in the vicinity of the varying magnetic field produced by the first coil. Faradays law of electromagnetic Induction is equally applicable to the second coil also. A current flowing in one coil establishes a magnetic flux about that coil and also about a second coil nearby but of course with a lesser intensity. The time-varying flux produced by the first coil and surrounding the second coil produces a voltage across the terminals of the second coil. This voltage is proportional to the time rate of change of the current flowing through the first coil.

Figure (a) shows a simple model of two coils  $L_1$  and  $L_2$ , sufficiently close together that the flux produced by a current  $i_1(t)$  flowing through  $L_1$  establishes an open-circuit voltage  $v_2(t)$  across the terminals of  $L_2$ . **Mutual inductance,  $M_{21}$** , is defined such that

$$v_2(t) = M_{21} di_1(t)/dt \text{ ----- [1]}$$



**Figure (a) A current  $i_1$  through  $L_1$  produces an open-circuit voltage  $v_2$  across  $L_2$ . (b) A current  $i_2$  through  $L_2$  produces an open-circuit voltage  $v_1$  across  $L_1$ .**

The order of the subscripts on  $M_{21}$  indicates that a voltage response is produced at  $L_2$  by a current source at  $L_1$ . If the system is reversed, as indicated in fig.(b) then we have

$$v_1(t) = M_{12} di_2(t)/dt \text{-----[2]}$$

It can be proved that the two mutual inductances  $M_{12}$  and  $M_{21}$  are equal and thus,  $M_{12} = M_{21} = M$ . The existence of mutual coupling between two coils is indicated by a double-headed arrow, as shown in Fig. (a) and (b)

Mutual inductance is measured in Henrys and, like resistance, inductance, and capacitance, is a positive quantity. The voltage  $M di/dt$ , however, may appear as either a positive or a negative quantity depending on whether the current is increasing or decreasing at a particular instant of time.

**Coefficient of coupling  $k$**  : Is given by the relation  $M = k\sqrt{L_1 L_2}$  and its value lies between 0 and 1. It can assume the maximum value of 1 when the two coils are wound on the same core such that flux produced by one coil completely links with the other coil. This is possible in well designed cores with high permeability. Transformers are designed to achieve a coefficient of coupling of 1.

### Dot Convention:

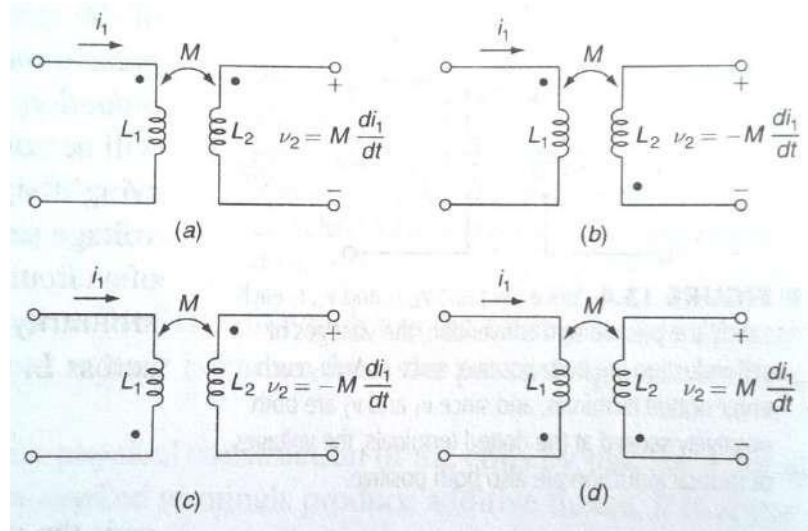
The polarity of the voltage induced in a coil depends on the sense of winding of the coil. In the case of Mutual inductance it is indicated by use of a method called "**dot convention**". The dot convention makes use of a large dot placed at one end of each of the two coils which are mutually coupled. Sign of the mutual voltage is determined as follows:

**A current entering the dotted terminal of one coil produces an open circuit voltage with a positive voltage reference at the dotted terminal of the second coil.**

Thus in Fig(a)  $i_1$  enters the dotted terminal of  $L_1$ ,  $v_2$  is sensed positively at the dotted terminal of  $L_2$ , and  $v_2 = M di_1/dt$ .

It may not be always possible to select voltages or currents throughout a circuit so that the passive sign convention is everywhere satisfied; the same situation arises with mutual coupling. For example, it may be more convenient to represent  $v_2$  by a positive voltage reference at the undotted terminal, as shown in Fig (b). Then  $v_2 = -M \frac{di_1}{dt}$ . Currents also may not always enter the dotted terminal as indicated by Fig (c) and (d). Then we note that:

**A current entering the undotted terminal of one coil provides a voltage that is positively sensed at the undotted terminal of the second coil.**



**Figure :** (a) and (b) Current entering the dotted terminal of one coil produces a voltage that is sensed positively at the dotted terminal of the second coil. (c) and (d) Current entering the undotted terminal of one coil produces a voltage that is sensed positively at the undotted terminal of the second coil.

**Important Concepts and formulae:****Resonance and Series RLC circuit:**

$$\omega_r^2 = \omega_1 \omega_2 = 1/LC \quad \therefore \omega_r = \sqrt{\omega_1 \omega_2} = 1/\sqrt{LC}$$

$$BW = R/2\pi L$$

$$Q = \omega_r L / R = 1 / \omega_r RC \quad \text{and in terms of R, L and C} = (1/R) (\sqrt{L/C})$$

$Q = f_r / BW$  i.e. inversely proportional to the BW

Voltage magnification Magnification =  $Q = V_L/V$  or  $V_C/V$

**Important points In Series RLC circuit at resonant frequency :**

- The impedance of the circuit becomes purely resistive and minimum i.e  $Z = R$
- The current in the circuit becomes maximum
- The magnitudes of the capacitive Reactance and Inductive Reactance become equal
- The voltage across the Capacitor becomes equal to the voltage across the Inductor at resonance and is  $Q$  times higher than the voltage across the resistor

**Resonance and Parallel RLC circuit:**

$$\omega_r^2 = \omega_1 \omega_2 = 1/LC \quad \therefore \omega_r = \sqrt{\omega_1 \omega_2} = 1/\sqrt{LC} \quad \text{same as in series RLC circuit}$$

$$BW = 1/2\pi RC$$

$Q = R / \omega_r L = \omega_r RC$  and in terms of R, L and C =  $R (\sqrt{C/L})$  [ Inverse of what we got in Series RLC circuit]

$Q = f_r / BW$  In Parallel RLC also inversely proportional to the BW

Current Magnification =  $Q = I_L/I$  or  $I_C / I$

**Important points In Parallel RLC circuit at resonant frequency :**

- The impedance of the circuit becomes resistive and maximum i.e  $Z = R$
- The current in the circuit becomes minimum
- The magnitudes of the capacitive Reactance and Inductive Reactance become equal
- The current through the Capacitor becomes equal and opposite to the current through the Inductor at resonance and is  $Q$  times higher than the current through the resistor

**Magnetic circuits :**

**Ampere's Law:**  $\oint H \cdot dl = I_{net}$  and in the case of a simple closed magnetic path of a ferromagnetic material it simplifies to  $HI = Ni$  or  $H = Ni/l$

Magnetic flux density:  $B = \mu H$   
 Magnetic field intensity:  $H = Ni/l$   
 Total magnetic flux intensity:  $\Phi = BA = \mu HA = \mu Ni A / l$   
 Reluctance of the magnetic circuit:  $R = \text{mmf/Flux} = Ni / \Phi = l/\mu A$

**Faradays law of electromagnetic Induction:**

Self induced e.m.f of a coil of N turns is given by:  $e_{ind} = -N d\Phi/dt = -L di/dt$  where L is the inductance of the coil of N turns with radius r and given by  $L = (\mu N^2 \pi r^2 / l) i$

Equivalent Reluctance of a series Magnetic circuit:  $R_{eqseries} = R_1 + R_2 + R_3 + \dots$

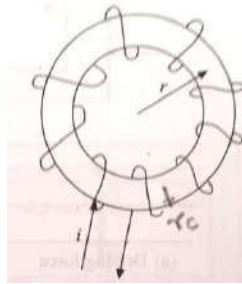
Equivalent Reluctance of a Parallel Magnetic circuit:  $1/R_{eqparallel} = 1/R_1 + 1/R_2 + 1/R_3 + \dots$

Coefficient of coupling k is given by the relation:  $M = k\sqrt{L_1 L_2}$

**Illustrative examples:**

**Example 1:** A toroidal core of radius 6 cms is having 1000 turns on it. The radius of cross section of the core 1cm. Find the current required to establish a total magnetic flux of 0.4mWb. When

- (a) The core is nonmagnetic  
 (b) The core is made of iron having a relative permeability of 4000

**Solution:**

This problem can be solved by the direct application of the following formulae we know in magnetic circuits:  $\mathbf{B = \Phi/A = \mu H}$  and  $\mathbf{H = Ni/l}$

Where

$\mathbf{B}$  = magnetic flux density (Wb/mtr<sup>2</sup>)

$\Phi$  = Total magnetic flux (Wb)

$\mathbf{A}$  = Cross sectional area of the core(mtr<sup>2</sup>)

$\mu = \mu_r \mu_0$  = Permeability (Henrys/mtr)

$\mu_r$  = Relative permeability of the material ( Dimensionless)

$\mu_0$  = free space permeability =  $4\pi \times 10^{-7}$  Henrys/mtr

$\mathbf{H}$  = Magnetic field intensity AT/mtr

$\mathbf{N}$  = Number of turns of the coil

$\mathbf{i}$  = Current in the coil (Amps)

$\mathbf{l}$  = Length of the coil (mtrs)

from the above relations we can get  $\mathbf{i}$  as

$$\mathbf{i = H l/N = (1/\mu)(\Phi/A) l / N = (1/\mu)(\Phi/N) l / A = (1/\mu)(\Phi/N) [ 2\pi r_T / \pi r_C^2 ] = [ 2r_T \Phi / \mu N r_C^2 ]}$$

Where  $r_T$  is the radius of the toroid and  $r_C$  is the radius of cross section of the coil

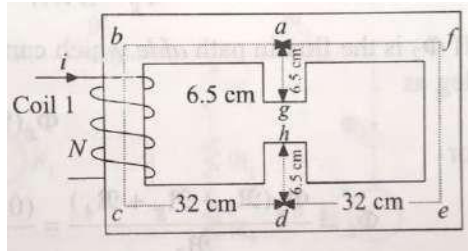
Now we can calculate the currents in the two cases by substituting the respective values.

(a) Here  $\mu = \mu_0$ . Therefore  $\mathbf{i = ( 2 \times 6 \times 10^{-2} \times 4 \times 10^{-4} ) / ( 4\pi \times 10^{-7} \times 1000 \times 10^{-4} ) = 380}$  Amps

(b) Here  $\mu = \mu_r \mu_0$ . Therefore  $\mathbf{i = ( 2 \times 6 \times 10^{-2} \times 4 \times 10^{-4} ) / ( 4000 \times 4\pi \times 10^{-7} \times 1000 \times 10^{-4} ) = 0.095}$  Amps

**Ex.2: (a)** Draw the electrical equivalent circuit of the magnetic circuit shown in the figure below. The area of the core is  $2 \times 2 \text{ cm}^2$ . The length of the air gap is 1 cm and lengths of the other limbs are shown in the figure. The relative permeability of the core is 4000.

**(b)** Find the value of the current 'i' in the above example which produces a flux density of 1.2 Tesla in the air gap. The number f turns of the coil are 5000.



**Solution: (a)**

To draw the equivalent circuit we have to find the Reluctances of the various flux paths independently.

The reluctance of the path *abcd* is given by:  $R_1 = \text{length of the path } abcd / \mu_r \mu_0 A$

$$= (32 \times 10^{-2}) / (4\pi \times 10^{-7} \times 4000 \times 4 \times 10^{-4}) = 1.59 \times 10^5 \text{ AT/Wb}$$

The reluctance of the path *afed* is equal to the reluctance of the path *abcd* since it has the same length, same permeability and same cross sectional area. Thus  $R_1 = R_2$

Similarly the reluctance of the path *ag* ( $R_3$ ) is equal to that of the path *hd* ( $R_4$ ) and can be calculated as:

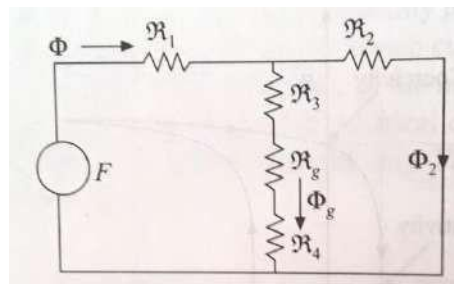
$$R_3 = R_4 = (6.5 \times 10^{-2}) / (4\pi \times 10^{-7} \times 4000 \times 4 \times 10^{-4}) = 0.32 \times 10^5 \text{ AT/Wb}$$

The reluctance of the air gap path *gh*  $R_G$  can be calculated as :  $R_G = \text{length of the air gap path } gh / \mu_0 A$

( Here it is to be noted that  $\mu$  is to be taken as  $\mu_0$  only and  $\mu_r$  should not be included)

$$R_G = (1 \times 10^{-2}) / (4\pi \times 10^{-7} \times 4 \times 10^{-4}) = 198.94 \times 10^5 \text{ AT/Wb}$$

The equivalent electrical circuit is shown in the figure below with the values of the reluctances as given below the circuit diagram.



$$R_1 = R_2 = 1.59 \times 10^5 \text{ AT/Wb} \quad R_3 = R_4 = 0.32 \times 10^5 \text{ AT/Wb} \quad R_G = 198.94 \times 10^5 \text{ AT/Wb}$$

**Solution: (b)** This problem is solved in the following steps:

- 1. First the flux through the air gap  $\Phi_G$  is found out.** The flux in the air gap  $\Phi_G$  is given by the product of the Flux density in the air gap  $B$  and the cross sectional area of the core in that region  $A$ . Hence  $\Phi_G = B.A = 1.2 \times 4 \times 10^{-4} = 0.00048 \text{ Wb}$   
It is to be noted here that the same flux would be passing through the reluctances  $R_3, R_G$  &  $R_4$
- 2. Next, the Flux in the path *afed*  $\Phi_2$  is to be found out.** This can be found out by noticing that the mmf across the reluctance  $R_2$  is same as the mmf across the sum of the reluctances  $R_3, R_G$ , and  $R_4$  coming in parallel with  $R_4$ . Hence by equating them we get

$$\Phi_G (R_3 + R_G + R_4) = \Phi_2 R_2 \text{ from which we get } \Phi_2 = \Phi_G (R_3 + R_G + R_4) / R_2$$

$$\text{Hence } \Phi_2 = [0.00048 \times (0.32 + 198.94 + 0.32) \times 10^5] / 1.59 \times 10^5 = 0.06025 \text{ Wb}$$

- 3. Next, the total flux  $\Phi$  flowing through the reluctance of the path *abcd*  $R_1$  produced by the winding is to be found out.** This is the sum of the air gap flux  $\Phi_G$  and the flux in the outer limb of the core  $\Phi_2$ : i.e  $\Phi = \Phi_G + \Phi_2 = (0.00048 + 0.06025) = 0.0607 \text{ Wb}$
- 4. Next, The total mmf  $F$  given by  $F = Ni$  is to be found out.** This is also equal to the sum of the mmfs across the reluctances  $R_1$  and  $R_2$  [or  $(R_3 + R_G + R_4)$ ] =  $\Phi R_1 + \Phi_2 R_2$  from which we can get 'i' as: 'i' =  $(\Phi R_1 + \Phi_2 R_2) / N = [0.0607 \times 1.59 \times 10^5 + 0.06025 \times 1.59 \times 10^5] / 5000 = 3.847 \text{ Amps}$

$$i_s = 3.847 \text{ Amps}$$



## UNIT-5

### TWO PORT NETWORKS

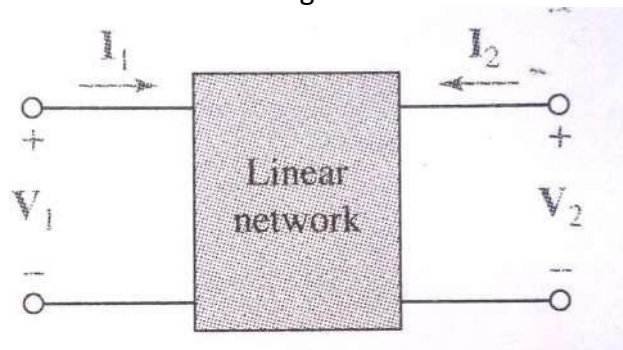
- Introduction
- Impedance Parameters
- Admittance Parameters
- Hybrid Parameters
- Transmission Parameters (ABC D)
- Conversion of one Parameter to other
- Conditions for reciprocity and symmetry
- Interconnection of two port networks in Series ,Parallel and Cascaded configurations
- Image parameters
  - Important Formulae, equations and relations
  - Illustrative problems

## Introduction:

A general network having two pairs of terminals, one labeled the “input terminals” and the other the “output terminals,” is a very important building block in electronic systems, communication systems, automatic control systems, transmission and distribution systems, or other systems in which an electrical signal or electric energy enters the input terminals, is acted upon by the network, and leaves via the output terminals. A pair of terminals at which a signal may enter or leave a network is also called a **port**, and a network like the above having two such pair of terminals is called a **Two - port network**. A general two-port network with terminal voltages and currents specified is shown in the figure below. In such networks the relation between the two voltages and the two currents can be described in six different ways resulting in six different systems of Parameters and in this chapter we will consider the most important four systems.

## Impedance Parameters: Z parameters (open circuit impedance parameters)

We will assume that the two port networks that we will consider are composed of linear elements and contain no independent sources but dependent sources *are* permissible. We will consider the two-port network as shown in the figure below.



**Fig: A general two-port network with terminal voltages and currents specified. The two-port network is composed of linear elements, possibly including dependent sources, but not containing any independent sources.**

The voltage and current at the input terminals are  $V_1$  &  $I_1$ , and  $V_2$  &  $I_2$  are voltage and current at the output port. The directions of  $I_1$  and  $I_2$  are both customarily selected as *into* the network at the upper conductors (and out at the lower conductors). Since the network is linear and contains no independent sources within it,  $V_1$  may be considered to be the superposition of two components, one caused by  $I_1$  and the other by  $I_2$ . When the same argument is applied to  $V_2$ , we get the set of equations

$$V_1 = Z_{11}I_1 + Z_{12}I_2$$

$$V_2 = Z_{21}I_1 + Z_{22}I_2$$

This set of equations can be expressed in matrix notation as

$$\begin{bmatrix} V_1 \\ V_2 \end{bmatrix} = \begin{bmatrix} Z_{11} & Z_{12} \\ Z_{21} & Z_{22} \end{bmatrix} \begin{bmatrix} I_1 \\ I_2 \end{bmatrix}$$

And in much simpler form as

$$[\mathbf{V}] = [\mathbf{Z}][\mathbf{I}]$$

Where  $[\mathbf{V}]$ ,  $[\mathbf{Z}]$  and  $[\mathbf{I}]$  are Voltage, impedance and current matrices. The description of the  $\mathbf{Z}$  parameters, defined in the above equations is obtained by setting each of the currents equal to zero as given below.

$$Z_{11} = V_1/I_1 \quad | \quad I_2=0$$

$$Z_{12} = V_1/I_2 \quad | \quad I_1=0$$

$$Z_{21} = V_2/I_1 \quad | \quad I_2=0$$

$$Z_{22} = V_2/I_2 \quad | \quad I_1=0$$

Thus, since zero current results from an open-circuit termination, the  $\mathbf{Z}$  parameters are known as the **Open-circuit Impedance parameters**. And more specifically  $Z_{11}$  &  $Z_{22}$  are called **Driving point Impedances** and  $Z_{12}$  &  $Z_{21}$  are called **Reverse and Forward transfer impedances** respectively.

A basic  $\mathbf{Z}$  parameter equivalent circuit depicting the above defining equations is shown in the figure below.

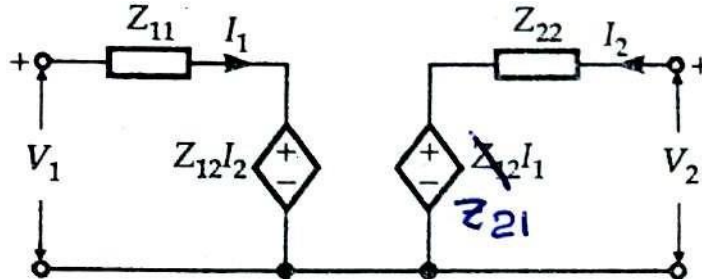
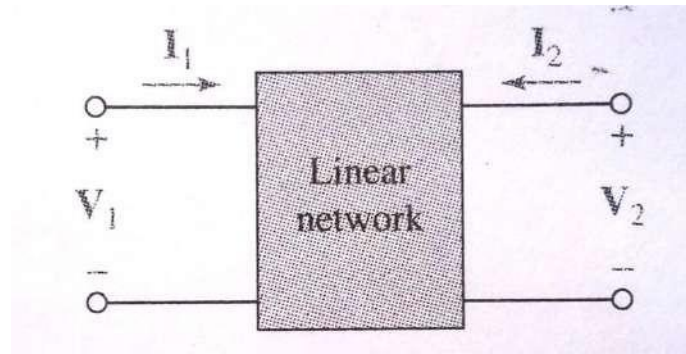


Fig: Z-Parameter equivalent circuit

### Admittance parameters: ( Y Parameters or Short circuit admittance parameters)

The same general two port network shown for  $\mathbf{Z}$  parameters is applicable here also and is shown below.



**Fig: A general two-port network with terminal voltages and currents specified. The two-port network is composed of linear elements, possibly including dependent sources, but not containing any independent sources.**

Since the network is linear and contains no independent sources within, on the same lines of  $Z$  parameters the defining equations for the  $Y$  parameters are given below.  $I_1$  and  $I_2$  may be considered to be the superposition of two components, one caused by  $V_1$  and the other by  $V_2$  and then we get the set of equations defining the  $Y$  parameters.

$$I_1 = Y_{11}V_1 + Y_{12}V_2$$

$$I_2 = Y_{21}V_1 + Y_{22}V_2$$

where the  $Y$ s are no more than proportionality constants and their dimensions are A/V (Current/Voltage). Hence they are called the  $Y$  (or admittance) parameters. They are also defined in the matrix form given below.

$$\begin{matrix} I_1 & Y_{11} & Y_{12} & V_1 \\ I_2 & Y_{21} & Y_{22} & V_2 \end{matrix}$$

And in much simpler form as

$$[I] = [Y][V]$$

The individual  $Y$  parameters are defined on the same lines as  $Z$  parameters but by setting either of the voltages  $V_1$  and  $V_2$  as zero as given below.

The most informative way to attach a physical meaning to the  $y$  parameters is through a direct inspection of defining equations. The conditions which must be applied to the basic defining equations are very important. In the first equation for example; if we let  $V_2$  zero, then  $Y_{11}$  is given by the ratio of  $I_1$  to  $V_1$ . We therefore describe  $Y_{11}$  as the admittance measured at the input terminals with the output terminals *short-circuited* ( $V_2 = 0$ ). Each of the  $Y$  parameters may be described as a **current-voltage** ratio with either  $V_1 = 0$  (the input terminals short circuited) or  $V_2 = 0$  (the output terminals short-circuited):

$$\begin{aligned}
 Y_{11} &= I_1/V_1 \quad \text{with} \quad V_2 = 0 \\
 Y_{12} &= I_1/V_2 \quad \text{with} \quad V_1 = 0 \\
 Y_{21} &= I_2/V_1 \quad \text{with} \quad V_2 = 0 \\
 Y_{22} &= I_2/V_2 \quad \text{with} \quad V_1 = 0
 \end{aligned}$$

Because each parameter is an **admittance** which is obtained by short circuiting either the output or the input port, the **Y** parameters are known as the **short-circuit admittance parameters**. The specific name of  **$Y_{11}$**  is the **short-circuit input admittance**,  **$Y_{22}$**  is the **short-circuit output admittance**, and  **$Y_{12}$**  and  **$Y_{21}$**  are the **short-circuit reverse and forward transfer admittances respectively**.

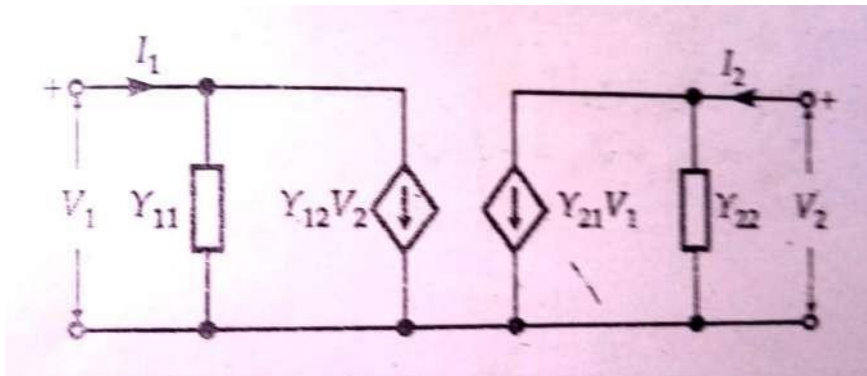


Fig: Y parameter equivalent circuit

### Hybrid parameters: ( h parameters )

**h** parameter representation is used widely in modeling of Electronic components and circuits particularly Transistors. Here both short circuit and open circuit conditions are utilized. The hybrid parameters are defined by writing the pair of equations relating  **$V_1$** ,  **$I_1$** ,  **$V_2$** , and  **$I_2$** :

$$\begin{aligned}
 V_1 &= h_{11} \cdot I_1 + h_{12} \cdot V_2 \\
 I_2 &= h_{21} \cdot I_1 + h_{22} \cdot V_2
 \end{aligned}$$

Or in matrix form :

$$\begin{array}{cc}
 V_1 & I_1 \\
 \mathbf{h} & \\
 I_2 & V_2
 \end{array}$$

The nature of the parameters is made clear by first setting  **$V_2 = 0$** . Thus,

$$\begin{aligned}
 h_{11} &= V_1/I_1 \quad \text{with} \quad V_2 = 0 && = \text{short-circuit input impedance} \\
 h_{21} &= I_2/I_1 \quad \text{with} \quad V_2 = 0 && = \text{short-circuit forward current gain}
 \end{aligned}$$

Then letting  $I_1 = 0$ , we obtain

$$h_{12} = V_1/V_2 \quad \text{with } I_1=0 \quad = \textit{open-circuit reverse voltage gain}$$

$$h_{22} = I_2/V_2 \quad \text{with } I_1=0 \quad = \textit{open-circuit output admittance}$$

Since the parameters represent an impedance, an admittance, a voltage gain, and a current gain, they are called the "hybrid" parameters.

The subscript designations for these parameters are often simplified when they are applied to transistors. Thus,  $h_{11}$ ,  $h_{12}$ ,  $h_{21}$ , and  $h_{22}$  become  $h_i$ ,  $h_r$ ,  $h_f$ , and  $h_o$ , respectively, where the subscripts denote input, reverse, forward, and output.

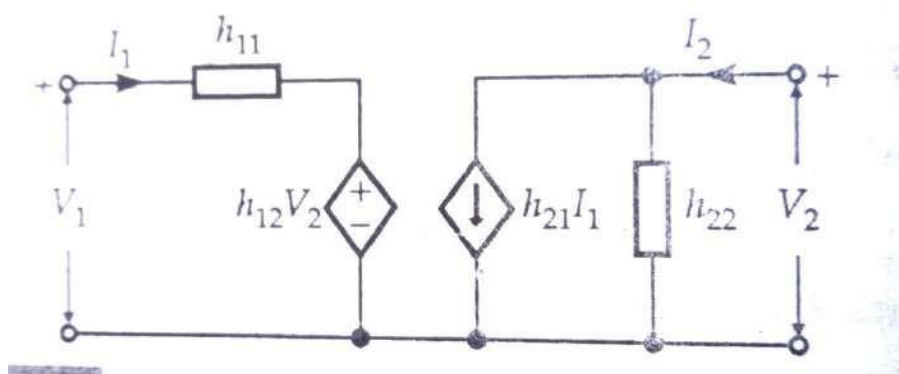


Fig: h parameter equivalent circuit

### Transmission parameters:

The last two-port parameters that we will consider are called the **t parameters**, the **ABCD parameters**, or simply the **transmission parameters**. They are defined by the equations

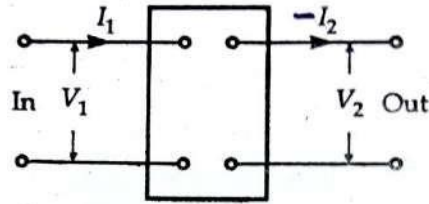
$$V_1 = A.V_2 - B.I_2$$

$$I_1 = C.V_2 - D.I_2$$

and in Matrix notation these equations can be written in the form

$$\begin{matrix} V_1 & = & A & B & V_2 \\ I_1 & = & C & D & -I_2 \end{matrix}$$

where  $V_1$ ,  $V_2$ ,  $I_1$ , and  $I_2$  are defined as as shown in the figure below.



**Fig: Two port Network for ABCD parameter representation with Input and output Voltages and currents**

The minus signs that appear in the above equations should be associated with the output current, as  $(-I_2)$ . Thus, both  $I_1$  and  $-I_2$  are directed to the right, the direction of energy or signal transmission.

Note that there are no minus signs in the **t** or **ABCD** matrices. Looking again at the above equations we see that the quantities on the left, often thought of as the given or independent variables, are the input voltage and current,  $V_1$  and  $I_1$ ; the dependent variables,  $V_2$  and  $I_2$ , are the output quantities. Thus, the transmission parameters provide a direct relationship between input and output. Their major use arises in transmission-line analysis and in cascaded networks.

The four Transmission parameters are defined and explained below.

First **A** and **C** are defined with receiving end open circuited i.e. with  $I_2 = 0$

$$\mathbf{A} = V_1/V_2 \quad \text{with } I_2 = 0 \quad = \text{Reverse voltage Ratio}$$

$$\mathbf{C} = I_1/V_2 \quad \text{with } I_2 = 0 \quad = \text{Transfer admittance}$$

Next **B** and **D** are defined with receiving end short circuited i.e. with  $V_2 = 0$

$$\mathbf{B} = V_1/-I_2 \quad \text{with } V_2 = 0 \quad = \text{Transfer impedance}$$

$$\mathbf{D} = I_1/-I_2 \quad \text{with } V_2 = 0 \quad = \text{Reverse current ratio}$$

### Inter relationships between different parameters of two port networks:

*Basic Procedure for representing any of the above four two port Network parameters in terms of the other parameters consists of the following steps:*

1. Write down the defining equations corresponding to the parameters in terms of which the other parameters are to be represented.
2. Keeping the basic parameters same, rewrite/manipulate these two equations in such a way that the variables  $V_1, V_2, I_1$ , and  $I_2$  are arranged corresponding to the defining equations of the first parameters.
3. Then by comparing the parameter coefficients of the respective variables  $V_1, V_2, I_1$ , and  $I_2$  on the right hand side of the two sets of equations we can get the inter relationship.

**Z Parameters in terms of Y parameters:**

*Though this relationship can be obtained by the above steps, the following simpler method is used for Z in terms of Y and Y in terms of Z:*

Z and Y being the Impedance and admittance parameters (Inverse), in matrix notation they are governed by the following inverse relationship.

$$[Z] = [Y]^{-1}$$

Or:

$$\begin{bmatrix} Z_{11} & Z_{12} \\ Z_{21} & Z_{22} \end{bmatrix} = \begin{bmatrix} Y_{11} & Y_{12} \\ Y_{21} & Y_{22} \end{bmatrix}^{-1}$$

Thus :

$$Z_{11} = \frac{Y_{22}}{\Delta Y}, Z_{12} = -\frac{Y_{12}}{\Delta Y}$$

$$Z_{21} = -\frac{Y_{21}}{\Delta Y} \text{ and } Z_{22} = \frac{Y_{11}}{\Delta Y}$$

$$\left[ \text{Here } \Delta Y = \begin{bmatrix} Y_{11} & Y_{12} \\ Y_{21} & Y_{22} \end{bmatrix} = Y_{11} Y_{22} - Y_{12} Y_{21} \right]$$

**Z Parameters in terms of ABCD parameters:**

The governing equations are:

$$V_1 = AV_2 - BI_2$$

$$I_1 = CV_2 - DI_2$$

from the second governing equation  $[I_1 = CV_2 - DI_2]$  we can write

$$V_2 = \frac{1}{C} \cdot I_1 + \frac{D}{C} \cdot I_2$$

Now substituting this value of  $V_2$  in the first governing equation  $[V_1 = AV_2 - BI_2]$  we get

$$V_1 = \left[ \frac{1}{C} \cdot I_1 + \frac{D}{C} \cdot I_2 \right] A - BI_2$$

$$= \frac{A}{C} \cdot I_1 + \frac{AD - BC}{C} \cdot I_2$$

Comparing these two equations for  $V_1$  and  $V_2$  with the governing equations of the Z parameter network we get Z Parameters in terms of ABCD parameters:



$$Z_{11} = \frac{A}{C}, Z_{12} = \frac{AD - BC}{C}$$

$$Z_{21} = \frac{1}{C}, Z_{22} = \frac{D}{C}$$

### Z Parameters in terms of h parameters:

The governing equations of h parameter network are:

$$V_1 = h_{11}I_1 + h_{12}V_2$$

$$I_2 = h_{21}I_1 + h_{22}V_2$$

From the second equation we get

$$V_2 = -\frac{h_{21}}{h_{22}} \cdot I_1 + \frac{1}{h_{22}} \cdot I_2$$

Substituting this value of  $V_2$  in the first equation for  $V_1$  we get:

$$\begin{aligned} V_1 &= h_{11}I_1 + h_{12}V_2 \\ &= h_{11}I_1 + h_{12} \left[ -\frac{h_{21}}{h_{22}} I_1 + \frac{1}{h_{22}} \cdot I_2 \right] \\ &= \frac{\Delta h}{h_{22}} I_1 + \frac{h_{12}}{h_{22}} \cdot I_2 \end{aligned}$$

Now comparing these two equations for  $V_1$  and  $V_2$  with the governing equations of the Z parameter network we get Z Parameters in terms of h parameters:

$$Z_{11} = \frac{\Delta h}{h_{22}}, Z_{12} = \frac{h_{12}}{h_{22}}$$

$$Z_{21} = -\frac{h_{21}}{h_{22}}, Z_{22} = \frac{1}{h_{22}}$$

$$\text{Here } \Delta h = h_{11}h_{22} - h_{12}h_{21}$$

### Y Parameters in terms of Z parameters:

Y and Z being the admittance and Impedance parameters (Inverse), in matrix notation they are governed by the following inverse relationship.

$$[Y] = [Z]^{-1}$$

Or:

$$\begin{bmatrix} Y_{11} & Y_{12} \\ Y_{21} & Y_{22} \end{bmatrix} = \begin{bmatrix} Z_{11} & Z_{12} \\ Z_{21} & Z_{22} \end{bmatrix}^{-1}$$

Thus:

$$Y_{11} = \frac{Z_{22}}{\Delta Z}, \quad Y_{12} = -\frac{Z_{12}}{\Delta Z}$$

$$Y_{21} = -\frac{Z_{21}}{\Delta Z}, \quad Y_{22} = \frac{Z_{11}}{\Delta Z}$$

$$\text{Here } \Delta Z = Z_{11} Z_{22} - Z_{12} Z_{21}$$

The other inter relationships also can be obtained on the same lines following the **basic three steps given** in the beginning.

### Conditions for reciprocity and symmetry in two port networks:

A two port network is said to be **reciprocal** if the ratio of the output response variable to the input excitation variable is same when the excitation and response ports are interchanged.

A two port network is said to be **symmetrical** if the port voltages and currents remain the same when the input and output ports are interchanged.

In this topic we will get the conditions for **Reciprocity** and **symmetry** for all the four networks. The basic procedure for each of the networks consists of the following steps:

#### Reciprocity:

- First we will get an expression for the ratio of response to the excitation in terms of the **particular parameters** by giving voltage as excitation at the input port and considering the current in the output port as response ( by short circuiting the output port i.e setting  $V_2$  as zero ). i.e find out (  $I_2 / V_1$  )
- Then we will get an expression for the ratio of response to the excitation in terms of the **same parameters** by giving voltage as excitation at the output port and considering the current in the input port as response ( by short circuiting the input port i.e. setting  $V_1$  as zero ). i.e find out (  $I_1 / V_2$  )
- Equating the RHS of these two expressions would be the condition for reciprocity

**Symmetry:**

- First we need to get expressions related to the input and output ports using the basic Z or Y parameter equations.
- Then the expressions for  $Z_{11}$  and  $Z_{22}$  ( or  $Y_{11}$  and  $Y_{22}$  ) are equated to get the condition for reciprocity.

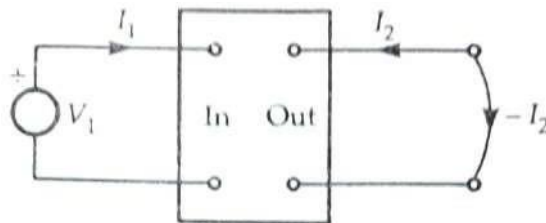
**Z parameter representation:****Condition for reciprocity:**

Let us take a two port network with Z parameter defining equations as given below:

$$V_1 = Z_{11}I_1 + Z_{12}I_2$$

$$V_2 = Z_{21}I_1 + Z_{22}I_2$$

First we will get an expression for the ratio of response ( $I_2$ ) to the excitation ( $V_1$ ) in terms of the **Z parameters** by giving excitation at the input port and considering the current in the output port as response ( by short circuiting the output port i.e. setting  $V_2$  as zero ).The corresponding Z parameter circuit for this condition is shown in the figure below:



*( Pl note the direction of  $I_2$  is negative since when  $V_2$  port is shorted the current flows in the other direction )*

Then the Z parameter defining equations are :

$$V_1 = Z_{11} \cdot I_1 - Z_{12} \cdot I_2 \text{ and}$$

$$0 = Z_{21} \cdot I_1 - Z_{22} \cdot I_2$$

*To get the ratio of response ( $I_2$ ) to the excitation ( $V_1$ ) in terms of the Z parameters  $I_1$  is to be eliminated from the above equations.*

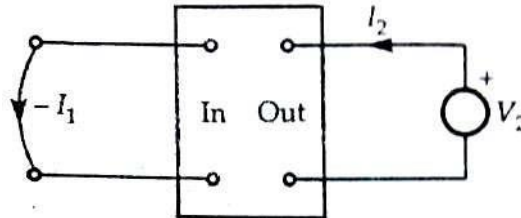
So from equation 2 in the above set we will get  $I_1 = I_2 \cdot Z_{22} / Z_{21}$

And substitute this in the first equation to get

$$V_1 = (Z_{11} \cdot I_2 \cdot Z_{22} / Z_{21}) - Z_{12} \cdot I_2 = I_2 [(Z_{11} \cdot Z_{22} / Z_{21}) - Z_{12}] = I_2 [(Z_{11} \cdot Z_{22} - Z_{12} \cdot Z_{21}) / Z_{21}]$$

$$I_2 = V_1 \cdot Z_{21} / (Z_{11} \cdot Z_{22} - Z_{12} \cdot Z_{21})$$

Next, we will get an expression for the ratio of response ( $I_1$ ) to the excitation ( $V_2$ ) in terms of the **Z parameters** by giving excitation  $V_2$  at the output port and considering the current  $I_1$  in the input port as response (by short circuiting the input port i.e. setting  $V_1$  as zero). The corresponding Z parameter circuit for this condition is shown in the figure below:



*( Please note the direction of current  $I_1$  is negative since when  $V_1$  port is shorted the current flows in the other direction )*

Then the Z parameter defining equations are :

$$0 = -Z_{11} \cdot I_1 + Z_{12} \cdot I_2 \text{ and}$$

$$V_2 = -Z_{21} \cdot I_1 + Z_{22} \cdot I_2$$

To get the ratio of response ( $I_1$ ) to the excitation ( $V_2$ ) in terms of the Z parameters  $I_2$  is to be eliminated from the above equations.

So from equation 1 in the above set we will get  $I_2 = I_1 \cdot Z_{11} / Z_{12}$

And substitute this in the second equation to get

$$V_2 = (Z_{22} \cdot I_1 \cdot Z_{11} / Z_{12}) - Z_{21} \cdot I_1 = I_1 [(Z_{11} \cdot Z_{22} / Z_{12}) - Z_{21}] = I_1 [(Z_{11} \cdot Z_{22} - Z_{12} \cdot Z_{21}) / Z_{12}]$$

$$I_1 = V_2 \cdot Z_{12} / (Z_{11} \cdot Z_{22} - Z_{12} \cdot Z_{21})$$

Assuming the input excitations  $V_1$  and  $V_2$  to be the same, then the condition for the out responses  $I_1$  and  $I_2$  to be equal would be

$$Z_{12} = Z_{21}$$

**And this is the condition for the reciprocity.**

**Condition for symmetry:**

To get this condition we need to get expressions related to the input and output ports using the basic Z parameter equations.

$$\mathbf{V}_1 = \mathbf{Z}_{11}\mathbf{I}_1 + \mathbf{Z}_{12}\mathbf{I}_2$$

$$\mathbf{V}_2 = \mathbf{Z}_{21}\mathbf{I}_1 + \mathbf{Z}_{22}\mathbf{I}_2$$

To get the input port impedance  $\mathbf{I}_2$  is to be made zero. i.e  $\mathbf{V}_2$  should be open.

$$\mathbf{V}_1 = \mathbf{Z}_{11} \cdot \mathbf{I}_1 \quad \text{i.e} \quad \mathbf{Z}_{11} = \mathbf{V}_1/\mathbf{I}_1 \quad | \quad \mathbf{I}_2=0$$

Similarly to get the output port impedance  $\mathbf{I}_1$  is to be made zero. i.e  $\mathbf{V}_1$  should be open.

$$\mathbf{V}_2 = \mathbf{Z}_{22} \cdot \mathbf{I}_2 \quad \text{i.e} \quad \mathbf{Z}_{22} = \mathbf{V}_2/\mathbf{I}_2 \quad | \quad \mathbf{I}_1=0$$

Condition for Symmetry is obtained when the two port voltages are equal i.e.  $\mathbf{V}_1 = \mathbf{V}_2$  and the two port currents are equal i.e.  $\mathbf{I}_1 = \mathbf{I}_2$ . Then

$$\mathbf{V}_1/\mathbf{I}_1 = \mathbf{V}_2/\mathbf{I}_2 \quad \text{i.e} \quad \mathbf{Z}_{11} = \mathbf{Z}_{22}$$

**And hence  $\mathbf{Z}_{11} = \mathbf{Z}_{22}$  is the condition for symmetry in Z parameters .**

### Y parameter representation:

#### Condition for reciprocity :

Let us take a two port network with Y parameter defining equations as given below:

$$\mathbf{I}_1 = \mathbf{Y}_{11}\mathbf{V}_1 + \mathbf{Y}_{12}\mathbf{V}_2$$

$$\mathbf{I}_2 = \mathbf{Y}_{21}\mathbf{V}_1 + \mathbf{Y}_{22}\mathbf{V}_2$$

First we will get an expression for the ratio of response ( $\mathbf{I}_2$ ) to the excitation ( $\mathbf{V}_1$ ) in terms of the Y parameters by giving excitation ( $\mathbf{V}_1$ ) at the input port and considering the current ( $\mathbf{I}_2$ ) in the output port as response ( by short circuiting the output port i.e. setting  $\mathbf{V}_2$  as zero )

Then the second equation in Y parameter defining equations would become

$$\mathbf{I}_2 = \mathbf{Y}_{21}\mathbf{V}_1 + 0 \quad \text{and} \quad \mathbf{I}_2/\mathbf{V}_1 = \mathbf{Y}_{21}$$

Then we will get an expression for the ratio of response ( $\mathbf{I}_1$ ) to the excitation ( $\mathbf{V}_2$ ) in terms of the Y parameters by giving excitation ( $\mathbf{V}_2$ ) at the output port and considering the current ( $\mathbf{I}_1$ ) in the input port as response ( by short circuiting the input port i.e setting  $\mathbf{V}_1$  as zero )

Then the first equation in Y parameter defining equations would become

$$\mathbf{I}_1 = 0 + \mathbf{Y}_{12}\mathbf{V}_2 \quad \text{and} \quad \mathbf{I}_1/\mathbf{V}_2 = \mathbf{Y}_{12}$$

Assuming the input excitations  $V_1$  and  $V_2$  to be the same, then the condition for the out responses  $I_1$  and  $I_2$  to be equal would be

$$I_1 / V_2 = I_2 / V_1$$

**And hence  $Y_{12} = Y_{21}$  is the condition for the reciprocity in the Two port network with Y parameter representation.**

**Condition for symmetry:**

To get this condition we need to get expressions related to the input and output ports ( In this case Input and output admittances ) using the basic Y parameter equations

$$\begin{aligned} I_1 &= Y_{11}V_1 + Y_{12}V_2 \\ I_2 &= Y_{21}V_1 + Y_{22}V_2 \end{aligned}$$

To get the input port admittance,  $V_2$  is to be made zero. i.e  $V_2$  should be shorted.

$$I_1 = Y_{11} \cdot V_1 \quad \text{i.e} \quad Y_{11} = I_1 / V_1 \quad | \quad V_2 = 0$$

Similarly to get the output port admittance  $V_1$  is to be made zero. i.e  $V_1$  should be shorted.

$$I_2 = Y_{22} \cdot V_2 \quad \text{i.e} \quad Y_{22} = I_2 / V_2 \quad | \quad V_1 = 0$$

Condition for Symmetry is obtained when the two port voltages are equal i.e.  $V_1 = V_2$  and the two port currents are equal i.e.  $I_1 = I_2$ . Then

$$I_1 / V_1 = I_2 / V_2$$

**And hence  $Y_{11} = Y_{22}$  is the condition for symmetry in Y parameters.**

**ABCD parameter representation:**

**Condition for reciprocity :**

Let us take a two port network with ABCD parameter defining equations as given below:

$$\begin{aligned} V_1 &= A.V_2 - B.I_2 \\ I_1 &= C.V_2 - D.I_2 \end{aligned}$$

First we will get an expression for the ratio of response ( $I_2$ ) to the excitation ( $V_1$ ) in terms of the **ABCD parameters** by giving excitation ( $V_1$ ) at the input port and considering the current ( $I_2$ ) in the output port as response ( by short circuiting the output port i.e. setting  $V_2$  as zero )

Then the first equation in the **ABCD** parameter defining equations would become

$$\begin{aligned}V_1 &= 0 - B.I_2 = B.I_2 \\ \text{i.e } I_2 / V_1 &= -1/B\end{aligned}$$

Then we will interchange the excitation and response i.e. we will get an expression for the ratio of response ( $I_1$ ) to the excitation ( $V_2$ ) by giving excitation ( $V_2$ ) at the output port and considering the current ( $I_1$ ) in the input port as response ( by short circuiting the input port i.e. setting  $V_1$  as zero )

Then the above defining equations would become

$$\begin{aligned}0 &= A.V_2 - B.I_2 \\ I_1 &= C.V_2 - D.I_2\end{aligned}$$

Substituting the value of  $I_2 = A.V_2/B$  from first equation into the second equation we get

$$\begin{aligned}I_1 &= C.V_2 - D. A.V_2/B = V_2 (C - D. A/B) \\ \text{i.e } I_1/V_2 &= (BC - DA) / B = -(AD - BC)/B\end{aligned}$$

Assuming the input excitations  $V_1$  and  $V_2$  to be the same , then the condition for the out responses  $I_1$  and  $I_2$  to be equal would be

$$\begin{aligned}I_1/V_2 &= I_2/V_1 \\ \text{i.e } -(AD - BC)/B &= -1/B \\ \text{i.e } (AD - BC) &= 1\end{aligned}$$

**And hence  $AD - BC = 1$  is the condition for Reciprocity in the Two port network with ABCD parameter representation.**

**Condition for symmetry:**

To get this condition we need to get expressions related to the input and output ports. In this case it is easy to use the Z parameter definitions of  $Z_{11}$  and  $Z_{22}$  for the input and output ports respectively and get their values in terms of the ABCD parameters as shown below.

$$\begin{aligned}V_1 &= A.V_2 - B.I_2 \\ I_1 &= C.V_2 - D.I_2\end{aligned}$$

$$Z_{11} = V_1/I_1 \mid I_2=0$$

Applying this in both the equations we get

$$\begin{aligned}Z_{11} = V_1/I_1 \mid I_2=0 &= (A.V_2 - B.I_2)/(C.V_2 - D.I_2) \mid I_2=0 \\ &= (A.V_2 - B.0)/(C.V_2 - D.0) \\ &= (A.V_2)/(C.V_2) = A/C\end{aligned}$$

$$Z_{11} = A/C$$

$$\text{Similarly } Z_{22} = V_2/I_2 \mid I_1=0$$

and using this in the second basic equation  $I_1 = C.V_2 - D.I_2$

$$\text{we get } \mathbf{0} = \mathbf{C.V}_2 - \mathbf{D.I}_2 \text{ or } \mathbf{C.V}_2 = \mathbf{D.I}_2$$

$$\mathbf{V}_2 / \mathbf{I}_2 = \mathbf{D/C}$$

$$\mathbf{Z}_{22} = \mathbf{D/C}$$

And the condition for symmetry becomes  $\mathbf{Z}_{11} = \mathbf{Z}_{22}$  i.e  $\mathbf{A/C} = \mathbf{D/C}$

$$\text{Or } \mathbf{A} = \mathbf{D}$$

Hence  $\mathbf{A} = \mathbf{D}$  is the condition for Symmetry in ABCD parameter representation.

### h parameter representation:

#### Condition for reciprocity :

Let us take a two port network with h parameter defining equations as given below:

$$\mathbf{V}_1 = \mathbf{h}_{11} \cdot \mathbf{I}_1 + \mathbf{h}_{12} \cdot \mathbf{V}_2$$

$$\mathbf{I}_2 = \mathbf{h}_{21} \cdot \mathbf{I}_1 + \mathbf{h}_{22} \cdot \mathbf{V}_2$$

First we will get an expression for the ratio of response ( $\mathbf{I}_2$ ) to the excitation ( $\mathbf{V}_1$ ) in terms of the **h parameters** by giving excitation ( $\mathbf{V}_1$ ) at the input port and considering the current ( $\mathbf{I}_2$ ) in the output port as response ( by short circuiting the output port i.e. setting  $\mathbf{V}_2$  as zero )

Then the first equation in the **h** parameter defining equations would become

$$\mathbf{V}_1 = \mathbf{h}_{11} \cdot \mathbf{I}_1 + \mathbf{h}_{12} \cdot \mathbf{0} = \mathbf{h}_{11} \cdot \mathbf{I}_1$$

And in the same condition the second equation in the **h** parameter defining equations would become

$$\mathbf{I}_2 = \mathbf{h}_{21} \cdot \mathbf{I}_1 + \mathbf{h}_{22} \cdot \mathbf{0} = \mathbf{h}_{21} \cdot \mathbf{I}_1$$

Dividing the second equation by the first equation we get

$$\mathbf{I}_2 / \mathbf{V}_1 = (\mathbf{h}_{21} \cdot \mathbf{I}_1) / (\mathbf{h}_{11} \cdot \mathbf{I}_1) = \mathbf{h}_{21} / \mathbf{h}_{11}$$

Now the excitation and the response ports are interchanged and then we will get an expression for the ratio of response ( $\mathbf{I}_1$ ) to the excitation ( $\mathbf{V}_2$ ) in terms of the **h parameters** by giving excitation ( $\mathbf{V}_2$ ) at the output port and considering the current ( $\mathbf{I}_1$ ) in the input port as response ( by short circuiting the input port i.e. setting  $\mathbf{V}_1$  as zero )

Then the first equation in **h** parameter defining equations would become

$$\mathbf{0} = \mathbf{h}_{11} \cdot \mathbf{I}_1 + \mathbf{h}_{12} \cdot \mathbf{V}_2 \text{ i.e } \mathbf{h}_{11} \cdot \mathbf{I}_1 = -\mathbf{h}_{12} \cdot \mathbf{V}_2$$

$$\text{i.e. } \mathbf{I}_1 / \mathbf{V}_2 = -\mathbf{h}_{12} / \mathbf{h}_{11}$$

Assuming the input excitations  $\mathbf{V}_1$  and  $\mathbf{V}_2$  to be the same, then the condition for the out responses  $\mathbf{I}_1$  and  $\mathbf{I}_2$  to be equal would be

$$\mathbf{I}_1 / \mathbf{V}_2 = \mathbf{I}_2 / \mathbf{V}_1$$

$$\text{i.e } = -\mathbf{h}_{12} / \mathbf{h}_{11} = \mathbf{h}_{21} / \mathbf{h}_{11}$$



$$\text{i.e.} \quad h_{12} = -h_{21}$$

And hence  $[h_{12} = -h_{21}]$  is the condition for the reciprocity in the Two port network with h parameter representation.

**Condition for symmetry:**

To get this condition we need to get expressions related to the input and output ports. In this case also it is easy to use the Z parameter definitions of  $Z_{11}$  and  $Z_{22}$  for the input and output ports respectively and get their values in terms of the h parameters as shown below.

$$\begin{aligned} \text{h parameter equations are :} \quad V_1 &= h_{11} \cdot I_1 + h_{12} \cdot V_2 \\ I_2 &= h_{21} \cdot I_1 + h_{22} \cdot V_2 \end{aligned}$$

First let us get  $Z_{11}$  :

$$Z_{11} = V_1 / I_1 \quad | \quad I_2 = 0$$

$$= h_{11} + h_{12} \cdot V_2 / I_1$$

Applying the condition  $I_2 = 0$  in the equation 2 we get

$$0 = h_{21} \cdot I_1 + h_{22} \cdot V_2 \quad \text{i.e.} \quad -h_{21} \cdot I_1 = h_{22} \cdot V_2$$

$$\text{or } V_2 = I_1 (-h_{21} / h_{22})$$

Now substituting the value of  $V_2 = I_1 (-h_{21} / h_{22})$  in the above first expression for  $V_1$  we get

$$V_1 = h_{11} \cdot I_1 + h_{12} \cdot I_1 \cdot (-h_{21} / h_{22})$$

$$\text{Or } V_1 / I_1 = (h_{11} \cdot h_{22} - h_{12} \cdot h_{21}) / h_{22} = \Delta h / h_{22}$$

$$\text{Or } Z_{11} = \Delta h / h_{22}$$

Where  $\Delta h = (h_{11} \cdot h_{22} - h_{12} \cdot h_{21})$

**Now let us get  $Z_{22}$  :**

$$Z_{22} = V_2 / I_2 \quad | \quad I_1 = 0$$

Applying the condition  $I_1 = 0$  in the second equation we get

$$I_2 = h_{21} \cdot 0 + h_{22} \cdot V_2 \quad \text{i.e.} \quad V_2 / I_2 = 1 / h_{22}$$

$$\text{And } Z_{22} = 1 / h_{22}$$

Hence the condition for symmetry  $Z_{11} = Z_{22}$  becomes  $(\Delta h / h_{22}) = (1 / h_{22})$  i.e  $\Delta h = 1$

**Hence  $\Delta h = 1$  is the condition for symmetry in h parameter representation.**

**Table: Summary of conditions for reciprocity and symmetry for Two port networks in terms of all four parameters.**

Parameter	Condition for reciprocity	Condition for symmetry
Z	$Z_{12} = Z_{21}$	$Z_{11} = Z_{22}$
Y	$Y_{12} = Y_{21}$	$Y_{11} = Y_{21}$
h	$h_{12} = -h_{21}$	$\Delta h = 1$
ABCD	$AD - BC = 1$	$A = D$

### Different types of interconnections of two port networks:

#### Series Connection:

Though here only two networks are considered, the result can be generalized for any number of two port networks connected in series.

Refer the figure below where two numbers of two port networks **A** and **B** are shown connected in series. All the input and output currents & voltages with directions and polarities are shown.

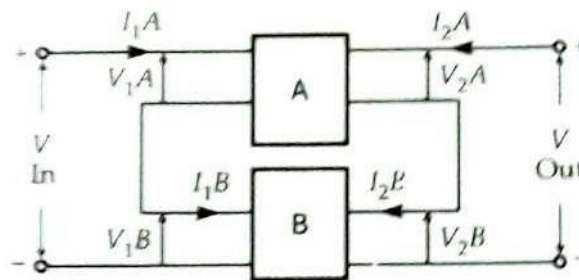


Fig : Series connection of two numbers of Two Port Networks

**Open circuit Impedance parameters ( Z )** are used in characterizing the Series connected Two port Networks .The governing equations with **Z** parameters are given below:

For network A :

$$V_{1A} = Z_{11A} I_{1A} + Z_{12A} I_{2A}$$

$$V_{2A} = Z_{21A} I_{1A} + Z_{22A} I_{2A}$$

And for network B:

$$V_{1B} = Z_{11B} I_{1B} + Z_{12B} I_{2B}$$

$$V_{2B} = Z_{21B} I_{1B} + Z_{22B} I_{2B}$$

Referring to the figure above the various voltage and current relations are:

$$I_1 \equiv I_{1A} \equiv I_{1B}$$

$$I_2 \equiv I_{2A} \equiv I_{2B}$$

$$V_2 = V_{2A} + V_{2B}$$

$$V_1 = V_{1A} + V_{1B}$$

Now substituting the above basic defining equations for the two networks into the above expressions for  $V_1$  and  $V_2$  and using the above current equalities we get:

$$\begin{aligned} V_1 &= V_{1A} + V_{1B} \\ &= (Z_{11A} I_{1A} + Z_{12A} I_{2A}) + Z_{11B} I_{1B} + Z_{12B} I_{2B} \\ &= I_1 (Z_{11A} + Z_{11B}) + I_2 (Z_{12A} + Z_{12B}) \end{aligned}$$

And similarly

$$\begin{aligned} V_2 &= V_{2A} + V_{2B} \\ &= (Z_{21A} I_{1A} + Z_{22A} I_{2A}) + (Z_{21B} I_{1B} + Z_{22B} I_{2B}) \\ V_2 &= I_1 (Z_{21A} + Z_{21B}) + I_2 (Z_{22A} + Z_{22B}) \end{aligned}$$

Thus we get for two numbers of series connected two port networks:

$$V_1 = (Z_{11A} + Z_{11B}) I_1 + (Z_{12A} + Z_{12B}) I_2$$

$$V_2 = (Z_{21A} + Z_{21B}) I_1 + (Z_{22A} + Z_{22B}) I_2$$

Or in matrix form:

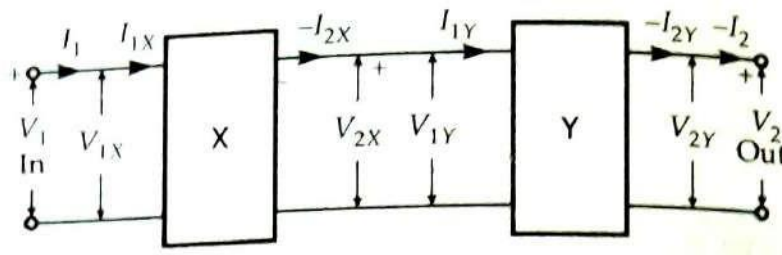
$$\begin{bmatrix} V_1 \\ V_2 \end{bmatrix} = \begin{bmatrix} Z_{11A} + Z_{11B} & Z_{12A} + Z_{12B} \\ Z_{21A} + Z_{21B} & Z_{22A} + Z_{22B} \end{bmatrix} \begin{bmatrix} I_1 \\ I_2 \end{bmatrix}$$

**Thus it can be seen that the Z parameters for the series connected two port networks are the sum of the Z parameters of the individual two port networks.**

#### Cascade connection:

In this case also though here only two networks are considered, the result can be generalized for any number of two port networks connected in cascade.

Refer the figure below where two numbers of two port networks X and Y are shown connected in cascade. All the input and output currents & voltages with directions and polarities are shown.



**Fig: Two numbers of two port networks connected in cascade**

**Transmission ( ABCD ) parameters** are easily used in characterizing the cascade connected Two port Networks .The governing equations with transmission parameters are given below:

For network X:

$$\begin{aligned} V_{1X} &= A_X V_{2X} - B_X I_{2X} \\ I_{1X} &= C_X V_{2X} - D_X I_{2X} \end{aligned}$$

And for network Y:

$$\begin{aligned} V_{1Y} &= A_Y V_{2Y} - B_Y I_{2Y} \\ I_{1Y} &= C_Y V_{2Y} - D_Y I_{2Y} \end{aligned}$$

Referring to the figure above the various voltage and current relations are:

$$\begin{aligned} I_1 &= I_{1X} ; -I_{2X} = I_{1Y} ; I_2 = I_{2Y} \\ V_1 &= V_{1X} ; V_{2X} = V_{1Y} ; V_2 = V_{2Y} \end{aligned}$$

Then the overall transmission parameters for the cascaded network in matrix form will become

$$\begin{aligned} \begin{bmatrix} V_1 \\ I_1 \end{bmatrix} &= \begin{bmatrix} V_{1X} \\ I_{1X} \end{bmatrix} = \begin{bmatrix} A_X & B_X \\ C_X & D_X \end{bmatrix} \begin{bmatrix} V_{2X} \\ -I_{2X} \end{bmatrix} \\ &= \begin{bmatrix} A_X & B_X \\ C_X & D_X \end{bmatrix} \begin{bmatrix} V_{1Y} \\ I_{1Y} \end{bmatrix} \\ &= \begin{bmatrix} A_X & B_X \\ C_X & D_X \end{bmatrix} \begin{bmatrix} A_Y & B_Y \\ C_Y & D_Y \end{bmatrix} \begin{bmatrix} V_{2Y} \\ -I_{2Y} \end{bmatrix} \\ &= \begin{bmatrix} A_X & B_X \\ C_X & D_X \end{bmatrix} \begin{bmatrix} A_Y & B_Y \\ C_Y & D_Y \end{bmatrix} \begin{bmatrix} V_Y \\ -I_Y \end{bmatrix} \\ &= \begin{bmatrix} A & B \\ C & D \end{bmatrix} \begin{bmatrix} V_Y \\ -I_Y \end{bmatrix} \end{aligned}$$

Where

$$\begin{bmatrix} A & B \\ C & D \end{bmatrix} = \begin{bmatrix} A_X & B_X \\ C_X & D_X \end{bmatrix} \begin{bmatrix} A_Y & B_Y \\ C_Y & D_Y \end{bmatrix}$$

**Thus it can be seen that the overall ABCD Parameter matrix of cascaded two Port Networks is the product of the ABCD matrices of the individual networks.**

**Parallel Connection:**

Though here only two networks are considered, the result can be generalized for any number of two port networks connected in parallel.

Refer the figure below where two numbers of two port networks **A** and **B** are shown connected in parallel. All the input and output currents & voltages with directions and polarities are shown.

.

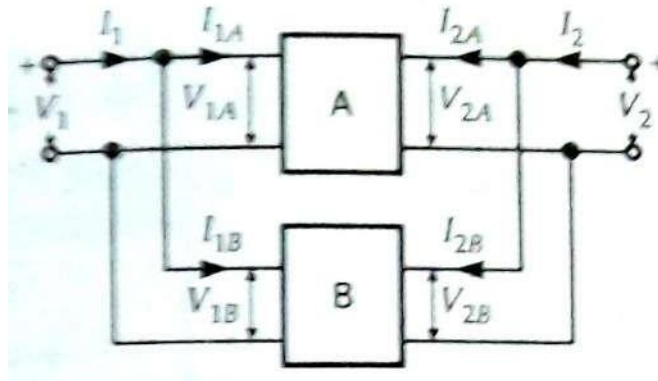


Fig: Parallel connection of two numbers of Two Port Networks

**Short circuit admittance (Y) parameters** are easily used in characterizing the parallel connected Two port Networks .The governing equations with Y parameters are given below:

For network A:

$$I_{1A} = Y_{11A} V_{1A} + Y_{12A} V_{2A}$$

$$I_{2A} = Y_{21A} V_{1A} + Y_{22A} V_{2A}$$

And for network B:

$$I_{1B} = Y_{11B} V_{1B} + Y_{12B} V_{2B}$$

$$I_{2B} = Y_{21B} V_{1B} + Y_{22B} V_{2B}$$

Referring to the figure above the various voltage and current relations are:

$$V_1 = V_{1A} = V_{1B}; V_2 = V_{2A} = V_{2B}$$

$$I_1 = I_{1A} + I_{1B}; I_2 = I_{2A} + I_{2B}$$

Thus

$$\begin{aligned} I_1 &= I_{1A} + I_{1B} \\ &= (Y_{11A} V_{1A} + Y_{12A} V_{2A}) + (Y_{11B} V_{1B} + Y_{12B} V_{2B}) \\ &= (Y_{11A} + Y_{11B}) V_1 + (Y_{12A} + Y_{12B}) V_2 \\ I_2 &= I_{2A} + I_{2B} \\ &= (Y_{21A} V_{1A} + Y_{22A} V_{2A}) + (Y_{21B} V_{1B} + Y_{22B} V_{2B}) \\ &= (Y_{21A} + Y_{21B}) V_1 + (Y_{22A} + Y_{22B}) V_2 \end{aligned}$$

Thus we finally obtain the Y parameter equations for the combined network as:

$$I_1 = (Y_{11A} + Y_{11B}) V_1 + (Y_{12A} + Y_{12B}) V_2$$

$$I_2 = (Y_{21A} + Y_{21B}) V_1 + (Y_{22A} + Y_{22B}) V_2$$

And in matrix notation it will be:

$$\begin{bmatrix} I_1 \\ I_2 \end{bmatrix} = \begin{bmatrix} Y_{11A} + Y_{11B} & Y_{12A} + Y_{12B} \\ Y_{21A} + Y_{21B} & Y_{22A} + Y_{22B} \end{bmatrix} \begin{bmatrix} V_1 \\ V_2 \end{bmatrix}$$

**Thus it can be seen that the overall Y parameters for the parallel connected two port networks are the sum of the Y parameters of the individual two port networks.**

### Image impedances in terms of ABCD parameters:

Image impedances  $Z_{i1}$  and  $Z_{i2}$  of a two port network as shown in the figure below are defined as two values of impedances such that :

- When port two is terminated with an impedance  $Z_{i2}$ , the input impedance as seen from Port one is  $Z_{i1}$  and
- When port one is terminated with an impedance  $Z_{i1}$ , the input impedance as seen from Port two is  $Z_{i2}$

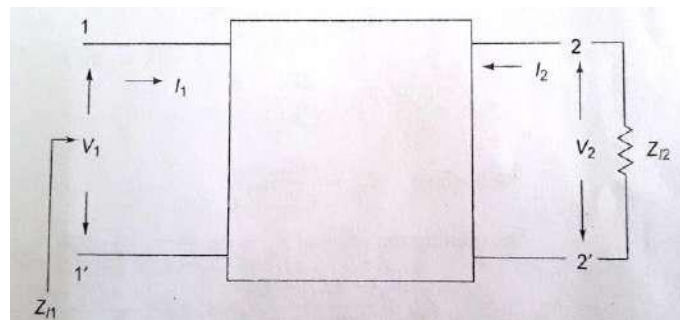


Figure pertaining to condition (a) above

Corresponding Relations are :  $Z_{i1} = V_1 / I_1$  and  $Z_{i2} = V_2 / -I_2$

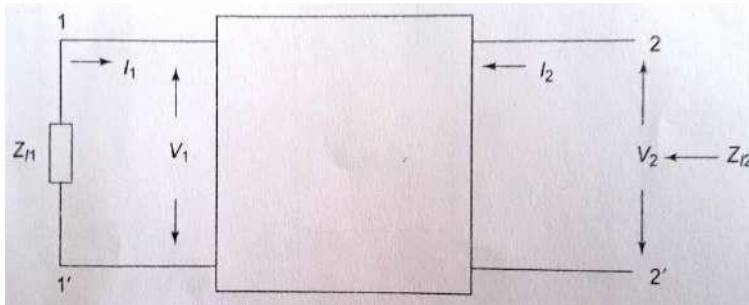


Figure pertaining to condition (b) above

Corresponding Relations are :  $Z_{i1} = V_1 / -I_1$  and  $Z_{i2} = V_2 / I_2$

Such Image impedances in terms of ABCD parameters for a two port network are obtained below:

The basic defining equations for a two port network with ABCD parameters are :

$$V_1 = A.V_2 - B.I_2$$

$$I_1 = C.V_2 - D.I_2$$

First let us consider condition (a).

Dividing the first equation with the second equation we get

$$Z_{i1} = \frac{V_1}{I_1} = \frac{AV_2 - BI_2}{CV_2 - DI_2}$$

But we also have  $Z_{i2} = V_2 / -I_2$  and so  $V_2 = -Z_{i2} I_2$ . Substituting this value of  $V_2$  in the above we get

$$Z_{i1} = \frac{-AZ_{i2} - B}{-CZ_{i2} - D} = \frac{AZ_{i2} + B}{CZ_{i2} + D}$$

Now let us consider the condition (b):

The basic governing equations  $[V_1 = A.V_2 - B.I_2]$  and  $[I_1 = C.V_2 - D.I_2]$  are manipulated to get

$$V_2 = \frac{DV_1}{AD - BC} - \frac{BI_1}{AD - BC}$$

$$I_2 = \frac{CV_1}{AD - BC} - \frac{AI_1}{AD - BC}$$

$$Z_{i2} = \frac{V_2}{I_2} = \frac{DV_1 - BI_1}{CV_1 - AI_1}$$

But we also have  $Z_{i1} = V_1 / -I_1$  and so  $V_1 = -Z_{i1} I_1$ . Substituting this value of  $V_1$  in the above we get :

$$Z_{i2} = \frac{DZ_{i1} + B}{CZ_{i1} + A}$$

Solving the above equations for  $Z_{i1}$  and  $Z_{i2}$  we get :

$$Z_{i1} = \sqrt{\frac{AB}{CD}}; \quad Z_{i2} = \sqrt{\frac{BD}{AC}}$$

### Important formulae, Equations and Relations:

- **Basic Governing equations in terms of the various Parameters:**
  - **Z Parameters :**  $V_1 = Z_{11}I_1 + Z_{12}I_2$   
 $V_2 = Z_{21}I_1 + Z_{22}I_2$
  - **Y Parameters:**  $I_1 = Y_{11}V_1 + Y_{12}V_2$   
 $I_2 = Y_{21}V_1 + Y_{22}V_2$
  - **h Parameters :**  $V_1 = h_{11} \cdot I_1 + h_{12} \cdot V_2$   
 $I_2 = h_{21} \cdot I_1 + h_{22} \cdot V_2$
  - **ABCD Parameters:**  $V_1 = A \cdot V_2 - B \cdot I_2$   
 $I_1 = C \cdot V_2 - D \cdot I_2$
- **Conditions for Reciprocity and symmetry for Two Port Networks in terms of the various parameters :**

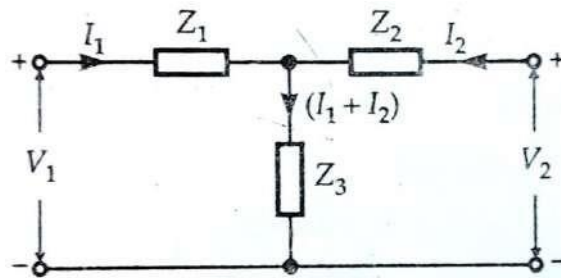
Parameter	Condition for reciprocity	Condition for symmetry
Z	$Z_{12} = Z_{21}$	$Z_{11} = Z_{22}$
Y	$Y_{12} = Y_{21}$	$Y_{11} = Y_{21}$
h	$h_{12} = -h_{21}$	$\Delta h = 1$
ABCD	$AD - BC = 1$	$A = D$

- **Relations of Interconnected two port Networks :**
  - *The overall Z parameters for the series connected two port networks are the sum of the Z parameters of the individual two port networks.*
  - *The overall Y parameters for the parallel connected two port networks are the sum of the Y parameters of the individual two port networks.*
  - *The overall ABCD Parameter matrix of cascaded two Port Networks is the product of the ABCD matrices of the individual networks.*



**Illustrative problems :**

**Example 1:** Find the Z Parameters of the following Two Port Network and draw its equivalent circuit in terms of  $Z_1$ ,  $Z_2$  and  $Z_3$ .



**Solution:** Applying KVL to the above circuit in the two loops, with the current notation as shown, the loop equations for  $V_1$  and  $V_2$  can be written as :

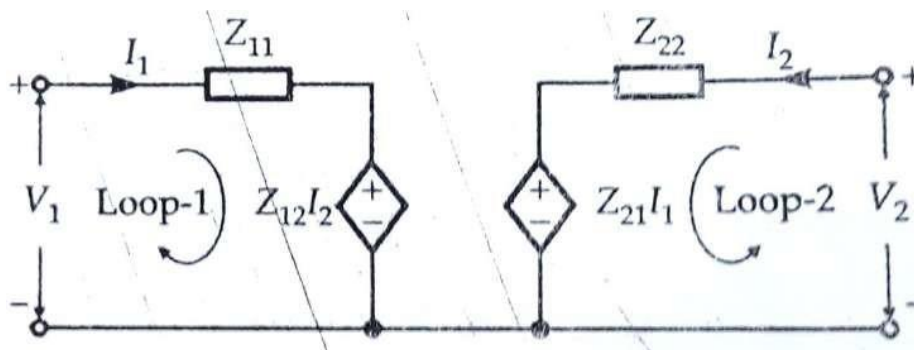
$$\begin{aligned} V_1 &= I_1 Z_1 + (I_1 + I_2) Z_3 \\ \text{or} \quad V_1 &= (Z_1 + Z_3) I_1 + Z_3 I_2 \quad \dots(i) \\ \text{and} \quad V_2 &= I_2 Z_2 + (I_2 + I_1) Z_3 \\ \text{or} \quad V_2 &= Z_3 I_1 + (Z_2 + Z_3) I_2 \quad \dots(ii) \end{aligned}$$

Comparing the equations (i) and (ii) above with the standard expressions for the Z parameter equations we get :

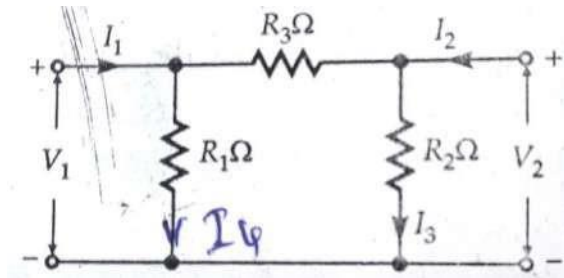
$$Z_{11} = Z_1 + Z_3; Z_{12} = Z_3;$$

$$Z_{21} = Z_3; Z_{22} = Z_2 + Z_3$$

Equivalent circuit in terms of  $Z_1$ ,  $Z_2$  and  $Z_3$  is shown below.



**Example 2:** Determine the Z parameters of the  $\pi$  type two port network shown in the figure below.



Solution:

From the basic Z parameter equations We know that

$$Z_{11} = V_1/I_1 \quad | \quad I_2=0$$

$$Z_{12} = V_1/I_2 \quad | \quad I_1=0$$

$$Z_{21} = V_2/I_1 \quad | \quad I_2=0$$

$$Z_{22} = V_2/I_2 \quad | \quad I_1=0$$

We will first find out  $Z_{11}$  and  $Z_{21}$  which are given by the common condition  $I_2 = 0$

1. We can observe that  $Z_{11} = V_1/I_1$  with  $I_2=0$  is the parallel combination of  $R_1$  and  $(R_2 + R_3)$ .

$$\therefore Z_{11} = R_1 (R_2 + R_3) / (R_1 + R_2 + R_3)$$

2.  $Z_{21} = V_2/I_1 \quad | \quad I_2=0$

By observing the network we find that the current  $I_1$  is dividing into  $I_3$  and  $I_4$  as shown in the figure where  $I_3$  is flowing through  $R_2$  (and  $R_3$  also since  $I_2=0$ )

$$\text{Hence } V_2 = I_3 \times R_2$$

From the principle of current division we find that  $I_3 = I_1 \cdot R_1 / (R_1 + R_2 + R_3)$

$$\text{Hence } V_2 = I_3 \times R_2 = [ I_1 \cdot R_1 / (R_1 + R_2 + R_3) ] \cdot R_2 = I_1 \cdot R_1 R_2 / (R_1 + R_2 + R_3)$$

$$\text{And } V_2/I_1 = R_1 R_2 / (R_1 + R_2 + R_3)$$

$$\therefore Z_{21} = R_1 R_2 / (R_1 + R_2 + R_3)$$

Next we will find out  $Z_{12}$  and  $Z_{22}$  which are given by the common condition  $I_1 = 0$

3.  $Z_{12} = V_1/I_2 \quad | \quad I_1=0$

By observing the network we find that the current  $I_2$  is now dividing into  $I_3$  and  $I_4$  as shown in the figure where  $I_4$  is flowing through  $R_1$  ( and  $R_3$  also since  $I_1 = 0$  )

$$\text{Hence } V_1 = I_4 \times R_1$$

Again from the principle of current division we find that  $I_4 = I_2 \cdot R_2 / (R_1 + R_2 + R_3)$

$$\text{Hence } V_1 = I_4 \times R_1 = [ I_2 \cdot R_2 / (R_1 + R_2 + R_3) ] \cdot R_1 = I_2 \cdot R_1 R_2 / (R_1 + R_2 + R_3)$$

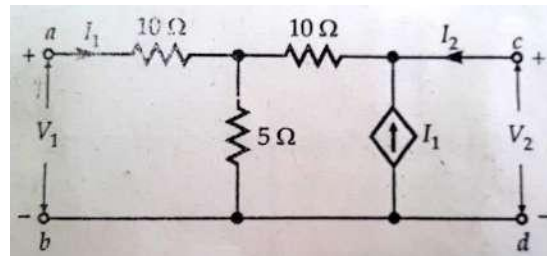
$$\text{And } V_1/I_2 = R_1 R_2 / (R_1 + R_2 + R_3)$$

$$\therefore Z_{12} = R_1 R_2 / (R_1 + R_2 + R_3)$$

4. We can again observe that  $Z_{22} = V_2/I_2$  with  $I_1=0$  is the parallel combination of  $R_2$  and  $(R_1 + R_3)$

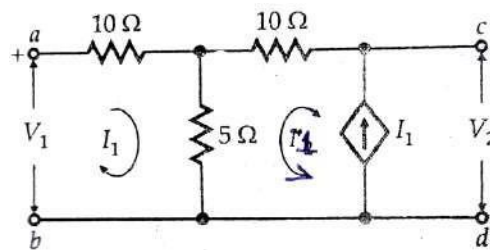
$$\therefore Z_{22} = R_2 (R_1 + R_3) / (R_1 + R_2 + R_3)$$

**Example 3 :** Determine the Z parameters of the network shown in the figure below.



**1). We will first find out  $Z_{11}$  and  $Z_{21}$  which are given by the common condition  $I_2 = 0$  (Output open circuited)**

With this condition the circuit is redrawn as shown below.



Since the current source is there in the second loop which is equal to  $I_1$  and  $I_2$  is zero, only current  $I_1$  flows through the right hand side resistance of  $10\Omega$  and both currents  $I_1$  ( both loop currents ) pass through the resistance of  $5\Omega$  as shown in the redrawn figure .

Now the equation for loop one is given by :

$$V_1 = 10 \times I_1 + 5 ( 2 I_1 ) = 20 I_1 \quad \text{and} \quad V_1/I_1 = 20\Omega$$

$$\therefore V_1/I_1 \big|_{I_2=0} = Z_{11} = 20\Omega$$

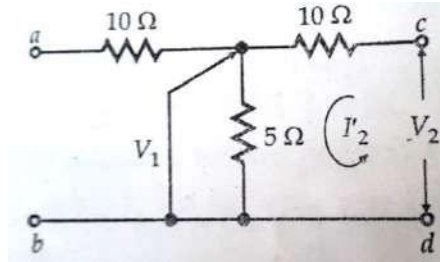
Next the equation for loop two is given by :

$$V_2 = 10 \times I_1 + 5 ( 2 I_1 ) = 20 I_1 \quad \text{and} \quad V_2/I_1 = 20\Omega$$

$$\therefore V_2/I_1 \big|_{I_2=0} = Z_{21} = 20\Omega$$

**2). Next we will find out  $Z_{12}$  and  $Z_{22}$  which are given by the common condition  $I_1 = 0$  (input open circuited)**

With this condition the circuit is redrawn as shown below.



Now since the current  $I_1$  is zero, the current source of  $I_1$  would no longer be there in the output loop and it is removed as shown in the redrawn figure. Further since input current  $I_1 = 0$ , there would be no current in the input side  $10\Omega$  and the same current  $I_2$  only flows through common resistance of  $5\Omega$  and output side resistance of  $10\Omega$ . With these conditions incorporated, now we shall rewrite the two loop equations ( for input  $V_1$  and output  $V_2$  ) to get  **$Z_{12}$  and  $Z_{22}$**   
Equation for loop one is given by :

$$V_1 = 5 I_2 \text{ and } V_1/I_2 = 5\Omega$$

$$\therefore V_1/I_2 \big|_{I_1=0} = Z_{12} = 5\Omega$$

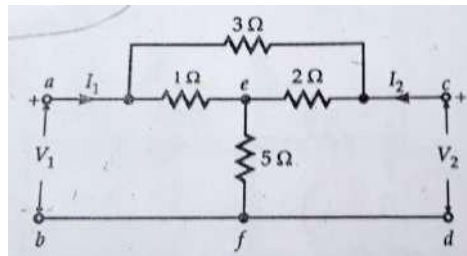
And the equation for loop two is given by:

$$V_2 = 10 \times I_2 + 5 \times I_2 = 15 I_2 \text{ and } V_2/I_2 = 15\Omega$$

$$\therefore V_2/I_2 \big|_{I_1=0} = Z_{22} = 15\Omega$$

**Finally:**  $Z_{11} = 20\Omega$  ;  $Z_{12} = 5\Omega$  ;  $Z_{21} = 20\Omega$  ;  $Z_{22} = 15\Omega$

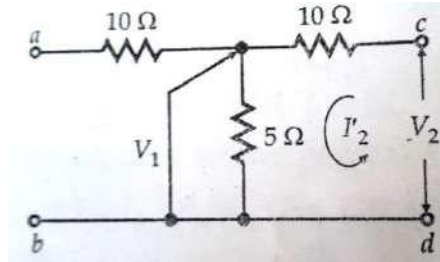
**Example 4:** Obtain the open circuit parameters of the Bridged T network shown in the figure below.



Open circuit parameters are same as Z parameters.

**1). We will first find out  $Z_{11}$  and  $Z_{21}$  which are given by the common condition  $I_2 = 0$  (Output open circuited)**

With this condition the circuit is redrawn as shown below.



From the inspection of the figure in this condition it can be seen that ( since  $I_2$  is zero ) the two resistances i.e the bridged arm of  $3\Omega$  and output side resistance of  $2\Omega$  are in series and together are in parallel with the input side resistance of  $1\Omega$ .

Hence the loop equation for  $V_1$  can be written as:

$$V_1 = I_1 \times [(3+2) \parallel 1 + 5] = I_1 \times 35/6 \text{ and } V_1/I_1 = 35/6$$

$$\therefore V_1/I_1 \mid I_2=0 = Z_{11} = 35/6\Omega$$

Next the loop equation for  $V_2$  can be written as :

$$V_2 = I_3 \times 2 + I_1 \times 5$$

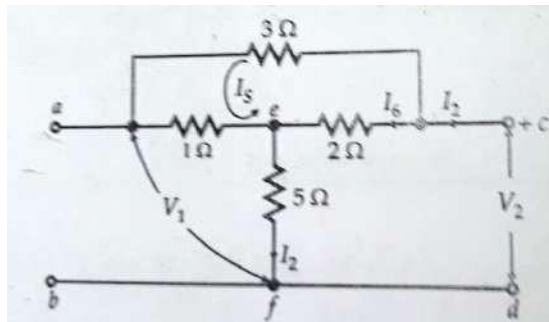
But we know from the principle of current division that the current  $I_3 = I_1 \times [1/(1+2+3)] = I_1 \times 1/6$

Hence  $V_2 = I_1 \times 1/6 \times 2 + I_1 \times 5 = I_1 \times 16/3$  and  $V_2 / I_1 = 16/3 \Omega$

$$\therefore V_2/I_1 \mid I_2=0 = Z_{21} = 16/3 \Omega$$

**2). Next we will find out  $Z_{12}$  and  $Z_{22}$  which are given by the common condition  $I_1 = 0$  (input open circuited)**

With this condition the circuit is redrawn as shown below.



From the inspection of the figure in this condition it can be seen that ( since  $I_1$  is zero ) the two resistances i.e the bridged arm of  $3\Omega$  and input side resistance of  $1\Omega$  are in series and together are in parallel with the output side resistance of  $2\Omega$ . Further  $I_2 = I_5 + I_6$

Hence the loop equation for  $V_1$  can be written as :

$$V_1 = I_5 \times 1 + I_2 \times 5$$

But we know from the principle of current division that the current  $I_5 = I_2 \times [2/(1+2+3)] = I_2 \times 1/3$

Hence  $V_1 = I_2 \times 1/3 \times 1 + I_2 \times 5 = I_2 \times 16/3$  and  $V_1 / I_2 = 16/3 \Omega$

$$\therefore V_1/I_2 \mid I_1=0 = Z_{12} = 16/3 \Omega$$

Next the loop equation for  $V_2$  can be written as:

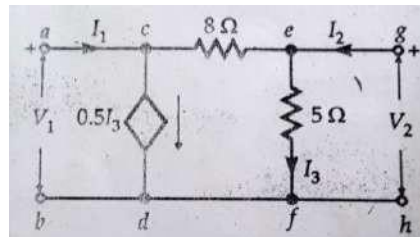
$$V_2 = I_6 \times 2 + I_2 \times 5$$

But we know from the principle of current division that the current  $I_6 = I_2 \times [1/(1+2+3)] = I_2 \times (3+1)/6 = (I_2 \times 2/3)$

Hence  $V_2 = I_2 \times (2/3) \times 2 + I_2 \times 5 = I_2 \times 19/3$  and  $V_2/I_2 = 19/3$

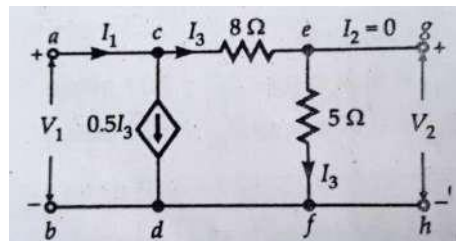
$$\therefore V_2/I_2 \big|_{I_2=0} = Z_{22} = 19/3 \Omega$$

**Example 5 :** Obtain Z parameters of the following  $\pi$  network with a controlled current source of  $0.5 I_3$  in the input port.



**1). We will first find out  $Z_{11}$  and  $Z_{21}$  which are given by the common condition  $I_2 = 0$  (Output open circuited)**

With this condition the circuit is redrawn as shown below.



In this condition we shall first apply Kirchhoff's current law to the node 'c':

Then  $I_1 = 0.5I_3 + I_3$  ( $I_3$  being the current through the resistances of  $8 \Omega$  and  $5 \Omega$ )

i.e.  $I_1 = 0.5I_3 + I_3$  or  $I_1 = 1.5I_3$  or  $I_3 = I_1/1.5$  i.e.  $I_3 = (2/3)I_1$

Now we also observe that  $V_1 = I_3(8+5) = 13 \cdot I_3$

Using the value of  $I_3 = (2/3)I_1$  into the above expression we get

$$V_1 = 13(2/3)I_1 \quad \text{and} \quad V_1/I_1 = 26/3 = 8.67$$

$$\therefore V_1/I_1 \big|_{I_2=0} = Z_{11} = 8.67 \Omega$$

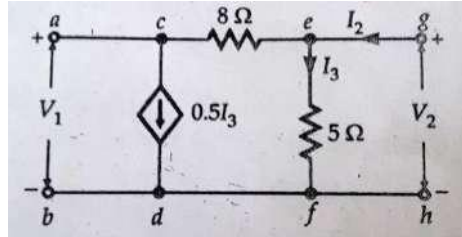
Next we also observe that  $V_2 = 5 \cdot I_3$  and substituting the above value of  $I_3 = (2/3)I_1$  into this expression for  $V_2$  we get :

$$V_2 = 5 \cdot I_3 \text{ i.e. } V_2 = 5 \cdot (2/3)I_1 \text{ i.e. } V_2/I_1 = 10/3 = 3.33 \Omega$$

$$\therefore V_2/I_1 \big|_{I_2=0} = Z_{21} = 3.33 \Omega$$

2). Next we will find out  $Z_{12}$  and  $Z_{22}$  which are given by the common condition  $I_1 = 0$  (input open circuited)

With this condition the circuit is redrawn as shown below.



In this condition now we shall first apply Kirchoff's current law to the node 'e':

Then  $I_2 = 0.5I_3 + I_3$  (  $0.5I_3$  being the current through the resistance of  $8 \Omega$  and  $I_3$  being the current through the resistances of  $5 \Omega$  )

i.e  $I_2 = 0.5I_3 + I_3$  or  $I_2 = 1.5I_3$  or  $I_3 = I_2/1.5$  i.e  $I_3 = (2/3)I_2$

Now we also observe that  $V_1 = (-0.5I_3 \times 8 + I_3 \times 5) = I_3$  ( it is to be noted here carefully that – sign is to be taken before  $0.5I_3 \times 8$  since the current flows through the resistance of  $8 \Omega$  now in the reverse direction.

Using the value of  $I_3 = (2/3)I_2$  into the above expression for  $V_1$  we get

$V_1 = (2/3)I_2$  and  $V_1/I_2 = 0.67$

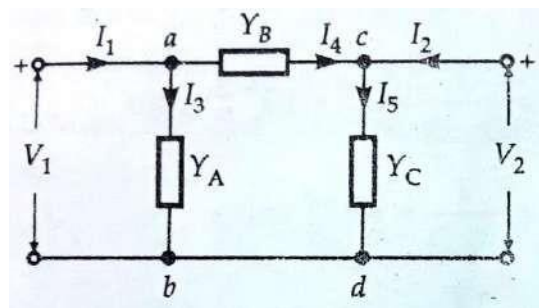
$$\therefore V_1/I_2 \mid I_1=0 = Z_{12} = 0.67\Omega$$

Next we also observe that  $V_2 = 5 \cdot I_3$  and substituting the above value of  $I_3 = (2/3)I_2$  into this expression for  $V_2$  we get :

$V_2 = 5 \cdot I_3$  i.e  $V_2 = 5 \cdot (2/3)I_2$  i.e  $V_2/I_2 = 10/3 = 3.33\Omega$

$$\therefore V_2/I_2 \mid I_1=0 = Z_{21} = 3.33 \Omega$$

**Example 6 :** Find the Y parameters of the following  $\pi$  type two port network and draw it's Y parameter equivalent circuit in terms of the given circuit parameters.



Applying KCL at node (a) we get

$$I_1 = I_3 + I_4$$

$$I_1 = V_1 Y_A + (V_1 - V_2) Y_B$$

$$I_1 = V_1 (Y_A + Y_B) + (-Y_B) V_2 \quad \dots (i)$$

Similarly applying KCL to node (c) we get

$$I_2 = I_5 - I_4$$

$$I_2 = V_2 Y_C - (V_1 - V_2) Y_B$$

$$I_2 = (-Y_B) V_1 + (Y_C + Y_B) V_2 \quad \dots (ii)$$

Comparing the equations (i) and (ii) above with the standard expressions for the Y parameter equations we get :

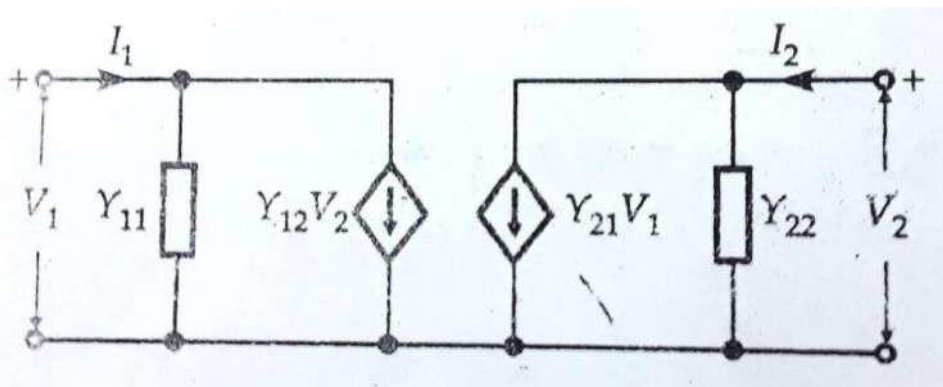
$$Y_{11} = (Y_A + Y_B); Y_{12} = -Y_B$$

$$Y_{21} = -Y_B; Y_{22} = Y_C + Y_B.$$

Observing the equations (i) and (ii) above we find that :

- The terms  $V_1 (Y_A + Y_B)$  and  $V_2 (Y_C + Y_B)$  are the currents through the admittances  $Y_{11}$  and  $Y_{22}$  and
- The terms  $-Y_B \cdot V_2$  and  $-Y_B \cdot V_1$  are the dependent current sources in the input and the output ports respectively.

These observations are reflected in the equivalent circuit shown below.

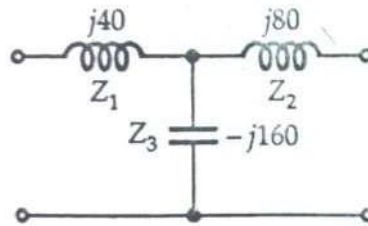


In the above figure  $Y_{11} = (Y_A + Y_B)$  &  $Y_{22} = (Y_C + Y_B)$  are the admittances and

$Y_{12} \cdot V_2 = -Y_B \cdot V_2$  &  $Y_{21} \cdot V_1 = -Y_B \cdot V_1$  are the dependent current sources



**Example 7: Find the Y parameters of the following network**



**Solution:** We will solve this problem in two steps.

1. We shall first express the Z parameters of the given T network in terms of the impedances  $Z_1$ ,  $Z_2$  and  $Z_3$  using the standard formulas we already know and substitute the given values of  $Z_1$ ,  $Z_2$  and  $Z_3$ .

$$\begin{aligned} Z_{11} &= Z_1 + Z_3 = -j 120 ; \\ Z_{12} &= Z_3 = -j 160 \\ Z_{21} &= Z_3 = -j 160 ; \\ Z_{22} &= Z_2 + Z_3 = -j 80 \end{aligned}$$

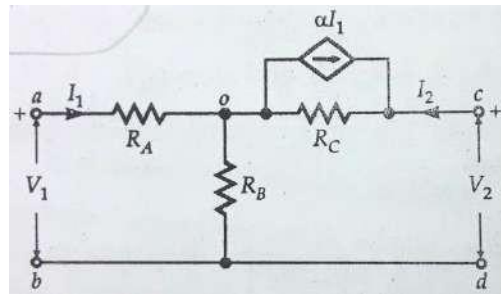
2. Then convert the values of the Z parameters into Y parameters i.e express the Y parameters in terms of Z parameters using again the standard relationships.

$$\begin{aligned} Y_{11} &= \frac{Z_{22}}{Z_{11}Z_{22} - Z_{12}Z_{21}} \\ &= \frac{-j 80}{(-j 120)(-j 80) - (-j 160)^2} \\ &= \frac{-j 80}{16,000} = \frac{-j}{200} \text{ mho.} \end{aligned}$$

$$\begin{aligned} Y_{12} = Y_{21} &= \frac{-Z_{12}}{Z_{11}Z_{22} - Z_{12}Z_{21}} \\ &= \frac{j 160}{16,000} = \frac{j}{100} \text{ mho.} \end{aligned}$$

$$\begin{aligned} Y_{22} &= \frac{Z_{11}}{Z_{11}Z_{22} - Z_{12}Z_{21}} \\ &= \frac{-j 120}{16,000} = \frac{-j}{133.33} \text{ mho.} \end{aligned}$$

**Example 8:** Find the 'h' parameters of the network shown below. (fig12.34)



First let us write down the basic 'h' parameter equations and give the definitions of the 'h' parameters.

$$V_1 = h_{11} \cdot I_1 + h_{12} \cdot V_2$$

$$I_2 = h_{21} \cdot I_1 + h_{22} \cdot V_2$$

$$h_{11} = V_1/I_1 \quad \text{with } V_2 = 0$$

$$h_{21} = I_2/I_1 \quad \text{with } V_2 = 0$$

$$h_{12} = V_1/V_2 \quad \text{with } I_1 = 0$$

$$h_{22} = I_2/V_2 \quad \text{with } I_1 = 0$$

Now

**1). We will first find out  $h_{11}$  and  $h_{21}$  which are given by the common condition  $V_2 = 0$  (Output short circuited)**

In this condition it can be observed that the resistance  $R_C$  and the current source  $\alpha I_1$  become parallel with resistance  $R_B$ .

For convenience let us introduce a temporary variable  $V$  as the voltage at the node 'o'. Then the current through the parallel combination of  $R_B$  and  $R_C$  would be equal to

$$\frac{V}{\frac{R_B R_C}{R_B + R_C}} = \frac{V(R_B + R_C)}{R_B R_C}$$

Then applying KCL at the node 'o' we get

$$I_1 = \frac{V(R_B + R_C)}{R_B R_C} + \alpha I_1$$

$$I_1 (1 - \alpha) = \frac{V(R_B + R_C)}{R_B R_C}$$

$$\therefore V = \frac{(1 - \alpha) I_1 R_B R_C}{(R_B + R_C)}$$

Next applying KVL at input port we get  $V_1 = I_1 \cdot R_A + V$  and  $V_1 / I_1 = R_A + V / I_1$

Now using the value of  $V$  we obtained above in this expression for  $V_1 / I_1$  we get

$$h_{11} = \frac{V_1}{I_1} = R_A + \frac{(1-\alpha) R_B R_C}{R_B + R_C}$$

$$= \frac{R_A (R_B + R_C) + (1-\alpha) R_B R_C}{R_B + R_C} \text{ ohm.}$$

Again from inspection of the figure above it is evident that

$$I_2 = - \left( \alpha I_1 + \frac{V}{R_C} \right)$$

$$I_2 = -\alpha I_1 - \frac{(1-\alpha) I_1 R_B}{(R_B + R_C)}$$

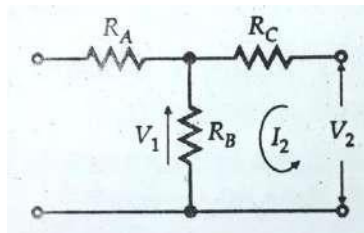
Therefore

$$h_{21} = \frac{I_2}{I_1} \Big|_{V_2=0} = -\alpha - \frac{(1-\alpha) R_B}{(R_B + R_C)}$$

$$= -\frac{(\alpha R_C + R_B)}{(R_B + R_C)}$$

**2). Next we will find out  $h_{12}$  and  $h_{22}$  which are given by the common condition  $I_1 = 0$  (Input open circuited)**

Now since  $I_1$  is zero, the current source disappears and the circuit becomes simpler as shown in the figure below.



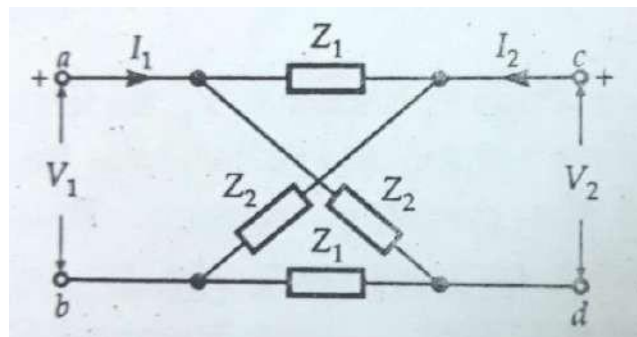
Now applying KVL at the output port we get:

$$V_2 = I_2 (R_B + R_C)$$
$$\left. \frac{I_2}{V_2} \right|_{I_1=0} = h_{22} = \left( \frac{1}{R_B + R_C} \right) \text{ mho.}$$

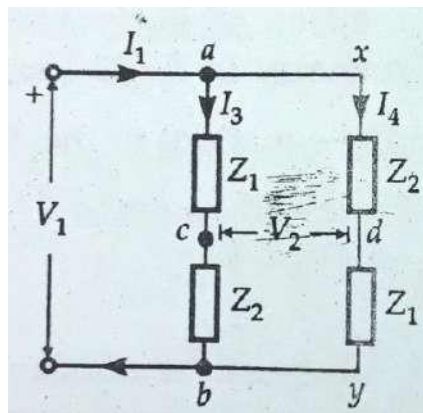
Again under this condition:

$$V_1 = I_2 R_B$$
$$\therefore h_{12} = \left. \frac{V_1}{V_2} \right|_{I_1=0} = \frac{I_2 R_B}{I_2 (R_B + R_C)}$$
$$= \frac{R_B}{R_B + R_C}.$$

**Example 9 :** Z parameters of the lattice network shown in the figure below.



First we shall redraw the given lattice network in a simpler form for easy analysis as shown below.



**We will then find out  $Z_{11}$  and  $Z_{21}$  which are given by the common condition  $I_2 = 0$  (Output open circuited)**

It can be observed that the impedances in the two arms 'ab' and 'xy' are same i.e  $Z_1 + Z_2$  and their parallel combination is  $(Z_1 + Z_2)/2$

Hence applying KVL at the input port we get

$$V_1 = I_1 \left( \frac{Z_1 + Z_2}{2} \right)$$

$$\frac{V_1}{I_1} = Z_{11} \Big|_{I_2=0} = \frac{Z_1 + Z_2}{2}$$

Next we find that

$$V_2 = V_c - V_d = (V_1 - I_3 Z_1) - (V_1 - I_4 Z_2)$$

$$= I_4 Z_2 - I_3 Z_1$$

( $V_c$  and  $V_d$  being the potentials at points 'c' and 'd')

It can also be observed from the simplified circuit that the currents  $I_3$  and  $I_4$  through the branches 'ab' and 'xy' are equal since the branch impedances are same and same voltage  $V_1$  is applied across both the branches. Hence the current  $I$  divides equally as  $I_3$  and  $I_4$

i.e  $I_3 = I_4 = I/2$

Now substituting these values of  $I_3$  and  $I_4$  in the expression for  $V_2$  above:

$$V_2 = \frac{I_1}{2} \times Z_2 - \frac{I_1}{2} \times Z_1 = \frac{Z_2 - Z_1}{2} \cdot I_1$$

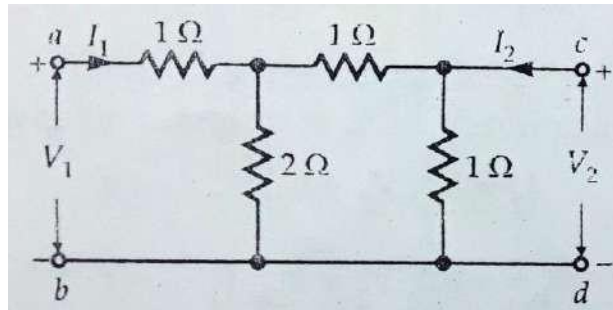
$$\frac{V_2}{I_1} = Z_{21} \Big|_{I_2=0} = \frac{Z_2 - Z_1}{2}$$

As can be seen the circuit is both symmetrical and Reciprocal and hence :

$$Z_{11} = Z_{22} = \frac{Z_1 + Z_2}{2}$$

$$Z_{12} = Z_{21} = \frac{Z_2 - Z_1}{2}$$

**Example 10:** Find the transmission parameters of the following network (fig 12.51)



First let us write down the basic ABCD parameter equations and give their definitions.

$$V_1 = A.V_2 - B.I_2$$

$$I_1 = C.V_2 - D.I_2$$

$$A = V_1/V_2 \text{ with } I_2 = 0$$

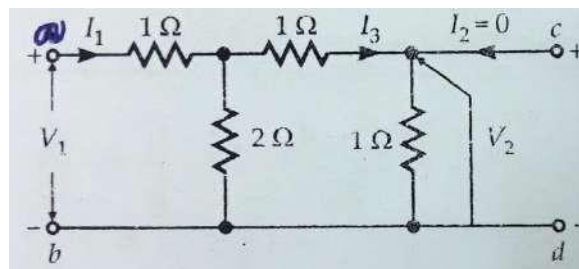
$$C = I_1/V_2 \text{ with } I_2 = 0$$

$$B = V_1/-I_2 \text{ with } V_2 = 0$$

$$D = I_1/-I_2 \text{ with } V_2 = 0$$

**1). We will then find out A and C which are given by the common condition  $I_2 = 0$  (Output open circuited)**

The resulting circuit in this condition is redrawn below.



Applying KVL we can write down the two mesh equations and get the values of A and C :

$$V_1 = I_1 \times 1 + (I_1 - I_3)2$$

or  $V_1 = 3I_1 - 2I_3$  ..(i)

and  $0 = (I_3 - I_1)2 + I_3(1+1) = 4I_3 - 2I_1$

$$\therefore I_3 = \frac{1}{2} I_1$$
 ..(ii)

Utilising (ii) in (i),

$$V_1 = 3I_1 - 2 \times \frac{1}{2} I_1 = 2I_1$$
 ..(iii)

$\therefore$  Again,

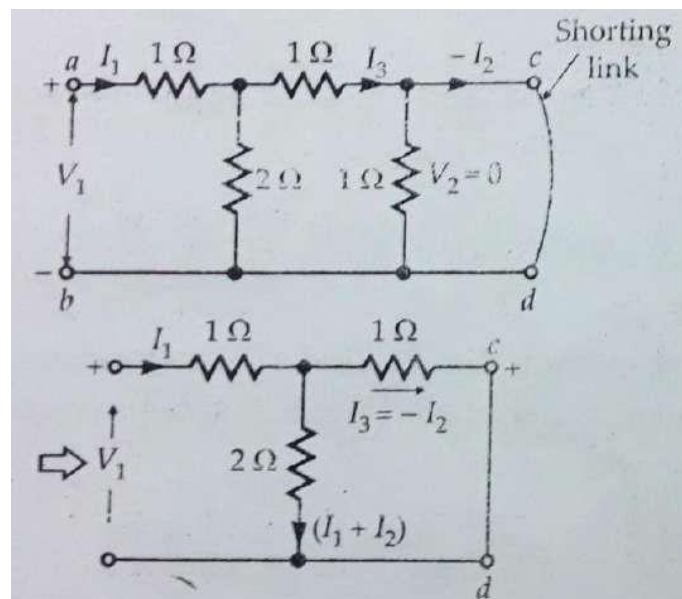
$$V_2 = I_3 \times 1 = \frac{1}{2} I_1$$
 ..(iv)
$$\therefore \left. \frac{I_1}{V_2} \right|_{I_2=0} = 2 \text{ mho} = C.$$

Dividing equation (iii) by (iv),

$$\left. \frac{V_1}{V_2} \right|_{I_2=0} = 4 = A$$

2.) Next we will find out B and D which are given by the common condition  $V_2 = 0$  (Output short circuited)

The resulting simplified network in this condition is redrawn below.



The voltage at the input port is given by :  $V_1 = I_1 x1 + (I_1 + I_2) x2$   
i.e.  $V_1 = 3I_1 + 2I_2$ ..... (i)

And the mesh equation for the closed mesh through 'cd' is given by :

$$0 = I_2 x1 + (I_1 + I_2) x2 \text{ or } 3 I_2 + 2 I_1 = 0 \text{ or } I_1 = -(3/2) \cdot I_2 \text{.....(ii)}$$

Using equation (ii) in the equation (i) above we get :

$$V_1 = -(9/2) I_2 + 2I_2 = -(5/2)I_2$$

$$\text{Or } V_1 / -I_2 = B = (5/2)$$

And from equation (ii) above we can directly get

$$I_1 / -I_2 = D = 3/2$$

Hence the transmission parameters can be written in matrix notation as :

Here we can see that  $AD - BC = 1$  and  $A \neq D$

***Hence the network is Symmetrical but not Reciprocal.***