

# BASIC MECHANICAL ENGINEERING

SECOND EDITION

 Pearson

Pravin Kumar

# *About Pearson*

---

*Pearson is the world's learning company, with presence across 70 countries worldwide. Our unique insights and world-class expertise comes from a long history of working closely with renowned teachers, authors and thought leaders, as a result of which, we have emerged as the preferred choice for millions of teachers and learners across the world.*

*We believe learning opens up opportunities, creates fulfilling careers and hence better lives. We hence collaborate with the best of minds to deliver you class-leading products, spread across the Higher Education and K12 spectrum.*

*Superior learning experience and improved outcomes are at the heart of everything we do. This product is the result of one such effort.*

*Your feedback plays a critical role in the evolution of our products and you can contact us – [reachus@pearson.com](mailto:reachus@pearson.com). We look forward to it.*

*This page is intentionally left blank.*

# Basic Mechanical Engineering

**Second Edition**

**Pravin Kumar**

Assistant Professor  
Department of Mechanical Engineering  
Delhi Technological University (DTU)



*Dedicated to*  
*My Wife and Sons*

**Copyright © 2018 Pearson India Education Services Pvt. Ltd**

Copyright © 2013 Dorling Kindersley (India) Pvt. Ltd

Published by Pearson India Education Services Pvt. Ltd, CIN: U72200TN2005PTC057128.

No part of this eBook may be used or reproduced in any manner whatsoever without the publisher's prior written consent.

This eBook may or may not include all assets that were part of the print version. The publisher reserves the right to remove any material in this eBook at any time.

ISBN 9789386873293

eISBN 9789353063399

Head Office: 15th Floor, Tower-B, World Trade Tower, Plot No. 1, Block-C, Sector-16, Noida 201 301, Uttar Pradesh, India.

Registered Office: 4th Floor, Software Block, Elnet Software City, TS-140,

Block 2 & 9, Rajiv Gandhi Salai, Taramani, Chennai 600 113, Tamil Nadu, India.

Fax: 080-30461003, Phone: 080-30461060

Website: [in.pearson.com](http://in.pearson.com), Email: [companysecretary.india@pearson.com](mailto:companysecretary.india@pearson.com)

# Brief Contents

---

<i>Preface to the Second Edition</i>	xxvii
<i>Preface to the First Edition</i>	xxx
<i>About the Author</i>	xxxii
<i>Acknowledgements</i>	xxxiii
1. Concepts of Thermodynamics and Properties of Gases	1
2. Fuels and Combustion	55
3. Power Plant Engineering and Sources of Energy	73
4. Properties of Steam and Steam Generators	97
5. Steam and Gas Turbines	141
6. Internal Combustion Engines	182
7. Heat Transfer	225
8. Refrigeration and Air Conditioning	239
9. Fluid Mechanics and Hydraulic Machines	273
10. Air Compressors	330
11. Centroid and Moment of Inertia	352
12. Stress and Strain	377
13. Machine Elements	406
14. Flywheel and Governors	431
15. Power Transmission Devices	455
16. Couplings, Clutches, and Brakes	485
17. Engineering Materials	511
18. Mechanical Measurement	529
19. Machine Tools	556
20. Casting and Welding	597
21. Mechanical Working of Metals, Sheet Metal Work, Powder Metallurgy, and Smithy	655
22. Manufacturing Systems: NC, CNC, DNC, and Robotics	695
23. Heat Treatment	716
<i>Appendix 1: Mollier Diagram for Steam</i>	727
<i>Appendix 2: Steam Table</i>	728
<i>Index</i>	739

*This page is intentionally left blank.*

# Contents

---

<i>Preface to the Second Edition</i>	xxvii
<i>Preface to the First Edition</i>	xxx
<i>About the Author</i>	xxxix
<i>Acknowledgements</i>	xxxix

<b>I CONCEPTS OF THERMODYNAMICS AND PROPERTIES OF GASES</b>	<b>1</b>
<b>1.1 Introduction</b>	<b>1</b>
<b>1.2 Important Terminologies Used in Thermodynamics</b>	<b>2</b>
<b>1.3 Specific Heat Capacity</b>	<b>8</b>
1.3.1 Specific Heat at Constant Volume ( $C_v$ )	8
1.3.2 Specific Heat at Constant Pressure ( $C_p$ )	8
1.3.3 Relationship Between $C_p$ and $C_v$	9
<b>1.4 The First Law of Thermodynamics</b>	<b>10</b>
1.4.1 Mechanical Equivalent of Heat	10
1.4.2 Internal Energy	11
1.4.3 Physical Interpretation of Internal Energy	12
1.4.4 Energy Transfer Across the System Boundary (Heat and Work)	13
1.4.5 Non-flow Processes	14
1.4.6 Application of First Law of Thermodynamics in Steady Flow Process and Variable Flow Process	24
1.4.7 Limitations of First Law of Thermodynamics	28
<b>1.5 The Second Law of Thermodynamics</b>	<b>29</b>
1.5.1 Kelvin–Planck Statement	29
1.5.2 Clausius Statement	29
1.5.3 Equivalence of Kelvin–Planck and Clausius Statement	30
<b>1.6 Reversible and Irreversible Processes</b>	<b>32</b>
<b>1.7 The Carnot Cycle</b>	<b>32</b>
<b>1.8 The Clausius Inequality</b>	<b>34</b>
<b>1.9 Entropy and Entropy Generation</b>	<b>34</b>
1.9.1 Entropy	34
1.9.2 Entropy Generation	35
1.9.3 Entropy Balance	35
1.9.4 Evaluation of Entropy Change	36
<b>1.10 Third Law of Thermodynamics</b>	<b>41</b>
<b>1.11 Gas Laws</b>	<b>41</b>
1.11.1 Boyle’s Law	42



1.11.2 Charles's Law	43
1.11.3 Gay–Lussac's Law	43
1.11.4 The Combined Gas Law	44
1.11.5 Gas Constant	45
<i>Points to Remember</i>	46
<i>Important Formulae</i>	48
<i>Multiple-choice Questions</i>	50
<i>Fill in the Blanks</i>	52
<i>Review Questions</i>	52
<i>Exercise Problems</i>	53

## **2 FUELS AND COMBUSTION**

**55**

<b>2.1 Introduction</b>	<b>55</b>
<b>2.2 Coal</b>	<b>56</b>
2.2.1 Analysis of Coal	57
2.2.2 Advantages of Solid Fuels over the Liquid Fuels	58
<b>2.3 Liquid Fuels</b>	<b>58</b>
2.3.1 Petroleum	58
2.3.2 Kerosene	59
2.3.3 Diesel	59
2.3.4 Gasoline	60
2.3.5 Calorific Value of Liquid Fuels	60
2.3.6 Major Contents of Liquid Fuels	60
2.3.7 Advantages and Disadvantages of Liquid Fuels over Solid Fuels	61
<b>2.4 Gaseous Fuels</b>	<b>62</b>
2.4.1 Liquefied Petroleum Gas (LPG)	62
2.4.2 Compressed Natural Gas (CNG)	62
2.4.3 Advantages and Disadvantages of Gaseous Fuels over the Solid Fuels	63
<b>2.5 Biofuels</b>	<b>63</b>
2.5.1 Bioalcohols	63
2.5.2 Biodiesel	64
2.5.3 Green Diesel	64
2.5.4 Vegetable Oil	65
2.5.5 Biogas	65
2.5.6 Bioethers	65
2.5.7 Syngas	65
2.5.8 Solid Biofuels	65
2.5.9 Scope of Second-generation Biofuels	66
<b>2.6 Combustion</b>	<b>66</b>
2.6.1 Principle of Combustion	66
<b>2.7 Determination of Calorific Value of Fuel Using Bomb Calorimeter</b>	<b>67</b>
<i>Points to Remember</i>	69
<i>Important Formulae</i>	70
<i>Review Questions</i>	72
<i>Exercise Problems</i>	72

---

## 3 POWER PLANT ENGINEERING AND SOURCES OF ENERGY 73

- 3.1 Introduction 73
- 3.2 Prime Movers 73
  - 3.2.1 Historical Development of Prime Movers 74
- 3.3 Power Plant Engineering 74
  - 3.3.1 Thermal Power Plant 75
  - 3.3.2 Hydroelectric Power Plant 76
  - 3.3.3 Nuclear Power Plant 76
  - 3.3.4 Diesel Power Plant 80
  - 3.3.5 Tidal Power Plant 82
  - 3.3.6 The Geothermal Power Plant 85
  - 3.3.7 Windmill 87
- 3.4 Sources of Energy 89
  - 3.4.1 Renewable Energy 89
  - 3.4.2 Non-renewable Energy 91

*Points to Remember* 93

*Multiple Choice Questions* 94

*Answers* 95

*Review Questions* 95

## 4 PROPERTIES OF STEAM AND STEAM GENERATORS 97

- 4.1 Introduction 97
- 4.2 Formation of Steam at Constant Pressure 97
- 4.3 Throttling Calorimeter 108
- 4.4 Separating and Throttling Calorimeter 110
- 4.5 Steam Table 111
- 4.6 Mollier Diagram or  $h$ - $S$  Chart 111
- 4.7 Steam Generators/Boilers 112
  - 4.7.1 Classification of Boilers 112
  - 4.7.2 Requirements of a Good Boiler 113
  - 4.7.3 Cochran Boiler 114
  - 4.7.4 Babcock and Wilcox Boiler 115
  - 4.7.5 Locomotive Boiler 116
  - 4.7.6 Lancashire Boiler 117
  - 4.7.7 Cornish Boiler 118
- 4.8 Boiler Mountings 118
  - 4.8.1 Safety Valves 118
  - 4.8.2 High Steam Low Water Safety Valve 120
  - 4.8.3 Water Level Indicator 121
  - 4.8.4 Pressure Gauge 122
  - 4.8.5 Feed Check Valve 122

- 4.8.6 Steam Stop Valve 123
- 4.8.7 Blow-off Cock 123
- 4.8.8 Fusible Plug 124
- 4.8.9 Manhole 125

**4.9 Boiler Accessories 125**

- 4.9.1 Economizer 125
- 4.9.2 Air Preheater 126
- 4.9.3 Superheater 127
- 4.9.4 Feed Pump 127
- 4.9.5 Injector 128
- 4.9.6 Steam Trap 128
- 4.9.7 Steam Separator 128
- 4.9.8 Pressure Reducing Valve 129

**4.10 Performance of Boilers 129**

- Points to Remember* 133
- Important Formulae* 135
- Multiple-choice Questions* 135
- Fill in the Blanks* 137
- Review Questions* 138
- Exercise Problems* 138

**5 STEAM AND GAS TURBINES**

**141**

**5.1 Introduction 141**

**5.2 Steam Engines and their Working Principles 141**

- 5.2.1 Modified Rankine Cycle: Theoretical Indicator Diagram 143
- 5.2.2 Rankine Cycle 145

**5.3 Steam Turbines 147**

- 5.3.1 Classification of Steam Turbine 147
- 5.3.2 Compounding of Impulse Turbine 153
- 5.3.3 Impulses-reaction Turbine (Reaction Turbine) 157
- 5.3.4 Differences Between Impulse and Reaction Turbines 164
- 5.3.5 Losses in Steam Turbines 164
- 5.3.6 Governing of Steam Turbines 164

**5.4 Gas Turbines 165**

- 5.4.1 Classification of Gas Turbine 165
- 5.4.2 Applications of Gas Turbines 165
- 5.4.3 Gas Turbine Cycle with Regenerator 175
- 5.4.4 Gas Turbine Cycle with Reheating and Intercooling 175

- Points to Remember* 176
- Important Formulae* 177

*Objective Questions* 178  
*Fill in the Blanks* 179  
*Review Questions* 180  
*Exercise Problems* 181

## 6 INTERNAL COMBUSTION ENGINES

182

**6.1 Introduction** 182

**6.2 Classification of I.C. Engines** 183

**6.3 Basic Structure of I.C. Engines** 185

6.3.1 Nomenclature 187

**6.4 Working Principle of I.C. Engines** 188

6.4.1 Four-stroke Spark Ignition Engine 188

6.4.2 Four-stroke Compression Ignition Engine 190

6.4.3 Two-stroke Spark Ignition Engine 192

6.4.4 Two-stroke C.I. Engine 194

6.4.5 Comparison Between Four-stroke and Two-stroke Engines 196

6.4.6 Comparison Between S.I. and C.I. Engines 197

6.4.7 Comparison Between Otto Cycle and Diesel Cycle 197

**6.5 Valve Timing Diagrams** 197

6.5.1 Valve Timing Diagram for Four-stroke S.I. Engines 197

6.5.2 Port Timing Diagram for Two-stroke S.I. Engines 198

6.5.3 Valve Timing Diagram for Four-stroke C.I. Engine 199

**6.6 Otto Cycle** 200

**6.7 Diesel Cycle** 203

**6.8 Dual Cycle** 206

**6.9 Engine Performance Parameters** 209

**6.10 Emission Control** 212

6.10.1 Types of Emissions 212

6.10.2 Emission Control Techniques 212

**6.11 Some Recent Developments in Automotive Technology** 214

6.11.1 Multi-point Fuel Injection 214

6.11.2 Common Rail Direct Injection (CRDI) 216

6.11.3 Hybrid Engine 217

*Points to Remember* 218

*Important Formulae* 219

*Multiple-choice Questions* 219

*Fill in the Blanks* 220

*Review Questions* 221

*Exercise Problems* 222

<b>7 HEAT TRANSFER</b>	<b>225</b>
<b>7.1 Introduction</b>	<b>225</b>
7.1.1 Conduction	225
7.1.2 Convection	227
7.1.3 Radiation	228
7.1.4 Combined Heat Transfer	229
<i>Points to Remember</i>	235
<i>Important Formulae</i>	236
<i>Multiple-choice Questions</i>	237
<i>Review Questions</i>	238
<i>Exercise Problems</i>	238
<b>8 REFRIGERATION AND AIR CONDITIONING</b>	<b>239</b>
<b>8.1 Introduction</b>	<b>239</b>
<b>8.2 Refrigerator and Heat Pump</b>	<b>240</b>
<b>8.3 Components of Refrigeration System</b>	<b>241</b>
8.3.1 Evaporator	241
8.3.2 Compressor	241
8.3.3 Condenser	242
8.3.4 Expansion Valve	242
<b>8.4 Types of Refrigeration Systems</b>	<b>242</b>
8.4.1 Air-refrigeration System	242
8.4.2 Vapour Compression Refrigeration System	247
8.4.3 Absorption Refrigeration Cycle	250
<b>8.5 Type of Refrigerants</b>	<b>250</b>
<b>8.6 Domestic Refrigerator</b>	<b>251</b>
<b>8.7 Psychrometry</b>	<b>253</b>
<b>8.8 Psychrometric Processes</b>	<b>254</b>
8.8.1 Psychrometric Chart	254
<b>8.9 Air Washers</b>	<b>264</b>
<b>8.10 Human Comfort Conditions</b>	<b>264</b>
<b>8.11 Room Air Conditioner</b>	<b>265</b>
8.11.1 Window Air Conditioner	265
8.11.2 Split Air Conditioner	266
8.11.3 Difference Between Split and Window ACs	267
<i>Points to Remember</i>	268
<i>Important Formulae</i>	268
<i>Multiple-choice Questions</i>	269
<i>Review Questions</i>	271
<i>Exercise Problems</i>	272

---

**9 FLUID MECHANICS AND HYDRAULIC MACHINES 273****FLUID MECHANICS 273****9.1 Introduction 273****9.2 Properties of Fluids 273**

9.2.1 Density 274

9.2.2 Viscosity 274

9.2.3 Newtonian and Non-Newtonian Fluids 276

9.2.4 Surface Tension 277

9.2.5 Capillarity 278

9.2.6 Pressure Variation with Depth 280

**9.3 Bernoulli's Equation 281****9.4 Types of Flow 284****HYDRAULIC MACHINES 284****9.5 Introduction 284****9.6 Hydraulic Turbines 285**

9.6.1 Classification of Hydraulic Turbines 285

**9.7 Terminology Used in Turbine 286****9.8 Pelton Turbine 287**

9.8.1 Main Components of Pelton Turbine 287

9.8.2 Selection of Speed of Pelton Turbine 288

9.8.3 Velocity Triangle for Pelton Turbine 289

**9.9 Francis Turbine 293**

9.9.1 Main Components of Francis Turbine 293

9.9.2 Different Shapes of Draft Tubes 295

**9.10 Kaplan Turbine 299**

9.10.1 Velocity Triangle for Kaplan Turbine 300

**9.11 Governing of Turbines 304****9.12 Pumps 304****9.13 Centrifugal Pump 304**

9.13.1 Main Components of Centrifugal Pump 304

9.13.2 Velocity Triangle for Centrifugal Pump 306

9.13.3 Various Heads and Efficiencies of  
Centrifugal Pumps 3079.13.4 Some Important Points Related to  
Centrifugal Pump 307**9.14 Reciprocating Pump 311**

9.14.1 Air Vessels 315

**9.15 Gear Pump 317**

- 9.16 Vane Pump 318
- 9.17 Lobe Pump 318
- 9.18 Screw Pump 319
  - 9.18.1 Two-screw, Low-pitch, Screw Pump 319
  - 9.18.2 Three-screw, High-pitch, Screw Pump 319
  - Points to Remember* 321
  - Important Formulae* 322
  - Multiple-choice Questions* 325
  - Review Questions* 327
  - Exercise Problems* 328

## 10 AIR COMPRESSORS

330

- 10.1 Introduction 330
- 10.2 Classification of Compressors 330
- 10.3 Reciprocating Compressors 331
  - 10.3.1 Polytropic Compression 333
  - 10.3.2 Isothermal Compression 334
  - 10.3.3 Effect of Clearance on Work Done 334
  - 10.3.4 Volumetric Efficiency 335
  - 10.3.5 Multistage Compression 337
  - 10.3.6 Work Done in Multistage Compression 337
- 10.4 Rotary compressors 342
  - 10.4.1 Fixed Vane Type Compressors 342
  - 10.4.2 Multiple Vane Type Rotary Compressors 343
- 10.5 Centrifugal Compressors 344
- 10.6 Axial Flow Compressors 345
  - Points to Remember* 346
  - Important Formulae* 347
  - Multiple-choice Questions* 348
  - Fill in the Blanks* 350
  - Review Questions* 350
  - Exercise Problems* 351

## 11 CENTROID AND MOMENT OF INERTIA

352

- 11.1 Introduction 352
- 11.2 Determination of Position of Centroid of Plane Geometric Figures 352
  - 11.2.1 Center of Gravity, Center of Mass, and Centroid of an Irregular Shape 352
  - 11.2.2 Centroid of I-section 354

11.2.3	Centroid of U-section	354
11.2.4	Centroid of H-section	355
11.2.5	Centroid of L-section	355
11.2.6	Centroid of T-section	356
11.2.7	Centroid of C-section	356
11.2.8	Centroid of Circular Arc	357
11.2.9	Centroid of Semicircular-section of a Disc	357
11.2.10	Centroid of a Sector of a Circular Disc	358
11.2.11	Centroid of a Parabola	358
11.2.12	Centroid of a Triangle	359
<b>11.3</b>	<b>Second Moment of Area</b>	<b>360</b>
11.3.1	Radius of Gyration	360
11.3.2	Theorem of Perpendicular Axis	361
11.3.3	Theorem of Parallel Axis	361
11.3.4	Moment of Inertia from First Principle	361
11.3.5	Moment of Inertia of Some Composite Sections	363
<b>11.4</b>	<b>Center of Gravity of Solids</b>	<b>363</b>
<b>11.5</b>	<b>Mass Moment of Inertia</b>	<b>363</b>
11.5.1	Mass Moment of Inertia of a Circular Ring	363
11.5.2	Mass Moment of Inertia of a Circular Disc	364
11.5.3	Mass Moment of Inertia of a Hollow Cylinder	365
11.5.4	Mass Moment of Inertia of Sphere	365
11.5.5	Mass Moment of Inertia of a Circular Cone	366
	<i>Points to Remember</i>	368
	<i>List of Mass Moment of Inertia</i>	368
	<i>List of Area Moment of Inertia</i>	371
	<i>Important Formulae</i>	373
	<i>Multiple-choice Questions</i>	374
	<i>Review Questions</i>	375
	<i>Exercise Problems</i>	376

## 12 STRESS AND STRAIN

377

12.1	Introduction	377
12.2	Hooke's Law	379
12.3	Stress–Strain Diagram	379
12.4	Extension in Varying Cross-section or Taper Rod	383
12.5	Stress and Strain in Varying Cross-section Bar of Uniform Strength	385
12.6	Stress and Strain in Compound Bar	386
12.7	Stress and Strain in an Assembly of Tube and Bolt	387
12.8	Stress and Strain in Composite Bar	392
12.9	Temperature Stress	393



12.10 Stress and Strain Due to Suddenly Applied Load 394  
12.11 Stress and Strain for Impact Load 395  
12.12 Relation Between Stress and Volumetric Strain 396  
12.13 Relation Between Modulus of Elasticity and Bulk Modulus 397  
12.14 Relation Between Modulus of Elasticity and Modulus of Rigidity 397  
    Points to Remember 401  
    Important Formulae 402  
    Multiple-choice Questions 403  
    Review Questions 404  
    Exercise Problems 405

### 13 MACHINE ELEMENTS

406

#### SPRINGS 406

13.1 Introduction 406  
13.2 Types of Springs 407  
13.3 Materials used for Springs 409  
13.4 Shear Stress in Helical Springs 410  
13.5 Deflection in Helical Spring 412  
13.6 Series and Parallel Connection of Helical Springs 414

#### CAM AND FOLLOWER 416

13.7 Introduction 416  
13.8 Types of Cams 417  
13.9 Types of Followers 418

#### BUSHING AND ROLLER BEARING 420

13.10 Introduction 420  
13.11 Bushing Materials 420  
13.12 Bearings 421  
    13.12.1 Sliding Contact or Bush Bearings 421  
    13.12.2 Rolling Contact Bearings 422  
13.13 Properties of Bearing Materials 426  
13.14 Bearing Materials 427  
    Points to Remember 427  
    Important Formulae 427  
    Multiple-choice Questions 428  
    Review Questions 430  
    Exercise Problems 430

---

## 14 FLYWHEEL AND GOVERNORS 431

### FLYWHEEL 431

#### 14.1 Introduction 431

#### 14.2 Mass Moment of Inertia of Flywheel 432

### GOVERNORS 434

#### 14.3 Introduction 434

#### 14.4 Terminology Used in Governors 435

#### 14.5 Classification of Governors 436

#### 14.6 Gravity Controlled Centrifugal Governors 436

##### 14.6.1 Watt Governor 436

##### 14.6.2 Porter Governor 437

##### 14.6.3 Proell Governor 440

#### 14.7 Spring Controlled Centrifugal Governor 442

##### 14.7.1 Hartnell Governor 442

##### 14.7.2 Willson–Hartnell Governor 445

##### 14.7.3 Hartung Governor 447

#### 14.8 Sensitiveness of Governors 448

#### 14.9 Governing of I.C. Engines 449

##### 14.9.1 Qualitative Governing 449

##### 14.9.2 Quantitative Governing 449

##### 14.9.3 Hit and Miss Governing 449

#### 14.10 Differences Between Flywheel and Governors 450

*Points to Remember* 450

*Important Formulae* 451

*Multiple-choice Questions* 452

*Review Questions* 453

*Exercise Problems* 454

## 15 POWER TRANSMISSION DEVICES 455

### 15.1 Introduction 455

### 15.2 Belt Drive 455

#### 15.2.1 Type of Belt Cross-sections 456

#### 15.2.2 Velocity Ratio 457

#### 15.2.3 Creep 458

#### 15.2.4 Flat Belt Drives 458

#### 15.2.5 Ratio of Tensions 463

#### 15.2.6 Effect of Centrifugal Force on Belt Drive 465

### 15.3 Rope Drive 468

- 15.4 Chain Drive 469
  - 15.4.1 Chain Length 469
  - 15.4.2 Types of Chain 471
- 15.5 Gear Drive 472
  - 15.5.1 Gear Terminology 472
  - 15.5.2 Law of Gearing 474
  - 15.5.3 Forms of Teeth 475
- 15.6 Classification of Gears 476
  - 15.6.1 Parallel Shafts 476
  - 15.6.2 Intersecting Shaft 477
  - Points to Remember* 479
  - Important Formulae* 480
  - Multiple-choice Questions* 481
  - Fill in the Blanks* 482
  - Review Questions* 483
  - Exercise Problems* 483

**16 COUPLINGS, CLUTCHES, AND BRAKES**

**485**

**COUPLINGS 485**

- 16.1 Introduction 485
- 16.2 Rigid Coupling 485
- 16.3 Flexible Bushed Coupling 486
- 16.4 Universal Joint 487

**CLUTCHES 488**

- 16.5 Introduction 488
- 16.6 Single Plate Clutch 488
- 16.7 Multi-plate Disc Clutch 493
- 16.8 Cone Clutch 494
- 16.9 Centrifugal Clutch 496

**BRAKES 497**

**16.10 Introduction 497**

- 16.10.1 Block or Shoe Brake 497
- 16.10.2 Band Brake 500
- 16.10.3 Band and Block Brake 503
- 16.10.4 Internal Expanding Shoe Brake 504
- Points to Remember* 507
- Important Formulae* 507
- Multiple-choice Questions* 508
- Review Questions* 509
- Exercise Problems* 510

---

<b>17 ENGINEERING MATERIALS</b>	<b>511</b>
<b>17.1 Introduction</b>	<b>511</b>
<b>17.2 Mechanical Properties of Engineering Materials</b>	<b>512</b>
<b>17.3 Mechanical Testing of Engineering Materials</b>	<b>513</b>
17.3.1 Tensile Test	513
17.3.2 Hardness	515
<b>17.4 Impact Test</b>	<b>518</b>
<b>17.5 Classification of Engineering Materials</b>	<b>519</b>
17.5.1 Ferrous Metals	519
17.5.2 Non-ferrous Metals	522
17.5.3 Plastics	523
17.5.4 Abrasive Materials	524
17.5.5 Ceramics	524
17.5.6 Silica	525
17.5.7 Glasses	525
<i>Points to Remember</i>	525
<i>Multiple-choice Questions</i>	526
<i>Review Questions</i>	528
<b>18 MECHANICAL MEASUREMENT</b>	<b>529</b>
<b>18.1 Introduction</b>	<b>529</b>
<b>18.2 Temperature Measurement</b>	<b>530</b>
18.2.1 Thermocouple	530
18.2.2 Resistance Temperature Devices (RTD)	530
18.2.3 Infrared Temperature Measurement Devices	530
18.2.4 Bimetallic Temperature Measurement Devices	530
18.2.5 Fluid-expansion Temperature Measurement Devices	531
18.2.6 Change-of-state Temperature Measurement Devices	531
<b>18.3 Pressure Measurement</b>	<b>531</b>
18.3.1 Manometers	532
18.3.2 Bourdon Tube Pressure Gauge	533
18.3.3 Low Pressure Measurement	534
<b>18.4 Velocity Measurement</b>	<b>535</b>
18.4.1 Velocity Measurement of Fluid with Pitot Tube	535
18.4.2 Hot Wire Anemometer	536
<b>18.5 Flow Measurement</b>	<b>536</b>
18.5.1 Flow Measurement Through Velocity of Fluid Over Known Area	536
18.5.2 Orificemeter	538
18.5.3 Rotameter	538

<b>18.6 Strain Measurement</b>	<b>539</b>
18.6.1 Strain Gauge	540
<b>18.7 Force Measurement</b>	<b>541</b>
18.7.1 Cantilever Beam	542
<b>18.8 Torque Measurement</b>	<b>543</b>
18.8.1 Prony Brake Dynamometer	543
18.8.2 Rope Brake Dynamometer	543
18.8.3 Torque Measurement by Pointer and Scale	544
<b>18.9 Measurement Errors</b>	<b>545</b>
<b>18.10 Uncertainties of Measurement</b>	<b>546</b>
<b>18.11 Vernier calipers</b>	<b>546</b>
<b>18.12 Micrometer or Screw Gauge</b>	<b>547</b>
18.12.1 Measurement Procedure	549
<b>18.13 Dial Gauge or Dial Indicator</b>	<b>549</b>
<b>18.14 Slip Gauges</b>	<b>549</b>
18.14.1 Classification of Slip Gauges	550
18.14.2 Applications of Slip Gauge	551
<b>18.15 Sine Bar</b>	<b>551</b>
<b>18.16 Combination Set</b>	<b>552</b>
<i>Points to Remember</i>	553
<i>Multiple-choice Questions</i>	554
<i>Review Questions</i>	555

## **19 METAL CUTTING AND MACHINE TOOLS**

**556**

<b>19.1 Introduction</b>	<b>556</b>
<b>19.2 Mechanism of Metal Cutting</b>	<b>557</b>
19.2.1 Types of Chip Formation	557
<b>19.3 Orthogonal and Oblique Metal Cutting</b>	<b>558</b>
<b>19.4 Lathe</b>	<b>559</b>
19.4.1 Classification of Lathes	559
19.4.2 Specifications of Lathe	560
19.4.3 Constructional Detail of Lathe	560
19.4.4 Power Transmission System in Lathe Machine	562
19.4.5 Cutting Tools Used in Lathe	564
19.4.6 Types of Operations on Lathe Machine	564
<b>19.5 Shaper, Slotter, and Planer</b>	<b>569</b>
19.5.1 Shaping and Planing	569
19.5.2 Constructional Detail of Shaper	570
19.5.3 Slotter Machine	571

19.5.4	Crank and Slotted Arm Quick Return Mechanism	571
19.5.5	Specification of Shaper	572
19.5.6	Constructional Detail of Planer	573
19.5.7	Fast and Loose Pulleys Driving Mechanism of Planer	573
19.5.8	Specifications of Planer	575
19.5.9	Difference Between Shaper and Planer	575
<b>19.6</b>	<b>Drilling Machine</b>	<b>575</b>
19.6.1	Driving Mechanism in Drilling Machine	575
19.6.2	Drill Bit	576
19.6.3	Specifications of a Drilling Machine	577
19.6.4	Operations Performed on Drilling Machine	577
19.6.5	Advanced Types of Drilling Machine	579
<b>19.7</b>	<b>Boring</b>	<b>580</b>
19.7.1	Specification of Boring Machines	580
<b>19.8</b>	<b>Milling Machines</b>	<b>581</b>
19.8.1	Constructional Detail of Milling Machine	581
19.8.2	Basic Milling Operations	582
19.8.3	Nomenclature of Milling Cutter	585
<b>19.9</b>	<b>Grinding Machines</b>	<b>586</b>
19.9.1	Grinding Wheel Specification	586
19.9.2	Methods of Grindings	588
19.9.3	Cylindrical Grinders	589
19.9.4	Plain Cylindrical Grinders	590
19.9.5	Plain Surface Grinders	590
19.9.6	Universal Cylindrical Grinders	591
19.9.7	Centerless Grinders	591
	<i>Points to Remember</i>	593
	<i>Multiple-choice Questions</i>	594
	<i>Fill in the Blanks</i>	595
	<i>Review Questions</i>	596

## 20 CASTING AND WELDING

597

### CASTING 597

<b>20.1</b>	<b>Introduction</b>	<b>597</b>
<b>20.2</b>	<b>Classification of Casting Process</b>	<b>598</b>
<b>20.3</b>	<b>Sand Casting</b>	<b>598</b>
20.3.1	Steps in Sand Casting	599
20.3.2	Pattern Making	600
20.3.3	Types of Pattern	601
20.3.4	Mould Making	605
20.3.5	Properties of Mouldings Sands	607
20.3.6	Hand Tools Used in Moulding	608

20.3.7	Moulding Procedure	609
20.3.8	Gating System	610
20.3.9	Chills	611
20.3.10	Chaplets	612
20.3.11	Cores	612
20.3.12	Sand Testing	614
<b>20.4</b>	<b>Special Casting Methods</b>	<b>615</b>
20.4.1	Gravity/Permanent Mould Casting	615
20.4.2	Die Casting	615
20.4.3	Centrifugal Casting	617
<b>20.5</b>	<b>Casting Defects</b>	<b>619</b>
<b>20.6</b>	<b>Surface Cleaning of the Casting</b>	<b>621</b>
	<b>WELDING</b>	<b>622</b>
<b>20.7</b>	<b>Introduction</b>	<b>622</b>
20.7.1	Definition of Welding	622
<b>20.8</b>	<b>Classification of Welding Process</b>	<b>624</b>
<b>20.9</b>	<b>Gas Welding</b>	<b>625</b>
20.9.1	Oxyacetylene Welding	625
20.9.2	Gas Welding Methods	628
<b>20.10</b>	<b>Electric Arc Welding</b>	<b>629</b>
20.10.1	Functions of Electrode Coatings	631
20.10.2	Ingredients of Electrode Coating	632
20.10.3	Selection of Electrodes	632
20.10.4	Specifications for Electrodes	632
<b>20.11</b>	<b>Types of Electric Arc Welding</b>	<b>633</b>
20.11.1	Carbon Arc Welding	633
20.11.2	Shielded Metal Arc Welding (SMAW)	633
20.11.3	Metal Inert Gas Arc Welding (MIG)/Gas Metal Arc Welding (GMAW)	634
20.11.4	Tungsten Inert Gas Arc Welding (TIG)/Gas Tungsten Arc Welding (GTAW)	635
20.11.5	Submerged Arc Welding (SAW)	636
20.11.6	Electroslag Welding	637
20.11.7	Atomic Hydrogen Welding	638
20.11.8	Plasma Arc Welding	639
<b>20.12</b>	<b>Resistance Welding</b>	<b>640</b>
20.12.1	Resistance Spot Welding	641
20.12.2	Resistance Seam Welding	642
20.12.3	Resistance Projection Welding	642
20.12.4	Flash Welding	643

- 20.12.5 Percussion Welding 644
- 20.12.6 Resistance Butt Welding 645
- 20.13 Thermit Welding 645**
- 20.14 Welding Allied Processes 645**
  - 20.14.1 Soldering 645
  - 20.14.2 Brazing 646
  - 20.14.3 Braze Welding 647
- 20.15 Welding Defects 648**
  - Points to Remember* 649
  - Multiple-choice Questions* 650
  - Fill in the Blanks* 653
  - Review Questions* 654

## **21 MECHANICAL WORKING OF METALS, SHEET METAL WORK, POWDER METALLURGY, AND SMITHY 655**

### **MECHANICAL WORKING PROCESS 655**

- 21.1 Introduction 655**
  - 21.1.1 Advantages of Mechanical Working Process Over Other Manufacturing Processes 656
- 21.2 Rolling 657**
  - 21.2.1 Terminology 657
  - 21.2.2 Types of Rolling Mills 658
  - 21.2.3 Rolling Defects 659
- 21.3 Forging 660**
  - 21.3.1 Different Types of Forging 660
- 21.4 Extrusion 663**
  - 21.4.1 Hot Extrusion 664
  - 21.4.2 Cold Extrusion 664
  - 21.4.3 Impact Extrusion 664
- 21.5 Wire Drawing 665**
- 21.6 Bar Drawing 666**
- 21.7 Tube Drawing 666**
- 21.8 High Energy Rate Forming 667**
  - 21.8.1 Explosive Forming 667
  - 21.8.2 Electrohydraulic Forming 668
  - 21.8.3 Electromagnetic Forming 668
- 21.9 Thread Rolling 668**
- 21.10 Piercing or Seamless Tubing 669**
- 21.11 Some Other Forming Processes 670**



***SHEET METAL PROCESS 671***

**21.12 Introduction 671**

**21.13 Sheet Metal Joints 671**

**21.14 Materials Used for Sheet Metal 672**

**21.15 Hand Tools Used in Sheet Metal Work 673**

**21.16 Sheet Metal Operations 677**

21.16.1 Shearing 677

21.16.2 Bending 678

21.16.3 Stretch Forming 678

21.16.4 Deep Drawing 678

21.16.5 Hot Spinning 680

***POWDER METALLURGY 681***

**21.17 Introduction 681**

**21.18 Manufacturing of Metal Powders 681**

21.18.1 Characteristics of Metal Powder 681

21.18.2 Methods of Production 681

**21.19 Blending/Mixing of the Metal Powders 682**

**21.20 Compacting 683**

**21.21 Sintering 684**

**21.22 Finishing Operations 684**

**21.23 Advantages of Powder Metallurgy 684**

**21.24 Limitations of Powder Metallurgy 685**

**21.25 Applications of Powder Metallurgy 685**

***SMITHY 685***

**21.26 Introduction 685**

**21.27 Major Tools Used in Smithy Shop 686**

21.27.1 Smith's Forge or Hearth 686

21.27.2 Anvil 686

21.27.3 Hammer 687

21.27.4 Swage Block 688

21.27.5 Tongs 689

21.27.6 Chisels 689

21.27.7 Punches 690

21.27.8 Flatters 690

21.27.9 Set Hammer 690

21.27.10 Fullers 690

21.27.11 Swages 691

*Points to Remember* 691  
*Multiple-choice Questions* 693  
*Fill in the Blanks* 693  
*Review Questions* 694

## **22 MANUFACTURING SYSTEMS: NC, CNC, DNC, AND ROBOTICS 695**

### **22.1 Introduction 695**

22.1.1 Production Machines, Tools, Fixtures, and Other  
 Related Hardware 695  
 22.1.2 Material Handling System 696  
 22.1.3 Computer Systems 696  
 22.1.4 Human Workers 696

### **22.2 Automation 696**

### **22.3 Computer Integrated Manufacturing (CIM) 698**

### **22.4 CAD/CAM 698**

22.4.1 Computer Aided Design (CAD) 698  
 22.4.2 Computer Aided Manufacturing (CAM) 699

### **22.5 Numerical Control (NC) 700**

22.5.1 Limitations/Drawback of Conventional  
 NC System 700

### **22.6 Computer Numerical Control (CNC) 701**

### **22.7 Programming Methods 701**

### **22.8 Comparison of NC and CNC Machines 703**

### **22.9 Direct Numerical Control (DNC) 703**

### **ROBOTICS 704**

### **22.10 Introduction 704**

### **22.11 Robot Anatomy 705**

### **22.12 Three Degree of Freedom for Robot's Wrist 706**

### **22.13 Robot Configurations 706**

### **22.14 Robot Control 708**

22.14.1 Type of Robot Control 708

### **22.15 Control Systems 709**

22.15.1 Basic Form of Control Systems 709  
 22.15.2 Sequential Control 711  
 22.15.3 Microprocessor Based Controllers 711  
 22.15.4 Sensors Used in Robotics 711  
 22.15.5 Transducers used in Robotics 712

**22.16 Applications of Robots 712**

- Points to Remember* 713
- Multiple-choice Questions* 714
- Review Questions* 715

**23 HEAT TREATMENT**

**716**

- 23.1 Introduction 716**
- 23.2 Iron–Carbon Phase Diagram 716**
- 23.3 TTT (Time–Temperature–Transformation) Diagram 718**
- 23.4 Normalizing 719**
- 23.5 Annealing 720**
- 23.6 Spheroidizing 720**
- 23.7 Hardening 720**
- 23.8 Tempering 721**
  - 23.8.1 Austempering 721
  - 23.8.2 Martempering 721
- 23.9 Carburizing 722**
- 23.10 Cyaniding 723**
- 23.11 Nitriding 723**
- 23.12 Induction Hardening 723**
  - Points to Remember* 724
  - Multiple-choice Questions* 725
  - Fill in the Blanks* 725
  - Review Questions* 726

<i>Appendix 1: Mollier Diagram for Steam</i>	727
<i>Appendix 2: Steam Table</i>	728
<i>Index</i>	739

# Preface to the Second Edition

---

It is my great pleasure to present the second edition of the Basic Mechanical Engineering textbook after the much praised first edition of the book. Due to continuous change in the curriculum of the engineering education, it becomes necessary to modify the contents of the book as per the requirements of the universities. After the first edition, it has been observed that few topics of the book are not much relevant for the first year engineering students, for example, Chapter 13—Lifting Machines and Chapter 23—Unconventional Machining Processes and therefore, these two chapters are removed from the second edition of the book.

Also, in the second edition, several topics have been added. Global warming and bio-fuels are now discussed in detail in Chapter 2. Due to fast change in the technology, some advanced technologies such as Multi-point Fuel Injection Engine (MPFI), Common Rail Direct Injection (CRDI), Hybrid Engines have been introduced in Chapter 6. Chapter 13 has been upgraded by removing the Lifting Machines and adding spring, CAM and followers, and bushing and bearing. In Chapter 19, grinding and surface finishing processes have been included. Smithy works have been added in Chapter 21. Introduction to Automation and Robotics have been included in Chapter 22.

In addition to the above changes, some minor improvements have been done in the entire book and the questions asked in various university examinations have also been included. These questions are indicated by an asterisk (\*) symbol.

## Chapter Structure and Coverage

This book provides a basic knowledge of the various aspects of mechanical engineering. The chapter structure and coverage are discussed below:

**Chapter 1** covers the laws of thermodynamics and properties of gases. Under the laws of thermodynamics, we first discuss, second and third laws of thermodynamics, concepts of specific heat, enthalpy, entropy, etc., followed by the discussion on properties of gases such as Boyle's Law, Charles's Law, Gay Lussac's Law, combined gas law and gas constant, etc.

**Chapter 2** deals with fuels and their combustion. The various types of fuels such as solid, liquid, and gaseous fuels are introduced and their applications for power generation have been discussed. Again to measure the calorific value of fuel, a basic idea about calorimeters and their working procedure has been given.

**Chapter 3** describes power plant engineering. In this chapter, the methods of conversion of various forms of energy into mechanical energy and electrical energy along with an introduction to the basic concepts of thermal power plant, hydroelectric power plant, and nuclear power plant with some of the non-conventional energy sources has been discussed.

**Chapter 4** covers steam properties and its generation. Various properties of steam such as internal energy, enthalpy, and entropy at different ambient conditions are discussed. The steam table and the Mollier diagram that are helpful in showing the methods to find the properties of steam at the given condition are also introduced. In addition to this, the working of steam generators (boilers) and the functions of various mountings and accessories used in boilers are also discussed.

**Chapter 5** deals with the conversion of heat energy into mechanical energy or shaft power followed by discussion on the working of steam engines, steam turbines, and gas turbines in detail. These are the devices used to convert heat energy carried by steam or gases into shaft power. The shaft power is further converted into electrical energy using an electricity generator.

**Chapter 6** describes internal combustion engines and their working. There is a wide scope to discuss various mechanisms and developments in I.C. engines, we have however focused our discussion only to the basic concepts of working on I.C. engines such as petrol (Gasoline) engines, diesel engines, two-stroke engines, four-stroke engines, thermodynamic cycles, and performance measurement of an I.C. engine.

**Chapter 7** deals with the various modes of heat transfer. It gives a basic idea about the thermal conductivity and the overall heat transfer coefficient.

**Chapter 8** covers refrigeration and air conditioning. Refrigeration deals with the various types of processes such as vapor compression refrigeration, air refrigeration, absorption type refrigeration, and the properties of some of the refrigerants. Air conditioning deals with psychrometric properties of air and the processes to control these properties.

**Chapter 9** covers fluid mechanics and hydraulic machines. Fluid mechanics provides an introduction to fluid statics and fluid dynamics. Hydraulic machines deal with the working of water turbines, water pumps, hydraulic coupling, and torque converters.

**Chapter 10** describes air compression systems. Single-stage and multistage compressors, as well as rotary compressors, are discussed in detail and vane type compressors, centrifugal compressors, and axial flow compressors are discussed at an introductory level.

**Chapter 11** describes centroid, the center of gravity and moment of inertia for various sections. Parallel and perpendicular axis theorems are used to find the moment of inertia for the different cross sections. This chapter is very useful to analyze the dynamics of a machine element.

**Chapter 12** describes stress and strain, that is, the properties of materials under various types of loading. It also demonstrates relationships among different types of elastic constants.

**Chapter 13** deals with springs, different types of CAMs and followers, bushing and bearing.

**Chapter 14** describes the working of flywheel and governor. Flywheel works just like an energy reservoir while governor controls the speed by controlling the fuel supply.

**Chapter 15** deals with power transmission devices such as belt drive, chain drive, and gear drive. In belt drive, we discuss open and cross belt drives and their applications; in the chain drive, we provide a basic idea about the power transmission mechanisms; and in gear drive, we discuss different types of gears and working on gear trains.

**Chapter 16** covers other types of power transmission devices such as coupling and clutch. It also discusses the mechanisms of various types of braking systems. Clutch provides a flexibility to engage or disengage the engine from the load.

**Chapter 17** covers some of the important engineering materials and their mechanical properties such as tensile strength, hardness, toughness, ductility, malleability, etc. Some practical methods to measure the tensile strength, hardness, and toughness are also discussed.

**Chapter 18** demonstrates various types of measurements such as the measurement of pressure, velocity, flow, force, torque, etc. Also, some of the devices used in metrology have been introduced such as vernier caliper, screw gauge, sine bar, dial gauge and slip gauge.

**Chapter 19** deals with the mechanism of machining and working of various machine tools such as lathe, shaper and planer, drilling and boring, and milling operations.

**Chapter 20** describes the primary shaping (casting) and joining (welding) processes such as welding. In this chapter, sand casting and other casting processes with casting defects are discussed. Different conventional and non-conventional welding and allied processes with welding defects are also explained.

**Chapter 21** covers various forging operations, sheet metal processes, and powder metallurgy. These are the basic processes frequently used in mechanical workshops.

**Chapter 22** provides a basic idea of the numerical control machine, computer numerical control machine, and direct numerical control machines. Also, the basic concepts of automation and robotics have been discussed. These are the machines used in metal cutting with improved productivity and accuracy.

**Chapter 23** deals with heat treatment processes. In this chapter, the mechanism of controlling the mechanical properties by heating and cooling with different rates is discussed.

# Preface to the First Edition

---

In many institutions and universities, Basic Mechanical Engineering is a compulsory paper for the first year engineering students. This book covers a basic overview of several areas of mechanical engineering. The main purpose to teach Basic Mechanical Engineering to the non-mechanical students is to provide the knowledge of the basic mechanical operations and familiarize the students with the commonly used mechanical machines/instruments. It is broadly divided into three parts—thermal engineering, mechanical design, and manufacturing engineering.

In thermal engineering, we discuss various forms of energy transfer, laws of thermodynamics, steam properties and steam generators, fluid mechanics, turbines, internal combustion engines, heat transfer, refrigeration and air conditioning, compressors, etc. In mechanical design, we discuss the mechanism of working of machine elements such as belt drive, chain drive, gear drive, springs, CAM and follower, bushing and bearing, couplings, etc. Also, some basic concepts of centroid and moment of inertia, stress and strain, power transmission, etc have been discussed. In manufacturing engineering, we discuss basic manufacturing processes such as casting, welding, machining, machine tools (Lathe, Drilling, Boring, Slotting, Shaper, Planer, Milling, and Grinding Machines), powder metallurgy, sheet metal working, smithy and metrology and provide a basic idea of automation (NC, CNC, DNC) and robotics. Thus, the basic concepts of mechanical engineering are covered completely and hence this book will be useful to both mechanical as well as other engineering students. In this book, the author has tried to cover the maximum syllabi of all the major institutions/universities in India.

**Pravin Kumar**

## About the Author

---



Pravin Kumar obtained his Ph.D. from IIT Delhi and M.Tech. from Institute of Technology (BHU), Varanasi. Presently, he is working as a faculty in the Department of Mechanical Engineering, Delhi Technological University (Formerly Delhi College of Engineering). He has more than 16 years of teaching and research experience. He has been teaching Basic Mechanical Engineering for several years. He has also authored two more books—Industrial Engineering and Management, published by Pearson Education, and Fundamentals of Engineering Economics, published by Wiley India Pvt. Ltd. He has published more than 50 research papers in the National and International Journals and Conferences.



# Acknowledgements

---

I am thankful to my colleagues Dr Naokant Deo, K. Srinivas, Dr R.K. Singh, Prof. D.S. Nagesh, Prof. Naveen Kumar, Prof. R.K. Sinha, and Prof. Moin Ud Din (Ex-Pro-Vice Chancellor, DTU) for their motivation, encouragement, and moral support during writing of this book.

I am thankful to my Guru Prof. Ravi Shankar and Prof. Surendra S. Yadav for their inspiration and support. The second edition of *Basic Mechanical Engineering* has been improved based on the suggestions and constructive comments of the readers and the faculty of various engineering institutions who have read the first edition of the book. I am thankful to all those students and teachers for their suggestions and comments. I am also thankful to Prof. Yogesh Singh, Vice-Chancellor, DTU Delhi for the motivation and moral support.

I am grateful to my elder brothers Arun Kumar Singh and Pramod Kumar for their moral support and motivation to pursue my research and publish this work. I would like to thank my wife Dr Prerna Sinha and my sons Harshit and Arpit for their support, patience, and wholehearted participation in accomplishing this work. I am also grateful to all the well-wishers, whose names could not be mentioned here, for their direct and indirect support. I would also like to express my gratitude to my parents, father-in-law and mother-in-law, who remain a continuous source of inspiration.

Last but not least, I am immensely grateful to the Pearson Education, especially Harsha Singh and G. Sharmilee, for their continuous support during writing and editing process of the book. This book could not have attained its present form both in content and presentation without their active interest and direction.

**Pravin Kumar**

# Concepts of Thermodynamics and Properties of Gases

## Learning Objectives

*By the end of this chapter, the student will be able:*

- To describe the basic concepts of thermodynamics
- To state the laws of thermodynamics
- To apply the laws of thermodynamics for different engineering applications
- To state the gas laws and solve the related problems

## 1.1 ► INTRODUCTION

There are different forms of energy; all the energy cannot be used as a work. The convertibility of energy into work depends on its availability, i.e., how much energy can be converted into useful work. Thermodynamics is a branch of science and engineering that deals with interaction of energy mainly in the forms of heat and work. Thermodynamics is concerned with the thermal behavior of a matter and its interaction with other physical and chemical behavior of the matter. Broadly, thermodynamics is studied into two forms—Classical and Statistical. Classical thermodynamics is concerned with the macrostructure of matter. It addresses the gross characteristics of large aggregations of molecules and not the behavior of individual molecules. The microstructure of matter is studied in kinetic theory and statistical mechanics. Statistical thermodynamics is concerned with the microstructure of the matter and addresses behavior of individual molecules of the matter. In this chapter, only classical approach to thermodynamics has been discussed. Gases are very important part of engineering thermodynamics; therefore, to know the behavior of an ideal gas at standard temperature and pressure is very important. In this chapter, we have also discussed about the different gas laws and universal gas constants.

### Macroscopic Vs Microscopic Viewpoint of Thermodynamics

Macroscopic and Microscopic views are used to study the behavior of the matter. If the matter is studied about its behavior on the basis of certain amount or volume without consideration of its properties at the molecular level, it is known as macroscopic thermodynamics. If the matter is studied at its molecular level for its properties, it is known as microscopic thermodynamics. Both, macroscopic and microscopic thermodynamics are discussed in the following sections in detail.

#### Macroscopic (Classical Thermodynamics)

- ▶ In this approach, a certain quantity or volume of the matter is considered, without taking into account the events occurring at the molecular level.
- ▶ This approach to the study of thermodynamic properties does not require knowledge of the behavior of individual particles.
- ▶ It is only concerned with the effects of the action of many combined molecules, and these effects can be perceived by human senses.
- ▶ The macroscopic observations are completely independent of the assumptions regarding the nature of matter.

#### Microscopic (Statistical Thermodynamics)

- ▶ From the microscopic viewpoint, it is assumed that matter is composed of a large number of small molecules and atoms.
- ▶ This approach to the study of thermodynamics requires knowledge of the behavior of individual particles.
- ▶ It is concerned with the effects of the action of many molecules, and these effects cannot be perceived by human senses.
- ▶ The microscopic observations are completely dependent on the assumptions regarding the nature of matter.

## 1.2 ▶ IMPORTANT TERMINOLOGIES USED IN THERMODYNAMICS

**Thermodynamics:** It is the field of thermal engineering that studies the properties of systems that have a temperature and involve the laws that govern the conversion of energy from one form to another, the direction in which heat will flow, and the availability of energy to do the work.

**Mass and Force:** Mass is one of the fundamental dimensions, like time, it cannot be defined in terms of other dimensions. Much of our intuition of what mass is followed from its role in Newton's second law of motion

$$F = M \cdot f$$

In this relationship, the force  $F$  required to produce a certain acceleration  $f$  of a particular body is proportional to its mass  $M$ .

**Volume:** The familiar property, volume, is formally defined as the amount of space occupied in three-dimensional space. The *SI* unit of volume is cubic meters ( $m^3$ ).

**Pressure:** For a fluid system, the pressure is defined as the normal force exerted by the fluid on a solid surface or a neighboring fluid element, per unit area. From a molecular point of view, the pressure exerted by a gas on the walls of its container is a measure of the rate at which the momentum of the molecules colliding with the wall is changed.

The *SI* unit for pressure is a Pascal,

$$1 \text{ Pa} = 1 \text{ N/m}^2$$

Also commonly used unit is bar, which is defined as

$$1 \text{ bar} = 10^5 \text{ Pa} = 10^5 \text{ N/m}^2$$

As a result of some practical devices measuring pressures relative to the local atmospheric pressure, we distinguish between gauge pressure and absolute pressure. Gage pressure is defined as

$$P_{\text{gauge}} = P_{\text{abs}} + P_{\text{atm}}$$

**System:** System is the fixed quantity of matter and/or the region that can be separated from everything else by a well-defined boundary/surface. Thermodynamic system is the system on which thermodynamic investigation is done. The surface separating the system and surroundings is known as the *control surface* or *system boundary*. The control surface may be movable or fixed. Everything beyond the system is the *surroundings*. A system of fixed mass is referred to as a closed system. When there is flow of mass through the control surface, the system is called an *open system*. An *isolated system* is a closed system that does not interact in any way with its surroundings.

## Properties of a System

Any characteristic of a system by which its physical condition is defined called as property. Pressure, temperature, volume, mass, viscosity, thermal conductivity, modulus of elasticity, thermal expansion coefficient, electrical resistivity, velocity, elevation, etc.

---

## 4 Chapter 1

are the examples of the properties of a system. Properties may be either *intensive* or *extensive*.

- ▶ Intensive properties are those that are independent of the mass of a system, such as temperature, pressure, and density.
- ▶ Extensive properties are those whose values depend on the size or extent of the system. Total mass, total volume, and total momentum are some examples of extensive properties.
- ▶ Extensive properties per unit mass are called specific properties.

**State:** At any instant of time, the condition of a system is called a *state*. The state at a given instant of time is defined by the properties of the system such as pressure, volume, temperature, etc. A *property* is any quantity whose numerical value depends on the state but not on the history of the system. There are two types of properties—extensive and intensive. Extensive properties depend on the size or extent of the system. Volume, mass, energy, and entropy are examples of extensive properties. An extensive property is additive in the sense that its value for the whole system equals the sum of the values for its molecules. Intensive properties are independent of the size or extent of the system. Pressure and temperature are examples of intensive properties.

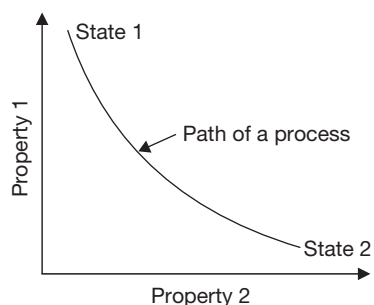
### State and Equilibrium

When no change occurs in the system properties, at this point, all the properties can be measured or calculated throughout the entire system. The properties at this static condition describe the state of the system. At a given state, all the properties of a system have fixed values. If the value of even one property changes, the state will change to a different one. The word equilibrium implies a state of balance. In an equilibrium state, there are no unbalanced potentials/forces within the system. When a system is isolated from its surroundings, the system experiences no change in it. There are mainly three types of equilibrium, and a system is not in thermodynamic equilibrium unless the conditions of all the three relevant types of equilibrium are satisfied:

- (a) Thermal equilibrium: Temperature should be same throughout the system.
- (b) Mechanical equilibrium: Unbalanced forces should be absent, e.g., change in pressure.
- (c) Chemical equilibrium: No chemical reaction and mass transfer occur.

**Change in State:** Thermodynamic system undergoes changes due to flow of mass and energy. The mode in which the changes in the state of a system take place is known as process such as isobaric (constant pressure) process, isochoric (constant volume) process,

isothermal (constant temperature) process, adiabatic (constant entropy) process, etc. The path is the loci of series of state changes from initial state to final state during a process. The changes in state and path of a process are shown in Figure 1.1. The thermodynamic cycle refers to the sequence of processes in which initial and final states of the system are same. For example, Otto cycle, Diesel cycle, Dual cycle, Joule cycle, Rankine cycle, Carnot cycle, etc. have identical initial and final states.



**FIGURE 1.1**

Change in State with a Process

**Process:** Two states are identical if, and only if, the properties of the two states are same. When any property of a system changes its value, there is a change in the state, and the system is said to undergo a *process*. When a system from a given initial state goes into a sequence of processes and finally returns to its initial state, it is said to have undergone a *cycle*.

**Phase:** Phase refers to a quantity of matter that is homogeneous throughout in its chemical composition and physical structure. A system can contain one or more phases. A mixture of water and water vapor has two phases. A pure substance is one that is uniform and invariable in chemical composition. A pure substance can exist in more than one phase, but its chemical composition must be the same in each phase. For example, if liquid water and water vapor form a system with two phases, the system can be regarded as a pure substance because each phase has the same composition.

**Equilibrium:** In thermodynamics the concept of equilibrium includes not only a balance of forces, but also a balance of other influencing factors, such as thermal equilibrium, pressure equilibrium, phase equilibrium, etc. To observe a thermodynamic equilibrium in a system, one may test it by isolation of the system from its surroundings and watch for changes in its observable properties. If no change takes place, it may be said that the system is in equilibrium. The system can be in an equilibrium state. When a system is isolated, it cannot interact with its surroundings; however, its state can change as a consequence of spontaneous changes occurring internally as its intensive properties, such as temperature and pressure, tend toward uniform values. When all such changes cease, the system is in equilibrium. At equilibrium, temperature and pressure are uniform throughout. If gravity is significant, a pressure variation with height can exist, as in a vertical column of liquid.

## Systems and Control Volumes

A system is defined as a *quantity of matter or a region in space considered for study*. The mass or region outside the system is called the *surroundings*. The real or imaginary surface that

separates the system from its surroundings is called the boundary. The boundary of a system can be *fixed or movable*. *The boundary is the* contact surface shared by both the systems and the surroundings. The boundary has zero thickness, and thus it can neither contain any mass nor occupy any volume in space.

## Open and Closed Systems

Systems may be considered as closed, open, and isolated depending on the flow of mass and energy. A closed system consists of a fixed amount of mass, and no mass can cross its boundary. But energy, in the form of heat or work, can cross the boundary; and the volume of a closed system is not to be fixed necessarily. When the energy is also not allowed to cross the boundary, that system is called an isolated system. In an open system or a control volume, both mass and energy can cross the boundary of a control volume. In general, any arbitrary region in space can be selected as a control volume. The boundaries of a control volume are called a control surface, and they can be real or imaginary.

## Zeroth Law of Thermodynamics

*It is law of thermal equilibrium, which states that if a system A is in thermal equilibrium with systems B and C, then systems B and C will be in thermal equilibrium.*

Zeroth law of thermodynamics is the basis of temperature measurement. To measure the temperature, a reference body is used, and a certain physical characteristic of this body, which changes with temperature is selected. The change in the selected characteristic may be taken as an indication of change in temperature. The selected characteristic is called the thermometric property, and the reference body, which is used in the determination of temperature is called the thermometer. A commonly used thermometer consists of a small amount of mercury in an evacuated capillary tube. In this case, the extension of the mercury in the tube is used as the thermometric property.

**Quasi-static Process:** When a process proceeds in such a way that the system remains infinitesimally close to an equilibrium state at all times, it is called a quasi static process. A quasi-static process can be understood as a sufficiently slow process that allows the system to adjust internally so that properties in one part of the system do not change any faster than those at other parts.

**Temperature:** Temperature is a property of a substance by which it can be differentiated from other substance in terms of degree of hot or cold. A scale of temperature independent of the thermometric substance is called a thermodynamic temperature scale. The Celsius temperature scale (centigrade scale) uses the degree Celsius ( $^{\circ}\text{C}$ ), which has the same magnitude as the Kelvin. Thus, temperature differences are identical on both scales. However, the

zero point on the Celsius scale is shifted to 273.15 K, as shown by the following relationship between the Celsius temperature and the Kelvin temperature:

$$^{\circ}\text{C} = \text{K} - 273.15$$

Two other temperature scales are commonly used are the Rankine and Fahrenheit scale, the various relationships between temperature scales are as shown below:

$$\text{R} = 1.8 \text{K}$$

$$\text{F} = \text{R} - 459.67$$

$$\text{F} = 1.8^{\circ}\text{C} + 32$$

**Internal Energy:** The Internal Energy ( $U$ ) of a system is the total energy content of the system. It is the sum of the kinetic, potential, chemical, electrical, and all other forms of energy possessed by the atoms and molecules of the system.  $U$  is path independent and depends only on temperature for an ideal gas. Internal energy may be stored in the system in the following forms:

- ▶ Kinetic energy of molecules.
- ▶ Molecular vibrations and rotations.
- ▶ Chemical bonds that can be released during a chemical reaction.
- ▶ Potential energy of the constituents of the system.

**Work:** Work in thermodynamics may be defined as any quantity of energy that flows across the boundary between the system and surroundings which can be used to change the height of a mass in the surroundings.

**Heat:** Heat is defined as the quantity of energy that flows across the boundary between the system and surroundings because of a temperature difference between system and surroundings. There are following characteristics of heat:

- ▶ Heat is transitory and appears during a change in state of the system and surroundings. It is not a point function.
- ▶ The net effect of heat is to change the internal energy of the system and surroundings in accordance to first law.
- ▶ If heat is transferred to the system, it is positive and if it is transferred from the system it is negative.

**Enthalpy:** Enthalpy,  $h$ , of a substance is defined as  $h = u + PV$ . It is intensive properties of a substance and measured in terms of kJ/kg.



## 1.3 ► SPECIFIC HEAT CAPACITY

### 1.3.1 Specific Heat at Constant Volume ( $C_v$ )

The rate of change of internal energy with respect to absolute temperature at constant volume is known as specific heat at constant volume ( $C_v$ ).

$$C_v = \left( \frac{\partial u}{\partial T} \right)_v; \text{ Where } u \text{ is internal energy and } T \text{ is absolute temperature.}$$

$$Q = \Delta u + W = \Delta u + PdV = \Delta u = \int_{T_1}^{T_2} C_v dT$$

Enthalpy is sum of internal energy and product of pressure and volume, i.e.,  $h = u + PV$ . But,

$$Q = \partial u + PdV = \partial u + \partial(PV) = \partial(u + PV) = \partial h$$

since  $dP = 0$  at constant pressure

### 1.3.2 Specific Heat at Constant Pressure ( $C_p$ )

The rate of change of enthalpy with respect to absolute temperature when pressure is constant is known specific heat at constant pressure ( $C_p$ ).

$$C_p = \left( \frac{\partial h}{\partial T} \right)_p; \text{ for a constant pressure process.}$$

$$\partial h = \partial Q = \int_{T_1}^{T_2} C_p dT$$

#### EXAMPLE 1.1

The property of a substance is given as

$$u = 186 + 0.718t$$

$$pv = 0.287(t + 273)$$

where  $u$  is the specific internal energy ( $\text{kJ/kg}$ ),  $t$  is the temperature in  $^\circ\text{C}$ ,  $p$  is pressure in  $\text{kN/m}^2$ , and  $v$  is specific volume ( $\text{m}^3/\text{k}$ ). Find the  $C_v$  and  $C_p$  of the substance.

#### SOLUTION

$$C_v = \frac{\delta u}{\delta t} = 0.718 \text{ kJ/kg}$$

$$C_p = \frac{\delta h}{\delta t} = \frac{\delta(u + pv)}{\delta t} = \frac{\delta u}{\delta t} + \frac{\delta(pv)}{\delta t} = 0.718 \text{ kJ/kgK} + 0.287 \text{ kJ/kgK} = 1.005 \text{ kJ/kgK}$$

### 1.3.3 Relationship Between $C_p$ and $C_v$

The specific heat capacity of a gas is the amount of heat required to raise the temperature by one degree Celsius of unit mass of the gas. We will use here specific values of the state variables (of the variable divided by the mass of the substance). The value of the constant is different for different materials and depends on the process. It is not a state variable.

If we are considering a gas, it is most convenient to use forms of the thermodynamic equations based on the enthalpy of the gas. From the definition of enthalpy:

$$h = u + pv$$

where  $h$  is the specific enthalpy,  $p$  is the pressure,  $v$  is the specific volume, and  $u$  is the specific internal energy. During a process, the values of these variables change. Let's denote the change by  $\Delta$ . For a constant pressure process the enthalpy equation becomes:

$$\Delta h = \Delta u + p\Delta v$$

The enthalpy, internal energy, and volume are all changed, but the pressure remains the same. From our derivation of the enthalpy equation, the change of specific enthalpy is equal to the heat transfer for a constant pressure process:

$$\Delta h = c_p \Delta T$$

where  $\Delta T$  is the change of temperature of the gas during the process, and  $c$  is the specific heat capacity. We have added a subscript  $p$  to the specific heat capacity at a constant pressure process.

The equation of state of a gas relates the temperature, pressure, and volume through a gas constant  $R$ . The gas constant is derived from the universal gas constant, but has a unique value for every gas.

$$pv = RT$$

For a constant pressure process:

$$p\Delta v = R\Delta T$$

Now let us consider a constant volume process with a gas that produces exactly the same temperature change as the constant pressure process that we have been discussing. Then the first law of thermodynamics tells us:

$$\Delta u = \Delta q - \Delta w$$

where  $q$  is the specific heat transfer and  $w$  is the work done by the gas. For a constant volume process, the work is equal to zero. And we can express the heat transfer as a constant times the change in temperature. This gives:

$$\Delta u = c_v \Delta T$$

where  $\Delta T$  is the change of temperature of the gas during the process, and  $c$  is the specific heat capacity. We have added a subscript  $v$  to the specific heat capacity a constant volume process. Even though the temperature change is the same for this process and the constant pressure process, the value of the specific heat capacity is different.

Because we have selected the constant volume process to give the same change in temperature as our constant pressure process, we can substitute the expression given above for  $\Delta u$  into the enthalpy equation. *In general, we can't make this substitution because a constant pressure process and a constant volume process produce different changes in temperature.* If we substitute the expressions for  $\Delta u$ ,  $p\Delta v$ , and  $\Delta h$  into the enthalpy equation we obtain:

$$c_p \Delta T = c_v \Delta T + R \Delta T$$

Dividing the above equation by  $\Delta T$ , we get

$$c_p = c_v + R$$

The specific heat constants for constant pressure and constant volume processes are related to the gas constant for a given gas. This rather remarkable result has been derived from thermodynamic relations, which are based on observations of physical systems and processes. Using the kinetic theory of gases, this same result can be derived from considerations of the conservation of energy at a molecular level.

We can define an additional variable called the specific heat ratio, which is given the Greek symbol  $\gamma$ , which is equal to  $c_p$  divided by  $c_v$ :

$$\gamma = c_p / c_v$$

$\gamma$  is a number whose value depends on the state of the gas. For air,  $\gamma = 1.4$  for standard conditions.

For **monoatomic gas**,  $\gamma = C_p / C_v = 5/3 = 1.66$

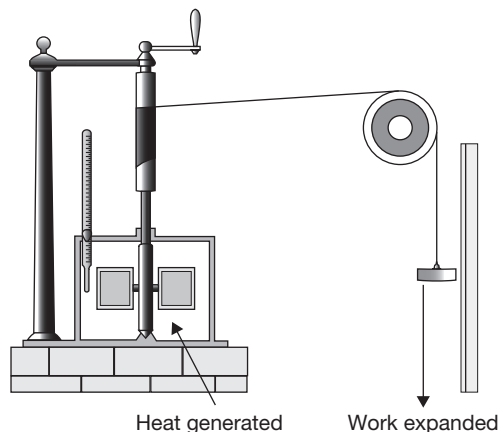
For **diatomic gas**,  $\gamma = C_p / C_v = 7/5 = 1.40$

For **triatomic gas**,  $\gamma = C_p / C_v = 8/6 = 1.33$

## 1.4 ► THE FIRST LAW OF THERMODYNAMICS

### 1.4.1 Mechanical Equivalent of Heat

The *mechanical equivalent of heat* is a concept that has an important part in the development and acceptance of the conservation of energy and the establishment of the science of thermodynamics in the 19th century. The concept stated that motion and heat are mutually



**FIGURE 1.2**

Mechanical Equivalent of Heat

interchangeable and that in every case, a given amount of work would generate the same amount of heat, provided the work done is totally converted to heat energy.

### *First Law of Thermodynamics*

The first law of thermodynamics is equivalent to the law of conservation of energy. It deals with the transformation of heat energy into work and vice versa. For closed systems, energy can be transferred by work and heat transfer. In thermodynamics, the term *work* denotes a means for transferring energy. Work done by a system is considered positive— $W > 0$ . Work done on a system is considered negative— $W < 0$ . Heat given to a system is considered as positive— $Q > 0$ ; Heat exhaust by a system is considered as negative— $Q < 0$ . The heat generation by the work done on the system is shown in Figure 1.2. A weight is moving in downward direction which rotates the steerer. Due to the rotation of steerer in the water, heat is generated.

*When a small amount of work ( $dw$ ) is supplied to a closed system undergoing a cycle, the work supplied will be equal to the heat transfer or heat produced ( $dQ$ ) in the system.*

$$\oint dw = J \oint dQ$$

Where  $J$  is a joule constant; 1 Calorie = 4.18 Joule

*If the  $Q$  amount of heat is given to a system undergoing a change of state and  $W$  is the work done by the system and transferred during the process, the net energy ( $Q - W$ ) will be stored in the system named as internal energy of simply the energy of the system ( $\Delta U$ ).*

$$Q - W = \Delta U$$

**Sign Convention:** The convention is adopted that  $Q$  indicates the heat added to the system and  $W$  the work done by it. Thus,

$dQ > 0$ , heat added to system or system absorbs heat.

$dQ < 0$ , heat removed from system or system rejects heat.

$dW > 0$ , work is done by the system.

$dW < 0$ , work is done on the system.

$\Delta U > 0$ , internal energy of the system increases.

$\Delta U < 0$ , internal energy of the system decreases.

### *First Kind of Perpetual Motion Machine (PMM1)*

The machine which would continuously supply mechanical work without some other form of energy disappearing simultaneously. Such a fictitious machine is called first kind of perpetual motion machine (PMM1). PMM1 is impossible. It is a fictitious machine.

#### **1.4.2 Internal Energy**

Energy exists in various forms such as thermal, mechanical, kinetic, potential, electric, magnetic, chemical, and nuclear, etc. In thermodynamic, it is considered that the various forms

of energy make up total energy of a system. This total energy can be represented into two groups—macroscopic and microscopic. The macroscopic forms of energy are those a system possesses as a whole with respect to some outside reference frame, such as kinetic and potential energies. The microscopic forms of energy are those related to the molecular structure of a system and the degree of the molecular activity, and they are independent of outside reference frames. *The sum of all the microscopic forms of energy is called the internal energy of a system and is denoted by  $U$ .* The macroscopic energy of a system is related to motion and the influence of some external factors such as gravity, magnetism, electricity, surface tension, etc.

The energy that a system possesses as a result of its motion relative to some reference frame is called kinetic energy. The energy that a system possesses as a result of its elevation in a gravitational field is called potential energy. In the absence of the effect of external factors, the total energy of a system consists of the kinetic, potential, and internal energies;

i.e.,

$$E = K.E + P.E + U = \frac{1}{2}mv^2 + mgh + U$$

where  $m$  is the mass of the system,  $v$  is the velocity of the system,  $h$  is height from reference point, and  $U$  is the internal energy of the system. The change in the total energy  $E$  of a stationary system is equal to the change in its internal energy,  $U$  since the changes in kinetic and potential energies in the stationary close system are negligible.

### 1.4.3 Physical Interpretation of Internal Energy

Internal energy can be defined as the sum of all the microscopic forms of energy of a system. It is related to the molecular structure and the degree of activities at the molecular level and can be viewed as the sum of the kinetic and potential energies of the molecules. Let us consider a system for analysis of internal energy at the molecular level. Due to different type of movements of molecules, such as translational, rotational and vibrational, the kinetic energy in the system is developed. The vibrational motion of the molecules becomes more significant at higher temperature. If we analyze the system at the atomic level, the fundamental particles rotate in their orbits around the nucleus and also spin about their own axis. Thus, rotational kinetic energy and spin energy are associated with the system. The part of internal energy associated with the kinetic energy is known as sensible energy and proportional to the temperature of the system. At higher temperature, degree of activity at the molecular level will be larger and system will have higher internal energy.

Internal energy may be presented in the form of binding force at the atomic level. If external energy is supplied to break the bond and to change the phase from solid to liquid or liquid to solid, a certain amount of energy is stored as latent energy. This latent energy represents the internal energy of the system. Similarly, it may be associated with nuclear and some other forms of energy in the system.

#### 1.4.4 Energy Transfer Across the System Boundary (Heat and Work)

Energy transfer across the boundary of a closed system may occur in the form of heat and work. When a closed system is left in a medium of different temperature, energy transfer takes place between the system and the surroundings until thermal equilibrium is reached. The direction of energy transfer is always from the higher temperature side to the lower temperature side. Once the temperature equilibrium is established, energy transfer stops. In the processes described above, energy is said to be transferred in the form of heat. Heat is defined as the form of energy that is transferred between two systems or between a system and its surroundings, by virtue of a temperature difference.

During adiabatic process heat transfer is negligible. A process can be adiabatic when either the system is well insulated so that only a negligible amount of heat can pass through the boundary, or both the system and the surroundings are at the same temperature. Even though there is no heat transfer during an adiabatic process, the energy content and thus the temperature of a system can still be changed by other means such as work, i.e., the heat can be transformed into work. If the energy crossing the boundary of a closed system is not heat, it must be in the form of work. Heat is easy to recognize as its driving force is a temperature difference between the system and its surroundings. Then we can simply say that an energy interaction that is not caused by a temperature difference between a system and its surroundings is work.

#### *Sign Conventions for Heat and Work Interaction*

Heat and work are directional quantities, and thus the complete description of a heat or work interaction requires the specification of both the magnitude and direction. One way of doing that is to adopt a sign convention. The generally accepted formal sign convention for heat and work interactions is as follows:

- (a) Heat transfer to a system and work done by a system are positive;
- (b) Heat transfer from a system and work done on a system are negative.

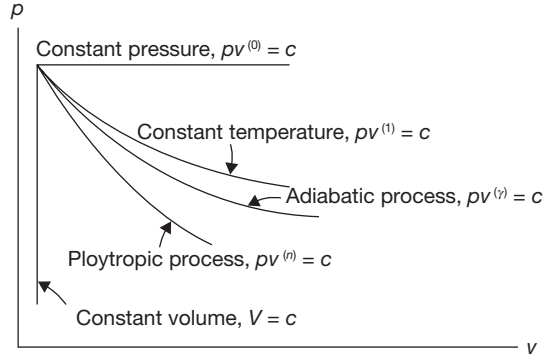
#### *Similarity between Heat and Work*

Heat and work are energy transfer mechanisms between a system and its surroundings. Some of the similarities between heat and work can be given below as:

- (a) Heat and work are boundary phenomena.
- (b) Systems possess energy, but not the heat or work.
- (c) Both are associated with a process, not a state.
- (d) Both are path functions.

### 1.4.5 Non-flow Processes

The various non-flow processes and their characteristics are shown in Figure 1.3.



**FIGURE 1.3**  
Non-flow Processes

#### Constant Volume Process

In this process, volume remains constant, i.e.,  $\Delta V = 0$ . This is also known as isochoric process. From first law of thermodynamics:

$$Q = \Delta U + W$$

$$W = \int p dV = 0$$

$$Q = \Delta U = m(u_2 - u_1) = m \times c_v dT = m \times c_v (T_2 - T_1) \text{ kJ}$$

#### Constant Pressure Process

In this process, pressure remains constant, i.e.,  $\Delta p = 0$ . This is also known as isobaric process. The work done from state 1 to state 2.

$$W = p dV = p(V_2 - V_1)$$

From first law of thermodynamics

$$\int_1^2 dQ = \int_1^2 dU + \int_1^2 dW$$

$$Q_{1-2} = mc_v (T_2 - T_1) + p(V_2 - V_1)$$

$$= m \frac{R}{(\gamma - 1)} (T_2 - T_1) + mR(T_2 - T_1)$$

$$= \frac{\gamma mR (T_2 - T_1)}{(\gamma - 1)}$$

### Constant Temperature Process

In this process, temperature remains constant, i.e.,  $\Delta T = 0$ . This is also known as isothermal process.

$$PV = P_1 V_1 = P_2 V_2 = \text{Constant}$$

$$\text{Work, } W_{1-2} = \int_1^2 P \cdot dV = \int_1^2 \frac{P_1 V_1}{V} dV = P_1 V_1 \ln \left( \frac{V_2}{V_1} \right) = P_1 V_1 \ln \left( \frac{P_1}{P_2} \right) = nRT \ln \left( \frac{P_1}{P_2} \right)$$

From first law of thermodynamics

$$\int_1^2 dQ = \int_1^2 dU + \int_1^2 dW$$

$$Q_{1-2} = W_{1-2} + (U_2 - U_1) = W_{1-2} + 0$$

$$U_2 - U_1 = mc_v (T_2 - T_1) = 0 \text{ as } T_1 = T_2$$

### Adiabatic Process

In this process, heat transfer is equal to zero.

*Work done during adiabatic process*

$$W_{1-2} = \frac{p_1 V_1 - p_2 V_2}{\gamma - 1}$$

*From the first law of thermodynamics*

$$\int_1^2 dQ = \int_1^2 dU + \int_1^2 dW$$

$$Q_{1-2} = (U_2 - U_1) + \frac{p_1 V_1 - p_2 V_2}{\gamma - 1}$$

$$0 = mc_v (T_2 - T_1) + \frac{p_1 V_1 - p_2 V_2}{\gamma - 1}$$

$$W_{1-2} = mc_v (T_2 - T_1)$$

### Polytropic Process

In this process, the law is governed by  $PV^n = \text{constant}$ .

*Work done during adiabatic process*

$$W_{1-2} = \frac{p_1 V_1 - p_2 V_2}{n - 1}$$



From the first law of thermodynamics

$$\int_1^2 dQ = \int_1^2 dU + \int_1^2 dW$$

$$Q_{1-2} = (U_2 - U_1) + \frac{p_1 V_1 - p_2 V_2}{n-1}$$

$$Q_{1-2} = mc_v (T_2 - T_1) + \frac{mR(T_1 - T_2)}{n-1}$$

$$Q_{1-2} = mc_v (T_2 - T_1) + \frac{mc_v (\gamma - 1)(T_1 - T_2)}{n-1}$$

$$Q_{1-2} = mc_v (T_2 - T_1) \frac{(\gamma - n)}{(1 - n)}$$

### EXAMPLE 1.2

The initial pressure and temperature of 1 mole of an ideal gas are 1 MPa and 380 K respectively. It is heated at constant pressure till the temperature is doubled and then is allowed to expand reversibly and adiabatically till the temperature is reduced to 380 K as shown in Figure 1.4, find the heat transferred and work interaction. If it is required to restore the system from final state to the original state by a reversible isothermal path, determine the amount of work to be done on the system.

### SOLUTION

$P$ - $V$  diagram for the process is shown in Figure 1.4.

Let  $P_1 = 1 \text{ MPa}$ ,  $T_1 = 380 \text{ K}$ ,  $T_2 = 2T_1 = 2 \times 380 \text{ K} = 760 \text{ K}$

Since from 1 to 2 pressure is constant

$$\frac{V_1}{T_1} = \frac{V_2}{T_2} = \frac{V_2}{2T_1} \Rightarrow V_2 = 2V_1$$

$$Q_{1-2} = \Delta h = h_2 - h_1 = C_p(T_2 - T_1) = C_p(2T_1 - T_1) = C_p T_1$$

$$W_{1-2} = \int_1^2 PdV = P_1(V_2 - V_1) = P_1 V_1 = RT_1$$

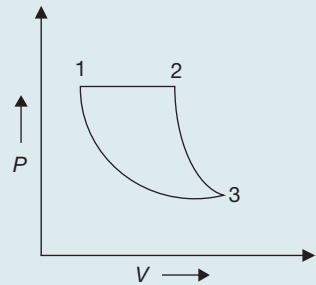
Change in internal energy in the process 2 to 3,

$$u_3 - u_2 = C_v(T_3 - T_2) = Q_{2-3} - W_{2-3} \quad (\text{Since } Q_{2-3} = 0 \text{ due to adiabatic process})$$

$$W_{2-3} = C_v(T_2 - T_3) = C_v(2T_1 - T_1) = C_v T_1 \quad (\text{Since } T_3 = T_1 \text{ and } T_2 = 2T_1)$$

For the process 2 to 3

$$\frac{T_2}{T_3} = \left(\frac{V_3}{V_2}\right)^{\gamma-1} \quad \text{or} \quad 2 = \left(\frac{V_3}{V_2}\right)^{1.4-1} \quad \text{or} \quad \frac{V_3}{V_2} = 5.65$$



**FIGURE 1.4**

$P$ - $V$  Diagram

$$Q = Q_{1-2} + Q_{2-3} = C_p T_1 = \frac{R \gamma T_1}{\gamma - 1} = \frac{8.314 \text{ J/mole.K} \times 1.4 \times 380 \text{ K}}{1.4 - 1} = 11.05 \text{ kJ}$$

here  $Q_{2-3} = 0$ ,

$$W = W_{1-2} + W_{2-3} = RT_1 + C_v T_1 = C_p T_1 = 11.05 \text{ MJ}$$

For the reversible isothermal process

$$W = \int_3^1 P dV = RT_1 \ln \log \frac{V_1}{V_3} = RT_1 \ln \log \frac{V_1}{V_2} \left( \frac{V_2}{V_3} \right) = 8.314 \text{ J/mole.K} \times 380 \text{ K} \ln \left( \frac{1}{2 \times 5.65} \right) = -7.66 \text{ kJ}$$

### EXAMPLE 1.3

A system undergoes the cyclic process a-b-c-d-e. The values of  $Q$ ,  $W$ , and  $\Delta u$  for the individual process are as follows, find the heat transferred in the cyclic process:

Process	$Q$ (kJ)	$\Delta u$ (kJ)	$W$ (kJ)
a-b	-	-510	310
b-c	410	-	-510
c-d	510	610	-
d-e	-	-	810

### SOLUTION

Process a-b:  $Q = \Delta u + W = -510 \text{ kJ} + 310 \text{ kJ} = -200 \text{ kJ}$  (Heat liberated).

Process b-c:  $Q = \Delta u + W \Rightarrow 410 \text{ kJ} = \Delta u - 510 \text{ kJ}$  or  $\Delta u = 920 \text{ kJ}$

Process c-d:  $Q = \Delta u + W \Rightarrow W = Q - \Delta u = 510 \text{ kJ} - 610 \text{ kJ} = -100 \text{ kJ}$

(Work done on system)

In a cyclic process  $\int \Delta u = 0 \Rightarrow \Delta u_{ab} + \Delta u_{bc} + \Delta u_{cd} + \Delta u_{de}$

$$-510 \text{ kJ} + 920 \text{ kJ} + 610 \text{ kJ} + \Delta u_{de} = 0 \Rightarrow \Delta u_{de} = -1,020 \text{ kJ}$$

$$Q = \Delta u + W = -1,020 \text{ kJ} + 810 \text{ kJ} = -210 \text{ kJ} \text{ (Heat liberated)}$$

### EXAMPLE 1.4

There is a cylinder-piston system in which pressure is a function of volume,  $P = x + yV$ , and internal energy is given by  $u = 36 + 3.16 PV$ , where  $u$  is in  $\text{kJ}$ ,  $P$  is in  $\text{kN/m}^2$ ,  $V$  is in  $\text{m}^3$ . If gas changes state from  $150 \text{ kN/m}^2$  and  $0.02 \text{ m}^3$  to  $350 \text{ kN/m}^2$  and  $0.04 \text{ m}^3$ . Find the heat and work interaction.

**SOLUTION**

$$\Delta u = u_2 - u_1 = 3.16(P_2V_2 - P_1V_1) = 3.16(350 \text{ kN/m}^2 \times 0.04 \text{ m}^3 - 150 \text{ kN/m}^2 \times 0.02 \text{ m}^3) \\ = 34.76 \text{ kJ}$$

$$P = x + yV$$

$$150 \text{ kN/m}^2 = x + y \times 0.02 \text{ m}^3$$

$$350 \text{ kN/m}^2 = x + y \times 0.04 \text{ m}^3$$

On solving these two equations, we get  $x = -50 \text{ kN/m}^2$  and  $y = 10,000 \text{ kN/m}^2$

$$W_{1-2} = \int_{V_1}^{V_2} PdV = \int_{V_1}^{V_2} (x + yV)dV = x(V_2 - V_1) + y \frac{V_2^2 - V_1^2}{2} = 5 \text{ kJ}$$

$$Q_{1-2} = \Delta u + W_{1-2} = 34.76 \text{ kJ} + 5 \text{ kJ} = 39.76 \text{ kJ}$$

**EXAMPLE 1.5**

Calculate the quantities of work if initial pressure and volume are 15 bar and  $15 \text{ m}^3$  and final volume  $25 \text{ m}^3$ . The process is non-flow reversible as (i)  $P = \text{constant}$ ; (ii)  $V = \text{constant}$ ; (iii)  $PV = \text{constant}$ ; (iv)  $PV^n = \text{constant}$ , where  $n = 1.3$ ; and (v)  $PV^\gamma = \text{constant}$ , where  $\gamma = 1.4$ .

**SOLUTION**

(i)  $P = \text{constant}$

$$W = \int_{V_1}^{V_2} PdV = P(V_2 - V_1) = 15 \times 10^2 \text{ kPa} (25 \text{ m}^3 - 15 \text{ m}^3) = 15 \times 10^3 \text{ kJ}$$

(ii)  $V = \text{constant}$

$$W = \int_{V_1}^{V_2} PdV = 0$$

(iii)  $PV = \text{constant} = K$

$$W = \int_{V_1}^{V_2} PdV = \int_{V_1}^{V_2} \frac{K}{V} dV = P_1V_1 \ln \frac{V_2}{V_1} = 15(10^2) \text{ kPa} \times 15 \text{ m}^3 \ln \frac{25 \text{ m}^3}{15 \text{ m}^3} = 11.49 \times 10^3 \text{ kJ}$$

(iv)  $PV^n = \text{constant} = K$

$$W = \int_{V_1}^{V_2} PdV = \int_{V_1}^{V_2} \frac{K}{V^n} dV = \int_{V_1}^{V_2} KV^{-n} dV = P_1V_1 \left[ \frac{V^{1-n}}{1-n} \right]_1^2 = \frac{P_1V_1 - P_2V_2}{n-1}$$

$$P_2 = \frac{P_1V_1^n}{V_2^n} = 15 \text{ bar} \times \frac{(15 \text{ m}^3)^{1.3}}{(25 \text{ m}^3)^{1.3}} = 7.72 \text{ bar}$$

$$W = \frac{15(10^2) \text{ kPa} \times 15 \text{ m}^3 - 7.72(10^2) \text{ kPa} \times 25 \text{ m}^3}{1.3 - 1} = 10.667 \times 10^3 \text{ kJ}$$

$$(v) \quad PV^n = \text{constant} = K$$

$$W = \int_{V_1}^{V_2} PdV = \int_{V_1}^{V_2} \frac{K}{V^\gamma} dV = \int_{V_1}^{V_2} KV^{-\gamma} dV = P_1 V_1 \left[ \frac{V^{1-\gamma}}{1-\gamma} \right]_1^2 = \frac{P_1 V_1 - P_2 V_2}{\gamma - 1}$$

$$P_2 = \frac{P_1 V_1^\gamma}{V_2^\gamma} = 15 \text{ bar} \times \frac{(15 \text{ m}^3)^{1.4}}{(25 \text{ m}^3)^{1.4}} = 7.336 \text{ bar}$$

$$W = \frac{15(10^2) \text{ kPa} \times 15 \text{ m}^3 - 7.336(10^2) \text{ kPa} \times 25 \text{ m}^3}{1.4 - 1} = 10.4 \times 10^3 \text{ kJ}$$

### EXAMPLE 1.6

A cylinder consists of a frictionless spring loaded piston; the pressure of gas at an instant is 5 bar. The spring force exerted on the piston is proportional to the volume of gas. Also, additional atmospheric pressure of 1 bar acts on the spring side of piston as shown in Figure 1.5. Calculate the work done by the gas in expansion from  $0.2 \text{ m}^3$  to  $0.8 \text{ m}^3$ .

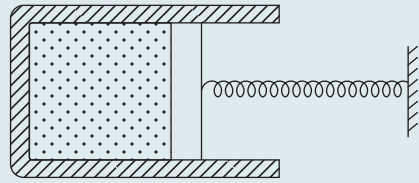


FIGURE 1.5

Cylinder Piston Arrangement

### SOLUTION

The pressure exerted on spring by the piston,

$$P_s = \text{Pressure of gas inside the cylinder} - \text{Atmospheric pressure} \\ = 5 \text{ bar} - 1 \text{ bar} = 4 \text{ bar}$$

$$\text{Spring displacement} = \frac{\text{Change in volume}}{\text{Area}} = \frac{0.8 \text{ m}^3 - 0.2 \text{ m}^3}{A} = \frac{0.6 \text{ m}^3}{A}$$

$$\text{Spring constant, } K = \frac{\text{Spring force}}{\text{Spring displacement}} = \frac{4 \times 10^5 \text{ N/m}^2 \times A}{0.6 \text{ m}^3 / A}$$

$$\text{Work against spring} = \frac{1}{2} \cdot K \cdot x^2 = \frac{1}{2} \times \frac{4 \times 10^5 \text{ N/m}^2 \times A}{0.6 \text{ m}^3 / A} \times \left( \frac{0.6 \text{ m}^3}{A} \right)^2 = 1.2 \times 10^2 \text{ kJ}$$

### EXAMPLE 1.7

A cylinder fitted with a piston has an initial volume of  $0.1 \text{ m}^3$  and contains nitrogen at  $150 \text{ kPa}$ ,  $25^\circ\text{C}$ . The piston moves compressing the nitrogen until the pressure becomes  $1 \text{ MPa}$  and temperature becomes  $150^\circ\text{C}$ . During the compression process heat is transferred from nitrogen and work done on nitrogen is  $20 \text{ kJ}$ . Determine the amount of this heat transfer. Assume  $R = 2,968 \text{ J/kg K}$  and  $C_v = 743 \text{ J/kg}$ .

**SOLUTION**

Change in internal energy of nitrogen =  $m \cdot C_v \cdot dT$

$$m = \frac{P_1 V_1}{RT_1} = \frac{150 \times 10^3 \text{ N/m}^2 \times 0.1 \text{ m}^3}{2,968 \text{ J/KgK} \times 298 \text{ K}} = 0.0169 \text{ kg}$$

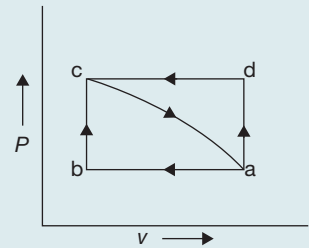
$$\Delta u = 0.0169 \text{ kg} \times 743 \text{ J/kg} \times 125 \text{ K} = 1.569 \text{ kJ}$$

$$W = -20 \text{ kJ}; \quad Q = \Delta u + W = 1.569 \text{ kJ} - 20 \text{ kJ} = \mathbf{-18.43 \text{ kJ}}$$

**EXAMPLE 1.8**

Figure shows two reversible processes  $a - b - c - a$  and  $a - d - c - a$ . The change in internal energy from  $c$  to  $a$  is  $50 \text{ kJ}$  and work done by the system during the process  $a - d$  is  $30 \text{ kJ}$ . Find:

- (i) Heat interaction during the process  $a - b - c$ .
- (ii) Heat interaction during the process  $a - d - c$  if work done during  $d - c$  is  $10 \text{ kJ}$ .
- (iii) Heat interaction during the process  $c - a$  if work done on the system during the process  $c - a$  is  $20 \text{ kJ}$ .

**FIGURE 1.6**

P-V Diagram

**SOLUTION**

$$(i) \quad W_{a-b} = 30 \text{ kJ}$$

$$\Delta u = u_a - u_c = 50 \text{ kJ} \quad \text{or} \quad u_c - u_a = -50 \text{ kJ}$$

$$W_{b-c} = 0; \quad W_{a-b-c} = 30 \text{ kJ}$$

$$Q_{a-b-c} = u_c - u_a + W_{a-b-c} = -50 \text{ kJ} + 30 \text{ kJ} = \mathbf{-20 \text{ kJ}} \text{ (Heat liberated)}$$

$$(ii) \quad W_{d-c} = 10 \text{ kJ}; \quad W_{a-d} = 0; \quad W_{a-d-c} = 10 \text{ kJ}$$

$$u_c - u_a = -50 \text{ kJ}; \quad Q_{a-d-c} = u_c - u_a + W_{a-d-c} = -50 \text{ kJ} + 10 \text{ kJ} = \mathbf{-40 \text{ kJ}}$$

**(Heat liberated)**

$$(iii) \quad W_{c-a} = -20 \text{ kJ}$$

$$\Delta u = u_a - u_c = 50 \text{ kJ}; \quad Q_{c-a} = u_a - u_c + W_{c-a} = 50 \text{ kJ} - 20 \text{ kJ} = \mathbf{30 \text{ kJ}}$$

**(Heat absorbed)**

**EXAMPLE 1.9**

A hydraulic brake is used to test an engine at a speed of 1200 *rpm*. The measured torque of the engine is 15000 *Nm* and the water flow rate is 0.8 cubic meter per second, its inlet temperature is 15°C. Calculate the water temperature at the exit, assuming that the whole of the engine power is ultimately transformed into heat which is absorbed by the water flow.

**SOLUTION**

$$\text{Power } (P) = \text{Torque } (T) \times \text{Angular velocity } (\omega) = 15000 \text{ Nm} \times \frac{2\pi \times 1200 \text{ rpm}}{60 \text{ sec}} = 1,570 \text{ kW}$$

Power = Heat transfer rate

$$1,570 = \dot{m} s \Delta t = 0.8 \text{ m}^3/\text{sec} \times 1000 \text{ kg/m}^3 \times 4.2 \text{ kJ/kg.K} (t_2 - 15^\circ\text{C})$$

$$t_2 = \mathbf{15.46^\circ\text{C}}$$

**EXAMPLE 1.10**

In a cyclic process, the amount of heat transfers are given as 15 *kJ*, -27 *kJ*, -4 *kJ* and 32 *kJ*. Calculate the net work done in the cyclic process.

**SOLUTION**

$$W = Q_1 + Q_2 + Q_3 + Q_4 = 15 \text{ kJ} - 27 \text{ kJ} - 4 \text{ kJ} + 32 \text{ kJ} = \mathbf{16 \text{ kJ}}$$

**EXAMPLE 1.11**

In a cyclic process, an engine engages into two work interactions—18 *kJ* to the fluid and 48 *kJ* from the fluid, and two heat interactions out of three are given as—80 *kJ* to the fluid and 44 *kJ* from the fluid. Find the magnitude and direction of the third heat transfer.

**SOLUTION**

$$W_1 + W_2 = Q_1 + Q_2 + Q_3$$

$$Q_3 = W_1 + W_2 - Q_1 - Q_2 = -18 \text{ kJ} + 48 \text{ kJ} - 80 \text{ kJ} + 44 \text{ kJ} = \mathbf{-6 \text{ kJ (Heat rejection)}}$$

**EXAMPLE 1.12**

During a certain period of analysis, a refrigerator consuming the energy at the rate of 1.5 *kJ* per hour loses internal energy of its system by 4500 *kJ*. Calculate the heat transfer for the system for that period.

**SOLUTION**

$$W = -1.5 \text{ kWh}, \Delta u = -4,500 \text{ kJ}$$

$$Q = \Delta u + W = -4,500 \text{ kJ} - 1.5 \text{ kJ} \times 3,600 \text{ sec} = -9,900 \text{ kJ} = \mathbf{-9.9 \text{ MJ (Heat rejection)}}$$

**EXAMPLE 1.13**

2 kg of water having a constant specific heat 4.18 kJ/kgK is stirred in a well-insulated jar results in rise of temperature by 18°C. Find the  $\Delta u$  and  $W$  of the process.

**SOLUTION**

$$\Delta u = mC_v \Delta t = 2 \times 4.18 \text{ kJ/kg.K} \times 18^\circ \text{C} = \mathbf{150.48 \text{ kJ}};$$

$$\Delta Q = 0 = \Delta u + W$$

$$W = \mathbf{-150.48 \text{ kJ}}$$

**EXAMPLE 1.14**

1 kg of air at 9 bar pressure and 80°C temperature undergoes a non-flow work polytropic process. The law of expansion is  $PV^{1.1} = C$ . The pressure falls to 1.4 bar during process. Calculate: (i) Final temperature, (ii) Work done, (iii) Change in internal energy, and (iv) Heat exchange. Take  $R = 287 \text{ J/kg}$  and  $\gamma = 1.4$  for air.

**SOLUTION**

$$m = 1 \text{ kg}; P_1 = 9 \text{ bar}; T_1 = 273 + 80^\circ \text{C} = 353 \text{ K}; P_2 = 1.4 \text{ bar};$$

$$n = 1.1; \gamma = 1.4; R = 0.287 \text{ kJ/kgK}$$

$$T_2 = \left( \frac{P_2}{P_1} \right)^{\frac{n-1}{n}} T_1 = \left( \frac{9(10^5) \text{ Pa}}{1.4(10^5) \text{ Pa}} \right)^{\frac{1.1-1}{1.1}} \times 353 \text{ K} = \mathbf{298.06 \text{ K}}$$

$$\Delta u = mC_v (T_2 - T_1) = 1 \text{ kg} \times 0.718 \text{ kJ/kg.K} \times (298.06 \text{ K} - 353 \text{ K}) = \mathbf{-39.443 \text{ kJ}}$$

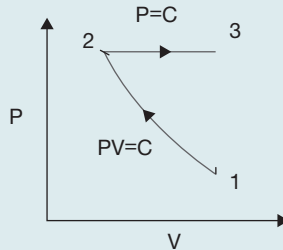
$$W = \frac{P_1 V_1 - P_2 V_2}{n-1} = \frac{mR(T_1 - T_2)}{n-1} = \frac{1 \text{ kg} \times 0.287(10^3) \text{ J/kgK} \times (353 \text{ K} - 298.06 \text{ K})}{1.1-1}$$

$$= \mathbf{157.85 \text{ kJ}}$$

$$Q = \Delta u + W = -39.443 \text{ kJ} + 157.85 \text{ kJ} = \mathbf{118.407 \text{ kJ}}$$

**EXAMPLE 1.15**

0.2 kg of air is compressed by following the process of isothermal from 40 kPa 30°C to 0.2 MPa and is expanded at constant pressure to the original volume as shown in Figure 1.7. Compute the net work to be obtained and also the heat transfer.


**FIGURE 1.7**

Isothermal Compression and Constant Pressure Expansion

**SOLUTION**

$$P_1 = 40 \text{ kPa}; T_1 = 30^\circ \text{C} = 273 + 30^\circ \text{C} = 303 \text{K}; m = 0.2 \text{ kg}; P_2 = 0.2 \text{ MPa}$$

Isothermal Process: 1–2

$$P_1 V_1 = mRT_1$$

$$V_1 = \frac{mRT_1}{P_1} = \frac{0.2 \text{ kg} \times 0.287 (10^3) \text{ J/kgK} \times 303 \text{ K}}{40 (10^3) \text{ Pa}} = 0.434 \text{ m}^3$$

$$P_1 V_1 = P_2 V_2 = \text{Constant}$$

$$V_2 = \frac{P_1 V_1}{P_2} = \frac{40 (10^3) \text{ Pa} \times 0.434 \text{ m}^3}{0.2 (10^6) \text{ Pa}} = 0.086 \text{ m}^3$$

$$W_{1-2} = P_1 V_1 \ln \left( \frac{P_1}{P_2} \right) = 40 (10^3) \text{ Pa} \times 0.434 \text{ m}^3 \times \ln \left( \frac{40 (10^3) \text{ Pa}}{0.2 (10^6) \text{ Pa}} \right) = -27.939 \text{ kJ}$$

$$\Delta u = mC_v (T_2 - T_1) = 0$$

$$Q_{1-2} = W_{1-2} = -27.939 \text{ kJ}$$

Constant Pressure Process: 2–3

$$\frac{V_2}{T_2} = \frac{V_3}{T_3}$$

$$T_3 = \frac{V_3}{V_2} T_2 = \frac{0.434 \text{ m}^3}{0.086 \text{ m}^3} \times 303 \text{ K} = 1512.195 \text{ K}$$

$$W_{2-3} = P_2 (V_3 - V_2) = 0.2 (10^6) \text{ Pa} \times (0.434 \text{ m}^3 - 0.086 \text{ m}^3) = 69.6 \text{ kJ}$$

$$\begin{aligned} Q_{2-3} &= mC_v (T_3 - T_2) + W_{2-3} \\ &= 0.2 \text{ kg} \times 0.718 (10^3) \text{ J/kgK} \times (1512.195 \text{ K} - 303 \text{ K}) + 69.6 (10^3) \text{ J} \\ &= 243.24 \text{ kJ} \end{aligned}$$



$$\begin{aligned}\text{Net work, } W &= W_{1-2} + \dot{W}_{2-3} = -27.939 \text{ kJ} + 69.6 \text{ kJ} = \mathbf{41.661 \text{ kJ}} \\ \text{Total heat transfer, } Q &= Q_{1-2} + Q_{2-3} = -27.939 \text{ kJ} + 243.24 \text{ kJ} = \mathbf{215.301 \text{ kJ}}\end{aligned}$$

**EXAMPLE 1.16**

0.2 m<sup>3</sup> of air at 4 bar and 150°C expands isentropically to a pressure of 1 bar. The gas is then heated at constant pressure till it attains its initial temperature. Determine the change of internal energy and work done.

**SOLUTION**

$$V_1 = 0.2 \text{ m}^3; P_1 = 4 \text{ bar}; T_1 = 150^\circ\text{C} = 273 + 150 = 423 \text{ K}; P_2 = 1 \text{ bar.}$$

$$m = \frac{P_1 V_1}{RT_1} = \frac{4(10^5) \text{ Pa} \times 0.2 \text{ m}^3}{0.287(10^3) \text{ J/kgK} \times 423 \text{ K}} = 0.659 \text{ kg}$$

$$\frac{T_2}{T_1} = \left(\frac{P_2}{P_1}\right)^{\frac{\gamma-1}{\gamma}}; T_2 = \left(\frac{P_2}{P_1}\right)^{\frac{\gamma-1}{\gamma}} T_1 = \left(\frac{1 \text{ bar}}{4 \text{ bar}}\right)^{\frac{1.4-1}{1.4}} \times 423 \text{ K} = 284.657 \text{ K}$$

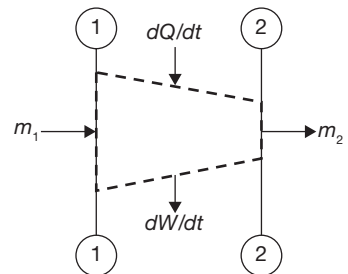
$$Q = \Delta u + W = 0 \text{ (Since heat transfer in isentropic process is zero)}$$

$$\begin{aligned}W &= -\Delta u = -mC_v(T_2 - T_1) = -0.659 \text{ kg} \times 0.718 \text{ kJ/kgK} \times (284.657 \text{ K} - 423 \text{ K}) \\ &= \mathbf{65.458 \text{ kJ}}\end{aligned}$$

### 1.4.6 Application of First Law of Thermodynamics in Steady Flow Process and Variable Flow Process

**Steady Flow Process:** In a steady flow process, thermodynamic properties at any section remain constant with respect to time; it can vary only with respect to space. A schematic diagram of steady flow process is shown in Figure 1.8.

Let  $A_1, A_2$  - Cross-sectional area at section 1 and 2, m<sup>2</sup>  
 $M_1, m_2$  - Mass flow rate at section 1 and 2, kg/sec  
 $P_1, P_2$  - Absolute pressure at section 1 and 2, N/m<sup>2</sup>  
 $V_1, V_2$  - Specific volume at section 1 and 2, m<sup>3</sup>/kg  
 $u_1, u_2$  - Specific internal energy at section 1 and 2, J/kg  
 $v_1, v_2$  - Velocity at section 1 and 2, m/sec  
 $Z_1, Z_2$  - Elevation of the section 1 and 2 above the arbitrary datum, m

**FIGURE 1.8**

Schematic Diagram of Steady Flow Process

$dQ/dt$  - Net rate of heat flows through control surface, J/sec

$dW/dt$  - Net rate of work transfer through control surface, J/sec

$t$  - Time, sec

From continuity equation:  $m_1 = m_2$ ;  $\frac{A_1 v_1}{V_1} = \frac{A_2 v_2}{V_2}$

Energy balance equation:

$$m_1 \left( \frac{v_1^2}{2} + Z_1 g + u_1 \right) + m_1 P_1 V_1 + \frac{dQ}{dt} = m_2 \left( \frac{v_2^2}{2} + Z_2 g + u_2 \right) + m_2 P_2 V_2 + \frac{dW}{dt};$$

$$m_1 \left( h_1 + \frac{v_1^2}{2} + Z_1 g \right) + \frac{dQ}{dt} = m_2 \left( h_2 + \frac{v_2^2}{2} + Z_2 g \right) + \frac{dW}{dt}; \text{ since } h = u + PV$$

This is known as steady flow energy equation (SFEE) for a single stream.

**Variable Flow Process:** In some flow process, mass flow rate is not steady but varies with respect to time. In such a case, the difference in energy flow is stored in system as  $\Delta E_v$ .

$$\Delta m = \frac{dm}{dt} = m_1 - m_2$$

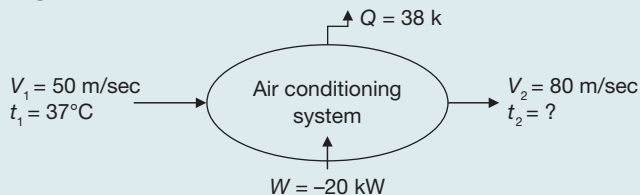
The rate of energy increase = Rate of energy inflow – Rate of energy outflow

$$\frac{dE_v}{dt} = \frac{dm_1}{dt} \left( h_1 + \frac{v_1^2}{2} + Z_1 g \right) + \frac{dQ}{dt} - \frac{dm_2}{dt} \left( h_2 + \frac{v_2^2}{2} + Z_2 g \right) + \frac{dW}{dt}$$

$$\Delta E_v = Q - W + \int \left( h_1 + \frac{v_1^2}{2} + Z_1 g \right) dm_1 - \int \left( h_2 + \frac{v_2^2}{2} + Z_2 g \right) dm_2$$

### EXAMPLE 1.17

An air conditioning system, as shown in Figure 1.9, handling 1 kg/sec of air at 37°C and consumes a power of 20 kW and rejects heat of 38 kW. The inlet and outlet velocities of air are 50 and 80 m/sec, respectively. Find the exit air temperature, assuming adiabatic conditions. Take  $C_p$  of air as 1.005 kJ/kg.



**FIGURE 1.9**

Air Conditioning System

**SOLUTION**

$$m \left( h_1 + \frac{V_1^2}{2 \times 1000} \right) + \frac{dW}{dt} = m \left( h_2 + \frac{V_2^2}{2 \times 1000} \right) + \frac{dQ}{dt}$$

$$C_p(t_1 - t_2) + \frac{V_1^2 - V_2^2}{2000} = -20 \text{ kW} + 38 \text{ kW}$$

$$1.005 \text{ kJ/kgK}(37^\circ\text{C} - t_2) = 18 - \frac{50^2 - 80^2}{2000}; t_2 = 17.149^\circ\text{C}$$

**EXAMPLE 1.18**

In a cooling tower of a power plant (Figure 1.10), air enters at a height of 1 m above the ground and leaves at 8 m. The inlet and outlet velocities are 18 and 27 m/sec, respectively. Water enters at a height of 10 m and leaves at a height of 0.5 m. The velocity of water at entry and exit are 5 and 1.5 m/sec, respectively. Water temperatures are 85 and 420°C at inlet and exit, respectively. Air temperatures are 27 and 700°C at entry and exit, respectively. The cooling tower is fully insulated and a fan of 2.5 kW drives air through the cooler. Find the air per sec required for 1 kg/sec of water flow. The values of  $C_p$  of air and water are 1.005 and 4.18 kJ/kgK, respectively.

**SOLUTION**

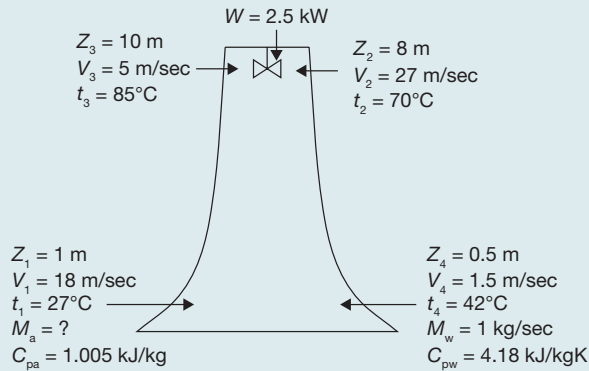
$$\dot{m}_a \left( h_1 + \frac{V_1^2}{2} + Z_1 g \right) + \dot{m}_w \left( h_3 + \frac{V_3^2}{2} + Z_3 g \right) = \dot{m}_a \left( h_2 + \frac{V_2^2}{2} + Z_2 g \right) + \dot{m}_w \left( h_4 + \frac{V_4^2}{2} + Z_4 g \right) + \frac{dW}{dt}$$

$$\dot{m}_a \left[ (h_1 - h_2) + \frac{V_1^2 - V_2^2}{2} + (Z_1 - Z_2)g \right] = \dot{m}_w \left[ (h_4 - h_3) + \frac{V_4^2 - V_3^2}{2} + (Z_4 - Z_3)g \right] + \frac{dW}{dt}$$

$$\dot{m}_a \left\{ 1.005 \text{ kJ/kg.K}(27 \text{ kJ/kg} - 70 \text{ kJ/kg}) + \frac{(18 \text{ m/sec})^2 - (27 \text{ m/sec})^2}{2000} + \frac{(1 \text{ m} - 8 \text{ m}) \times 9.81 \text{ m/sec}^2}{1000} \right\}$$

$$= 1 \left\{ 4.18 \text{ kJ/kg.K}(42 \text{ kJ/kg} - 85 \text{ kJ/kg}) + \frac{(1.5 \text{ m/sec})^2 - (5 \text{ m/sec})^2}{2000} + \frac{(0.5 \text{ m} - 10 \text{ m}) \times 9.81 \text{ m/sec}^2}{1000} \right\} + (-2.5 \text{ kJ})$$

$$\dot{m}_a = 4.193 \text{ kg/sec}$$


**FIGURE 1.10**

Cooling Tower

**EXAMPLE 1.19**

In a centrifugal air compressor, initial pressure, and specific volume are 1 bar and  $1 \text{ m}^3/\text{kg}$ , respectively and final pressure is 5 bar and volume is  $0.1 \text{ m}^3/\text{kg}$ , respectively. The air flow rate is  $30 \text{ kg/min}$ . The heat liberated to atmosphere from compressor is  $60 \text{ kW}$  and inlet velocity of air =  $10 \text{ m/sec}$ , outlet velocity of air =  $5 \text{ m/sec}$ . Find:

- (i) Compressor work.
- (ii) Ratio of inlet and outlet area, if internal energy at the outlet is  $100 \text{ kJ}$  more than that of inlet. Solve the problem using SFEE.

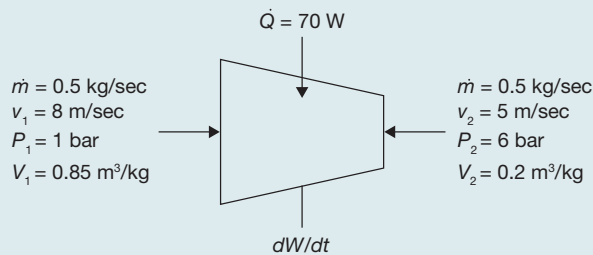
**SOLUTION**

$$\begin{aligned}
 \text{(i)} \quad m \left( P_1 V_1 + u_1 + \frac{v_1^2}{2} + Z_1 g \right) + \frac{dQ}{dt} &= m \left( P_2 V_2 + u_2 + \frac{v_2^2}{2} + Z_2 g \right) + \frac{dW}{dt} \\
 \frac{dW}{dt} &= m \left[ (P_1 V_1 - P_2 V_2) + (u_1 - u_2) + \frac{v_1^2 - v_2^2}{2} + (Z_1 - Z_2) g \right] + \frac{dQ}{dt} \\
 &= \frac{30 \text{ kg/min}}{60 \text{ sec}} \left[ (1 \times 10^2 \text{ kPa} \times 1 \text{ m}^3 - 5 \times 10^2 \text{ kPa} \times 0.1 \text{ m}^3) \right. \\
 &\quad \left. + 100 \text{ kJ} + \frac{(10 \text{ m/sec})^2 - (5 \text{ m/sec})^2}{2} + 0 \right] - 60 \text{ kJ/sec} \\
 &= \mathbf{34.25 \text{ kW}}
 \end{aligned}$$

$$\text{(ii)} \quad m = \frac{A_1 v_1}{V_1} = \frac{A_2 v_2}{V_2} \Rightarrow \frac{A_1}{A_2} = \frac{5 \text{ m/sec}}{10 \text{ m/sec}} \times \frac{1 \text{ m}^3}{0.1 \text{ m}^3} = \mathbf{5}$$

**EXAMPLE 1.20**

Air enters in a compressor at the rate of 0.5 kg/sec, at 8 m/sec with a pressure of 1 bar and a specific volume of 0.85 m<sup>3</sup>/kg, and leaving at 5 m/sec with a pressure of 6 bar and a specific volume of 0.2 cubic meter per kg (Figure 1.11). The internal energy of the air leaving is 80 kJ/kg greater than that of the air entering. Cooling water in a jacket surrounding the cylinder absorbs heat from the air at the rate of 70 W. Calculate the power required to drive the compressor and the inlet, and outlet cross-sectional areas.

**FIGURE 1.11**

Compressor

**SOLUTION**

$$\begin{aligned} \dot{m} \left( u_1 + P_1 V_1 + \frac{v_1^2}{2} \right) + \frac{dQ}{dt} &= \dot{m} \left( u_2 + P_2 V_2 + \frac{v_2^2}{2} \right) + \frac{dW}{dt} \\ \frac{dW}{dt} &= \dot{m} \left[ (u_1 - u_2) + (P_1 V_1 - P_2 V_2) + \left( \frac{v_1^2 - v_2^2}{2} \right) \right] + \frac{dQ}{dt} \\ &= 0.5 \text{ kg/sec} \left\{ -80 \text{ kJ/kg} + (1 \times 10^2 \text{ kPa} \times 0.85 \text{ m}^3 \right. \\ &\quad \left. - 6 \times 10^2 \text{ kPa} \times 0.2 \text{ m}^3) + \left( \frac{(8 \text{ m/sec})^2 - (5 \text{ m/sec})^2}{2000} \right) \right\} \\ &\quad + .07 \text{ kJ/sec} = \mathbf{-58.82 \text{ kW}} \\ \dot{m} &= \frac{A_1 v_1}{V_1} = \frac{A_2 v_2}{V_2} \Rightarrow A_1 = \frac{0.5 \text{ kg/sec} \times 0.85 \text{ m}^3}{8 \text{ m/sec}} = \mathbf{0.531 \text{ m}^2} \\ A_2 &= \frac{0.5 \text{ kg/sec} \times 0.2 \text{ m}^3}{5 \text{ m/sec}} = \mathbf{0.02 \text{ m}^2} \end{aligned}$$

**1.4.7 Limitations of First Law of Thermodynamics**

First law of thermodynamics does not tell about the following:

- ▶ How much of the given quantity of heat is changed into work?
- ▶ In which direction does the changing take place (heat to work or work to heat)?
- ▶ Under which condition will the changing take place?

## 1.5 ► THE SECOND LAW OF THERMODYNAMICS

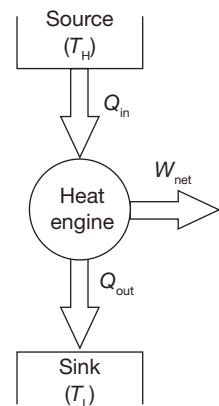
Second law of thermodynamics overcomes the limitations of the first law of thermodynamics. First law of thermodynamics doesn't tell how much of the heat is changed into work. Second law of thermodynamics shows that the total heat supplied to a system cannot be transferred solely into the work using single reservoir, i.e., some part of heat must be rejected to sink. It also shows the direction of the energy transfer, i.e., heat cannot be transferred from a lower temperature reservoir to higher temperature reservoir without the external work done on the system.

### 1.5.1 Kelvin-Planck Statement

The Kelvin-Planck statement of the second law of thermodynamics refers to a thermal reservoir. A thermal reservoir is a system of infinite heat capacity that remains at a constant temperature even though energy is added or removed as heat transfer. A reservoir is an idealization, of course, but such a system can be approximated in a number of ways—by the Earth's atmosphere, large bodies of water (oceans), and so on.

The Kelvin-Planck statement of the second law can be given as—*It is impossible for any system to operate in a thermodynamic cycle and deliver a net amount of energy by work to its surroundings while receiving energy by heat transfer from a single thermal reservoir.*

In Figure 1.12, it is shown that there are two reservoirs from which heat is interacted to do a work  $W_{\text{net}}$ . Heat,  $Q_{\text{H}}$  is taken from the higher temperature reservoir and work is done and rest amount of heat is rejected to lower temperature reservoir. Thus, the total conversion of heat to work is impossible, there will be always rejection of some part of the heat supplied the heat engine.



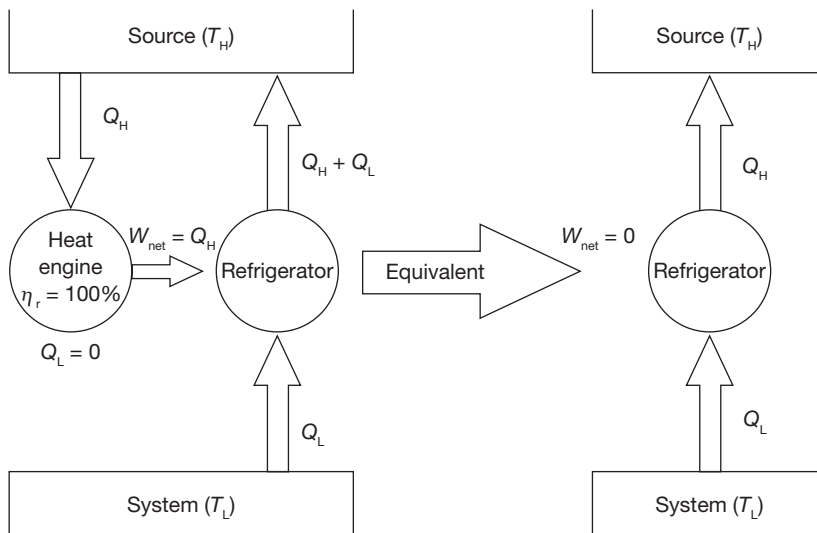
**FIGURE 1.12**

Heat Engine

### 1.5.2 Clausius Statement

*It is impossible to construct a device that operates in a cycle and produces no effect other than the transfer of heat from a lower-temperature body to higher-temperature body.* In other words, a refrigerator cannot be operated without external work supplied to the refrigeration system.

Heat flows from high-temperature to the low-temperature reservoir. To reverse the direction of flow of heat, there is a requirement of some additional work on the system. On this principle refrigerator and heat pump are working. The violation of Clausius statement is shown in Figure 1.13.



**FIGURE 1.13**

The Violation of the Kelvin–Planck Statement Leads to Violation of Clausius

The two statements of the second law are equivalent. In other words, any device violates the Kelvin–Planck statement also violates the Clausius statement and vice versa. Any device that violates the first law of thermodynamics (by creating energy) is called a perpetual-motion machine of the first kind (PMM1), and the device that violates the second law is called a perpetual-motion machine of the second kind (PMM2).

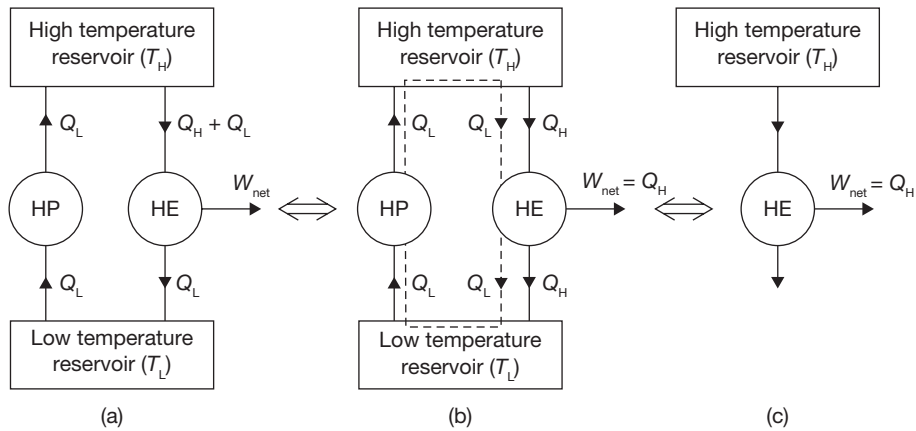
### 1.5.3 Equivalence of Kelvin–Planck and Clausius Statement

#### *Violation of Kelvin–Planck Statement by Violating Clausius Statement*

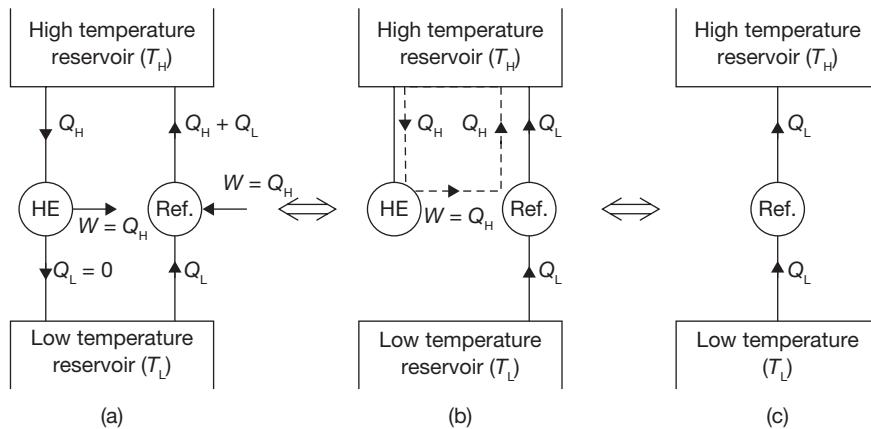
From Figure 1.14 (a) let us assume that a heat pump receives heat  $Q_L$  from the low-temperature reservoir at  $T_L$  and supplies it to high-temperature sink at  $T_H$  without any external work, thus violating the Clausius statement. A larger quantity of heat ( $Q_H + Q_L$ ) is supplied to heat engine (by high-temperature source at  $T_H$ ).

Which produces net work output,  $W_{\text{net}}$ , equal to  $Q_H$  and rejects an amount of heat,  $Q_L$ , to the low-temperature reservoir. The composite of two devices is shown in Figure 1.14 (b). It shows that the heat pump helps the heat  $Q_L$  to flow from the low-temperature reservoir to high-temperature reservoir, whereas, the heat engine supplies back heat  $Q_L$  from high-temperature reservoir to low-temperature thermal energy reservoir. The equivalent system receives heat  $Q_H$  from the high-temperature reservoir and produces an equivalent amount of work, as shown is Figure 1.14 (c).

From Figure 1.14 (c), it can be observed that a heat engine receives heat from a single reservoir and produces an equivalent amount of work. It is, therefore, a perpetual motion


**FIGURE 1.14**

Violation of Kelvin–Planck Statement by Violating Clausius Statement


**FIGURE 1.15**

Violation of Clausius Statement by Violating Kelvin–Planck's Statement

machine II (PMM-2), which violates the Kelvin-Planck's statement for the second law of thermodynamics. Thus, a violation of Clausius statement leads to violation of Kelvin Plank's statement, and we can say, the two statements are equivalent.

### *Violation of Clausius Statement by Violating Kelvin–Planck's Statement*

From Figure 1.15 (a), let us assume that a heat engine receives heat  $Q_H$  from a high-temperature reservoir and convert it into work rejecting no heat to sink, thus violating Kelvin Plank's statement. Refrigerator's receives heat  $Q_L$  from the low-temperature reservoir and supplies an amount  $(Q_H + Q_L)$  to the high-temperature reservoir when  $W = Q_H$  work is supplied to it. Thus, it operates



to conform the Clausius statement. But, from Figure 1.15 (b), it can be observed that heat  $Q_H$  follows a loop though HE and HP and perform no function. From Figure 1.15 (c), it is obvious the heat is being transferred from a low-temperature thermal energy reservoir to the high-temperature thermal energy reservoir, without any external work. It is therefore a violation of Clausius statement. Thus, a violation of Kelvin-Plank's and we can say, the two statements are equivalent.

## 1.6 ► REVERSIBLE AND IRREVERSIBLE PROCESSES

In reversible process things happen very slowly, without any resisting force, without any space limitation, everything happens in a highly organized way (it is not physically possible; it is an idealization). Internally reversible process—a system undergoes through a series of equilibrium states, and when the process is reversed, the system passes through exactly the same equilibrium states while returning to its initial state. Externally reversible process—heat transfer between a reservoir and a system is an externally reversible process if the surface of contact between the system and reservoir is at the same temperature.

A process is said to be reversible if it is possible for its effects to be eradicated in the sense that there is some way by which both the system and its surroundings can be exactly restored to their respective initial states. A process is irreversible if there is no way to undo it. Thus, there are no means by which the system and its surroundings can be exactly restored to their respective initial states. A system that has undergone an irreversible process is not necessarily precluded from being restored to its initial state. There are many effects whose presence during a process renders it irreversible. These include the following—heat transfer through a finite temperature difference; unrestrained expansion of a gas or liquid to a lower pressure; spontaneous chemical reaction; mixing of matter at different compositions or states; friction; electric current flow through a resistance; magnetization or polarization with hysteresis; and inelastic deformation, etc. Irreversibilities can be divided into two classes—internal and external. Internal irreversibilities are those that occur within the system, while external irreversibilities are those that occur within the surroundings, normally the immediate surroundings. For a gas as the system, the work of expansion arises from the force exerted by the system to move the boundary against the resistance offered by the surroundings:

$$W = \int FdX = \int PA dX = \int PdV$$

where the force is the product of the moving area and the pressure exerted by the system and  $Adx$  is the change in total volume of the system.

## 1.7 ► THE CARNOT CYCLE

The efficiency of a heat-engine cycle greatly depends on how the individual processes are executed. The net work can be maximized by using reversible processes. The best known reversible cycle is the Carnot cycle.

Note that the reversible cycles cannot be achieved in practice because of irreversibilities associated with real processes. But, the reversible cycles provide upper limits on the performance of real cycles.

Consider a gas in a cylinder-piston (closed system). The Carnot cycle has four processes as (Figure 1.16):

**1-2 Reversible isothermal expansion:** The gas expands slowly; heat is added reversibly at constant temperature ( $T_H$ ) to the system. Work is done on the surrounding.

**2-3 Reversible adiabatic expansion:** The cylinder-piston is now insulated (adiabatic) and gas continues to expand reversibly (slowly). So, the gas is doing work on the surroundings, and as a result of expansion, the gas temperature reduces from  $T_H$  to  $T_L$ .

**3-4 Reversible isothermal compression:** The gas is allowed to exchange heat with a sink at temperature  $T_L$  as the gas is being slowly compressed. So, the surrounding is doing work (reversibly) on the system and heat is transferred from the system to the surroundings (reversibly) such that the gas temperature remains constant at  $T_L$ .

**4-1 Reversible adiabatic compression:** The gas temperature is increasing from  $T_L$  to  $T_H$  as a result of compression. Carnot cycle is the most efficient cycle operating between two specified temperature limits.

The efficiencies of all reversible heat engines operating between the two same reservoirs are the same. The thermal efficiency of a heat engine (reversible or irreversible) is:

$$\eta_{th} = 1 - \frac{Q_L}{Q_H} = 1 - \frac{T_L}{T_H}$$

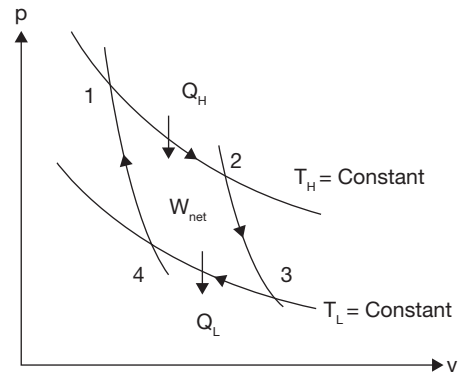
The efficiency of an irreversible (real) cycle is always less than the efficiency of the Carnot cycle operating between the same two reservoirs.

$$\eta_{th} \begin{cases} < \eta_{th,rev} & \text{irreversible heat engine} \\ = \eta_{th,rev} & \text{reversible heat engine} \\ > \eta_{th,rev} & \text{impossible heat engine} \end{cases}$$

### Carnot Corollaries

The two corollaries of the second law known as Carnot corollaries:

- (1) The thermal efficiency of an irreversible power cycle is always less than the thermal efficiency of a reversible power cycle when each operates between the same two thermal reservoirs.



**FIGURE 1.16**

P-V Diagram of Carnot Cycle

- (2) All reversible power cycles operating between the same two thermal reservoirs have the same thermal efficiency.

## 1.8 ► THE CLAUSIUS INEQUALITY

The Clausius inequality is given by the equation

$$\oint \left( \frac{\delta Q}{T} \right)_b \leq 0$$

where  $\delta Q$  represents the heat transfer at a part of the system boundary during a portion of the cycle, and  $T$  is the absolute temperature at that part of the boundary. The symbol  $\delta$  is used to distinguish the differentials of nonproperties, such as heat and work, from the differentials of properties, written with the symbol  $d$ . The subscript  $b$  indicates that the integrand is evaluated at the boundary of the system executing the cycle. The symbol  $\oint$  indicates that the integral is to be performed over all parts of the boundary and over the entire cycle. The Clausius inequality can be demonstrated using the Kelvin-Planck statement of the second law, and the significance of the inequality is the same—the equality applies when there are no internal irreversibilities as the system executes the cycle, and the inequality applies when internal irreversibilities are present.

The Clausius inequality can be expressed alternatively as:

$$\oint \left( \frac{\delta Q}{T} \right)_b = -S_{gen}$$

Where  $S_{gen}$  can be viewed as representing the strength of the inequality. The value of  $S_{gen}$  is positive when internal irreversibilities are there and zero when no internal irreversibilities are there;  $S_{gen}$  cannot be negative. Thus,  $S_{gen}$  is a measure of the irreversibilities within the system executing the cycle.

## 1.9 ► ENTROPY AND ENTROPY GENERATION

### 1.9.1 Entropy

Defining entropy in an exact word or line is impossible. It can be viewed as a measure of molecular disorder or molecular randomness. As a system becomes more disordered, the positions of the molecules become less predictable and the entropy increases. Thus, the entropy of a substance is the lowest in the solid phase and highest in the gas phase. Heat is, in essence, a form of disorganized energy, and some disorganization (entropy) will flow with heat. Work instead is an organized form of energy, and is free of disorder or randomness and

thus free of entropy. There is no entropy transfer associated with energy transfer as work. Unlike energy, entropy is a non conserved property.

According to Clausius inequality,  $\oint \frac{\delta Q}{T} \leq 0$  is a cyclic integral of differential heat flow  $\delta Q$  at absolute temperature  $T$ . For a process change in entropy is defined by

$$\Delta S = S_2 - S_1 \geq \int_1^2 \left( \frac{\delta Q}{T} \right)_{\text{int rev}}$$

Entropy always increases. For all process  $\Delta S = S_2 - S_1 \geq \int_1^2 \frac{\delta Q}{T}$

To make it equality, add entropy generation term

$$\Delta S = S_2 - S_1 = \int_1^2 \frac{\delta Q}{T} + S_{\text{Gen}}$$

### 1.9.2 Entropy Generation

- ▶  $S_{\text{GEN}} > 0$  for an irreversible (real) process
- ▶  $S_{\text{GEN}} = 0$  for a reversible (ideal) process
- ▶  $S_{\text{GEN}} < 0$  for an impossible process

$S_{\text{GEN}}$  includes the change in  $S$  of the substance in the system and the heat transfer,  $Q$ , to/from the surroundings. Entropy always increases. It cannot be conserved (does not balance or return to zero, i.e., there is no law of conservation of entropy). The amount of entropy increase gives a measure of the magnitude of irreversibility in a process.

### 1.9.3 Entropy Balance

- ▶  $\Delta S_{\text{system}} = S_{\text{transfer}} + S_{\text{GEN}}$
- ▶  $\Delta S_{\text{system}} = S_{\text{final}} - S_{\text{initial}}$
- ▶  $\Delta S_{\text{system}} = m(s_{\text{final}} - s_{\text{initial}})$  using specific entropy

$S_{\text{transfer}}$  comes from heat transfer,  $Q$ , or from mass flow  $\dot{m}$ ,

If heat transfer occurs,  $S_{\text{transfer}} = Q/T$

If mass flow occurs,

- ▶  $S_{\text{transfer}} = m \cdot s$  (for mass entering the system)
- ▶  $S_{\text{transfer}} = -m \cdot s$  (for mass leaving the system)

- ▶  $S_{\text{GEN}} = 0$  for an internally reversible process
- ▶  $S_{\text{GEN}} > 0$  for a real, irreversible process

For a closed system (no mass flow):

$$\Delta S = S_2 - S_1 = \sum \frac{Q_k}{T_k} + S_{\text{GEN}}$$

$$\frac{dS}{dt} = \sum \frac{\dot{Q}_k}{T_k} + \dot{S}_{\text{Gen}}$$

in terms of rate:

For an Adiabatic System (when  $dQ = 0$ ):

$$S_2 - S_1 = S_{\text{GEN}}$$

For an open system steady flow process:

$$\dot{S}_{\text{GEN}} = \sum \dot{m}_e s_e - \sum \dot{m}_i s_i - \sum \frac{\dot{Q}_k}{T}$$

### 1.9.4 Evaluation of Entropy Change

From equation:

(i)  $Tds = du + pdv$

or,  $ds = \frac{du}{T} + \frac{p}{T}dv = \frac{c_v dT}{T} + \frac{R}{V}dV$

or,  $S_2 - S_1 = \int_{T_1}^{T_2} \frac{c_v dT}{T} + \int_{V_1}^{V_2} \frac{R}{V}dV = c_v \ln \frac{T_2}{T_1} + R \ln \frac{V_2}{V_1}$

Similarly,

(ii)  $Tds = dh - dpv$

or,  $ds = \frac{dh}{T} - \frac{V}{T}dp = \frac{c_p dT}{T} - \frac{R}{p}dp$

or,  $S_2 - S_1 = \int_{T_1}^{T_2} \frac{c_p dT}{T} - \int_{p_1}^{p_2} \frac{R}{p}dp = c_p \ln \frac{T_2}{T_1} - R \ln \frac{p_2}{p_1}$

#### EXAMPLE 1.21

A heat engine having an efficiency of 35% is used to run a refrigerator of COP of 4, what is the heat input into the each MJ removed from the cold body by the refrigerator? If this system is used as a heat pump (Figure 1.17), how many MJ of heat would be available for heating for each MJ of heat input to the engine?

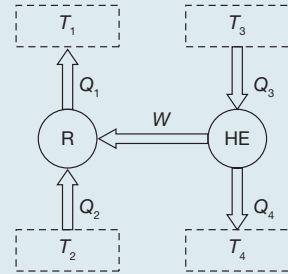
**SOLUTION**

$$COP = 4 = \frac{Q_2}{W}; \quad \eta = 0.35 = \frac{W}{Q_3};$$

$$COP \times \eta = 4 \times 0.35 = 1.4 = \frac{Q_2}{Q_3} = \frac{1}{Q_3} \Rightarrow Q_3 = 0.714 \text{ MJ}$$

$$\text{If } Q_3 = 1; \quad Q_2 = 1.4 \text{ MJ}$$

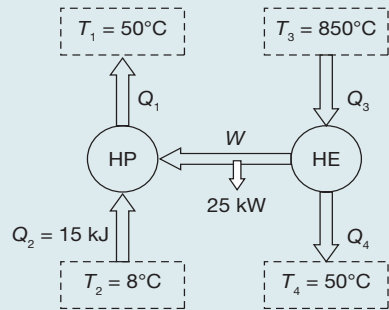
$$W = Q_1 - Q_2 \Rightarrow Q_1 = \frac{Q_2}{COP} + Q_2 = 1.4 \times \frac{5}{4} = 1.75 \text{ MJ}$$


**FIGURE 1.17**

Heat Reservoir and Sink

**EXAMPLE 1.22**

A heat pump working on a Carnot cycle takes in heat from a reservoir at  $8^\circ\text{C}$  and delivers heat to the reservoir at  $50^\circ\text{C}$ . The heat pump is driven by a reversible heat engine taking heat from a reservoir at  $850^\circ\text{C}$  and rejecting heat to a reservoir at  $50^\circ\text{C}$  (Figure 1.18). The reversible heat engine also drives a machine of input required of  $25 \text{ kW}$ . If the heat pump extracts  $15 \text{ kJ/sec}$  from the  $8^\circ\text{C}$  reservoir, determine (a) the rate of heat supply from the  $850^\circ\text{C}$  source and (b) the rate of heat rejection to  $50^\circ\text{C}$  sink.


**FIGURE 1.18**

Heat Pump and Heat Engine

$$\frac{Q_1}{T_1} = \frac{Q_2}{T_2} \Rightarrow Q_1 = Q_2 \times \frac{T_1}{T_2} = 15 \text{ kJ/sec} \times \frac{323 \text{ K}}{281 \text{ K}}$$

$$= 17.241 \text{ kJ/sec}$$

$$W = Q_1 - Q_2 = 17.241 \text{ kJ/sec} - 15 \text{ kJ/sec}$$

$$= 2.241 \text{ kJ/sec}$$

Total work delivered by heat engine =  $W + 25 \text{ kJ/sec} = 27.241 \text{ kJ/sec}$

$$Q_3 - Q_4 = 27.241 \text{ kW} \quad \text{and} \quad \frac{Q_3}{T_3} = \frac{Q_4}{T_4}$$

$$Q_4 = Q_3 \times \frac{323 \text{ K}}{1123 \text{ K}} = 0.287 Q_3$$

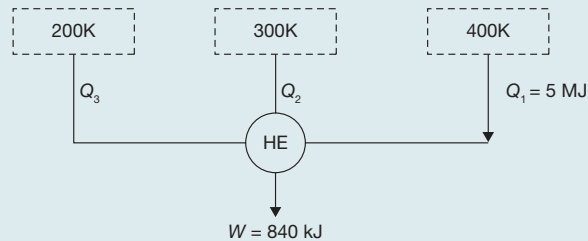
$$Q_3(1 - 0.287) = 27.24 \text{ kW}; \quad Q_3 = 38.20 \text{ kW.}$$

$$\text{Total heat given to } 50^\circ\text{C reservoir} = Q_1 + Q_4 = 17.24 \text{ kW} + 0.287 \times 38.20 \text{ kW}$$

$$= 28.20 \text{ kW.}$$

**EXAMPLE 1.23**

A reversible heat engine as shown in Figure 1.19 during a cycle of operation draws 5 MJ from the 400 K reservoir and does 840 kJ work. Find the amount and direction of heat interaction with other reservoirs.

**FIGURE 1.19**

Reversible Heat Engine

**SOLUTION**

$$Q_1 + Q_2 + Q_3 = 840 \text{ kJ}$$

$$Q_2 + Q_3 = 840 \text{ kJ} - 5,000 \text{ kJ} = -4,160 \text{ kJ} \quad (1.1)$$

$$\Delta S = 0$$

$$\frac{Q_1}{400} + \frac{Q_2}{300} + \frac{Q_3}{200} = 0 \Rightarrow \frac{Q_2}{300} + \frac{Q_3}{200} = -\frac{Q_1}{400}$$

$$3Q_3 + 2Q_2 = -7500 \text{ kJ} \quad (\text{Here } Q_1 = 5 \text{ MJ}) \quad (1.2)$$

Solving Equations (1.1) and (1.2), we get

$$Q_3 = 820 \text{ kJ to the heat engine}$$

$$Q_2 = -4,980 \text{ kJ rejection from heat engine}$$

**EXAMPLE 1.24**

Two blocks of metal each of mass  $M$  and specific heat  $C$ , initially at absolute temperature  $T_1$  and  $T_2$  respectively brought to the same final temperature  $T_f$  by means of reversible process. Derive an expression for the amount of work obtained during the process in terms of  $M$ ,  $C$ ,  $T_1$ , and  $T_2$ .

**SOLUTION**

Let  $T_1 > T_2$  and final temperature be  $T_f$ .

$$\text{Change in entropy in block 1} = \Delta S_1 = M \cdot C \cdot \int_{T_1}^{T_f} \frac{dT}{T} = M \cdot C \cdot \ln \frac{T_f}{T_1}$$

$$\text{Change in entropy in block 2} = \Delta S_2 = M \cdot C \cdot \int_{T_2}^{T_f} \frac{dT}{T} = M \cdot C \cdot \ln \frac{T_f}{T_2}$$

For reversible process, total entropy = 0

$$\Delta S_{total} = M.C \left[ \ln \frac{T_f}{T_1} + \ln \frac{T_f}{T_2} \right] = 0$$

$$\frac{T_f^2}{T_1 T_2} = 1 \Rightarrow T_f = \sqrt{T_1 T_2}$$

$$Q_1 = M.C.(T_1 - T_f); \quad Q_2 = M.C.(T_f - T_2)$$

$$W_{max} = Q_1 - Q_2 = M.C.(T_1 + T_2 - 2T_f) = M.C.(T_1 + T_2 - 2\sqrt{T_1 T_2})$$

### EXAMPLE 1.25

An insulated tank of  $1 \text{ m}^3$  volume contains air at  $0.1 \text{ MPa}$  and  $300 \text{ K}$ . The tank is connected to the high-pressure line in which air at  $1 \text{ MPa}$  and  $600 \text{ K}$  flows. The tank is quickly filled with air by opening the valve between the tank and high-pressure line. If the final pressure of air in the tank is  $1 \text{ MPa}$  (Figure 1.20), determine the mass of air which enters the tank and the entropy change associated with the filling process. Take universal gas constant  $\bar{R} = 0.287 \text{ kJ/kgK}$ .

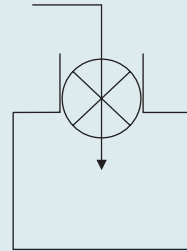


FIGURE 1.20

Insulated Tank

### SOLUTION

$$V_i = \frac{RT_i}{P_i} = \frac{0.287 \text{ kJ/kgK} \times 600 \text{ K}}{1 \times 10^3 \text{ kPa}} = 0.172 \text{ m}^3 / \text{kg}$$

$$P_1 V_i = \frac{R \Delta T}{\gamma - 1} \quad \text{Since } Q = 0; \quad W = \Delta u = C_v \Delta T = \frac{R \Delta T}{\gamma - 1}$$

$$\Delta T = \frac{P_1 V_i (\gamma - 1)}{R} = \frac{1 \times 10^3 \text{ kPa} \times 0.172 \text{ m}^3 \times 0.4}{0.287 \text{ kJ/kgK}} = 240$$

$$T_2 = 240 + T_1 = 240 \text{ K} + 600 \text{ K} = 840 \text{ K}$$

End temperature of entering mass,  $(T_2) = 840 \text{ K}$

$$\text{Initial mass of the air in the cylinder, } m_1 = \frac{P_1 V_1}{RT_1} = \frac{0.1 \times 10^3 \text{ kPa} \times 1 \text{ m}^3}{0.287 \text{ kJ/kgK} \times 300 \text{ K}} = 1.161 \text{ kg}$$

Let the mass of air entered inside the cylinder =  $m_2$

Final temperature of air inside the cylinder =  $T$



$$m_1 T_1 + m_2 T_2 = (m_1 + m_2) T$$

$$T = \frac{m_1 T_1 + m_2 T_2}{(m_1 + m_2)} \quad (1.3)$$

$$m_1 + m_2 = \frac{P_2 V}{RT} \quad (1.4)$$

From Equations (1.3) and (1.4)

$$\frac{P_2 V}{R} = m_1 T_1 + m_2 T_2$$

$$m_2 = \left( \frac{P_2 V}{R} - m_1 T_1 \right) \frac{1}{T_2} = \left( \frac{1 \times 10^3 \text{ kPa} \times 1 \text{ m}^3}{0.287 \text{ kJ / kgK}} - 1.161 \text{ kg} \times 300 \text{ K} \right) \frac{1}{840 \text{ K}}$$

$$= 3.73 \text{ kg}$$

$$\text{Final temperature, } T = \frac{3.733 \text{ kg} \times 840 \text{ K} + 1.161 \text{ kg} \times 300 \text{ K}}{3.733 \text{ kg} + 1.161 \text{ kg}} = 711.90 \text{ K}$$

$$\Delta S_1 = m_1 \left( C_p \ln \frac{T}{T_1} - R \ln \frac{P_1}{P_1} \right)$$

$$= 1.161 \text{ kg} \left( 1.005 \text{ kJ / kg.K} \ln \frac{711.9 \text{ K}}{300 \text{ K}} - 0.287 \text{ kJ / kgK} \ln \frac{1}{0.1} \right)$$

$$= 0.241 \text{ kJ / K}$$

$$\Delta S_2 = m_2 \left( C_p \ln \frac{T}{T_1} - R \ln \frac{P_1}{P_1} \right) = 3.733 \text{ kg} \left( 1.005 \text{ kJ / kg.K} \ln \frac{711.9 \text{ K}}{600 \text{ K}} - 0 \right)$$

$$= 0.641 \text{ kJ / K}$$

Entropy change associated with the process =  $\Delta S_1 + \Delta S_2 = 0.88261 \text{ kJ / K}$

### EXAMPLE 1.26

10 kg of water at 0°C is brought into contact of a heat reservoir at 100°C, where water temperature becomes 100°C. Find the entropy change of water, reservoir and universe.

### SOLUTION

$$\Delta S_{\text{water}} = \int \frac{dQ}{T} = \int_{T_1}^{T_2} \frac{m \cdot C \cdot dT}{T} = m \cdot C \cdot \ln \frac{T_2}{T_1} = 10 \text{ kg} \times 4.18 \text{ kJ / kg.K} \times \ln \frac{373 \text{ K}}{273 \text{ K}} = 13.04 \text{ kJ / K}$$

$$\text{Heat absorbed from reservoir} = m \cdot C \cdot dT = 10 \text{ kg} \times 4.18 \text{ kJ / kg.K} \times 100 \text{ K} = 4,180 \text{ kJ}$$

$$\Delta S_{\text{reservoir}} = \frac{dQ}{T} = -\frac{4180 \text{ kJ}}{373 \text{ K}} = -11.20 \text{ kJ}$$

$$\Delta S_{\text{universe}} = \Delta S_{\text{water}} + \Delta S_{\text{reservoir}} = 13.04 \text{ kJ} - 11.20 \text{ kJ} = 1.833 \text{ kJ}$$

### EXAMPLE 1.27

Calculate the entropy change when 5 kg of water at 20°C is mixed with 5 kg of water at 100°C. The specific heat of water is 4.18 kJ/kg.

### SOLUTION

Let  $T_f$  is final temperature

$$m_1 C_1 (T_f - T_1) = m_2 C_2 (T_2 - T_f). \quad \text{Here, } m_1 = m_2 = 5 \text{ kg and } C_1 = C_2 = 4.18$$

$$T_f = \frac{T_1 + T_2}{2} = \frac{100^\circ\text{C} + 20^\circ\text{C}}{2} = 60^\circ\text{C} = 60^\circ\text{C} + 273 = 333 \text{ K}$$

$$\Delta S = \int_{T_1}^{T_f} \frac{m \cdot C \cdot dT}{T} + \int_{T_2}^{T_f} \frac{m \cdot C \cdot dT}{T} = m \times C \left( \ln \frac{T_f}{T_1} + \ln \frac{T_f}{T_2} \right)$$

$$= 5 \text{ kg} \times 4.18 \text{ kJ/kg.K} \left[ \ln \frac{T_f^2}{T_1 T_2} \right] = 5 \text{ kg} \times 4.18 \text{ kJ/kg.K} \left[ \ln \frac{(333 \text{ K})^2}{293 \text{ K} \times 373 \text{ K}} \right]$$

$$= 303 \text{ kJ}$$

## 1.10 ► THIRD LAW OF THERMODYNAMICS

Third law of thermodynamics is the law of entropy. It is a statement about the ability to create an absolute temperature scale, for which absolute zero is the point at which the internal energy of a solid is zero. Third law of thermodynamics states that it is impossible to reduce any system to absolute zero in a finite series of operations.

## 1.11 ► GAS LAWS

There are some relationships among temperature, volume, pressure, and quantity of a gas that could be described mathematically. This chapter deals with Boyle's law, Charles's law, Gay-Lussac's law, and the combined gas law. These laws have one condition in common, i.e., fixed mass. In addition, some other properties of gases such as internal energy, specific heat capacity, and enthalpy have been introduced. Some of

the important non-flow processes such as a constant volume process, constant pressure process, isothermal processes, polytropic process, and adiabatic process have been explained with suitable examples. Some laws have been proposed by the various chemists such as Boyle's law, Charles's law, Gay-Luccac's law based on the behavior of ideal gases. These laws are discussed in following subsections.

### 1.11.1 Boyle's Law

Robert Boyle, a British chemist gave the first gas law, now known as Boyle's law. This law describes the relationship between the pressure and volume of a sample of gas confined in a container. Boyle observed that when the pressure on an ideal gas is increased volume decreases. Similarly, when pressure is released the volume starts to increase. But Boyle's law is true only when the temperature of the gas remains constant and no additional gas is added to the container or leaks out of the container. On the basis of these observations the Boyle's law is stated as:

*"Boyle's law states that the volume and pressure of a sample of gas are inversely proportional to each other at constant temperature".*

This statement can be expressed as follows.

$$V \propto \frac{1}{P} \quad \text{or} \quad PV = k \quad \text{or} \quad V = k \cdot \frac{1}{P}$$

Where V is the volume and P is the pressure.

For two different conditions 1 and 2, Boyle's law can be expressed as

$$P_1V_1 = P_2V_2$$

Where  $P_1$  and  $V_1$  are the pressure and volume respectively at condition 1 and  $P_2$  and  $V_2$  are the pressure and volume respectively at condition 2.

#### EXAMPLE 1.28

A sample of nitrogen collected in the laboratory occupies a volume of 720 mL at a pressure of 1 atm. What volume will the gas occupy at a pressure of 2 atm, assuming the temperature remains constant?

#### SOLUTION

Given:  $V_1 = 720 \text{ mL}$ ;  $P_1 = 1 \text{ atm}$ ;  $P_2 = 2 \text{ atm}$ ;  $V_2 = ?$

$$P_1V_1 = P_2V_2$$

$$V_2 = \frac{P_1V_1}{P_2} = \frac{1 \text{ atm} \times 720 \text{ mL}}{2 \text{ atm}} = 360 \text{ mL}$$

### 1.11.2 Charles's Law

Jacques Charles carried out experiments on ideal gas and observed a relationship between the absolute temperature and volume of gases at constant pressure. Volume of the gas increases with an increase in temperature and decreases with a decrease in temperature. The Charles's law can be stated as:

*“Charles's law states that the volume of a sample of gas is directly proportional to the absolute temperature when pressure remains constant”.*

Charles's law can be expressed as follows.

$$V \propto T \quad \text{or} \quad \frac{V}{T} = k \quad \text{or} \quad V = k.T$$

Where  $V$  is the volume and  $T$  is the absolute temperature of the gas.

For two different conditions 1 and 2, Boyle's law can be expressed as:

$$\frac{V_1}{T_1} = \frac{V_2}{T_2}$$

where  $T_1$  and  $V_1$  are absolute temperature and volume, respectively at condition 1 and  $T_2$  and  $V_2$  are absolute temperature and volume, respectively at condition 2.

#### EXAMPLE 1.29

A container of a gas has a volume of 360 ml at a temperature of 20°C. What volume will the gas occupy at 60°C?

#### SOLUTION

Given:  $V_1 = 360 \text{ mL}$ ;  $T_1 = 273 + 20 = 293 \text{ K}$ ;  $T_2 = 273 + 60 = 333 \text{ K}$ ;  $V_2 = ?$

$$\frac{V_1}{T_1} = \frac{V_2}{T_2} \Rightarrow V_2 = \frac{V_1 T_2}{T_1} = \frac{360 \text{ mL} \times 333 \text{ K}}{293 \text{ K}} = 409.14 \text{ mL}$$

### 1.11.3 Gay-Lussac's Law

Pressure of a confined gas increases with increasing temperature. If the temperature of the gas increases enough, the container can explode because of the pressure that builds up inside of it. The relationship between the pressure and temperature of a gas is described by Gay-Lussac's law. *“Gay-Lussac's law states that the pressure of a sample of gas is directly proportional to the absolute temperature when volume remains constant”.*

Gay-Lussac's law can be expressed as follows.

$$P \propto T \quad \text{or} \quad \frac{P}{T} = k \quad \text{or} \quad P = k.T$$

where  $P$  is the pressure and  $T$  is the temperature of the gas.

For two different conditions 1 and 2, Gay-Lussac's law can be expressed as

$$\frac{P_1}{T_1} = \frac{P_2}{T_2}$$

where  $T_1$  and  $P_1$  are absolute temperature and pressure, respectively at condition 1 and  $T_2$  and  $P_2$  are absolute temperature and pressure, respectively at condition 2.

### EXAMPLE 1.30

A cylinder of a gas has a pressure of 5 atm at 50°C. At what temperature in °C will it reach a pressure of 12 atm?

#### SOLUTION

Given:  $P_1 = 5 \text{ atm}$ ;  $T_1 = 273 + 50 = 323 \text{ K}$ ;  $P_2 = 12 \text{ atm}$ ;  $T_2 = ?$

$$\frac{P_1}{T_1} = \frac{P_2}{T_2} \Rightarrow T_2 = \frac{P_2 T_1}{P_1} = \frac{12 \text{ atm} \times 323 \text{ K}}{5 \text{ atm}} = 775.2 \text{ K}$$

$$t_1 = 775.2 \text{ K} - 273 = 502.2^\circ \text{C}$$

### 1.11.4 The Combined Gas Law

We have three different relationships among temperature, volume, and pressure of a gas; these are as follows:

**Boyle's Law:**  $PV = k$  at constant temperature.

**Charles's Law:**  $\frac{V}{T} = k$  at constant pressure.

**Gay-Lussac's Law:**  $\frac{P}{T} = k$  at constant volume.

These three gas laws can be combined in one combined gas law. This law can be expressed as:

$$\frac{PV}{T} = k \quad \text{or} \quad \frac{P_1 V_1}{T_1} = \frac{P_2 V_2}{T_2}$$

**EXAMPLE 1.31**

A sample of a gas has a volume of 80.0 mL at a pressure of 1 atm and a temperature of 20°C. What volume will the gas occupy at 1.5 atm and 45°C?

**SOLUTION**

Given:  $V_1 = 80 \text{ mL}$ ;  $P_1 = 1 \text{ atm}$ ;  $T_1 = 273 + 20 = 293 \text{ K}$ ;  $P_2 = 1.5 \text{ atm}$ ;  $T_2 = 273 + 45 = 318 \text{ K}$ ;  $V_2 = ?$

$$\frac{P_1 V_1}{T_1} = \frac{P_2 V_2}{T_2} \Rightarrow V_2 = \frac{P_1 V_1 T_2}{P_2 T_1} = \frac{1 \text{ atm} \times 80 \text{ mL} \times 318 \text{ K}}{1.5 \text{ atm} \times 293 \text{ K}} = 57.88 \text{ mL}$$

**1.11.5 Gas Constant**

Since 1 mole of a gas occupies 22.4 L at standard temperature (273 K) and pressure (1 atm), it is possible to arrive at a mathematical expression to relate moles, pressure, temperature and volume. This expression is called the ideal gas law. This law contains an additional term “R” which is called the universal gas constant. In this expression “N” equals the number of moles of a gas, the volume “V” must be expressed in liters, the pressure “P” must be expressed in atmospheres and the temperature must be expressed in degrees Kelvin.

$$\frac{PV}{T} = NR$$

This constant can be calculated by using the above values in this law.

$$\frac{PV}{NT} = R$$

When the values of 22.4 liters and 273 degrees Kelvin are applied, the value of R is found to be

$$R = \frac{1 \text{ atm} \times 22.4 \text{ l}}{1 \text{ mol} \times 273 \text{ K}} = 0.0821 \frac{\text{atml}}{\text{molK}}$$

If we use CGS units, P will be expressed in dynes per square cm, V is the volume of a mole (i.e., the volume occupied by  $6.0221 \times 10^{23}$  molecules), and the value of the universal gas constant is  $8.3145 \times 10^7 \text{ erg mole}^{-1} \text{ K}^{-1}$ . If we use SI units, P will be expressed in Pascal ( $N \text{ m}^{-2}$ ), V will be the volume of a kilo mole (i.e., the volume occupied by  $6.0221 \times 10^{26}$  molecules), and the value of the universal gas constant is  $8.3145 \text{ J/mole.K}$ .



## RECAP ZONE .....

### Points to Remember

- **Thermodynamics** is a branch of science that deals with the conversion of energy from one form to another form.
- The **system** is the subject of the investigation, which is a fixed quantity of matter and/or a region that can be separated from everything else by a well-defined boundary/surface.
- The defining surface is known as the **control surface** or **system boundary**.
- The control surface may be movable or fixed. Everything beyond the system is the **surroundings**.
- The system plus surroundings, both jointly known as the **universe**.
- At any instant of time, the condition of a system is called a **state**.
- The state at a given instant of time is defined by the properties of the system such as pressure, volume, temperature, etc.
- There are two types of properties—extensive and intensive.
- **Extensive properties** depend on the size or mass of the system. Volume, mass, energy, and entropy are examples of extensive properties.
- An extensive property is additive in the sense that its value for the whole system equals the sum of the values for its molecules.
- **Intensive properties** are independent of the size or extent of the system. Pressure and temperature are examples of intensive properties.
- When any property of a system changes its value there is a change in the state, and the system is said to undergo a **process**.
- When a system from a given initial state goes into a sequence of processes and finally returns to its initial state, it is said to have undergone a **cycle**.
- Phase refers to a quantity of matter that is homogeneous throughout in its chemical composition and physical structure.
- In thermodynamics, the concept of **equilibrium** includes not only a balance of forces, but also a balance of other influencing factors, such as thermal equilibrium, pressure equilibrium, phase equilibrium, etc.
- **Zeroth law of thermodynamics** is law of thermal equilibrium; it states that if a system A is in thermal equilibrium with systems B and C, then systems B and C will be in thermal equilibrium.
- When a process proceeds in such a way that the system remains infinitesimally close to an equilibrium state at all times, it is called a quasi-static process.
- **Temperature** is a property of a substance by which it can be differentiated from other substance in terms of degree of hot or cold.
- The **Internal Energy** ( $U$ ) of a system is the total energy content of the system.
- Work in thermodynamics may be defined as any quantity of energy that flows across the boundary between the system and surroundings.
- Heat is defined as the quantity of energy that flows across the boundary between the system and surroundings because of a temperature difference between system and surroundings.
- Heat transfer to a system and work done by a system are positive.
- Heat transfer from a system and work done on a system are negative.
- The rate of change of internal energy with respect to absolute temperature at constant volume is known as specific heat at constant volume.

- The rate of change of enthalpy with respect to absolute temperature when pressure is constant is known as specific heat at constant pressure.
- **First law of thermodynamics:** (a) When a small amount of work ( $dw$ ) is supplied to a closed system undergoing a cycle, the work supplied will be equal to the heat transfer or heat produced ( $dQ$ ) in the system. (b) If the  $Q$  amount of heat is given to a system undergoing a change of state and  $W$  is work done by the system and transferred during the process, the net energy ( $Q - W$ ) will be stored in the system named as internal energy or simply the energy of the system ( $\Delta U$ ).
- In a steady flow process, thermodynamic properties at any section remain constant with respect to time; it can vary only with respect to space.
- In some flow process, mass flow rate is not steady but varies with respect to time. In such a case, the difference in energy flow is stored in the system as  $\Delta E_v$ .
- The **Second law of thermodynamics:** The Kelvin–Planck statement of the second law can be given as—It is impossible for any system to operate in a thermodynamic cycle and deliver a net amount of energy by work to its surroundings while receiving energy by heat transfer from a single thermal reservoir.
- It is impossible to construct a device that operates in a cycle and produces no effect other than the transfer of heat from a lower temperature body to higher temperature body.
- A process is said to be reversible if it is possible for its effects to be eradicated in the sense that there is some way by which both the system and its surroundings can be exactly restored to their respective initial states. (It is not physically possible; it is an idealization.)
- A process is irreversible if there are no means by which the system and its surroundings can be exactly restored to their respective initial states.
- The thermal efficiency of an irreversible power cycle is always less than the thermal efficiency of a reversible power cycle when each operates between the same two thermal reservoirs.
- All reversible power cycles operating between the same two thermal reservoirs have the same thermal efficiency.
- Entropy is a degree of measurement of disorderness of a system.
- **Third law of thermodynamics** states that it is impossible to reduce any system to absolute zero in a finite series of operations.
- **Boyle's law** states that the volume and pressure of a sample of gas are inversely proportional to each other at a constant temperature.
- **Charles's law** states that the volume of a sample of gas is directly proportional to the absolute temperature when pressure remains constant.
- **Gay–Lussac's law** states that the pressure of a sample of gas is directly proportional to the absolute temperature when volume remains constant.
- The sum of all the microscopic forms of energy is called the internal energy of a system and is denoted by  $U$ .
- Due to different type of movements of molecules, such as translational, rotational and vibrational, the kinetic energy in the system is developed.
- **Internal energy** may be presented in the form of binding force at the atomic level.
- If external energy is supplied to break the bond and to change the phase from solid to liquid or liquid to solid, a certain amount of energy is stored as latent energy. This latent energy represents the internal energy of the system.
- In constant volume process, work done is equal to zero.
- In an adiabatic process, heat transfer is equal to zero.



## Important Formulae

1. Relationship between Celsius and Kelvin:  $^{\circ}C = ^{\circ}K - 273.15$
2. Relationship between Rankine and Kelvin:  $^{\circ}R = 1.8^{\circ}K$
3. Relationship between Fahrenheit and Rankine:  $^{\circ}F = ^{\circ}R - 459.67$
4. Relationship between Fahrenheit and Celsius:  $^{\circ}F = 1.8^{\circ}C + 32$
5. Specific heat capacity at constant volume:  $C_v = \left( \frac{\partial u}{\partial T} \right)_v$
6. Heat to a system at constant volume:  $Q = \Delta u + W = \Delta u + PdV = \Delta u = \int_{T_1}^{T_2} C_v dT$
7. Specific heat at constant pressure:  $C_p = \left( \frac{\partial h}{\partial T} \right)_p$ ; for a constant pressure process.
8. Change in enthalpy:  $\partial h = \partial Q = \int_{T_1}^{T_2} C_p dT$
9. Change in enthalpy:  $\Delta h = c_p \Delta T$
10. Change in internal energy:  $\Delta u = c_v \Delta T$
11.  $c_p \Delta T = c_v \Delta T + R \Delta T$
12.  $c_p = c_v + R$
13.  $\gamma = c_p / c_v$
14. Constant volume process  
 $W = \int p dV = 0$
15.  $Q = \Delta U = m(u_2 - u_1) = m \times c_v dT = m \times c_v (T_2 - T_1) kJ$
16. Constant pressure process  
 $W = p dV = p(V_1 - V_2)$
17.  $Q_{1-2} = \frac{\gamma m R (T_2 - T_1)}{(\gamma - 1)}$
18. Constant temperature process
19.  $Q_{1-2} = W_{1-2} = \int_1^2 P \cdot dV = \int_1^2 \frac{P_1 V_1}{V} dV = P_1 V_1 \ln \left( \frac{V_2}{V_1} \right) = P_1 V_1 \ln \left( \frac{P_1}{P_2} \right) = nRT \ln \left( \frac{P_1}{P_2} \right)$
20. Adiabatic process:  $W_{1-2} = \frac{p_1 V_1 - p_2 V_2}{\gamma - 1} = m c_v (T_2 - T_1)$ ;  $Q_{1-2} = 0$
21. Polytropic process  
 $W_{1-2} = \frac{p_1 V_1 - p_2 V_2}{n - 1}$
22.  $Q_{1-2} = m c_v (T_2 - T_1) \left( \frac{\gamma - n}{1 - n} \right)$

23. Work done in cyclic process:  $\oint dw = \int \oint dQ$

24. Internal energy:  $Q - W = \Delta U$

25. Steady Flow Energy equation (SFEE):

$$m_1 \left( \frac{v_1^2}{2} + Z_1 g + u_1 \right) + m_1 P_1 V_1 + \frac{dQ}{dt} = m_2 \left( \frac{v_2^2}{2} + Z_2 g + u_2 \right) + m_2 P_2 V_2 + \frac{dW}{dt};$$

$$m_1 \left( h_1 + \frac{v_1^2}{2} + Z_1 g \right) + \frac{dQ}{dt} = m_2 \left( h_2 + \frac{v_2^2}{2} + Z_2 g \right) + \frac{dW}{dt}; \quad \text{since } h = u + PV$$

26. Variable flow equation

$$\frac{dE_v}{dt} = \frac{dm_1}{dt} \left( h_1 + \frac{v_1^2}{2} + Z_1 g \right) + \frac{dQ}{dt} - \frac{dm_2}{dt} \left( h_2 + \frac{v_2^2}{2} + Z_2 g \right) + \frac{dW}{dt}$$

$$\Delta E_v = Q - W + \int \left( h_1 + \frac{v_1^2}{2} + Z_1 g \right) dm_1 - \int \left( h_2 + \frac{v_2^2}{2} + Z_2 g \right) dm_2$$

27. Entropy generation:  $\oint \left( \frac{\delta Q}{T} \right)_b = -S_{gen}$

28. Clausius inequality:  $\oint \left( \frac{\delta Q}{T} \right)_b \leq 0$

29. Change in entropy:  $\Delta S = S_2 - S_1 = \sum \frac{Q_k}{T_k} + S_{GEN}$

30. Rate of entropy generation:  $\dot{S}_{GEN} = \sum \dot{m}_e s_e - \sum \dot{m}_i s_i - \sum \frac{\dot{Q}_k}{T}$

31.  $S_2 - S_1 = \int_{T_1}^{T_2} \frac{c_v dT}{T} + \int_{V_1}^{V_2} \frac{R}{V} dV = c_v \ln \frac{T_2}{T_1} + R \ln \frac{V_2}{V_1}$

32.  $S_2 - S_1 = \int_{T_1}^{T_2} \frac{c_p dT}{T} - \int_{p_1}^{p_2} \frac{R}{p} dp = c_p \ln \frac{T_2}{T_1} - R \ln \frac{p_2}{p_1}$

33.  $\Delta S_{system} = S_{transfer} + S_{GEN}$

34. Boyle's law:  $V \propto \frac{1}{P}$  or  $PV = k$  or  $V = k \cdot \frac{1}{P}$

35. Charle's Law:  $V \propto T$  or  $\frac{V}{T} = k$  or  $V = k \cdot T$

36. Gay-Lussac's Law:  $P \propto T$  or  $\frac{P}{T} = k$  or  $P = k \cdot T$

37. Combined gas law:

$$\frac{PV}{T} = k \quad \text{or} \quad \frac{P_1 V_1}{T_1} = \frac{P_2 V_2}{T_2}$$

$$\frac{PV}{T} = NR$$



## REVIEW ZONE

### Multiple-choice Questions

- A closed system is one, which:
  - Permits the passage of energy and matter across boundaries
  - Does not permit the passage of energy and matter across boundaries
  - Permits the passage of energy but does not permit the passage of matter
  - Does not permit the passage of energy but permits the matter
- An isolated system is one, which:
  - Permits the passage of energy and matter across boundaries
  - Permits passage of energy only
  - Does not permit the passage of energy and matter across boundaries
  - Permits the passage of matter only
- A system comprising of single phase is known as:
  - Open system
  - Closed system
  - Homogeneous system
  - Heterogeneous system
- Control volume refers to:
  - A specified mass
  - A fixed region in space
  - A closed system
  - None of the above
- Specific heat is the amount of heat required to raise the temperature:
  - By unit degree of a substance
  - By unit degree of a unit mass
  - Of a unit mass by  $5^{\circ}\text{C}$
  - None of these
- Internal energy of a perfect gas depends upon:
  - Temperature only
  - Temperature and pressure
  - Temperature, pressure and specific heats
  - None of these
- For a closed system, the difference between the heat added to the system and work done by the gas is equal to the change in:
  - Enthalpy
  - Entropy
  - Internal energy
  - Temperature
- The properties of the system, whose value for the entire system is equal to the sum of their values for individual parts of the system, are known as:
  - Thermodynamic properties
  - Extensive properties
  - Intensive properties
  - None of the above
- Temperature of a system is:
  - Thermodynamic properties
  - Extensive properties
  - Intensive properties
  - None of the above
- When two bodies are in thermal equilibrium with a third body, they are also in thermal equilibrium with each other:
  - Zerth law of thermodynamics
  - First law of thermodynamics
  - Second law of thermodynamics
  - None of the above
- The measurement of thermodynamic properties known as temperature is based on:
  - Zerth law of thermodynamics
  - First law of thermodynamics
  - Second law of thermodynamics
  - None of the above
- Heat and work are mutually convertible. This statement is:
  - Zerth law of thermodynamics
  - First law of thermodynamics
  - Second law of thermodynamics
  - None of the above
- Second law of thermodynamics defines:
  - Enthalpy
  - Entropy
  - Heat
  - Work
- Kelvin–Planck's law deals with:
  - Conversion of work into heat
  - Conversion of heat into work
  - Conservation of work
  - Conservation of heat
- According to Kelvin–Planck's statement, a perpetual motion machine:
  - Of first kind is possible
  - Of first kind is impossible
  - Of second kind is impossible
  - Of second kind is possible
- A perpetual motion machine of the first kind, i.e., a machine which produces power without consuming any energy is:
  - Possible according to the first law of thermodynamics

- (b) Impossible according to first law of thermodynamics  
 (c) Impossible according to second law of thermodynamics  
 (d) Possible according to second law of thermodynamics
17. Heat flows from cold substance to hot substance with the aid of external work. This statement is given by:  
 (a) Kelvin (b) Joule  
 (c) Gay Lussac (d) Clausius
18. Specific heat at constant volume is given by:  
 (a)  $\frac{R}{J(\gamma-1)}$  (b)  $\frac{\gamma R}{J(\gamma-1)}$   
 (c)  $\frac{R(\gamma-1)}{J}$  (d)  $\frac{J(\gamma-1)}{R}$
19. Specific heat at constant pressure is given by:  
 (a)  $\frac{R}{J(\gamma-1)}$  (b)  $\frac{\gamma R}{J(\gamma-1)}$   
 (c)  $\frac{R(\gamma-1)}{J}$  (d)  $\frac{J(\gamma-1)}{R}$
20. The condition for reversibility of a cycle is:  
 (a)  $\oint \frac{dQ}{T} < 0$  (b)  $\oint \frac{dQ}{T} > 0$   
 (c)  $\oint \frac{dQ}{T} = 0$  (d) None of the above
21. The condition for irreversibility of a cycle is:  
 (a)  $\oint \frac{dQ}{T} < 0$  (b)  $\oint \frac{dQ}{T} > 0$   
 (c)  $\oint \frac{dQ}{T} = 0$  (d) None of the above
22. If  $\oint \frac{dQ}{T} > 0$ , the cycle is:  
 (a) Reversible (b) Irreversible  
 (c) Impossible (d) None of the above
23. Biogas is produced under anaerobic conditions by the fermentation of biological materials. What is the main constituent of biogas?  
 (a) Butane (b) Ethane  
 (c) Methane (d) Propane
24. A sample of neon gas occupies a volume of 2.8 l at 1.8 atm. What will its volume be at 1.2 atm?  
 (a) 1.2 l (b) 1.8 l  
 (c) 2.2 l (d) 4.2 l
25. The pressure required to compress 48 l of oxygen gas at 99.3 kPa in order to reduce its volume to 16 l is:  
 (a) 198 kPa (b) 278 kPa  
 (c) 298 kPa (d) 320 kPa
26. Volume of sulphur dioxide gas at 0.989 atm is 59 ml. What will be its volume at 0.967 atm?  
 (a) 60.3 ml (b) 68 ml  
 (c) 80 ml (d) 108 ml
27. A sample of hydrogen gas at 6.5 atm pressure occupies a volume of 2.2 l. What will be its volume at 1.15 atm?  
 (a) 10 l (b) 12 l  
 (c) 14 l (d) 16 l
28. A balloon full of air has a volume of 2.75 l at a temperature of 291 K. What will be volume of the balloon at 318 K?  
 (a) 2.10 l (b) 3.01 l  
 (c) 3.5 l (d) 4.12 l
29. A sample of argon gas has a volume of 0.43 ml at 297 K. At what temperature will it have a volume of 0.57 ml?  
 (a) 394 K (b) 294 K  
 (c) 494 K (d) 194 K
30. When the atmospheric pressure is increased on a balloon, the volume of the balloon will:  
 (a) Increase (b) Decrease  
 (c) Stay the same (d) None of these
31. When the temperature of a gas is increased in a balloon, the volume of the balloon will:  
 (a) Increase (b) Decrease  
 (c) Stay the same (d) None of these
32. When the volume of a gas is decreased, the pressure of the gas will:  
 (a) Increase (b) Decrease  
 (c) Stay the same (d) None of these
33. A balloon is filled with helium gas to a pressure of 107 kPa when the temperature is 295 K. If the temperature changes to 318 K, what will be the pressure of the helium in the balloon?  
 (a) 115 kPa (b) 125 kPa  
 (c) 135 kPa (d) 145 kPa
34. An isothermal process is governed by:  
 (a) Boyle's law (b) Charle's law  
 (c) Joule's law (d) Gay Lussac's law
35. When the expansion follows the law  $PV^n = C$ , the process is:  
 (a) Isothermal process  
 (b) Adiabatic process  
 (c) Polytropic process  
 (d) Hyperbolic process
36. Real gas follows the relation:  
 (a)  $PV = RT$  (b)  $PV^n = RT$   
 (c)  $PV = nRT$  (d)  $(PV)^n = C$
37. For real gas,  $C_p = C_v$ , at:  
 (a) Absolute zero (b) Critical temperature  
 (c) Triple point (d) All temperature

## Fill in the Blanks

38. The system and surrounding together constitute \_\_\_\_\_ system.
39. In an adiabatic process, energy can be exchanged in the form of \_\_\_\_\_.
40. For an ideal gas  $(dh/dT)$  is a measure of \_\_\_\_\_ at constant pressure.
41. Second law of thermodynamics establishes the law of \_\_\_\_\_.
42. The slope of constant volume line on  $T$ - $S$  diagram is \_\_\_\_\_ than that of constant pressure line.
43. The unit of entropy is \_\_\_\_\_.
44. In case of free expansion enthalpy \_\_\_\_\_.
45. The entropy of universe tends to be \_\_\_\_\_.

## Answers

- |                      |                      |          |                   |             |          |
|----------------------|----------------------|----------|-------------------|-------------|----------|
| 1. (c)               | 2. (c)               | 3. (c)   | 4. (b)            | 5. (b)      | 6. (a)   |
| 7. (c)               | 8. (b)               | 9. (c)   | 10. (a)           | 11. (a)     | 12. (b)  |
| 13. (b)              | 14. (b)              | 15. (c)  | 16. (b)           | 17. (d)     | 18. (a)  |
| 19. (b)              | 20. (c)              | 21. (a)  | 22. (c)           | 23. (c)     | 24. (d)  |
| 25. (c)              | 26. (a)              | 27. (b)  | 28. (b)           | 29. (a)     | 30. (b)  |
| 31. (a)              | 32. (a)              | 33. (a)  | 34. (a)           | 35. (c)     | 36. (c)  |
| 37. (a)              | 38. Isolated         | 39. Heat | 40. Specific heat | 41. Entropy | 42. More |
| 43. $\text{kJ/kg K}$ | 44. Remains constant |          | 45. Maximum       |             |          |

## Theory Questions

- Define: (i) property, (ii) state, (iii) system, (iv) control volume, and (v) process.
- Discuss the concept of thermal equilibrium and state zeroth law of thermodynamics.
- \*3. What do you understand by quasi-static process? How it is achieved?
- Differentiate among temperature, heat, and internal energy.
- \*5. Derive an expression for the first law of thermodynamics applied to a closed system. Define the internal energy of a system.
- Define work. Show that work done  $W = PdV$ .
- Discuss the thermodynamic system, surrounding, and universe. Also Discuss the various types of system with suitable example.
- Prove that work and heat are the path function.
- Derive the expression for work done in steady flow process.
- Distinguish between the term 'change of state', 'path', and 'process'.
- \*11. State the zeroth law of thermodynamics and first law of thermodynamics.
- Explain and derive steady flow energy equation (SFEE).
- \*13. State the Kelvin-Planck and the Clausius statements of the second law of thermodynamics. Explain the equivalence of Kelvin-Planck and Clausius statements.
- State and explain Carnot theorem.
- \*15. Write the statement of Boyle's law.

\* indicates that similar questions have appeared in various university examinations.

- \*16. Write the statement of Charle's law.
- \*17. Write the statement of Gay–Lussac's law.
  - 18. Derive the expression for combined gas law.
- \*19. Discuss about entropy and available energy?
- \*20. Explain air standard Carnot cycle with PV and TS diagram and write its efficiency?
- \*21. Discuss about entropy and Clausius inequality.
- \*22. Define open, closed and isolated systems. Classify each with example.
- \*23. Differentiate among heat, work and internal energy.
- \*24. Derive  $C_p - C_v = R$ , with usual notations.
- \*25. Define the isothermal process. Derive the expression for work done, change in internal energy and heat transfer for this process.
- \*26. Define the following terms:
  - (i) Absolute pressure and Atmospheric pressure.
  - (ii) Enthalpy and Energy.

## Numerical Problems

1. An ideal gas is heated from 25°C to 145°C. The mass of the gas is 2kg. Determine: (i) specific heats, (ii) change in internal energy, (iii) change in enthalpy. Assume  $R = 287 \text{ J/kgK}$  and  $\gamma = 1.4$  for the gas.
2. A single stage compressor is required to compress 94 m<sup>3</sup> air per min from 1bar and 25°C to 9 bar. Find the temperature at the end of compression, work done, the power required and heat rejected during each of the following process: (i) isothermal, (ii) adiabatic, (iii) Polytropic following the law  $PV^{1.3} = \text{constant}$ . Assume no clearance.
3. Determine the work done in compressing 1 kg of air from a volume of 0.15m<sup>3</sup> at a pressure of 1 bar to a volume of 0.05m<sup>3</sup>, when the compression is (i) isothermal and (ii) adiabatic, take  $\gamma = 1.4$ .
4. 0.15m<sup>3</sup> of air at a pressure of 900 kPa and 300°C is expanded at constant pressure to three times its initial volume, It is expanded polytropically following the law  $PV^{1.5} = C$  and finally compressed back to initial state isothermally. Calculate heat received, heat rejected, efficiency of the cycle.
5. In an air compressor, air enters at 1.013bar and 27°C having volume 5 m<sup>3</sup>/kg and it is compressed to 12bar isothermally. Determine work done, heat transfer, and change in internal energy.
6. The work and heat per degree change of temperature for a process executing a non flow process is given by  $\frac{\delta W}{\delta T} = 160 \text{ W / } ^\circ\text{C}$  and  $\frac{\delta Q}{\delta T} = 200 \text{ J / } ^\circ\text{C}$ . Determine change in internal energy of a system when its temperature increases from 60°C to 110°C.
7. A blower handles 2 kg/sec. of air at 30°C and consumes 40 kW power. The inlet and outlet velocities of air are 100 m/sec. and 150 m/sec. respectively. Find exit temperature assuming the process is adiabatic. (Take  $C_p$  for air 1.005 kJ/kgK)
8. The centrifugal pump delivers 50kg of water per second. The inlet and outlet pressures are 1 bar and 4.2bar respectively. The suction is 2.2 m below the center of the pump and delivery is 8.5 m above the center of the pump. The suction and delivery pipe diameters are 20 and 10 cm, respectively. Determine the capacity of the electric motor to run the pump.
9. Two reversible heat engine  $E_1$  and  $E_2$  are arranged in series between a hot reservoir at temperature  $T_1$  of 600 K and a cold reservoir at temperature  $T_2$  of 300K. Engine  $E_1$  receives 500 kJ of heat from a reservoir at  $T_1$ . Presuming both engines have equal thermal efficiency, determine—the temperature at which heat is rejected by  $E_1$  and received by  $E_2$ , the thermal efficiency of each engine, work done by engine  $E_1$  and  $E_2$ , and heat rejected by  $E_2$  to a cold reservoir.
10. A reversible heat engine operates between 875 K and 310 K and drives a reversible refrigerator operating between 310 K and 255 K. The engine receives 2000 kJ of heat and net work output from the arrangement equals 350 kJ. Make calculations for cooling effect.
11. A new temperature scale in degree N is desired with a freezing point at 100°N and the boiling point at 400°N. Establish a correlation between

\* indicates that similar questions have appeared in various university examinations.

degrees Celsius and degrees N. What would be the absolute temperature at 0°N?

12. A reversible heat engine operates within the higher and lower temperature limits of 1400K and 400K respectively. The entire output from this engine is utilized to operate a heat pump. The pump works on a reversed Carnot cycle, extracts heat from a reservoir at 300K and delivers it to the reservoir at 400K. If 100 kJ/sec. of net heat is supplied to the reservoir at 400K, calculate the heat supplied to the engine by a reservoir at 1400 K.
  13. A sample of a gas with a volume of 575 ml and a pressure of 756 mm has to be given a volume of 375 ml. What pressure is needed if the temperature is kept constant?
  14. What is the new pressure on a sample of gas that has an initial volume of 1.4 L and a pressure of 750 mm if the volume becomes 2.2 L at the same temperature?
  15. A balloon contains a gas with a volume of 1.1 L at 22°C and 756 mm. What would be the volume of the gas at a higher altitude where the pressure of the gas in the balloon decreases to 500 mm? Assume the temperature remains the same.
  16. How many liters will 10 g of dry ice (carbon dioxide) occupy at 1 atm and 23°C?
- \*17. One kg of gas is compressed polytropically from 160 kPa pressure and 280 K temperature to 760 kPa. The compression is according to law  $PV^{1.3} = \text{Constant}$ . Find: (i) Final Temperature (ii) work done (iii) change in internal energy (iv) amount of heat transfer, and (v) change in enthalpy. Take  $R = 0.287 \text{ KJ/KgK}$  and  $C_p = 1.002 \text{ KJ/KgK}$ .  
[Hint: Refer Example 1.14]
  - \*18. One cubic meter of air at a pressure of 1.5 bar and 80°C is compressed to final pressure 8 bar and volume 0.28 m<sup>3</sup>. Determine: (i) mass of air, (ii) index of 'n' compression, (iii) change in internal energy, and (iv) Heat transfer during compression. Take  $\gamma = 1.4$  and  $R = 287 \text{ J/kgK}$ .  
[Hint:  $m = \frac{P_1 V_1}{RT_1}$ ;  $n = \ln\left(\frac{P_2}{P_1}\right) - \ln\left(\frac{V_1}{V_2}\right)$  and Refer Example 1.14]
  - \*19. A cylinder contains 0.6 m<sup>3</sup> of gas at a pressure of 1 bar and 90° C the gas is compressed to a volume of 0.18 m<sup>3</sup> according to law  $PV^n = C$ . The final pressure is 5 bar. Assuming  $R = 0.287 \text{ KJ/Kg K}$  and  $\gamma = 1.4$  Calculate: (i) The mass of gas, and (ii) The Value of Index  $n$  for compression.  
[Hint:  $m = \frac{P_1 V_1}{RT_1}$ ;  $n = \ln\left(\frac{P_2}{P_1}\right) - \ln\left(\frac{V_1}{V_2}\right)$  and Refer Example 1.14]

# Fuels and Combustion

## Learning Objectives

*By the end of this chapter, the student will be able:*

- To differentiate the solid, liquid, and gaseous form of fossil fuels
- To describe the method for preparation of biofuels
- To demonstrate the experimental set up to determine the calorific value of the fuel

## 2.1 ► INTRODUCTION

Any material that can be burned to release thermal energy is called a fuel. Most familiar fuels consist primarily of hydrogen and carbon, called hydrocarbon fuels. Hydrocarbon fuels exist in all phases; some examples are coal, gasoline, and natural gas. Fuels are the materials which ignite in presence of oxygen and produce heat. The heat energy is then converted into various forms of energy. The different types of fuels like liquid, solid and gaseous fuels are available for firing in boiler's furnaces and other combustion equipments. The selection of right type of fuels depends on various factors such as availability, storage, handling, pollution and landed cost of fuel.

The knowledge of the fuel properties helps in selecting the right fuel for the right purpose and efficient use of the fuel. The increasing worldwide demand for energy has focused attention on fuels, their availability and environmental effects. The fuels available to produce electricity are largely nuclear and fossil, both essentially non-renewable. Fossil fuels take nature's millions of years to manufacture. Fossil fuels originate from the earth as a result of the slow decomposition and chemical conversion of organic material. They exist in nature in three basic forms—solid (coal), liquid (oil) and natural gas. Coal represents the largest fossil-fuel energy resource in the world.



The use of various types of fuels plays an important role in global warming. Global warming means a gradual increase in the average temperature of the Earth's atmosphere and oceans and a permanent change in the Earth's climate. There is great debate regarding the reality of global warming. But scientists looking at the data and facts agree that the planet is warming. While many view the effects of global warming to be more substantial and more rapidly occurring than others do, the scientific consensus on climatic changes related to global warming is that the average temperature of the Earth has risen between 0.4 and 0.8°C over the past 100 years. It has been predicted that average global temperatures could increase between 1.4 and 5.8°C by the year 2100. Changes resulting from global warming may include rising sea levels due to the melting of the polar ice caps, as well as an increase in occurrence and severity of storms and other severe weather events.

Global warming occurs due to a collection of carbon dioxide (CO<sub>2</sub>) and other air pollutants and greenhouse gasses in the atmosphere and absorption of sunlight and solar radiation that have bounced off the earth's surface. Normally, this radiation would escape into space, but these pollutants, which can last for years to centuries in the atmosphere, trap the heat and cause the planet to get hotter. That is known as the greenhouse effect.

The global warming may affect the environmental, economic, and health of the living beings on the earth in the following terms:

- ▶ Melting the glaciers, early snowmelt, and severe droughts may cause more dramatic water shortages and increase the risk of wildfires.
- ▶ Rising sea levels may lead to coastal floodings like Mumbai and Kolkata area. Forests, farms, and cities may face troublesome new pests, heat waves, heavy downpours, and increased flooding. All those factors may damage or destroy agriculture and fisheries.
- ▶ Disruption of habitats such as coral reefs and Alpine meadows could drive many plant and animal species to extinction.
- ▶ Allergies, asthma, and infectious disease outbreaks may become more common due to increased growth of pollen-producing ragweed and higher levels of air pollution.

## 2.2 ► COAL

Coal is classified into three major classes, namely anthracite, bituminous, and lignite. However, there is no clear demarcation between them and coal is also further classified as semi-anthracite, and sub-bituminous. Anthracite is the oldest coal from a geological perspective. It is a hard coal composed mainly of carbon with little volatile content and practically no moisture. Lignite is the youngest coal from a geological perspective. It is a soft coal composed mainly of volatile matter and moisture content with low fixed carbon. Fixed carbon refers to carbon in its free state, not combined with other elements. Volatile matter refers to those combustible constituents of coal that vaporize when coal is heated. The common coals

used in Indian industry are bituminous and sub-bituminous coal. The gradation of Indian coal based on its calorific value is given in Table 2.1.

**Table 2.1: Calorific values of various grades of Indian Coals**

Grade	Calorific Value Range ( in kCal/kg)
A	Exceeding 6200
B	5600 – 6200
C	4940 – 5600
D	4200 – 4940
E	3360 – 4200
F	2400 – 3360
G	1300 – 2400

### 2.2.1 Analysis of Coal

There are two methods for coal analysis—ultimate and proximate analysis. The ultimate analysis determines all solid or gaseous coal components, and the proximate analysis determines only the percentage of carbon, volatile matter, moisture, and ash.

**Ultimate Analysis:** The ultimate analysis indicates the various chemical constituents such as Carbon, Hydrogen, Oxygen, Sulfur, etc. It is useful in determining the quantity of air required for combustion and the volume and composition of the combustion gases. This information is required for the calculation of flame temperature and the flue duct design, etc.

**Proximate Analysis:** Proximate analysis indicates the percentage by weight of the Fixed Carbon, Volatiles, Ash, and Moisture Content in coal. The amounts of fixed carbon and volatile combustible matter directly contribute to the heating value of coal. Fixed carbon acts as a main heat generator. The high volatile matter content indicates easy ignition of the fuel. The ash content is important in the design of the furnace grate, combustion volume, and pollution control equipment and ash handling systems of a furnace. *Fixed Carbon*—Fixed carbon is the solid fuel left in the furnace after the volatile matter is distilled off. It consists of carbon but also contains some hydrogen, oxygen, sulfur, and nitrogen not driven off with the gases. Fixed carbon gives a rough estimate of the heating value of coal. *Volatile Matter*—Volatile matters are the methane, hydrocarbons, hydrogen and carbon monoxide, and incombustible gases like carbon dioxide and nitrogen found in coal. Thus, the volatile matter is an index of the gaseous fuels present. Typical range of volatile matter is 20 to 35%. Volatile matter proportionately increases flame length, and helps in easier ignition of coal, sets the minimum limit on the furnace height and volume, influences secondary air requirement and distribution aspects and also influences secondary oil support.

*Ash Content:* Ash is an impurity that does not burn. It ranges from 5 to 40%. Ash reduces handling and burning capacity, increases handling costs, affects combustion efficiency and boiler efficiency and causes clinkering and slagging. *Moisture Content*—Moisture in coal must be transported, handled and stored. Since it replaces combustible matter, it decreases the heat content per kg of coal. It ranges from 0.5 to 10%. Moisture increases heat loss due to evaporation and superheating of vapor.

*Sulfur Content:* It ranges from 0.5 to 0.8%. Sulfur affects clinkering and slagging tendencies, corrodes chimney, and other equipment such as air heaters and economizers, and limits exit flue gas temperature.

## 2.2.2 Advantages of Solid Fuels over the Liquid Fuels

- ▶ In case of liquid fuels, there is a chance of explosion.
- ▶ Liquid fuels are costlier in comparison to solid fuels.
- ▶ Sometimes liquid fuels give unpleasant odors during burning.
- ▶ Liquid fuels require special types of burners for burning.
- ▶ Liquid fuels pose problems in cold climates since the oil stored in the tanks is to be heated in order to avoid the stoppage of oil flow.

## 2.3 ► LIQUID FUELS

### 2.3.1 Petroleum

Petroleum means ‘rock oil’, as it is found underground in porous rocks. It is often used synonymously for ‘Crude Oil’, ‘Crude Petroleum’, or simply ‘Oil’. Petroleum is a dark colored liquid with the potential to release energy to generate heat through combustion and is the source of a wide range of industrial liquid fuels for process heating and power generation. Though its composition varies with geological location, a general indication of the chemical composition (by weight) of petroleum would be—C(84%); H(14%); S(1–3%); N(<1%); O(<1%); metals and salts (<1%). The value of petroleum is high due to its ease of storage, transportation, utilization, high stored-energy density and relative ease of conversion to thermal energy. The primary use of petroleum fuel is for transportation, with industrial process heating and power applications also accounting for significant consumption.

The major source of liquid fuels is crude petroleum; other sources are shale and tar sands. Synthetic hydrocarbon fuels such as gasoline and methanol can be made from coal and natural gas. Ethanol, some of which is used as an automotive fuel, is derived from vegetable matter.

Crude petroleum and refined products are a mix of a wide variety of hydrocarbons—aliphatic (straight or branched chained paraffins and olefins), aromatics (closed rings, six carbons per ring with alternate double bonds joining the ring carbons, with or without aliphatic side chains), and naphthenic or cycloparaffins (closed single-bonded carbon rings, five to six carbons). Refining is required to yield marketable products that are separated by distillation into fractions, including a specific boiling range. Further processing (such as cracking, reforming, and alkylation) alters the molecular structure of some of the hydrocarbons and enhances the yield and properties of the refined products.

### 2.3.2 Kerosene

Kerosene is a refined petroleum distillate consisting of a homogeneous mixture of hydrocarbons. It is used mainly in wick-fed illuminating lamps and kerosene burners. Oil for illumination and for domestic stoves must be high in paraffin to give low smoke. The presence of naphthenic and especially aromatic hydrocarbons increases the smoking tendency. A “smoke point” specification is a measure of flame height at which the tip becomes smoky. The “smoke point” is about 73 mm for paraffin, 34 mm for naphthalene, and 7.5 mm for aromatics and mixtures.

Low sulfur content is necessary for kerosene because:

- ▶ Sulfur forms a bloom on glass lamp chimneys and promotes carbon formation on wicks.
- ▶ Sulfur forms oxides in heating stoves. These swells, are corrosive and toxic, creating a health hazard, particularly in non-vented stoves.

### 2.3.3 Diesel

Diesel engines, developed by Rudolf Diesel, rely on the heat of combustion of the fuel. Fuel is injected into the combustion chamber in an atomized spray at the end of the compression stroke after air has been compressed to 450–650 psi and has reached a self-ignition temperature due to compression of at least 500°C. This temperature ignites the fuel and initiates the piston’s power stroke. The fuel is injected at about 2000 psi to ensure good mixing. Diesel is expensively used in truck transport, rail trains, and marine engines. They are being used more in automobiles. In addition, they are employed in industrial and commercial stationary power plants. Fuels for diesel vary from kerosene to medium residual oils. The choice is dictated by engine characteristics, namely, cylinder diameter, engine speed, and combustion wall temperature. High speed small engines require lighter fuels and are more sensitive to fuel quality variations. Slow-speed, larger industrial and marine engines use heavier grades of diesel fuel oil. Ignition qualities and viscosity are important characteristics that determine performance. The ignition qualities of diesel fuels may be assessed in terms of their cetane numbers or diesel indices.

### 2.3.4 Gasoline

Gasoline, or petrol, is made of a mixture of hydrocarbons, which are molecules composed of carbon and hydrogen atoms. Typically, in standard gasoline, the hydrocarbons consist of carbon chains are 5–10 carbon atoms long. The exact mixture of which types of hydrocarbons depends entirely on the specific sample of gasoline (what type of oil it was made from, which company refined it, what additives were added, etc.). Gasoline is more volatile than diesel oil, or kerosene, not only because of the base constituents but also because of the additives. Volatility is often controlled by blending with butane, which boils at  $-0.5\text{ }^{\circ}\text{C}$ . The volatility of petrol is determined by the Reid vapor pressure (RVP) test. The desired volatility depends on the ambient temperature. In hot weather, petrol components of higher molecular weight and thus lower volatility are used. In cold weather, too little volatility results in cars failing to start.

In hot weather, excessive volatility results in what is known as “vapor lock”, where combustion fails to occur, because the liquid fuel has changed to a gaseous fuel in the fuel lines, rendering the fuel pump ineffective and starving the engine of fuel.

### 2.3.5 Calorific Value of Liquid Fuels

The calorific value is the measurement of heat or energy produced and is measured in terms of gross calorific value or net calorific value. Gross calorific value (GCV) assumes all vapor produced during the combustion process is fully condensed. Net calorific value (NCV) assumes the water leaves with the combustion products without fully being condensed. Fuels should be compared based on the net calorific value.

The calorific value of coal depends on the ash, moisture content and the type of coal. The typical Gross Calorific Values of some of the commonly used liquid fuels are as—Kerosene oil (11,100 kCal/kg), Diesel oil (10,800 kCal/kg), Light Diesel Oil (LDO) (10,700 kCal/kg), Furnace oil (10,500 kCal/kg), and Low Sulfur Heavy Stock(LSHS) (10,600 kCal/kg).

### 2.3.6 Major Contents of Liquid Fuels

#### *Sulfur*

The amount of sulfur in the fuel oil depends mainly on the source of the crude oil and to a lesser extent on the refining process. The normal sulfur content in the residual fuel oil (furnace oil) is in the order of 2–4%. The ranges of variation of sulfur in liquid fuels in percentage are as—Kerosene oil (0.05–0.2), Diesel oil (0.05–0.25), Light Diesel Oil (LDO) (0.5–1.8), Furnace oil (2.0–4.0), and Low Sulfur Heavy Stock (LSHS) (less than 0.5).

The main disadvantage of sulfur is the risk of corrosion by sulfuric acid formed during and after combustion, and condensing in cool parts of the chimney or stack, air preheater, and economizer.

### *Ash Content*

The ash value is related to the inorganic material in the fuel oil. The ash levels of distillate fuels are negligible. Residual fuels have more of the ash-forming constituents. These salts may be compounds of sodium, vanadium, calcium, magnesium, silicon, iron, aluminum, nickel, etc.

Typically, the ash value is in the range 0.03-0.07%. Excessive ash in liquid fuels can cause fouling deposits in the combustion equipment. Ash has an erosive effect on the burner tips, causes damage to the refractories at high temperatures and gives rise to high-temperature corrosion and fouling of equipment.

### *Carbon Residue*

Carbon residue indicates the tendency of oil to deposit a carbonaceous solid residue on a hot surface, such as a burner or injection nozzle, when its vaporizable constituents evaporate. The residual oil contains carbon residue ranging from 1 per cent or more.

### *Water Content*

The water content of furnace oil when supplied is normally very low as the product at refinery site is handled hot and maximum limit of 1% is specified in the standard. Water may be present in free or emulsified form and can cause damage to the inside furnace surfaces during combustion especially if it contains dissolved salts. It can also cause extinguishing the flame and reducing the flame temperature or lengthening the flame.

## **2.3.7 Advantages and Disadvantages of Liquid Fuels over Solid Fuels**

### *Advantages*

- ▶ Handling of liquid fuel is easy and they require less storage space.
- ▶ Liquid fuels can be fired easily and the maximum temperature is attained in less time than that of solid fuels.
- ▶ The solid fuels containing higher of moisture burn with great difficulty.
- ▶ The solid fuels leave a large quantity of ash after burning and then disposal of ash becomes a problem, whereas the liquid fuels as very little ash after burning. The combustion of liquid fuel is uniform, therefore, the change in load can be easily met by controlling the flow of fluid.

### *Disadvantages*

- ▶ They are costly as compared to solid fuels.
- ▶ They require special type of burners.
- ▶ In cold climate, the oil stored in tanks is to be heated in order to avoid the stoppage of flow.

## 2.4 ► GASEOUS FUELS

Gaseous fuels in common use are liquefied petroleum gases (LPG), Natural gas, producer gas, blast furnace gas, coke oven gas, etc. The calorific value of gaseous fuel is expressed in kilocalories per normal cubic meter (kCal/Nm<sup>3</sup>), i.e., at normal temperature (20°C) and pressure (760 mm Hg).

### 2.4.1 Liquefied Petroleum Gases (LPG)

LPG is a predominant mixture of propane and Butane with a small percentage of unsaturates (Propylene and Butylene) and some lighter C<sub>2</sub> as well as heavier C<sub>5</sub> fractions. Included in the LPG range are propane (C<sub>3</sub>H<sub>8</sub>), Propylene (C<sub>3</sub>H<sub>6</sub>), normal and iso-butane (C<sub>4</sub>H<sub>10</sub>) and Butylene (C<sub>4</sub>H<sub>8</sub>). LPG may be defined as those hydrocarbons, which are gaseous at normal atmospheric pressure, but may be condensed to the liquid state at normal temperature, by the application of moderate pressures. Although they are normally used as gases, they are stored and transported as liquids under pressure for convenience and ease of handling. Liquid LPG evaporates to produce about 250 times volume of gas.

LPG vapor is denser than air—butane is about twice as heavy as air and propane about one and a half times as heavy as air. Consequently, the vapor may flow along the ground and into drains, sinks to the lowest level of the surroundings and be ignited at a considerable distance from the source of leakage. In still air vapor will disperse slowly. Escape of even small quantities of the liquefied gas can give rise to large volumes of vapor/air mixture and thus cause a considerable hazard. To aid in the detection of atmospheric leaks, all LPG's are required to be odorized. There should be adequate ground level ventilation where LPG is stored. For this very reason, LPG cylinders should not be stored in cellars or basements, which has no ventilation at ground level.

### 2.4.2 Compressed Natural Gas (CNG)

Methane is the main constituent of Natural gas and accounting for about 95% of the total volume. Other components are—Ethane, Propane, Butane, Pentane, Nitrogen, Carbon Dioxide, and traces of other gases. Very small amounts of sulfur compounds are also present. Since methane is the largest component of natural gas, generally, properties of methane are used when comparing the properties of the natural gas to other fuels. Natural gas is a high calorific value fuel requiring no storage facilities. It mixes with air readily and does not produce smoke or soot. It has no sulfur content. It is lighter than air and disperses into air easily in case of a leak. CNG (Compressed Natural Gas) is made by compressing natural gas (which is mainly composed of methane [CH<sub>4</sub>]), to less than 1% of the volume, it occupies at standard atmospheric pressure. It is stored and distributed in hard containers at a pressure of 200–248 bar, usually in cylindrical or spherical shapes.

### 2.4.3 Advantages and Disadvantages of Gaseous Fuels over the Solid Fuels

#### *Advantages*

- ▶ Gaseous fuels are easier to handle than solid fuels.
- ▶ Gaseous fuels can be transported easily through pipelines whereas solid fuels cannot be transported in this way.
- ▶ Gaseous fuels do not leave any residue after burning.
- ▶ Gaseous fuels have higher calorific values than the solid fuels. In other words, for a given mass of the fuel, liquid and gaseous fuels produce more heat.
- ▶ Gaseous fuels produce little or no smoke, whereas most of the solid fuels burn with smoke.
- ▶ Gaseous fuels have relatively low ignition temperature and hence they burn more easily than solid fuels.

#### *Disadvantages*

- ▶ Very large storage tanks are required for storing gaseous fuels.
- ▶ Gaseous fuels are highly inflammable, so chances of fire hazards are high in their use.
- ▶ Gaseous fuels are more costly than solid or liquid fuels.

## 2.5 ► BIOFUELS

A biofuel is derived from biological carbon fixation. Biofuels include fuels derived from biomass conversion, as well as solid biomass, liquid fuels, and various biogases. Fossil fuels having their origin in ancient carbon fixation are not considered biofuels because they contain carbon that has been out of the carbon cycle for a very long time.

Bioethanol is an alcohol made by fermentation of carbohydrates produced in sugar or starch crops such as corn or sugarcane. Cellulosic biomass, derived from non-food sources such as trees and grasses, is also being developed as a feedstock for ethanol production. Ethanol can be used as a fuel for vehicles in its pure form, but it is usually used as a gasoline additive to increase octane and improve vehicle emissions.

Biodiesel is made from vegetable oils and animal fats. Biodiesel can be used as a fuel for vehicles in its pure form, but it is usually used as a diesel additive to reduce levels of particulates, carbon monoxide, and hydrocarbons from diesel-powered vehicles. Biodiesel is produced from oils or fats using transesterification.

### 2.5.1 Bioalcohols

Bioalcohols are produced by the action of microorganisms and enzymes through the fermentation of sugars or starches or cellulose. Biobutanol is also known as biogasoline as claimed



to provide a direct replacement for gasoline because it can be used directly in a gasoline engine. Ethanol can be used in petrol engines as a replacement for gasoline; it can be mixed with gasoline to any percentage. Most existing car petrol engines can run on blends of up to 15% bioethanol with petroleum/gasoline. Ethanol has a smaller energy density than does gasoline; this fact means that it takes more fuel (volume and mass) to produce the same amount of work. An advantage of ethanol is that it has a higher octane rating than ethanol-free gasoline available at roadside gas stations, which allows an increase of an engine's compression ratio for increased thermal efficiency.

**Ethanol:** It can be produced using any feedstock containing significant amounts of sugar, such as sugarcane, sugar beet, starch, maize, and wheat, etc. Sugarcane can be directly fermented to alcohol, but starch is first required to be converted to sugar. The fermentation process is a type of distillation process, which is commonly used for producing wine or beer. The main producers are Brazil and the USA.

Ethanol can be mixed with petrol or burned in almost pure form in slightly modified spark-ignition engines. A liter of ethanol contains approximately two-thirds of the energy provided by a liter of petrol. However, when mixed with petrol, it improves the combustion performance and lowers the emissions of carbon monoxide and sulfur oxide.

Methanol is currently produced from natural gas, a non-renewable fossil fuel. It can also be produced from biomass as biomethanol. The methanol economy is an alternative to the hydrogen economy, compared to today's hydrogen production from natural gas.

### 2.5.2 Biodiesel

Biodiesel is produced from oils or fats using transesterification and is a liquid similar in composition to fossil/mineral diesel. Chemically, it consists mostly of fatty acid methyl esters (FAMES). Feedstocks for biodiesel include animal fats, vegetable oils, soya, rapeseed, jatropha, mahua, mustard, flax, sunflower, palm oil, hemp, field pennycress, pongamia pin-nata and algae. Pure biodiesel (B100) is the lowest emission diesel fuel. Although liquefied petroleum gas and hydrogen have cleaner combustion, they are used to fuel much less efficient petrol engines and are not as widely available.

### 2.5.3 Green Diesel

Green diesel, also known as renewable diesel, is a form of diesel fuel, which is derived from renewable feedstock rather than the fossil feedstock used in most diesel fuels. Green diesel feedstock can be sourced from a variety of oils including canola, algae, jatropha, and salicornia in addition to tallow. Green diesel uses traditional fractional distillation to process the oils, not to be confused with biodiesel, which is chemically quite different and processed using transesterification.

### 2.5.4 Vegetable Oil

Lower quality oil can be used as fuel. Used vegetable oil is increasingly being processed into biodiesel, or (more rarely) cleaned of water and particulates and used as a fuel. Oils and fats can be hydrogenated to give a diesel substitute. The resulting product is a straight chain hydrocarbon with a high cetane number, low in aromatics and sulfur and does not contain oxygen. Hydrogenated oils can be blended with diesel in all proportions. Hydrogenated oils have several advantages over biodiesel, including a good performance at low-temperatures, no storage stability problems and no susceptibility to microbial attack.

### 2.5.5 Biogas

Biogas is produced by the process of anaerobic digestion of organic material by anaerobes. It can be produced either from biodegradable waste materials or by the use of energy crops fed into anaerobic digesters to supplement gas yields. The solid byproduct and digestate can be used as a biofuel or a fertilizer.

### 2.5.6 Bioethers

Bioethers (oxygenated fuels) are cost-effective compounds that act as octane rating enhancers. They also enhance engine performance, whilst significantly reducing engine wear and toxic exhaust emissions. Greatly reducing the amount of ground-level ozone, they contribute to the quality of the air we breathe.

### 2.5.7 Syngas

Biogas is methane produced by the process of anaerobic digestion of organic material by anaerobes. It can be produced either from biodegradable waste materials or by the use of energy crops fed into anaerobic digesters to supplement gas yields. The solid byproduct, digestate, can be used as a biofuel or a fertilizer.

### 2.5.8 Solid Biofuels

Syngas is a mixture of carbon monoxide, hydrogen, and other hydrocarbons and produced by partial combustion of biomass. Before partial combustion, the biomass is dried and sometimes pyrolyzed. The resulting gas mixture, syngas, is more efficient than direct combustion of the original biofuel; more of the energy contained in the fuel is extracted. Solid biofuels are wood, sawdust, grass trimmings, domestic refuse, charcoal, agricultural waste, non-food energy crops, and dried manure. When raw biomass is already in a suitable form, it can burn directly in a stove or furnace to provide heat or raise steam. When raw biomass is in an inconvenient form, the typical process is used to densify the biomass. This process includes grinding the raw

biomass to an appropriate particulate size (known as hogfuel), which depending on the densification type can be from 1 to 3 cm, which is then concentrated into a fuel product. The current types of processes are wood pellet, cube, or puck. The pellet process is most common in Europe and is typically a pure wood product. The other types of densification are larger in size compared to a pellet and are compatible with a broad range of input feedstocks. The resulting densified fuel is easier to transport and feed into thermal generation systems such as boilers.

### **2.5.9 Scope of Second-generation Biofuels**

Second-generation biofuels currently are under development phase. It would use lignocellulosic feedstock such as wood, tall grasses, and forestry and crop residues. This would increase the quantitative potential for biofuel generation per hectare of land and could also improve the fossil energy and greenhouse gas balances of biofuels. The cost of the cellulosic feedstock itself is lower than the first-generation feedstocks. Second-generation feedstocks and biofuels could also offer advantages in terms of reducing greenhouse gas emissions. Currently, the liquid biofuel production based on sugar and starch crops (for ethanol) and oilseed crops (for biodiesel) is generally referred to as first-generation biofuels.

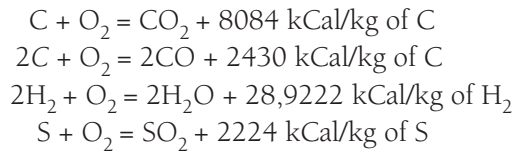
A second-generation biofuels may make it possible to use the lignocellulosic biomass. Cellulosic biomass is more resistant to being broken down than starch, sugar, and oils. The difficulty of converting it into liquid fuels makes it more expensive. The conversion of cellulose to ethanol involves two steps—in the first step, the cellulose and hemicellulose components of the biomass are first broken down into sugars. In the second step, ethanol is obtained after fermentation of sugars. The first step is technically challenging, although research continues on developing efficient and cost-effective ways of carrying out the process.

## **2.6 ► COMBUSTION**

### **2.6.1 Principle of Combustion**

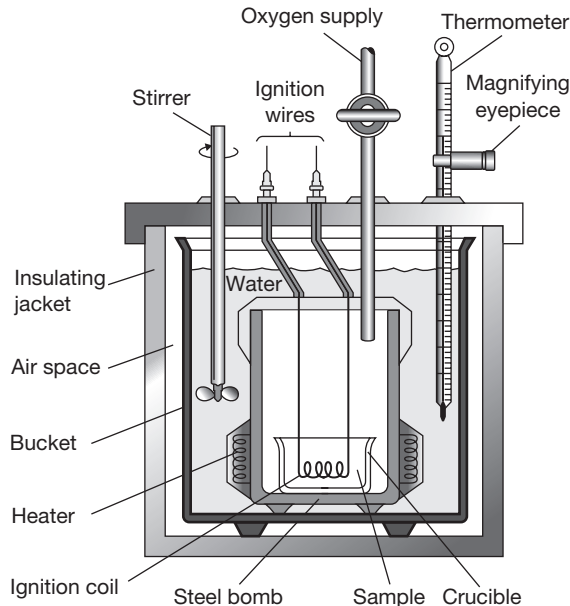
Combustion refers to the rapid oxidation of fuel accompanied by the production of heat or heat and light. Complete combustion of a fuel is possible only in the presence of an adequate supply of oxygen. Oxygen ( $O_2$ ) is one of the most common elements on earth, making up 20.9% of our air. Rapid fuel oxidation results in large amounts of heat. Solid or liquid fuels must be changed to a gas before they will burn. Usually, heat is required to change liquids or solids into gases. Fuel gases will burn in their normal state if enough air is present. The percentage of nitrogen in air is 79%. It is considered to be a temperature reducing dilutant that must be present to obtain the oxygen required for combustion. Nitrogen reduces combustion efficiency by absorbing heat from the combustion of fuels and diluting the flue gases. This reduces the heat available for transfer through the heat exchange surfaces. It also increases the volume of combustion by-products, which then have to travel through

the heat exchanger and up the stack faster to allow the introduction of additional fuel air mixture. This nitrogen also can combine with oxygen (particularly at high flame temperatures) to produce oxides of nitrogen (NO<sub>x</sub>), which are toxic pollutants. Carbon, hydrogen, and sulfur in the fuel combine with oxygen in the air to form carbon dioxide, water vapor, and sulfur dioxide, releasing 8084, 28922, and 2224 kCals of heat, respectively. Under certain conditions, Carbon may also combine with Oxygen to form Carbon Monoxide, which results in the release of a smaller quantity of heat (2430 kCals/kg of carbon) Carbon burned to CO<sub>2</sub> will produce more heat per pound of fuel than when CO or smoke are produced.



## 2.7 ► DETERMINATION OF CALORIFIC VALUE OF FUEL USING BOMB CALORIMETER

A bomb calorimeter is normally used for the determination of the calorific value of solid fuels. However, it can be also used for liquid fuels. The combustion of the fuel takes place at constant volume in a tightly closed vessel as shown in Figure 2.1. The higher calorific value of the fuel is determined at constant volume.



**FIGURE 2.1**

Experimental Set-up of Bomb Calorimeter

The bomb calorimeter consists of strong stainless steel shell, which is known as a bomb. The capacity of the bomb is 650 CC and it can withstand pressure up to 200 atm. Water is filled in the bomb to a specific level. To act as a water seal. In the top cover of the bomb oxygen connection and product release valve is arranged. Bottom cover of the bomb supports an upright, one of them is carrying a ring to support crucible made up of silica and quartz. The uprights are provided through the bottom with two insulating firing plugs through which the leads from the main supply are taken via a rheostat. During the test, the bomb is placed in a copper calorimeter containing 2500 CC of water that is agitated by a stirrer run by a motor.

The Calorimeter is surrounded by an outer walled vessel with water jacket and air space between these two containers reduces the radiation loss. The thermometer used to read up to 1/100 degree centigrade at total range is 5°C.

The fuel is placed in the crucible. The bomb is then connected to oxygen cylinder and pressure is adjusted to about 25 to 30 atm. Water in the container is continuously stirred and the temperature is noted up to steady state. Now stirring is stopped. The fuse wire ignites the fuel in the presence of oxygen. The temperature of water starts rising. At certain intervals (10 sec.) temperature is noted up to maximum temperature and after each ½ minute decreasing temperature.

$$\text{True temperature rise, } (\Delta\theta) = \frac{r_c}{2} \times t + \text{Recorded temperature rise}$$

where  $r_c$  is maximum temperature reached.

Let  $C$  is calorific value of the fuel burnt

$C_1$  is calorific value of wire burnt

$W$  is mass of water contained in calorimeter

$w$  is water equivalent of calorimeter

$x$  is quantity of fuel burnt

$x_w$  is quantity of wire burnt

$\theta_1$  is steady temperature before combustion

$\theta_2$  is max temperature after combustion

$t$  is time elapsed for reaching maximum temperature

$$q_m = \theta_2 - \theta_1 \text{ and true temperature rise, } \Delta\theta = \theta_m + \frac{r_c}{2} \times t$$

$$C \cdot x + C_1 \cdot x_w = (W + w) \left( \theta_m + \frac{r_c}{2} \times t \right)$$

$$C = \frac{(W + w) \left( \theta_m + \frac{r_c}{2} \times t \right) - C_1 \cdot x_w}{x}$$

**EXAMPLE 2.1**

A 1g sample of fuel is burned in a bomb calorimeter containing 1.2 kg of water at an initial temperature of 25°C. After the reaction, the final temperature of the water is 33.2°C. The heat capacity of the calorimeter is 837 J/°C. The specific heat of water is 4.184 J/g°C. Calculate the heat of combustion of the fuel in kJ/mol.

**SOLUTION**

Heat gained by water and calorimeter =  $W \cdot S_w \cdot \Delta\theta + w \cdot S_c \cdot \Delta\theta = 1200\text{g} \times 4.18 \text{ J/g}^\circ\text{C} \times (33.2^\circ\text{C} - 25^\circ\text{C}) + 837 \text{ J/g}^\circ\text{C} \times (33.2^\circ\text{C} - 25^\circ\text{C}) = 47994.6\text{J} = 47.994 \text{ kJ}$

Heat released by fuel = Heat gained by water and calorimeter

$Q = 47.994 \text{ kJ/g} = 47.994 \text{ kJ/g}$

**RECAP ZONE** .....**Points to Remember**

- Any material that can be burned to release thermal energy is called a **fuel**.
- **Fossil fuels** originate from the earth as a result of the slow decomposition and chemical conversion of organic material.
- **Coal** is classified into three major classes—anthracite, bituminous, and lignite.
- There are two methods for coal analysis: ultimate and proximate analysis. The ultimate analysis determines all solid or gaseous coal components, and the proximate analysis determines only the percentage of carbon, volatile matter, moisture, and ash. The ultimate analysis indicates the various chemical constituents such as carbon, hydrogen, oxygen, sulfur, etc.
- The major source of liquid fuels is crude petroleum; other sources are shale and tar sands.
- Synthetic hydrocarbon fuels such as gasoline and methanol can be made from coal and natural gas. Ethanol, some of which is used as an automotive fuel, is derived from vegetable matter.
- **Kerosene** and **diesel** are refined petroleum distillate consisting of a homogeneous mixture of hydrocarbons.
- **Gasoline**, or **petrol**, is made of a mixture of hydrocarbons, which are molecules composed of carbon and hydrogen atoms. Typically, in standard gasoline, the hydrocarbons consist of carbon chains are 5-10 carbon atoms long.
- The **calorific value** is the measurement of heat or energy produced and is measured in terms of gross calorific value or net calorific value.
- Gaseous fuels in common use are liquefied petroleum gases (**LPG**), natural gas, producer gas, blast furnace gas, coke oven gas, etc. LPG is a predominant mixture of propane and Butane with a small percentage of unsaturates (Propylene and Butylene) and some lighter  $C_2$  as well as heavier  $C_5$  fractions.

- **Biofuels** include fuels derived from biomass conversion, as well as solid biomass, liquid fuels, and various biogases.
- **Bioethanol** is an alcohol made by fermentation of carbohydrates produced in sugar or starch crops such as corn or sugarcane.
- **Biodiesel** is made from vegetable oils and animal fats.
- **Bioalcohols** are produced by the action of microorganisms and enzymes through the fermentation of sugars or starches or cellulose.
- Green diesel, also known as renewable diesel, is a form of diesel fuel, which is derived from renewable feedstock rather than the fossil feedstock used in most diesel fuels.
- **Bioethers** (oxygenated fuels) are cost-effective compounds that act as octane rating enhancers.
- **Biogas** is methane produced by the process of anaerobic digestion of organic material by anaerobes.
- **Syngas** is a mixture of carbon monoxide, hydrogen, and other hydrocarbons and produced by partial combustion of biomass.
- Solid biofuels are wood, sawdust, grass trimmings, domestic refuse, charcoal, agricultural waste, non-food energy crops, and dried manure.
- Combustion refers to the rapid oxidation of fuel accompanied by the production of heat or heat and light.
- Bomb calorimeter is normally used for the determination of the calorific value of solid fuels. However, it can be also used for liquid fuels.

### Important Formulae

$$C = \frac{(W + w) \left( \theta_m + \frac{r_c}{2} \times t \right) - C_1 \cdot x_w}{x}$$



## REVIEW ZONE .....

### Multiple-choice Questions

1. Which of the following is not a fossil fuel?
  - (a) Oil
  - (b) Natural gas
  - (c) Geothermal
  - (d) Coal
2. The total amount of heat or energy produced by 1 kg of fuel is the:
  - (a) Heat content
  - (b) Net Calorific Value (NCV)
  - (c) Gross Calorific Value (GCV)
  - (d) Specific heat
3. Moisture, ash content, volatile matter and fixed carbon are measured for coal as part of:
  - (a) Proximate analysis
  - (b) Proximate and ultimate analysis
  - (c) Ultimate analysis
  - (d) None of the above
4. What is the percentage of oxygen by volume in the atmosphere?
 

(a) 14%	(b) 23%
(c) 20.9%	(d) 79%

5. LPG is predominantly a mixture of propane and:  
(a) Methane (b) Isopropane  
(c) Butane (d) Ethane
6. Combustion of which of the following fuels requires the highest amount of excess air:  
(a) Light diesel oil (LDO)  
(b) Natural gas  
(c) LPG  
(d) Coal
7. The presence of carbon monoxide (CO) in flue gases means:  
(a) High excess air  
(b) Poor combustion  
(c) High thermal efficiency  
(d) All of the above
8. The complete combustion of  $C_2H_4$  in air yields:  
(a)  $C_2H_4$  and  $H_2$   
(b) CO and  $H_2O$   
(c)  $CO_2$  and  $H_2O$   
(d) C and  $H_2$
9. Which fuels are used for running automobiles?  
(a) Wood (b) Coal  
(c) Diesel (d) Charcoal
10. Charcoal burns in air, producing:  
(a)  $CO_2$  (b) CO  
(c)  $H_2$  (d)  $O_2$
11. Combustion is a reaction in which a Substance reacts with:  
(a) Hydrogen (b) Nitrogen  
(c) Oxygen (d) Chlorine
12. Fuel may be:  
(a) Solid (b) Liquid  
(c) Gas (d) All of these
13. Combustion is a:  
(a) Physical process  
(b) Chemical process  
(c) Both (a) and (b)  
(d) None of these
14. Fire extinguisher:  
(a) Cut off the supply of air  
(b) Bring down the temperature of fuel  
(c) Both (a) and (b)  
(d) None of these
15. For combustion \_\_\_\_ is necessary:  
(a) Air (b) Water  
(c) Paper (d) Fuel
16. Good fuel is:  
(a) Readily available  
(b) Cheap  
(c) Burn easily in air  
(d) All of these
17. Which is better domestic fuel?  
(a) CNG (b) LPG  
(c) Wood (d) Coal
18. Use of \_\_\_\_ in vehicle reduces pollution:  
(a) Petrol (b) Diesel  
(c) CNG (d) None of these
19. Ideal fuel has \_\_\_\_ calorific value:  
(a) Low (b) High  
(c) Moderate (d) Zero
20. Calorific value is measured in:  
(a) Kilo Joule  
(b) Kilograms  
(c) Kilo Joule per Kg  
(d) Kilometre
21. Incomplete combustion gives:  
(a)  $CO_2$  (b) CO  
(c) Carbon (d) None of these

## Answers

- |         |         |         |         |         |         |
|---------|---------|---------|---------|---------|---------|
| 1. (c)  | 2. (b)  | 3. (a)  | 4. (c)  | 5. (c)  | 6. (d)  |
| 7. (b)  | 8. (c)  | 9. (c)  | 10. (a) | 11. (c) | 12. (d) |
| 13. (b) | 14. (c) | 15. (a) | 16. (d) | 17. (b) | 18. (c) |
| 19. (b) | 20. (c) | 21. (b) |         |         |         |



## Theory Questions

---

1. Discuss the use of fuels and their classifications.
- \*2. Write a short note on Global Warming.
- \*3. Give detailed classification of fuel.
4. Write notes of proximate and ultimate analysis of coal.
- \*5. What are LPG and CNG?
6. Write the various types of coals available for combustion and mention their properties.
7. Write short notes on major petroleum products such as diesel and kerosene.
8. What are the major contents of liquid fuels? Explain in detail.
9. Explain the properties and use of LPG, and natural gas.
- \*10. What do you mean by calorific value? Explain the experimental setup to measure the calorific value of a liquid fuel.
11. State the advantages of gaseous fuels over solid and liquid fuels.
- \*12. List various liquid fuels. State their merits over solid fuels.
- \*13. Write a short-note on bio-fuels.

## Numerical Problems

---

1. A 1 g sample of fuel is burned in a bomb calorimeter containing 1 kg of water at an initial temperature of  $20^{\circ}\text{C}$ . After the reaction, the final temperature of the water is  $30^{\circ}\text{C}$ . The heat capacity of the calorimeter is  $837 \text{ J}^{\circ}\text{C}$ . The specific heat of water is  $4.184 \text{ J/g}^{\circ}\text{C}$ . Calculate the heat of combustion of the fuel in  $\text{kJ/mol}$ .

---

\* indicates that similar questions have appeared in various university examinations.

# Power Plant Engineering and Sources of Energy

## Learning Objectives

*By the end of this chapter, the student will be able:*

- To understand the conventional and nonconventional forms of energy
- To demonstrate the method of conversion of different forms of energy into electricity
- To differentiate the renewable and non-renewable forms of energy

### 3.1 ► INTRODUCTION

There are different forms of energy; all the energy cannot be used as a work. The convertibility of energy into work depends on its availability. In this chapter, we will discuss about the conversion of energy from one form to another and various sources of energy. The principles of operations of various types of power plant have been discussed such as thermal power plant, hydroelectric power plant, and nuclear power plant. Also, the different sources of the renewable and non-renewable form of energy have been introduced. The main application of power plant is to produce electrical power from other sources of energy such as coal, water, diesel, kerosene oil, gasoline, nuclear materials, tidal power, wind energy, geothermal energy, etc.

### 3.2 ► PRIME MOVERS

The prime mover is a primary source of power. All the machinery that provides power for performing various kinds of mechanical work is prime movers. It is a group of machines that transform various forms of energy such as thermal, electrical, or pressure into mechanical form. Engines, turbines, pumps, actuators, etc. are the examples of prime movers.

On the basis of the direction of movement, prime movers may be classified as *reciprocating prime movers* and *rotating prime movers*. Steam engine, reciprocating pump, reciprocating compressors, internal combustion engines, mechanical actuators, etc. are the example of reciprocating prime movers and centrifugal pump, gas turbines, steam turbines, rotary compressors, etc. are the examples of rotating prime movers.

### 3.2.1 Historical Development of Prime Movers

- ▶ The revolution was begun when the technology of the steam engine was invented by James Watt.
- ▶ For power generation, three principal competitors are introduced in the field of production of mechanical power. They are the steam turbine plant, the diesel piston engine, and the gasoline piston engine.
- ▶ Steam turbines became the most important prime mover for power generation in the nineteenth century.
- ▶ Because of this, new bulky and expensive steam generating equipment, the boiler and the nuclear reactor, were introduced. They are intended to produce steam as an intermediate working fluid.
- ▶ Later, many other power generation systems were introduced. The example of such types of power generators is diesel plant. In many locations, these machines started replacing bulky power plants for power generation.
- ▶ Gasoline engines were used in the early days for aircraft propulsion. A device named the gas turbine was also introduced during that time, and it supplanted the use of superchargers based on piston engines.
- ▶ The main development of the gas turbine started only after the World War II. They were based on shaft power technology and were called turboprops. After some time the development of turbojet engines for aircraft usage started, and these are based on the mass airflow rather than shaft output.

## 3.3 ► POWER PLANT ENGINEERING

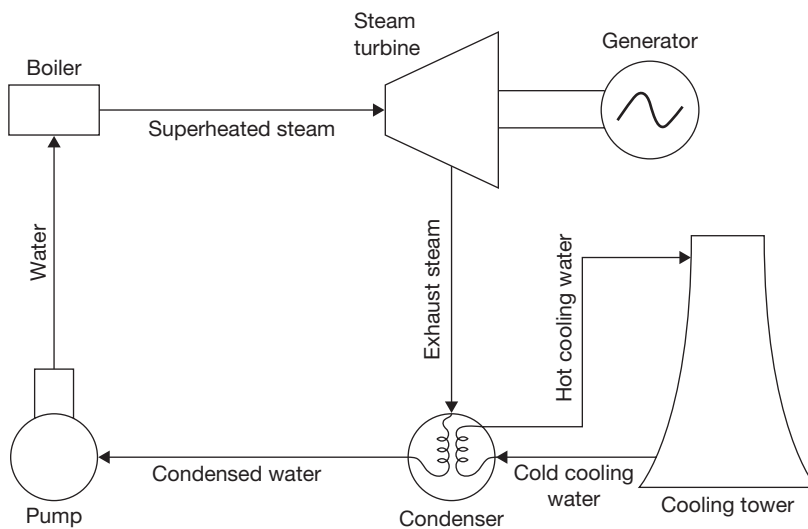
Power plant engineering is a branch of engineering which deals with the conversion of various forms of energy into electrical energy. In this text, we will discuss about thermal power, hydroelectric power, nuclear power, and non-conventional sources of energy. In a thermal power plant, coal, diesel, petrol, natural gas, and kerosene oil are used as fuel and chemical energy of these fuels is converted into mechanical energy and then mechanical energy into electrical energy. In a hydroelectric power plant, the potential energy of water is converted into mechanical energy as shaft power and then mechanical energy into electrical energy. Similarly, in the case of nuclear energy, nuclear power is used to generate the heat required

to produce superheated steam and then the heat energy is converted into mechanical energy and the mechanical energy is converted into electrical energy.

### 3.3.1 Thermal Power Plant

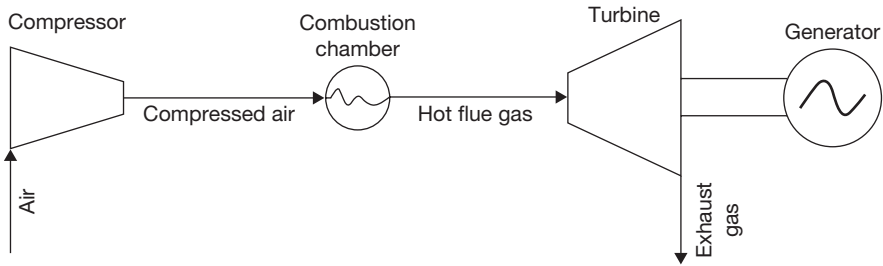
Thermal power plants may be coal based or gas based. In coal based power plant coal is used as burning fuel and the heat energy is transferred to water to convert it into superheated steam. The heat energy of the steam is converted into shaft power through the expansion of steam in a steam turbine. The shaft of the steam turbine is coupled to a generator where electricity is generated. The exhaust steam from steam turbine is condensed in condenser using cooling water. Condenser works just like a heat exchanger where heat energy of steam is transferred to cooling water and steam is condensed in the form of water, which is then pumped into the boiler. The cooling water is recirculated through a cooling tower to release the heat. A self-explanatory diagram is shown in Figure 3.1. The detail working of boilers and steam turbines are discussed in detail in Chapter 4 and 5, respectively.

In gas based power plant or gas power plant, air is compressed to high pressure and heat energy is added to compressed air using combustion chamber by direct burning of fuel in compressed air or indirect heat transfer to the compressed air. The high pressure and high-temperature air is expanded inside the gas turbine, which is coupled to a generator that generates electricity due to shaft rotation. The exhaust gas from the turbine is released into



**FIGURE 3.1**

A Block Diagram of Thermal Power Plant

**FIGURE 3.2**

A Block Diagram of Gas Power Plant

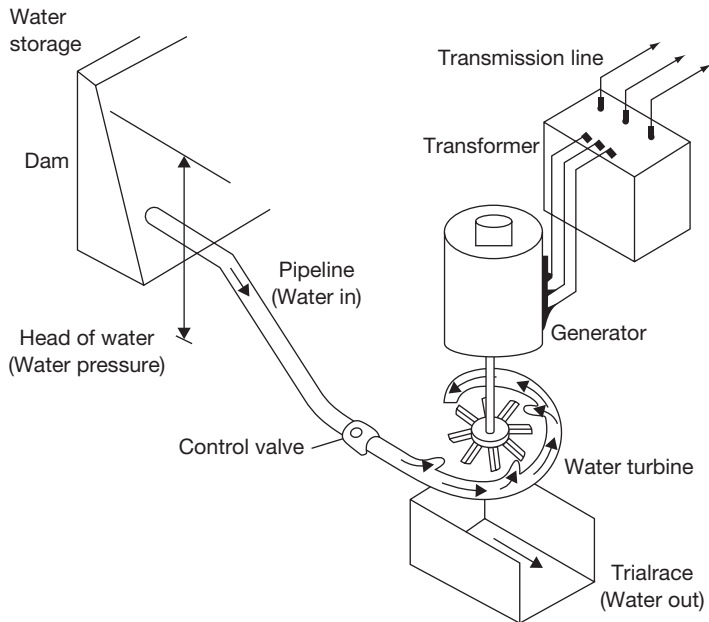
the atmosphere in the case of the open cycle gas turbine and re-circulated to the compressor in the case of closed cycle gas turbine. The self explanatory diagram of the gas power plant is shown in Figure 3.2. The detail discussion about gas turbine and compressor are given in Chapters 5 and 10, respectively.

### 3.3.2 Hydroelectric Power Plant

The principle of electricity generation in the case of hydroelectric power plant is same as in thermal power plant only difference is that the shaft power to the turbine is provided by pressure and kinetic energy of water in the case of hydroelectric power plant; but in thermal power plant the shaft power to the turbine is provided by heat energy of superheated steam or gas. As shown in Figure 3.3, the potential energy of water stored in a dam is used to rotate the turbine blades mounted on a shaft coupled to a generator. Different types of turbines may be used in a hydroelectric power plant depends on the availability of water heads. The applicability of different types of water turbine for various water heads and their specific speeds are discussed in detail in Chapter 9.

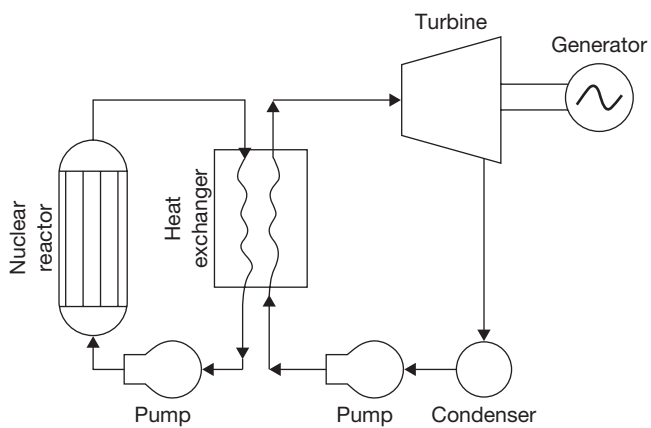
### 3.3.3 Nuclear Power Plant

In a nuclear power plant, the nuclear energy released from radioactive materials due to fission reaction is utilized to heat the water and convert it into superheated steam. The rest of the electricity generation process is similar to the steam power plant as discussed in section 1.3. The main problem is the careful handling of radioactive fuel used in a nuclear reactor. Radiations from nuclear fuel are very harmful and dangerous for human beings. Therefore, complete shielding of a nuclear reactor is required. After a useful life of nuclear fuel, disposal of nuclear waste is the second major problem with nuclear power plant. The installation cost of nuclear power plant is very high, but the operational cost and production cost per unit of electricity is very economical. A self-explanatory block diagram of nuclear power plant is shown in Figure 3.4.



**FIGURE 3.3**

A Block Diagram of Hydroelectric Power Generation



**FIGURE 3.4**

A Block Diagram for Nuclear Power Plant

### Components of Nuclear Reactor

**Fuel:**  ${}_{92}\text{U}^{235}$ ,  ${}_{94}\text{Pu}^{239}$ ,  ${}_{92}\text{U}^{233}$  are nuclear fuel used in a nuclear reactor to release the heat energy. In Uranium ore,  ${}_{92}\text{U}^{235}$  is available only up to 0.7% remaining is  ${}_{92}\text{U}^{238}$ . The other two fuels  ${}_{94}\text{Pu}^{239}$  and  ${}_{92}\text{U}^{233}$  are formed in the reactor during the fission process of  ${}_{92}\text{U}^{235}$ .  ${}_{90}\text{Th}^{232}$  is formed due to absorption of a neutron by  ${}_{92}\text{U}^{235}$  without fission. In homogeneous reactors, the fuel (Uranium) and moderator (Carbon) are mixed uniformly and used in the form of rods or plates in the reactor. In heterogeneous reactors, fuel is used in the form of rod and moderator surrounds it. The fuel rod is clad with aluminum, stainless steel, or zirconium to prevent from oxidation.

**Moderator:** The moderator is a material which is used to reduce the kinetic energy of fast neutron (1MeV or 13200 km/sec to 0.25 eV or 2200 m/sec) within a fraction of a second to maintain the fission chain reaction.  $\text{H}_2$ ,  $\text{D}_2$ ,  $\text{N}_2$ , C, Heavy water, Be, are some important moderators. The ordinary water is used as a moderator only with enriched uranium (Enrichment is a process to increase the amount of  ${}_{92}\text{U}^{235}$ ) whereas graphite, heavy-water, Beryllium can be used with natural uranium. The major characteristics of moderators are the ability to slow down neutrons, resistant to corrosion, high melting point, high chemical stability, and non-absorbent of neutrons.

**Control Rod:** The function of the control rod is to start the nuclear chain reaction when the reactor is started from cold, to maintain the chain reaction at steady state condition, and to shut down the reactor automatically under an emergency condition. The materials used for control rods must have very high absorption capacity for neutrons. The common materials used for control rods are cadmium, boron, or hafnium.

**Shielding:** Neutrons, gamma rays, and all other radiations are efficiently absorbed by the concrete and steel. The inner lining of the core is made of 50 to 60 cm thick steel plate and it is further thickened by a few meters of concrete. The lining of steel plate absorbs these neutrons and becomes heated, but prevent the adjacent wall of the reactor vessel from becoming heated. The thermal shield is cooled by circulating water.

**Reactor Vessel:** It consists of the reactor core, reflector, and shield. It also provides the entrance and exit passage for directing the flow of the coolant. It should have withstanding capacity of more than 200 bars. At the top of the vessel, a hole is provided to insert the control rods. The reactor core is generally placed at the bottom of the vessel.

### Different Types of Nuclear Reactors

The nuclear reactors can be classified on the basis of neutron energy, fuel used, moderator used, and coolant used. On the basis of neutron energy, we can classify the nuclear reactor as Fast reactor and thermal reactor; on the basis of fuel used, we can classify them as a natural fuel reactor and enriched uranium reactor; on the basis of moderator, we can

classify them as water moderated, heavy water moderated, graphite moderated, and beryllium moderated; on the basis of coolant, we can classify them as water cooled reactor, gas cooled reactor.

**Pressurized Water Reactor (PWR):** Fuel used in this reactor is enriched uranium (Uranium Oxide). Uranium oxide is highly resistant to irradiation damage and is very well adapted to high burn up. It is also highly resistant to corrosion by high-pressure water in the event of break-up in the fuel cladding. The water becomes radioactive during passing from the reactor. Therefore, the entire primary circuit including steam generator must be shielded to protect the operating people. The radioactive coolant does not make the steam radioactive in the boiler.

**Boiling Water Reactor (BWR):** In this reactor, enriched uranium is used as fuel and water is used as a coolant and moderator like PWR except the steam is generated in the reactor itself.

**Heavy Water Cooled and Moderated CANDU (Canadian Deuterium Uranium) Reactor:** In this reactor, natural uranium is used as fuel and heavy water is used as a coolant and moderator. The heavy water is passed through the pressure tubes in the reactor and heat exchanger in the primary circuit in the same way as in a PWR and the steam is raised in the secondary circuit. Heat is transferred from heavy water to ordinary water in the heat exchanger. The control of the reactor is achieved by the level of the moderator, i.e., heavy water in the reactor. Therefore, the control rod is not required in this reactor.

**Gas Cooled Reactor (GCR):** The reactor is cooled by the gas and the heat carried away by the gas from the reactor is either used for generating steam in the secondary circuit like PWR or it can be directly used in a gas turbine.

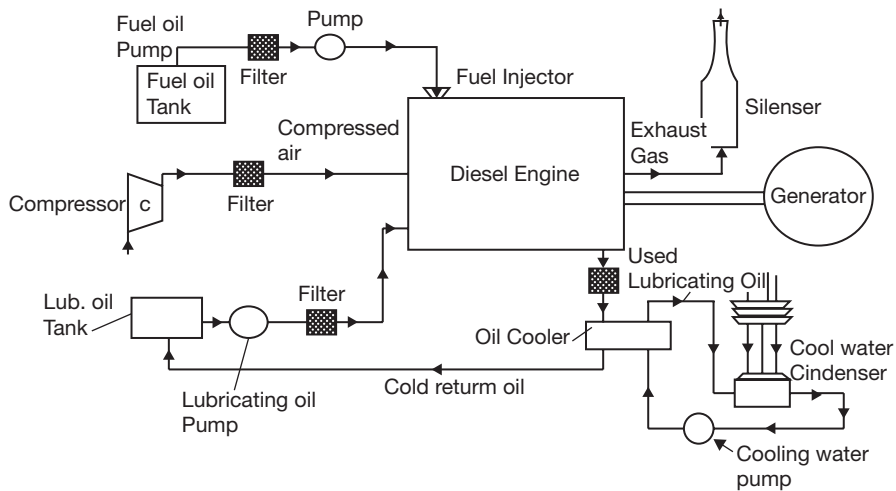
**Liquid Metal Cooled Reactor:** The excellent heat transfer capacity of molten metals makes them attractive as reactor coolant. The liquid metal coolant is circulated through the reactor at moderate pressure and high-temperature ( $540^{\circ}\text{C}$ ). In this reactor enriched uranium is used as fuel and graphite as moderator. The common metals which can be used as coolant may be sodium, potassium, etc. Sodium is most suitable coolant as it has low absorption, low melting point, high boiling point, high specific heat, high thermal conductivity and considerably cheaper in cost.

**Fast Breeder Reactor (FBR):** In a fast breeder reactor, enriched uranium or plutonium is kept in a casing without a moderator. The casing is covered with a thick blanket of depleted fertile uranium. The ejected excess of neutrons is absorbed by the fertile blanket and it converts into fissile material. The heat produced in the reactor core is carried away by liquid metal. The major difficulty is to remove the large quantity of heat from the core as the power density is very high (430 kW) per liter of core volume, which is 40 times greater than a CANDU type reactor, 13 times greater than BWR, and 20 times greater than a gas cooled reactor.



### 3.3.4 Diesel Power Plant

The diesel power plant produces mechanical power based on the principle of diesel engines as shown in Figure 3.5. The generator is coupled with the diesel engine and the mechanical power or the shaft power produced by the diesel engine is converted into electrical power with the help of a generator. This is used in combination of the thermal power plant or the hydraulic power plant to meet the requirement of power during the peak load or power failure due to some unavoidable circumstances. The diesel power plant can be divided into two classes—stationary and mobile. A stationary diesel power plant generally uses four-stroke diesel engines and less frequently uses two-stroke diesel engines, with power ratings of 110, 220, 330, 440, and 735 kilowatts (kW). The stationary diesel power plant may be used for more than 750 kW ratings and this may go up to 2200 kW ratings. The main advantages of the diesel power plant are an economy of operation, stable operating characteristics, and easy and quick start-up. The main disadvantage of the diesel power plant is comparatively short intervals between major overhauls. The efficiency of the diesel power plant can be increased by utilizing the major part of the waste heat for preheating the air and fuel. The stationary diesel power plant is used where construction of thermal power plant or the hydroelectric power plant is difficult. Mobile diesel power plant is generally used for the agriculture, forestry, and for the special occasion where the power supply is not available.



**FIGURE 3.5**

A Schematic Diagram of Diesel Power Plant

**Working Principle of the Diesel Power Plant:** In the diesel engine power plant, the fuel mixture and air are used as a working medium. During suction stroke, atmospheric air enters the combustion chamber. With the help of the injection pump fuel is injected into the chamber at the end of compression stroke. Inside the engine, the air and the fuel are mixed and the charge is ignited because of the compression present inside the cylinder. The main principle observed in the diesel engine is the thermal energy, it must be converted into the mechanical energy and further, the mechanical energy must be converted into the electrical energy. The main purpose is to develop electricity with the help of the alternator or generator.

**Applications of the Diesel Engine Power Plant During Peak Load:** During the peak load, the diesel power plant is used to supply the extra power required quickly and then stopped after the peak hours.

**Mobile Plant:** Diesel plants can be tied on trailers and can be traveled for emergency or temporary purposes.

**Standby Unit:** If it cannot handle up with the demand or main unit fails, then the diesel plant can supply the required power source.

**Emergency Plant:** During the time of power disruption in a diesel electric plant, the emergency plant can be used to generate the power. *Starting stations:* The diesel station may be used to run the induced draft fans, forced draft fans. Boiler feed is required for the larger steam power plants.

### **Advantages of Diesel Power Plant**

- ▶ Low capital cost.
- ▶ Simple design and easy installation of the plant.
- ▶ Availability in the standard capability.
- ▶ Requirement of less space in comparison to the other plants.
- ▶ Quick start and stop facility.
- ▶ Requirement of less amount of cooling.
- ▶ Higher part loads efficiency.
- ▶ Requirement of less number of engineers.
- ▶ No ash handling problems.

### **Disadvantages of Diesel Power Plant**

- ▶ High operating cost.
- ▶ High lubrication and maintenance cost.

- ▶ Limited capacity.
- ▶ Sound pollution.
- ▶ No overloading.
- ▶ Released unwanted emissions.
- ▶ Limited life time of 7 to 10 years.

### 3.3.5 Tidal Power Plant

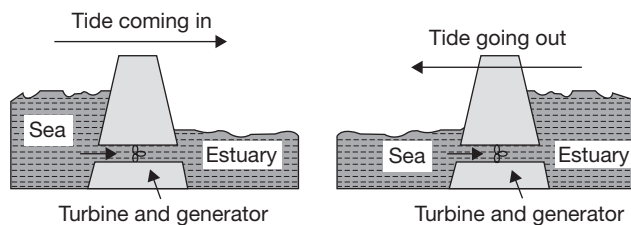
Tidal energy is harnessed from the tides of the ocean in the form of the natural ebb and flow of the tides. Tides are created by the gravitational interaction of the moon and sun with the earth rotation. It can be harnessed both in the sea, tidal rivers, and estuaries. On some shorelines, water levels can go up to 8-12 m. Due to drastic changes in water level, the first type of tidal energy, i.e., tidal barrages as shown in Figure 3.6 can be used. Tides can occur once or twice a day depending on location. The timing of the tides fluctuates over a period of two weeks or so.

The tidal energy can be harnessed in mainly in three ways:

- (a) Tidal barrage
- (b) Tidal turbines
- (c) Tidal fence

#### *Tidal Barrage*

A Tidal barrage is very similar to conventional hydroelectric power generation. In this method, the tidal estuary is blocked off with a dam or barrage. Movable flood gates (called sluice gates) on the dam allow incoming tidal waters to fill up in a reservoir. Once the water reaches its maximum level, the gates close and trap the water as shown in Figure 3.6. The head of the water in the artificial estuary is called a hydrostatic head. When the high head water returns, it rotates the turbine blade mounted on a shaft, which is coupled to the generator. The generator generates the electricity using the mechanical power of the turbine shaft.

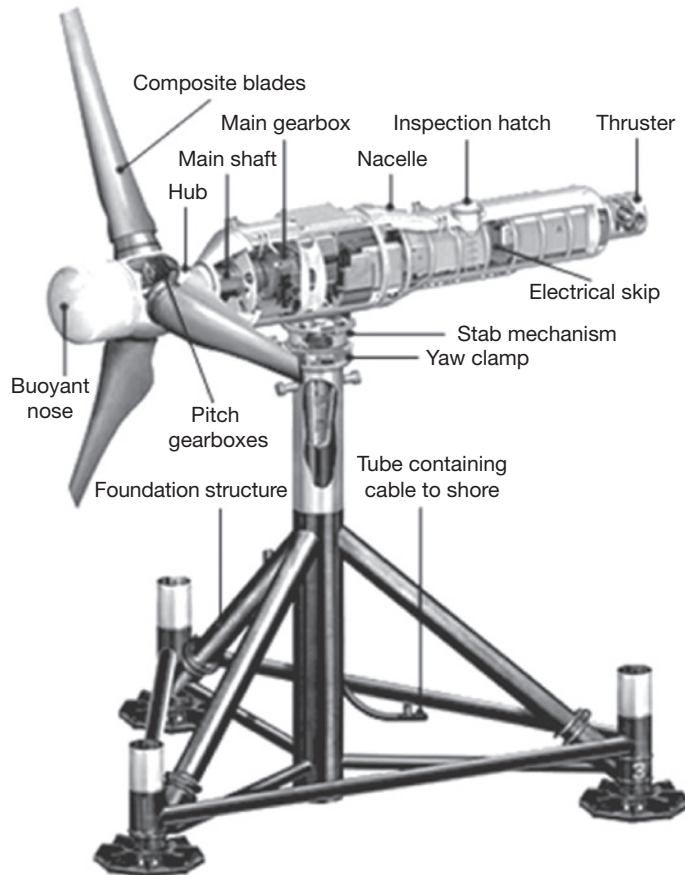


**FIGURE 3.6**

Tidal Barrage

### Tidal Turbine

The tidal turbine is another way to exploit tidal power. Tidal turbines are submersible wind turbines that use water instead of air to turn the blades. Tidal turbines are deep-set 20–30 m and can be situated at the place of strong tidal flow. Because of the heavier density of water as compared to air, tidal turbines must be built much sturdier than their terrestrial counterparts as shown in Figure 3.7. Submerged turbines help to reduce the structural strain. The advantage of the greater density of water is that relatively large amounts of power can be produced with relatively small current and rotor diameter. A rotor with a diameter of 10–15 m can generate 200–700 kW of power, whereas the same power is generated by the wind turbine with a rotor diameter of 45 meters. Tidal turbines function best at flow rates of 7–11 km/hr. The main advantage of tidal turbines, in contrast with wind turbines, is their predictability. Tides flow in and out every day, promising daily energy.



**FIGURE 3.7**

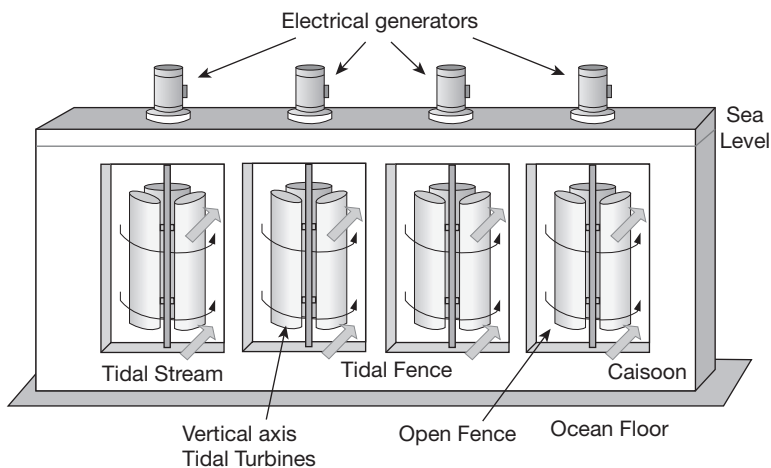
Tidal Turbine

### Tidal Fences

Tidal fence is an extension of tidal turbine technology. A series of turbines are positioned in a row as a “fence” through which water passes as shown in Figure 3.8. Tidal fences are constructed in channels between two land masses. The energy potential depends largely on the rate of flow, which is unique for each location. It has been observed that little power is generated when only a few turbines are installed, whereas too many obstructions to the flow also limit the power potential. Therefore, it is important to determine the optimum number of turbines, as well as their optimum location. Fence installations are presumed to be less expensive to develop than tidal barrages, as well as less impacting on the environment.

### Advantages of Tidal Power

- ▶ Once the tidal power plant is constructed, tidal power is free.
- ▶ No greenhouse gases or other wastes are produced.
- ▶ No fuel is required.
- ▶ Maintenance is less costly.
- ▶ Tides are totally predictable.



**FIGURE 3.8**

Tidal Fences

### Disadvantages of Tidal Power

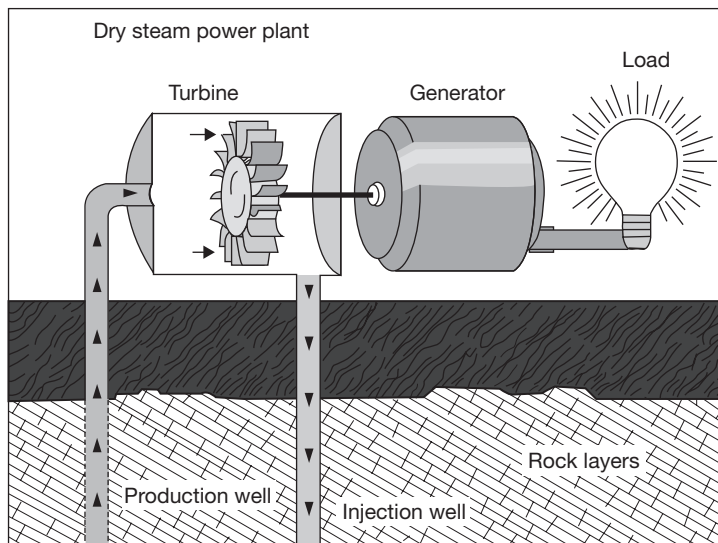
- ▶ A barrage across an estuary is very expensive to build.
- ▶ The barrage affects a very wide area.
- ▶ The environment is changed for many miles upstream and downstream of the barrage.
- ▶ Only provides power for around 10 h each day, when the tide is actually moving in or out.
- ▶ There are few suitable sites for tidal barrages.

### 3.3.6 The Geothermal Power Plant

A thermal power plant needs steam to generate electricity. The steam rotates the turbine that is coupled with a generator, which produces electricity. The geothermal power plant also works on the same principle, but steam is produced without heating the water from coal, diesel, or nuclear reaction; however, uses steam produced from reservoirs of hot water found a couple of miles or more below the Earth's surface. There are three types of geothermal power plant—dry steam, flash steam, and binary cycle.

#### Dry Steam Power Plant

The dry steam power plant draws from underground resources of steam. The steam is piped directly from underground wells to the power plant, where it is directed into a turbine/generator unit as shown in Figure 3.9. The rest of the power production process is same



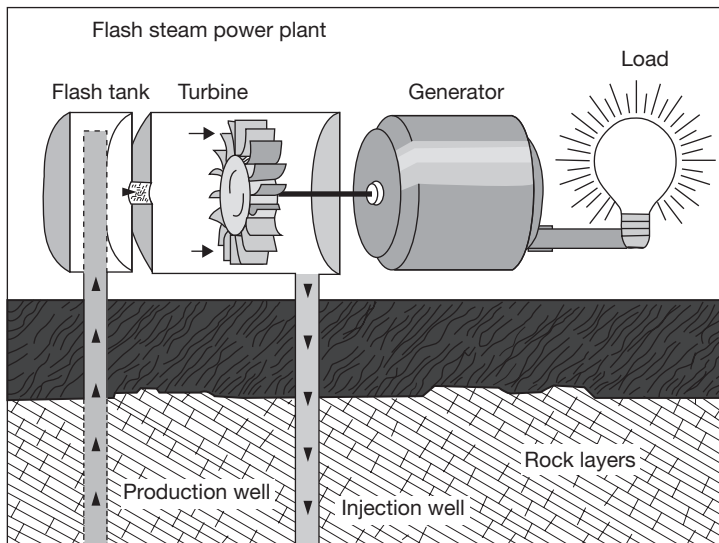
**FIGURE 3.9**

Dry Steam Power Plant

as in the case of thermal power plant. The Geysers is one of the dry steam power plants in northern California.

### Flash Steam Power Plant

Flash steam power plants are the most common among the geothermal power plants as shown in Figure 3.10. They use geothermal reservoirs of water with temperatures greater than  $182^{\circ}\text{C}$ . This hot water flows up through wells in the ground under due to its own pressure. As it flows upward, the pressure decreases and some of the hot water boils into steam. The steam is then separated out from the water and used to rotate the blades of the turbine, which is coupled to a generator to produce electricity. The separated water and condensed steam are injected back into the reservoir, making this a sustainable resource by recycling the water.

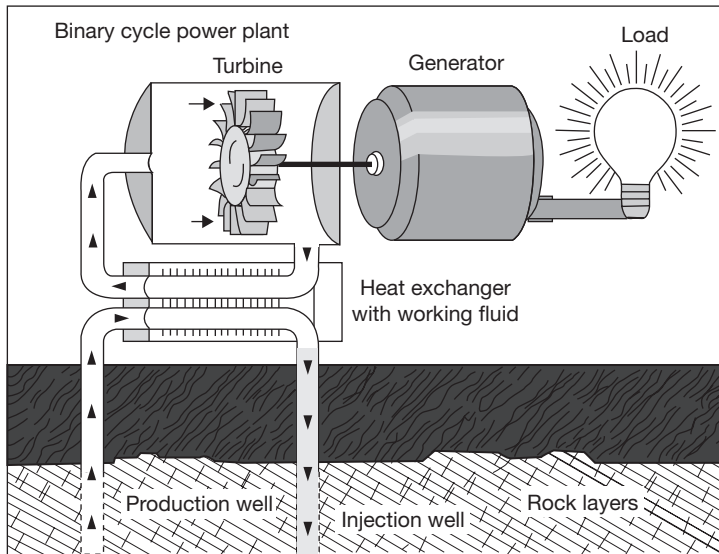


**FIGURE 3.10**

Flash Steam Power Plant

### Binary Cycle Power Plants

Binary cycle power plants operate on water at lower temperatures of about  $107\text{--}182^{\circ}\text{C}$ . The heat of the hot water, i.e., underground water is used to heat/boil a *working fluid*, usually an organic compound with a low boiling point. The working fluid is vaporized in a *heat exchanger* and used to rotate a turbine as shown in Figure 3.11. The water is then injected back into the ground to be reheated. The water and the working fluid are kept separated during the whole process, so there are little or no air emissions. There are two cycles—one cycle is of ground hot water and another is of the working fluid. Thus, this is



**FIGURE 3.11**

Binary Cycle Power Plants

known as Binary cycle power plant. Many geothermal reservoirs are located in the western states, Alaska, and Hawaii in the United States.

### 3.3.7 Windmill

Winds are produced due to uneven heating of the earth's surface by the sun, the rotation of the earth and the irregularities of the earth's surface. Wind flow patterns vary from place to place and are affected by bodies of water, vegetation, and differences in terrain. Wind is nothing more than the movement of air from one place to another. Windmill harnesses the wind speed into power generation using a generator. The wind rotated the blades mounted on the hub/propeller of a rotor. The rotor is coupled to the generator, which converts the mechanical power of the rotor into electrical power. Figure 3.12 shows the installed windmills in a coastal area.

**Main Components of the Windmill:** Major components of the windmill are blades, rotor, gearbox, anemometer, and tower. A gearbox is used to maintain the speed of the shaft constant. Fixed speed windmills run at one speed no matter what the speed of wind is and use the gearbox (gearbox has gears which convert the slow speed of the spinning blades into higher-speed rotary motion) to generate electricity at the right frequency for the grid whereas variable speed windmills speed up and down as the wind speeds up and down.





**FIGURE 3.12**

Windmill

In coastal areas where land and water meet, the phenomenon of wind can be observed. Water usually does not heat or cool as quickly as land. During the day, the air above the land heats up more quickly than the air above the water. The warm air over the land expands, becomes less dense, and rises. The heavier, denser, cool air over the water flows in to take its place, creating the wind. Similarly, the atmospheric winds that circle the Earth are created because the land near the equator is heated more by the sun than the land near the North and South Poles.

Windmill converts the wind's kinetic energy into electrical energy with the help of blades and generator. The wind flows over the airfoil-shaped blades, creating lift and causing them to rotate and in the process, the wind slows down. The blades are connected to a shaft that rotates in an electric generator to produce electricity. The power in the wind is proportional to the area of the windmill being swept by the wind, the cube of the wind speed and the air density, which varies with altitude.

Mathematically,

$$P = \frac{1}{2} \times \rho \times A \times V^3$$

where  $\rho$  is the air density in kilograms per cubic meter ( $\text{kg/m}^3$ )  
 $A$  is the swept rotor area in square meters ( $\text{m}^2$ )  
 $V$  is the wind speed in meters per second ( $\text{m/s}$ )

The kinetic energy in the wind depends on the density of the air, i.e., its mass per unit of volume. Heavier the air, the more energy is received by the turbine. The rotor area determines how much energy a wind turbine is able to harvest from the wind. With doubling of rotor diameter, energy increases by four times. Power in the wind is proportional to the

cubic wind speed. This is because the kinetic energy of an air mass is proportional to  $V^2$  and the amount of air mass moving past a given point is proportional to wind velocity,  $V$ . Hence, identifying a site for a windmill with relatively high mean wind speed is worthwhile.

Although the above equation derives the power in the wind, the actual power that can be extracted from the wind is significantly lower than this figure and it depends upon several factors like the type of machine and rotor used the blade design, friction losses, and the other losses. The real amount of power that can be extracted from the wind has its physical limits. The physical limit of the maximum power that can be extracted by any windmill is 59.3%, defined as Betz limit. The realistic figure varies in the range from 30% to 45%. Therefore, the power available from the machine is given by:

$$P_a = \frac{1}{2} \times C_p \times \rho \times A \times V^3$$

where  $C_p$  is the coefficient of performance of the wind machine

### 3.4 ► SOURCES OF ENERGY

The sources of energy can be classified as renewable and non-renewable. A renewable form of energy can be regenerated and source of energy is infinite, for example, solar energy, wind energy, tidal energy, geothermal energy are the renewable type of energy. In contrast to renewable energy, non-renewable energy cannot be regenerated and its source is limited for example coal, petroleum, fossil fuels, nuclear power, etc. are non-renewable form of energy.

#### 3.4.1 Renewable Energy

Renewable energy comes from the sources that can theoretically be renewed as quickly as they are consumed. If used at a sustainable rate, these sources will be available for consumption for thousands of years or longer. Unfortunately, some potentially renewable energy sources, such as biomass and geothermal, are being depleted in some areas because the usage rate exceeds the renewal rate.

**Solar Energy:** Solar energy is the ultimate energy source of energy available on the earth. Though only a small fraction of the solar energy reaches the earth's surface that is sufficient to meet the world's energy requirements. The process of directly converting solar energy to heat or electricity is considered a renewable energy source. Solar energy has been used to heat homes and water, and modern technology such as photovoltaic cells has provided a way to produce electricity from sunlight.

**There are Two Basic Forms of Radiant Solar Energy Use:** passive and active. Passive solar energy systems are static and do not require the input of energy in the form of moving parts or pumping fluids to utilize the sun's energy. Buildings can be designed to capture and collect

the sun's energy directly. A southern exposure greenhouse with glass windows and a concrete floor is an example of a passive solar heating system.

Active solar energy systems require the input of some energy to drive mechanical devices such as solar panel, which collect the energy and pump fluids used to store and distribute the energy. Solar panels are generally mounted on a south or west-facing roof. A solar panel usually consists of a glass-faced, sealed, insulated box with a black matte interior finish. Inside are coils full of a heat collecting medium such as water. The sun heats the water in the coils, which is pumped to the coils in a heat transfer tank containing water. The water in the tank is heated and then either stored or pumped through the building to heat rooms or supply hot water to taps in the building.

**Photovoltaic Cells:** A group of cells are linked together to provide the required flow of current. The electricity can be used directly or stored in storage batteries. Because photovoltaic cells have no moving parts, they are clean, quiet, and durable. The recent development of inexpensive semiconductor materials has helped greatly to lower the cost to the point where solar electric panels can compete cost wise with traditionally produced electricity.

**Hydroelectric Energy:** Hydroelectric power is generated by converting the kinetic and/or pressure energy of water into shaft power (mechanical work) producing electricity with the help of a generator. Hydroelectric power is generated with the help of dams across the rivers. A dam built across river creates a reservoir. The head of the water behind the dam is greater than that below the dam, representing stored potential energy. When water flows down through the penstock of the dam, the potential energy is converted into electricity driving the turbines coupled to a generator.

**Wind Power:** Wind is the result of the sun's uneven heating of the atmosphere. Warm air expands and rises, and cool air contracts and sinks. This movement of the air is called wind. The wind has been used as an energy source for a long time. It has been used to pump water, to power ships and to mill grains. Areas with constant and strong winds can be used by wind turbines to generate electricity. The major drawbacks of wind-powered generators are—they require lots of open lands and a fairly constant wind supply. Windmills are also noisy, and some people consider them aesthetically unappealing and label them as visual pollution.

**Biomass Energy:** Biomass energy is the oldest source of energy used by human beings. It is the organic matter that composes the tissues of plants and animals. It can be burned for heating and cooking, and even generating electricity. The most common source of biomass energy is from the burning of wood, but energy can also be generated by burning animal manure, herbaceous plant material, peat, or converted biomass such as charcoal. Biomass can also be converted into a liquid biofuel such as ethanol or methanol. Biomass is a potentially renewable energy source. Unfortunately, trees that are cut for firewood are frequently not replanted. The use of biomass as a fuel source has serious environmental effects. When harvested trees are not replanted, soil erosion can occur. The loss of

trees results in increased amounts of carbon dioxide in the atmosphere and contributes to global warming.

**Geothermal Energy:** Geothermal energy uses heat from the earth's internal geological processes in order to produce electricity or provide heating. One source of geothermal energy is steam. Groundwater percolates down through cracks in the subsurface rocks until it reaches rocks heated by underlying magma, and the heat converts the water to steam. Sometimes this steam makes its way back to the surface in the form of a geyser or hot spring. Wells can be dug to tap the steam reservoir and bring it to the surface to drive generating turbines, and produce electricity. Hot water can be circulated to heat buildings. Regions near tectonic plate boundaries have the best potential for geothermal activity.

### 3.4.2 Non-renewable Energy

Over 85% of the energy used in the world is from non-renewable sources. Most of the developed nations are dependent on non-renewable energy sources such as fossil fuels (coal and oil) and nuclear power. These sources are called non-renewable because they cannot be renewed or regenerated quickly enough to keep pace with their use.

**Coal:** Coal is the most abundant fossil fuel in the world with an estimated reserve of one trillion metric tons. Coal is formed slowly over millions of years from the buried remains of ancient swamp plants. During the formation of coal, the carbonaceous matter was first compressed into a spongy material called 'peat', which is about 90% water. As the peat became more deeply buried, the increased pressure and temperature turned it into coal. Different types of coal resulted from differences in the pressure and temperature that prevailed during formation. The softest coal (about 50% carbon), which also has the lowest energy output, is called lignite. Lignite has the highest water content (about 50%) and relatively low amounts of smog-causing sulfur. With increasing temperature and pressure, lignite is transformed into bituminous coal (about 85% carbon and 3% water). Anthracite (almost 100% carbon) is the hardest coal and also produces the greatest energy when burned.

**Oil:** Crude oil or liquid petroleum is a fossil fuel that is refined into many different energy products (e.g., gasoline, diesel fuel, jet fuel, and heating oil). Oil forms underground in rock such as shale, which is rich in organic materials. After the oil forms, it migrates upward into porous reservoir rock such as sandstone or limestone, where it can become trapped by an overlying impermeable cap rock. Wells are drilled into these oil reservoirs to remove the gas and oil. Over 70% of oil fields are found near tectonic plate boundaries because the conditions there are conducive to oil formation. Despite its limited supply, oil is a relatively inexpensive fuel source. It is a preferred fuel source over coal. An equivalent amount of oil produces more kilowatts of energy than coal. It also burns cleaner, producing about 50% less sulfur dioxide. Oil, however, does cause environmental problems. The burning of oil releases atmospheric pollutants such as sulfur dioxide, nitrogen oxide, carbon dioxide, and

carbon monoxide. These gases are smog precursors that pollute the air and greenhouse gases that contribute to global warming. Another environmental issue associated with the use of oil is the impact of oil drilling. Substantial oil reserves lie under the ocean. Oil spill accidents involving drilling platforms kill marine organisms and birds. Some reserves such as those in northern Alaska occur in wilderness areas. The building of roads, structures, and pipelines to support oil recovery operations can severely impact the wildlife in those natural areas.

**Natural Gas:** Natural gas production is often a by-product of oil recovery, as the two commonly share underground reservoirs. Natural gas is a mixture of gases, the most common being methane ( $\text{CH}_4$ ). It also contains some ethane ( $\text{C}_2\text{H}_6$ ), propane ( $\text{C}_3\text{H}_8$ ), and butane ( $\text{C}_4\text{H}_{10}$ ). Natural gas is usually not contaminated with sulfur and is, therefore, the cleanest burning fossil fuel. After recovery, propane and butane are removed from the natural gas and made into liquefied petroleum gas (LPG). LPG is shipped in special pressurized tanks as a fuel source for areas not directly served by natural gas pipelines (e.g., rural communities). The remaining natural gas is further refined to remove impurities and water vapor and then transported in pressurized pipelines. Natural gas is highly flammable and is odorless. The characteristic smell associated with natural gas is actually that of minute quantities of a smelly sulfur compound, which is added during refining to warn consumers of gas leaks. The use of natural gas is growing rapidly. Besides being a clean burning fuel source, natural gas is easy, and inexpensive to transport once pipelines are in place. In developed countries, natural gas is used primarily for heating, cooking, and powering vehicles. It is also used in a process for making ammonia fertilizer.

**Nuclear Power:** In most electric power plants, water is heated and converted into steam, which drives a turbine generator to produce electricity. Fossil-fueled power plants produce heat by burning coal, oil, or natural gas. In a nuclear power plant, the fission of uranium atoms in the reactor provides the heat to produce steam for generating electricity. Several commercial reactor designs are currently used. The most widely used design consists of a heavy steel pressure vessel surrounding a reactor core. The reactor core contains the uranium fuel, which is formed into cylindrical ceramic pellets and sealed in long metal tubes called fuel rods. Thousands of fuel rods form the reactor core. Heat is produced in a nuclear reactor when neutrons strike uranium atoms, causing them to split in a continuous chain reaction. Control rods, which are made of a material such as boron that absorbs neutrons, are placed among the fuel assemblies. When the neutron-absorbing control rods are pulled out of the core, more neutrons become available for fission and the chain reaction speeds up, producing more heat. When they are inserted into the core, fewer neutrons are available for fission, and the chain reaction slows or stops, reducing the heat generated. Heat is removed from the reactor core area by water flowing through it in a closed pressurized loop. The heat is transferred to a second water loop through a heat exchanger. The water also serves to slow down or 'moderate' the neutrons, which are necessary for sustaining the fission reactions. The second loop is kept at a lower pressure, allowing the water to boil and create steam,

which is used to power the turbine generator and produce electricity. Nuclear fission does not produce atmospheric pollution or greenhouse gases and its proponents expected that nuclear energy would be cheaper and last longer than fossil fuels. Unfortunately, because of construction cost overruns, poor management, and numerous regulations, nuclear power ended up being much more expensive than predicted. The nuclear accidents at Three Mile Island in Pennsylvania and the Chernobyl Nuclear Plant in the Ukraine, recently in 2011 nuclear radiation in Japan due to earthquake and tsunami raised concerns about the safety of nuclear power. Furthermore, the problem of safely disposing of spent nuclear fuel remains unresolved. The United States has not built a new nuclear facility in over 20 years, but with continued energy crises across the country that situation may change.

## RECAP ZONE .....



### Points to Remember

- The convertibility of energy into work depends on its availability.
- Thermodynamics is a branch of science and engineering that deals with the interaction of energy mainly in the forms of heat and work.
- Thermodynamics is concerned with the thermal behavior of a matter and its interaction with other physical and chemical behavior of the matter.
- The **prime mover** is a primary source of power. All the machinery that provides power for performing various kinds of mechanical work is prime movers.
- It is a group of machines that transform various forms of energy such as thermal, electrical, or pressure into mechanical form.
- Engines, turbines, pumps, actuators, etc. are the examples of prime movers.
- **Power plant engineering** is a branch of engineering which deals with the conversion of various forms of energy into electrical energy.
- Thermal power plants may be coal based or gas based.
- In coal based power plant, coal is used as burning fuel and the heat energy is transferred to water to convert it into superheated steam.
- In gas based power plant or gas power plant, air is compressed to high pressure and heat energy is added to compressed air using combustion chamber by direct burning of fuel in compressed air or indirect heat transfer to compressed air.
- The high-pressure and high-temperature air is expanded in the gas turbine, which is coupled to a generator which generates electricity due to shaft rotation.
- The principle of electricity generation in the case of **hydroelectric power plant** is same as in thermal power plant only difference is that the shaft power to the turbine is provided by pressure and kinetic energy of water in place of steam in thermal power.
- In a **nuclear power plant**, the nuclear energy released from radioactive materials due to fission reaction is utilized to heat the water and convert it into superheated steam.
- ${}_{92}\text{U}^{235}$ ,  ${}_{94}\text{Pu}^{239}$ ,  ${}_{92}\text{U}^{233}$  are nuclear fuel used in a nuclear reactor to release the heat energy.
- In Uranium ore,  ${}_{92}\text{U}^{235}$  is available only up to 0.7% remaining is  ${}_{92}\text{U}^{238}$ .

- The moderator is a material which is used to reduce the kinetic energy of fast neutron (1MeV or 13200 km/sec to 0.25eV or 2200 m/sec) within a fraction of second to maintain the fission chain reaction.
- $H_2$ ,  $D_2$ ,  $N_2$ , C, Heavy water, Be, are some important moderators.
- The function of the control rod is to start the nuclear chain reaction when the reactor is started from cold, to maintain the chain reaction at steady state condition, and to shut down the reactor automatically under an emergency condition.
- The common materials used for control rods are cadmium, boron or hafnium.
- The **nuclear reactors** can be classified on the basis of neutron energy, fuel used, moderator used, and coolant used.
- On the basis of neutron energy, we can classify the nuclear reactor as Fast reactor and thermal reactor;
- On the basis of fuel used, we can classify them as a natural fuel reactor and enriched uranium reactor;
- On the basis of moderator, we can classify them as a water moderated, heavy water moderated, graphite moderated, and Beryllium moderated;
- On the basis of coolant, we can classify them as water cooled reactor, gas cooled reactor.
- The sources of energy can be classified as renewable and non-renewable. A renewable form of energy can be regenerated and source of energy is infinite, for example, solar energy, wind energy, tidal energy, and geothermal energy are a renewable form of energy.
- In contrast to renewable energy, non-renewable energy cannot be regenerated and its source is limited for example coal, petroleum, fossil fuels, nuclear power, etc. are nonrenewable form of energy.

## REVIEW ZONE .....



### Multiple-choice Questions

1. The radiation in the sunlight that gives us feeling of hotness is:
  - (a) Visible radiation
  - (b) Infra-red
  - (c) Red
  - (d) Ultra-violet
2. Which of the following is not a source of bio-mass:
  - (a) Gobar gas
  - (b) Coal
  - (c) Wood
  - (d) Nuclear energy
3. Which of the following is not derived from the sun:
  - (a) Biomass
  - (b) Fossil fuels
  - (c) Nuclear energy
  - (d) Geothermal energy
4. The substance producing a lot of heat on burning is called as:
  - (a) Oxidizing agent
  - (b) Biogas
  - (c) Biomass
  - (d) Fuel
5. The fuel formed under the earth's surface by the decomposition of organic matter is called:
  - (a) Organic fuel
  - (b) Bio gas
  - (c) Fossil fuel
  - (d) Underground fuel
6. The main constituent of LPG is:
  - (a) Methane
  - (b) Butane
  - (c) Hydrogen
  - (d) Propane
7. The main constituent of CNG is:
  - (a) Methane
  - (b) Butane
  - (c) Hydrogen
  - (d) Propane
8. Which of the following is not a renewable source of energy?
  - (a) The sun
  - (b) Natural gas
  - (c) Wind
  - (d) Ocean tidal energy
9. Which of the following is not a combustible gas?
  - (a) Oxygen
  - (b) Hydrogen
  - (c) Butane
  - (d) Methane
10. A solar cell converts:
  - (a) Heat energy into electrical energy
  - (b) Solar energy into electrical energy
  - (c) Heat energy into light energy
  - (d) Solar energy into light energy

11. The scientist who first carried out critical nuclear fission reaction is:  
 (a) Otto Hahn (b) Enrico Fermi  
 (c) Hans Bethe (d) Einstein
12. The sources of energy of the sun is:  
 (a) Nuclear fission (b) Chemical reaction  
 (c) Nuclear fusion (d) Photoelectric effect
13. The fuel used in the nuclear reactor is:  
 (a) Cadmium  
 (b) Radium  
 (c) Uranium  
 (d) Thorium
14. In a hydroelectric power plant, which of the following is used to produce shaft power?  
 (a) The pressure and kinetic energy of stored water  
 (b) Heat energy of water  
 (c) Heat energy of flue gas  
 (d) Nuclear energy
15. In a Thermal power plant, which of the following is used to produce shaft power?  
 (a) The pressure and kinetic energy of stored water  
 (b) Heat energy of water  
 (c) Heat energy of flue gas  
 (d) Nuclear energy
16. In a Gas power plant, which of the following is used to produce shaft power?  
 (a) The pressure and kinetic energy of stored water  
 (b) Heat energy of water  
 (c) Heat energy of flue gas  
 (d) Nuclear energy

## Answers

- |         |         |         |         |         |         |
|---------|---------|---------|---------|---------|---------|
| 1. (b)  | 2. (d)  | 3. (c)  | 4. (d)  | 5. (c)  | 6. (b)  |
| 7. (a)  | 8. (b)  | 9. (a)  | 10. (b) | 11. (b) | 12. (c) |
| 13. (c) | 14. (a) | 15. (b) | 16. (c) |         |         |

## Theory Questions

- What is prime movers? Discuss its importance in energy conversion.
- Explain the concept of energy and transformation of one form to another.
- What is a prime mover? Give some examples of reciprocating and rotating prime movers.
- Explain the principle of working of thermal power plant.
- Explain the principle of working of a gas power plant.
- Explain the principle of working of the hydroelectric power plant.
- Explain the principle of working of nuclear power plant.
- Explain the terms used in nuclear power plant such as fuels, fissile materials, moderators, control rods, working fluids, shield, etc.
- Explain the basis for classification of nuclear reactors.
- Differentiate pressurized water reactor and boiling water reactor.
- What do you mean by renewable and non-renewable sources of energy?
- Write short notes on solar energy, wind power energy, biomass, and geothermal energy.
- Write short notes on the application of coal, oil, natural gas, and nuclear energy.
- \*14. Explain briefly the principle of conversion of solar energy directly on to electrical energy in a solar cell.
- \*15. What is meant by renewable and non-renewable energy sources? Give suitable examples of each.
- \*16. What is the origin of biomass energy? What are the main advantages and disadvantages of it?

\* indicates that similar questions have appeared in various university examinations.



- \*17. What are the most favorable sites for installing wind turbines?
- \*18. Draw the layout of a simple thermal power plant and explain the function of its various parts.
- \*19. What are the advantages and disadvantages of nuclear power plant?
- \*20. Discuss the merits and demerits of renewable and non-renewable sources of energy with suitable examples.
- \*21. What are the methods of harnessing solar energy? Explain the principle of wind-mill.
- \*22. Describe with a neat sketch the construction and working of a nuclear power plant. Describe the working principle of the high head hydel power station.
- \*23. What are the salient features of conventional energy sources?
- \*24. Explain the working of a solar flat collector.
- \*25. Describe with neat sketch the working principle of the high-head hydel power plant: (a) What are its advantages over other power plants? (b) Explain the use of cooling tower in thermal power plant.
- \*26. What are the various forms of energy? List the non-conventional sources of energy.
- \*27. Write a short note on solar energy?
- \*28. Discuss the hydraulic turbines and gas turbines?
- \*29. Discuss the function of condensers.
- \*30. Write a short note on wind energy and its conversion.

# Properties of Steam and Steam Generators

## Learning Objectives

*By the end of this chapter, the student will be able:*

- To describe the thermodynamic properties of steam
- To differentiate the different types of boilers
- To describe the function of mountings and accessories in a boiler
- To measure the performance of boilers

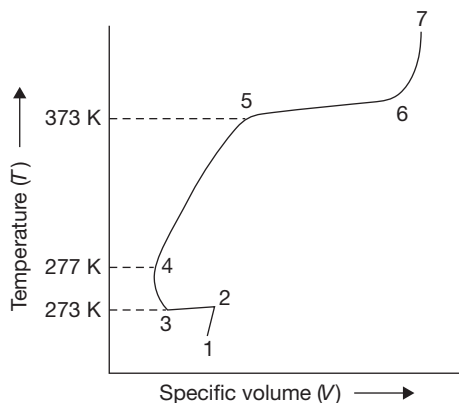
### 4.1 ► INTRODUCTION

Steam is a gaseous form of water, which has a large number of industrial applications. Steam is widely used for power generation purpose. Also, it has applications in chemical, leather, and other industries. Most of the nuclear and thermal power plants use steam to run the turbines and finally to generate electrical power. Therefore, all the engineers require basic idea about steam properties, the steam generation process, and apparatus for steam generation.

### 4.2 ► FORMATION OF STEAM AT CONSTANT PRESSURE

Steam is the gaseous form of water and ice. When heat applied to the ice at  $0^{\circ}\text{C}$  is equal to the latent heat of fusion plus sensible heat from  $0^{\circ}\text{C}$  to  $100^{\circ}\text{C}$  plus latent heat of vaporization, ice is transformed into steam. Three variables are very important that are pressure, temperature, and volume. At constant pressure variation in temperature and volume can be explained by Figure 4.1.

Suppose unit mass of ice below freezing point is kept in a cylinder and a constant pressure is applied by a piston with a constant load. Now the heat is applied. From point 1 and 2 ice gets warm up and temperature increases with volume. The temperature at point 2 is 273 K.

**FIGURE 4.1**

T-V Diagram for Various Phases of Water

From point 2 to 3, the temperature remains constant due to the heat added is absorbed in phase transition as latent heat of fusion ( $h_{fg}$ ). At point 3 ice transforms completely into the water. On further heating from point 3 to 4, volume decreases up to 4°C (277 K), since water has a high density at 4°C. This is sensible heating. From point 4 to 5, temperature and volume, both increase on sensible heating. Again from point 5 to 6, the temperature remains constant, but the volume increases due to phase transition from water to vapor. Heat absorbed in this phase is latent heat of vaporization. At point 6, water transforms completely into vapor. Beyond point 6, the vapor is superheated and temperature rises continuously. This temperature rise is known as the degree of superheat. If several graphs are plotted between temperature and volume at different pressures, we get a curve which is shown in Figure 4.2.

At a pressure of 0.006112 bar, the melting point and boiling point become equal and change of phase ice-water-vapor is shown by a single straight line ABC as shown in Figure 4.2, is known as a triple point line. At this line, all the three phases are in equilibrium ( $P_{\text{triple}} = 0.006112$  bar,  $T_{\text{triple}} = 273.16^\circ\text{C}$ ). At a very high pressure, latent heat of vaporization becomes zero, which is known as critical point ( $P_c = 221.2$  bar,  $T_c = 647.3^\circ\text{C}$ ,  $V_c = 0.00317$  m<sup>3</sup>/kg).

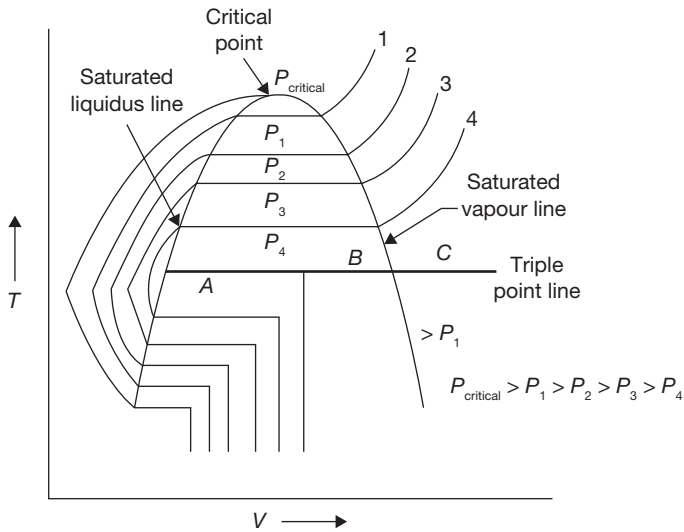
Similarly, P-V diagram, T-S diagram, h-S diagram, P-S diagram are shown in Figure 4.3:

### Enthalpy Change in Generation of Steam from 0°C

At 0°C

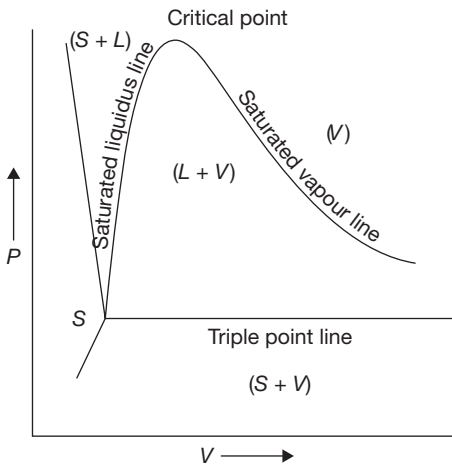
$$h_0 = u_0 + PV_0; \text{ at } 0^\circ\text{C}, u_0 = 0$$

$$\therefore h_0 = PV_0; \quad \text{where } V_0 \text{ is specific volume at } 0^\circ\text{C}.$$



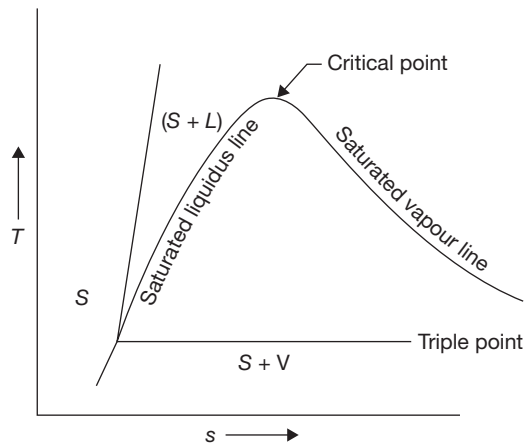
**FIGURE 4.2**

T-V Diagram at Different Pressures



**FIGURE 4.3 (a)**

P-V Diagram



**FIGURE 4.3 (b)**

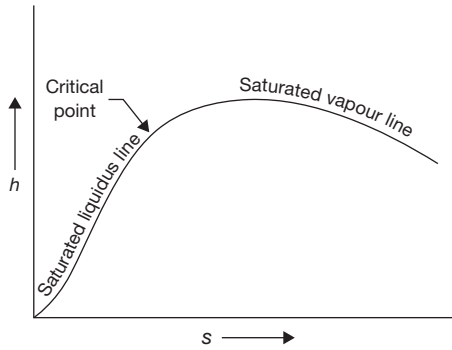
T-S Diagram

**0°C to Saturation Temperature**

$$h_f = u_f + PV_f \text{ where } V_f \text{ is specific volume at saturation temperature.}$$

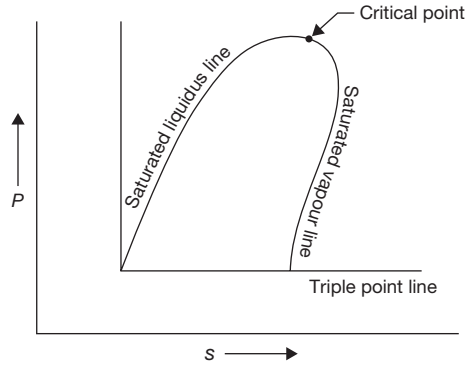
$$h_0 = PV_0$$

$$\therefore h_f - h_0 = h = u_f + P(V_f - V_0)$$



**FIGURE 4.3 (c)**

h-S Diagram



**FIGURE 4.3 (d)**

P-S Diagram

*For Complete Transformation of Steam*

$$h_{fg} = h_g - h_f = (u_g - u_f) + P (V_g - V_f) \text{ kJ/kg}$$

*Wet Steam*

Wet steam contains partly water as suspended in it and partly steam.

*Dryness Fraction*

Dryness fraction is defined as the mass of dry steam per kg of wet steam. It is represented by  $x$ .

$$x = \frac{m_g}{m_g + m_f}$$

*Enthalpy*

$$h = xh_g + (1 - x) h_f = h_f + xh_{fg}$$

*Specific Volume*

$$V = xV_g + (1 - x) V_f = V_f + xV_{fg}$$

*Internal Energy*

$$u_f = h_f - P_f V_f$$

$$u_g = h_g - P_g V_g$$

*Entropy of Water*

$$\Delta S = S_2 - S_1 = \int_{T_1}^{T_2} \frac{C_p dT}{T} = C_p \log_e \frac{T_2}{T_1}; \quad \text{at constant pressure}$$

### Entropy of Steam

$$S = S_f + S_{fg} = C_p \log_e \frac{T_S}{T_0} + \frac{h_{fg}}{T_S} \text{ for dry saturated steam at constant pressure } (x = 1)$$

$$S = S_f + xS_{fg} = C_p \log_e \frac{T_S}{T_0} + \frac{xh_{fg}}{T_S} \text{ for wet steam at constant pressure}$$

$$S = S_f + xS_{fg} + S_g = C_{pw} \log_e \frac{T_S}{T_0} + \frac{xh_{fg}}{T_S} + C_p \log_e \frac{T_{Sup}}{T_S} \text{ for superheated steam at constant pressure}$$

where  $C_{pw} \approx 1$ , specific heat of water.

Since the value of  $C_p$  varies, the values of entropy from these equations are not accurate and this can be taken from the steam table.

### EXAMPLE 4.1

- Find the temperature, enthalpy, entropy, internal energy, the specific volume of 1 kg of dry saturated steam at 10 bar.
- What are the changes in these properties from saturated liquid to dry saturated vapor at the same pressure?

### SOLUTION

- From the steam table, properties of dry saturated steam at 10 bar or 1 MPa are given below:

Temperature,  $t = 179.91^\circ\text{C}$

$$V_f = 1.127 \text{ cm}^3/\text{g} = 0.00127 \text{ m}^3/\text{kg}$$

$$h_f = 762 \text{ kJ/kg}$$

$$h_g = 2,778.1 \text{ kJ/kg}$$

$$S_f = 2.1387 \text{ kJ/kg K}$$

$$S_g = 6.5865 \text{ kJ/kg K}$$

$$u_g = 2,583.66 \text{ kJ/kg}$$

- Change in temperature = 0

$$\begin{aligned} \text{Change in enthalpy, } h_{fg} &= h_g - h_f = 2,778.1 \text{ kJ/kg} - 762 \text{ kJ/kg} \\ &= 2,016.1 \text{ kJ/kg} \end{aligned}$$

$$\text{Change in entropy, } S_{fg} = S_g - S_f = 4.4478 \text{ kJ/kg K}$$

$$\begin{aligned} \text{Change in volume} &= V_g - V_f = 0.19444 \text{ m}^3/\text{kg} - 0.00127 \text{ m}^3/\text{kg} \\ &= 0.19317 \text{ m}^3/\text{kg} \end{aligned}$$

Change in internal energy,  $u_{fg} = u_g - u_f$

$$\begin{aligned} u_f &= h_f - P_f V_f = 762 \text{ kJ/kg} - 10 \times 10^2 \text{ kPa} \times 0.00127 \text{ m}^3/\text{kg} \\ &= 760.73 \text{ kJ/kg} \end{aligned}$$

$$\begin{aligned} u_g - u_f &= 2,583.66 \text{ kJ/kg} - 760.73 \text{ kJ/kg} \\ &= 1,822.93 \text{ kJ/kg} \end{aligned}$$

**EXAMPLE 4.2**

A  $2 \text{ m}^3$  drum is to be completely filled with any saturated steam at 10 bar. First, the drum is evacuated, then the necessary amount of water is filled and evaporated by heating.

- What mass of water is required and what will be the temperature of the vapor?
- If the drum finally contains a two-phase system with a dryness fraction of 90%. What will be the required mass?

**SOLUTION**

From Steam Table:

Saturation temperature at 10 bar =  $179.91^\circ\text{C}$

Volume,  $V_g = 0.19444 \text{ m}^3/\text{kg}$ ,  $V_f = 0.001127 \text{ m}^3/\text{kg}$

$$(a) \text{ Mass of water required} = \text{Volume of drum} / \text{Specific Volume of vapor} \\ = 2 / 0.19444 = \mathbf{10.285 \text{ kg}}$$

$$(b) \text{ Volume at 10 bar, } V = V_f + x \cdot V_{fg} = 0.001127 \text{ m}^3/\text{kg} + 0.9 \\ (0.19444 \text{ m}^3/\text{kg} - 0.001127 \text{ m}^3/\text{kg}) \\ = 0.17510 \text{ m}^3/\text{kg}$$

$$\text{Mass of water required} = 2 \text{ m}^3 / 0.1751087 \text{ m}^3/\text{kg} = \mathbf{11.421 \text{ kg}}$$

**EXAMPLE 4.3**

A container of Volume  $0.05 \text{ m}^3$  contains a mixture of saturated water and saturated steam at temperature  $300^\circ\text{C}$ . The mass of water is 10 kg. Find the pressure, mass, specific volume, enthalpy, entropy and internal energy.

**SOLUTION**

From temperature based saturated steam table:

At  $300^\circ\text{C}$ ,  $P_{\text{sat}} = 8.581 \text{ bar}$ ,  $V_f = 1.404 \times 10^{-3} \text{ m}^3$ ,  $V_g = 0.02167 \text{ m}^3 / \text{kg}$ .

$h_f = 1344 \text{ kJ} / \text{kg}$ ,  $h_{fg} = 1404.9 \text{ kJ} / \text{kg}$ ,  $h_g = 2749 \text{ kJ} / \text{kg}$

$S_f = 3.2534 \text{ kJ} / \text{kgK}$ ,  $S_g = 5.7045 \text{ kJ} / \text{kgK}$

$$\text{Volume of water} = 10 \text{ kg} \times V_f = 10 \text{ kg} \times 0.001404 \text{ m}^3/\text{kg} = 0.01404 \text{ m}^3$$

$$\begin{aligned} \text{Volume of steam} &= \text{volume of container} - \text{volume of water} = 0.05 \text{ m}^3 - 0.01404 \text{ m}^3 \\ &= 0.03596 \text{ m}^3. \end{aligned}$$

$$\begin{aligned} \text{Mass of steam} &= \text{Volume of steam} / \text{Specific volume of steam} = 0.03596 \text{ m}^3 / 0.02167 \text{ m}^3/\text{kg} \\ &= \mathbf{1.659 \text{ kg}}. \end{aligned}$$

$$\text{Total mass of mixture} = \text{mass of water} + \text{mass of steam} = 10 \text{ kg} + 1.659 \text{ kg} = \mathbf{11.659 \text{ kg}}.$$

$$\begin{aligned} \text{Quality of steam, } X &= \text{mass of steam} / (\text{mass of water} + \text{mass of steam}) = 1.659 \text{ kg} / 11.659 \text{ kg} \\ &= \mathbf{0.1422} \end{aligned}$$

$$\begin{aligned} V &= V_f + xV_{fg} = 0.001404 \text{ m}^3 / \text{kg} + 0.1422(0.02167 \text{ m}^3 / \text{kg} - 0.001404 \text{ m}^3 / \text{kg}) \\ &= \mathbf{4.287 \times 10^{-3} \text{ m}^3 / \text{kg}}. \end{aligned}$$

$$h = h_f + xh_{fg} = 1344 \text{ kJ} / \text{kg} + 0.1422(1404.9 \text{ kJ} / \text{kg}) = \mathbf{1543.774 \text{ kJ} / \text{kg}}.$$

$$\begin{aligned} S &= S_f + xS_{fg} = 3.2534 \text{ kJ} / \text{kgK} + 0.1422(5.7045 \text{ kJ} / \text{kgK} - 3.2534 \text{ kJ} / \text{kgK}) \\ &= \mathbf{3.6019 \text{ kJ} / \text{kgK}} \end{aligned}$$

$$\begin{aligned} u &= h - PV = 1543.778 \text{ kJ} / \text{kg} - 8.581 \times 10^2 \text{ kPa} \times 4.287 \times 10^{-3} \text{ m}^3 \\ &= \mathbf{1540.09 \text{ kJ} / \text{kg}} \end{aligned}$$

#### EXAMPLE 4.4

Steam at 1 MPa, 300°C and flowing at the rate of 1 kg/s passes into a pipe carrying wet steam at 1 MPa and 0.8 dryness fraction. After adiabatic mixing, the flow rate becomes 2.5 kg/s as shown in Figure 4.4. Determine the condition of steam after mixing.

#### SOLUTION

$$m_2 = m_3 - m_1 = 2.5 \text{ kg/sec} - 1 \text{ kg/sec} = 1.5 \text{ kg/sec}.$$

From steady flow energy equation

$$m_1 h_1 + m_2 h_2 = m_3 h_3 \quad (4.1)$$

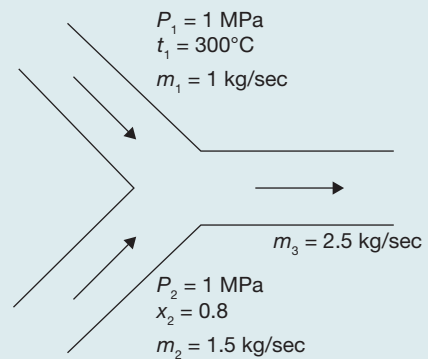
$$\text{At } 1 \text{ MPa, } 300^\circ \text{C, } h_1 = h_g = 3051.2 \text{ kJ/kg}$$

$$h_f = 762 \text{ kJ/kg; } h_{fg} = 2015.3 \text{ kJ/kg}$$

$$h_2 = h_f + xh_{fg} = 762 \text{ kJ/kg}$$

$$+ 0.8 \times 2015.3 \text{ kJ/kg}$$

$$= 2374.24 \text{ kJ/kg}.$$



**FIGURE 4.4**

Mixing of Two Streams of Steam



Putting the values of  $h_1$  and  $h_2$  in Equation 4.1

$$1\text{ kg} \times 3051.2\text{ kJ/kg} + 1.5\text{ kg} \times 2374.24\text{ kJ/kg} = 2.5\text{ kg} \times h_3$$

$$h_3 = 2645.024\text{ kJ/kg}$$

Now enthalpy at 1 MPa saturated steam =  $2774.1\text{ kJ/kg} = h_g$

$$h_g > h_3$$

Hence, steam is wet steam

$$2645.024\text{ kJ/kg} = h_3 = h_f + xh_{fg} = 762\text{ kJ/kg} + x \times 2015.3\text{ kJ/kg}$$

or,  $x = 0.9343$

Saturation temperature at 1 MPa =  $179.91^\circ\text{C}$

### EXAMPLE 4.5

At 1.2 MPa,  $250^\circ\text{C}$  steam enters into a turbine and expands to  $30^\circ\text{C}$ . Determine the work output of turbine for 10 kg/s flow rate steam.

### SOLUTION

$h$ - $s$  diagram for steam expansion is shown in Figure 4.5.

From steam table, at 1.2 MPa and  $250^\circ\text{C}$

$$h_1 = 2935\text{ kJ/kg}, S_1 = 6.8294\text{ kJ/kgK}$$

Since expansion is adiabatic, entropy remains constant

$$S_1 = S_2 = 6.8294\text{ kJ/kgK}$$

From saturated steam table, at  $30^\circ\text{C}$

$$S_2 = S_f + xS_{fg} = 0.4369\text{ kJ/kgK} + x(8.4533\text{ kJ/kgK} - 0.4369\text{ kJ/kgK})$$

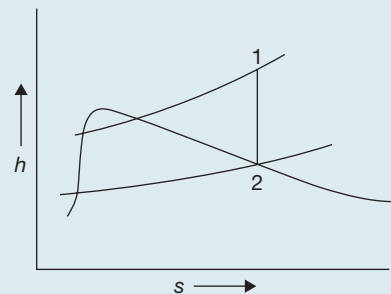
$$\text{As } S_1 = S_2, 6.8294\text{ kJ/kgK} = 0.4369\text{ kJ/kgK} + x(8.4533\text{ kJ/kgK} - 0.4369\text{ kJ/kgK})$$

$$x = 0.7974$$

$$h_2 = h_f + xh_{fg} = 125.79\text{ kJ/kg} + 0.7974 \times 2430.5\text{ kJ/kg} = 2063.9382\text{ kJ/kg}$$

$$\text{Work output} = h_1 - h_2 = 2935\text{ kJ/kg} - 2063.93\text{ kJ/kg} = 871.061\text{ kJ/kg}$$

$$\text{For 10 kg of steam} = 10\text{ kg} \times 871.061\text{ kJ/kg} = \mathbf{8710.61\text{ kJ}}$$



**FIGURE 4.5**

$h$ - $s$  Diagram

**EXAMPLE 4.6**

1.0 kg wet steam of quality 0.7 at 0.3 MPa pressure is heated at constant pressure till the temperature rises to 300°C. Calculate the amount of energy added as heat.

**SOLUTION**

$h$ - $s$  diagram for pressure rise of steam is shown in Figure 4.6

At point 1 in Figure 4.6

$$X = 0.7, P_1 = 0.3 \text{ MPa}$$

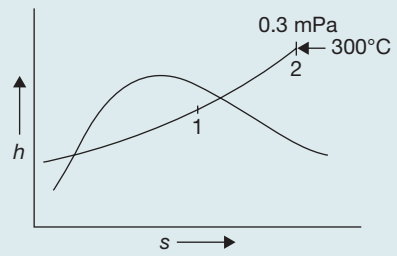
From Steam table

$$h_f = 561.47 \text{ kJ/kg}, \quad h_{fg} = 2163.8 \text{ kJ/kg}$$

$$h_1 = h_f + xh_{fg} = 561.47 \text{ kJ/kg} + 0.7 \times 2163.8 \text{ kJ/kg} = 2076.13 \text{ kJ/kg}$$

At 0.3 MPa and 300°C, from steam table;  $h_2 = 3069 \text{ kJ/kg}$

$$\text{Heat added} = h_2 - h_1 = 3069.3 \text{ kJ/kg} - 2076.13 \text{ kJ/kg} = \mathbf{993.17 \text{ kJ/kg}}$$


**FIGURE 4.6**

$h$ - $s$  Diagram

**EXAMPLE 4.7**

A boiler of volume  $10 \text{ m}^3$  contains wet steam of quality 0.8 at 0.5 MPa pressure. The inlet and outlet valves of the boiler are closed and the energy addition as heat is stopped. After some time, the pressure of the steam is found to be 0.2 MPa.

Determine:

- the mass of liquid, the mass of vapor in the boiler at the beginning,
- the mass of liquid and mass of vapor in the boiler at the end, and
- the energy lost as heat to the surroundings.

From steam table, at 0.5 MPa, saturation temperature,  $t_s = 151.86^\circ\text{C}$

$$V_f = 1.093 \times 10^{-3} \text{ m}^3 / \text{kg} = 0.001093 \text{ m}^3 / \text{kg}$$

$$V_g = 0.379 \text{ m}^3 / \text{kg}, \quad h_f = 640.23 \text{ kJ/kg}, \quad h_{fg} = 2108.5 \text{ kJ/kg}$$

## SOLUTION

$$h_g = 2748.7 \text{ kJ/kg}$$

Initial internal energy per kg is given by

$$u_1 = (h_1 + x_1 h_{fg}) - x_1 P_1 V_{g1}$$

Volume of the boiler is given by  $V_1 = m \{x_1 V_{g1} + (1 - x_1) V_{f1}\}$ , where  $m$  is mass of steam

$$10 \text{ m}^3 = m \times (0.8 \times 0.3749 \text{ m}^3 + 0.2 \times 0.001093 \text{ m}^3)$$

or,  $m = 33.342 \text{ kg}$ .

(a) Thus, mass of steam =  $33.342 \text{ kg} \times 0.8 = \mathbf{26.6736 \text{ kg}}$

Mass of water =  $33.342 \text{ kg} \times 0.2 = \mathbf{6.668 \text{ kg}}$ .

Suppose quality of steam at final state is  $x_2$ ,  $m x_1 V_{g1} = m x_2 V_{g2}$

Since value of  $V_f$  is negligible in the equation  $x_1 V_{g1} + (1 - x_1) V_{f1} = x_2 V_{g2} + (1 - x_2) V_{f2}$

From steam table, at  $0.2 \text{ MPa}$ ,

$$V_{g2} = 0.8857 \text{ m}^3 / \text{kg}, \quad V_{f2} = 0.001061 \text{ m}^3 / \text{kg}$$

$$h_{f2} = 504.70 \text{ kJ/kg}, \quad h_{fg2} = 2201.9 \text{ kJ/kg}$$

$$h_{g2} = 2706.7 \text{ kJ/kg}$$

$$x_2 = \frac{0.8 \times 0.3749 \text{ m}^3 / \text{kg}}{0.8857 \text{ m}^3 / \text{kg}} = 0.3386$$

(b) Mass of steam =  $x_2 (m_w + m_g) = x_2 m = 0.3386 \times 33.342 \text{ kg} = \mathbf{11.28 \text{ kg}}$

Mass of water =  $33.342 \text{ kg} - 11.28 \text{ kg} = \mathbf{22.062 \text{ kg}}$

(c) Final internal energy/kg at  $0.2 \text{ bar}$  is given by

$$\begin{aligned} u_2 &= (h_{f2} + x_2 h_{fg2}) - x_2 P_2 V_{g2} = (504.7 \text{ kJ/kg} + 0.3386 \times 2201.9 \text{ kJ/kg}) \\ &\quad - 0.3386 \times 0.2 \times 10^3 \text{ kPa} \times 0.8857 \text{ m}^3 \\ &= 1190.28 \text{ kJ/kg} \end{aligned}$$

Heat rejected = Change in internal energy during constant volume process

$$m(u_1 - u_2) = 33.342 \text{ kg}(2177.07 \text{ kJ/kg} - 1190.28 \text{ kJ/kg}) = \mathbf{32901.552 \text{ kJ}}$$

## EXAMPLE 4.8

A pressure cooker contains  $1 \text{ kg}$  of saturated steam at  $6 \text{ bar}$ . Find the quantity of heat which must be rejected to reduce the quality of steam to  $0.8$ . Determine the pressure and temperature of steam at the new state.

## SOLUTION

From steam table, at 6 bar,  $t_{sat} = 158.85^\circ\text{C}$

$$V_{f1} = 0.00101\text{m}^3 / \text{kg}, \quad V_{g1} = 0.3157\text{m}^3 / \text{kg}$$

$$h_{f1} = 670.56\text{kJ} / \text{kg}, \quad h_{fg1} = 2086.3\text{kJ} / \text{kg}$$

$$h_{g1} = 2756.8\text{kJ} / \text{kg}$$

Volume of pressure cooker =  $1\text{kg} \times V_{g1} = 1\text{kg} \times 0.3157\text{m}^3 / \text{kg} = 0.3157\text{m}^3$

Volume remains constant, hence,  $V_1 = V_2 = 0.3157\text{m}^3$

Initial internal energy of steam per kg =  $h_{g1} - P_1V_{g1}$

$$u_1 = 2756.8\text{kJ} / \text{kg} - 6 \times 10^2\text{kPa} \times 0.3157\text{m}^3 = 2567.38\text{kJ} / \text{kg}$$

Now suppose quality of the steam at the end is  $x$

$$x = 0.8(\text{given})$$

$$V_1 = V_2 = 0.3157\text{m}^3 = \{(1-x) \times V_{f2} + x \times V_{g2}\} \times 1\text{kg} = V_{g2} \times x$$

or,

$$V_{g2} = \frac{0.3157\text{m}^3}{0.8} = 0.3946\text{m}^3$$

Pressure corresponding to  $0.3946\text{m}^3/\text{kg} = \mathbf{0.44\text{ MPa}}$  (using linear interpolation in steam table value)

$$t_s = \mathbf{146^\circ\text{C}}, \quad h_f = 619\text{kJ} / \text{kg}, \quad h_{fg} = 2123\text{kJ} / \text{kg}, \quad h_g = 2742\text{kJ} / \text{kg}$$

$$V_g = 0.3946\text{m}^3 / \text{kg}, \quad V_f = 0.00108\text{m}^3 / \text{kg}$$

$$\begin{aligned} u_2 &= h_2 - x_2 P_2 V_{g2} = (619\text{kJ} / \text{kg} + 0.8 \times 2123\text{kJ} / \text{kg}) - 0.8 \times 0.44 \times 10^3\text{kPa} \times 0.3946\text{m}^3 \\ &= 2178.448\text{kJ} / \text{kg} \end{aligned}$$

$$\text{Total heat transfer} = 2178.448\text{kJ} - 2567.38\text{kJ} = \mathbf{-1911\text{kJ}}$$

## EXAMPLE 4.9

A sample steam has  $5^\circ\text{C}$  as the degree of superheat. Before and after throttling, its pressures are 40 bar and 1 bar, respectively. Calculate the dryness fraction.

**SOLUTION**

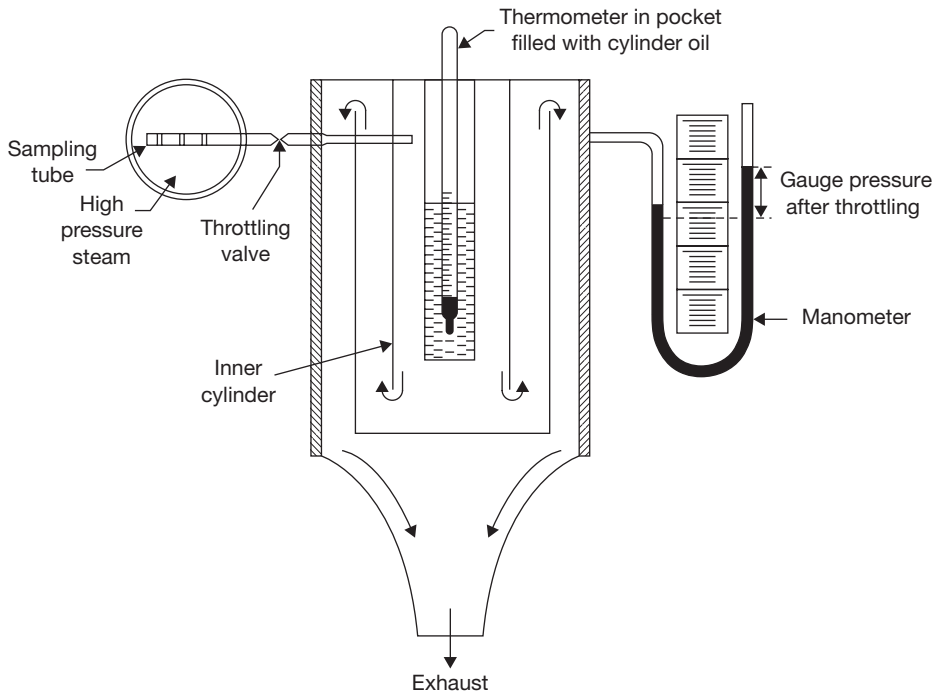
$$\begin{aligned}
 h_{f1} + x_1 h_{fg} &= h_{g2} + C_p (t_{\text{sup}} - t_{s2}) \\
 x_1 &= \frac{h_{g2} + C_p (t_{\text{sup}} - t_{s2}) - h_{f1}}{h_{fg}}; \text{ where } C_p = 0.48 \\
 &= \frac{2675.7 \text{ kJ/kg} + 0.48 \text{ kJ/kgK} \times 5 \text{ K} - 1086 \text{ kJ/kg}}{1710 \text{ kJ/kg}} = 0.93
 \end{aligned}$$

**4.3 ► THROTTLING CALORIMETER**

Throttling calorimeter is a device used in the determination of the dryness fraction of steam. There is a sampling tube, which is placed in the steam main pipe. It consists of a hole facing upstream to get sample steam. The steam passes through the throttle valve and then flows into the inner cylinder. The main condition is that after throttling steam should be superheated. Normally, the degree of superheat should be 5°C. The pressure after throttling should be a few mm of  $H_g$  above atmospheric pressure as recorded by a manometer. The saturation temperature corresponding to this pressure can be found. If the temperature recorded by the thermometer is more than saturation temperature, it is confirmed that steam is superheated after throttling. Steam flows from the top of the inner cylinder to the annular space between inner and outer cylinders. The calorimeter is insulated from the surroundings. Before taking a temperature reading, the flow of the steam should be in the steady state and all parts to be heated to keep temperature remains constant. The constructional details of calorimeter are shown in Figure 4.7.

- Let
- $P_1$  = Initial pressure of steam
  - $P_2$  = Final pressure = Atmospheric pressure + manometer reading
  - $h_{f1}$  = Enthalpy of water at pressure,  $P_1$
  - $h_{fg1}$  = Enthalpy of vaporization at pressure,  $P_1$
  - $C_{pg}$  = Specific heat of superheated steam
  - $t_{s2}$  = Saturation temperature at final pressure,  $P_2$
  - $t_{\text{sup}}$  = Temperature recorded by thermometer
  - $x_1$  = Dryness fraction of steam before throttling

During throttling, enthalpy remains constant, i.e., enthalpy before throttling = enthalpy after throttling.


**FIGURE 4.7**

Throttling Calorimeter

Therefore,  $h_{f1} + x_1 h_{fg} = h_{g2} + C_p (t_{\text{sup}} - t_{s2})$

or, 
$$x_1 = \frac{h_{g2} + C_p (t_{\text{sup}} - t_{s2}) - h_{f1}}{h_{fg}}; \text{ where } C_p = 0.48$$

Limitation of the process is that the steam should be superheated after throttling.

### EXAMPLE 4.10

A throttling calorimeter is used to measure the dryness fraction of the steam in steam main which has steam flowing at 10 bar. The steam after passing through the calorimeter is at 1 bar pressure and 120°C. Calculate the dryness fraction of the steam in the steam main. Take  $c_{ps} = 2.1 \text{ kJ/kgK}$ .

### SOLUTION

From steam table:

At pressure,  $P_1 = 10 \text{ bar}$ ,  $h_{f1} = 762.81 \text{ kJ/kg}$ ,  $h_{fg1} = 2015.3 \text{ kJ/kg}$ .

After throttling, at pressure,  $P_2 = 1$  bar,  $t_s = 99.63^\circ\text{C}$ ,  $h_{g2} = 2675.5$  kJ/kg. Enthalpy remains constant during throttling process, Therefore,  $h_1 = h_2$

$$h_{f1} + x.h_{fg1} = h_{g2} + c_{ps}(t_{\text{sup}2} - t_{s2})$$

$$762.81 \text{ kJ/kg} + x \times 2015.3 \text{ kJ/kg} = 2675.5 \text{ kJ/kg} + 2.1 \text{ kJ/kgK}(120^\circ\text{C} - 99.63^\circ\text{C})$$

$$X = 0.97$$

#### 4.4 ► SEPARATING AND THROTTLING CALORIMETER

A pure separating calorimeter suffers from a disadvantage that the steam passing out after water separation may not be completely dry, or it may have higher dryness fraction. Only in throttling calorimeter, a high dryness fraction (93%) can be found. Thus a combined separating and throttling calorimeter may be used to measure the dryness fraction of steam. The sample steam is first passed through separating calorimeter, where most of the moisture is separated and measured and then the dryer steam is passed into the throttling calorimeter. A schematic diagram of separating and throttling calorimeter is shown in Figure 4.8.

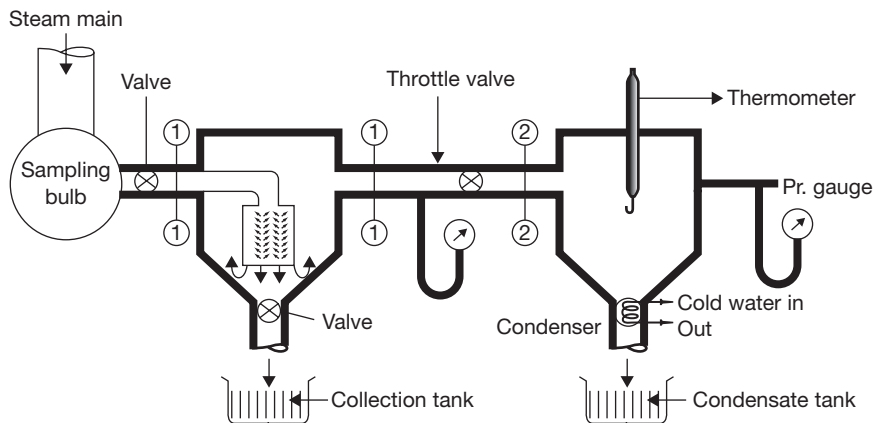
Let  $M$  = mass of steam passing through throttling calorimeter.

$x_2$  = the dryness fraction entering into the throttling calorimeter that is determined by throttling calorimeter.

$m$  = mass of water separated out in separating calorimeter.

$x$  = dryness fraction of steam entering the separating calorimeter.

$$\text{Thus, } x = \frac{M}{M+m} x_2 \quad \text{or,} \quad x = x_1 \times x_2; \quad \text{where } x_1 = \frac{M}{M+m}.$$



**FIGURE 4.8**

Separating and Throttling Calorimeter

**EXAMPLE 4.11**

Following data was obtained on combined separating and throttling calorimeter:

Pressure of steam sample = 20 bar, pressure steam at exit = 1 bar, temperature of steam at the exit = 160°C, discharge from separating calorimeter = 1 kg/min., discharge from throttling calorimeter = 15 kg/min. Determine the dryness fraction of the sample steam.

**SOLUTION**

Pressure of sample steam,  $P_1 = P_2 = 20$  bar, pressure at the exit,  $P_3 = 1$  bar, temperature of steam at the exit,  $t_{\text{sup}3} = 180^\circ\text{C}$ , discharge from separating calorimeter,  $m = 1$  kg/min., discharge of dry steam from throttling calorimeter,  $M = 15$  kg/min.

At  $P_1 = P_2 = 20$  bar,  $h_{f2} = 908.79$  kJ/kg,  $h_{fg2} = 1890.7$  kJ/kg.

At  $P_3 = 1$  bar and 160°C,  $h_3 = h_{g3} = 2796.2$  kJ/kg

$$h_{f2} + x_2 h_{fg2} = h_{g3}$$

$$\text{or, } 908.79 \text{ kJ/kg} + x_2 \cdot 1890.7 \text{ kJ/kg} = 2796.2 \text{ kJ/kg}$$

$$x = 0.998 \times x_1 = (M \times 0.998) / (M + m)$$

$$= (15 \text{ kg} / \text{kg} \times 0.998) / (15 \text{ kg} + 1 \text{ kg}) = \mathbf{0.935}$$

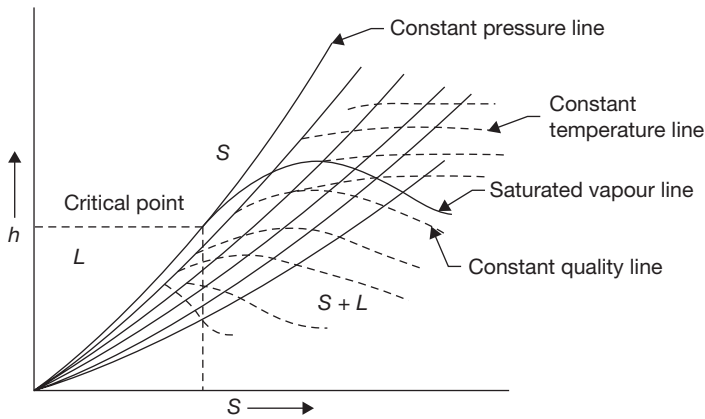
**4.5 ► STEAM TABLE**

The properties of steam are pressure, temperature, volume, enthalpy, entropy, internal energy. These values are determined experimentally and tabulated as a steam table. Separate steam tables for saturated and superheated are used. If the temperature of the steam is more than the saturation temperature, it is known as superheated steam and the temperature difference of saturated steam and superheated steam is known as the degree of superheat. The steam tables for saturated and superheated steam are included in Appendix I of this book.

**4.6 ► MOLLIER DIAGRAM OR  $h$ - $S$  CHART**

Mollier diagram is a graph between enthalpy and entropy. Various properties of steam can be shown graphically on this diagram. Natures of various lines are shown in Figure 4.9. A complete Mollier diagram is shown in Appendix II at the end of this book.





**FIGURE 4.9**

Mollier Diagram

## 4.7 ► STEAM GENERATORS/BOILERS

The steam generator is a combination of apparatus, which is used in power generation and supply of steam in various plants. Its main purpose is to transfer the heat produced by fuel to water; water is converted into different types of steam as per requirements, such as wet steam, saturated steam, and superheated steam. A steam generator is also known as a boiler. It may be defined as “A combination of apparatus for producing, furnishing or recovering heat together with apparatus for transferring the heat so made available to water, which would be heated and vaporized to steam form” (ASME).

### 4.7.1 Classification of Boilers

There is a number of models of a boiler having different industrial applications. The boiler can be classified on the following basis:

- (i) Contents inside the tube
- (ii) Firing system
- (iii) Position of drum
- (iv) Pressure
- (v) Nature of water circulation

On the basis of contents of the tube, boilers can be classified as **Fire tube boilers** and **water tube boilers**. In fire tube boilers, flue gas passes through the tube and the heat of flue gas is absorbed by tube and transferred to water surrounding the tube, for example, Cochran boiler, Locomotive boiler, Lancashire boiler, and Cornish boiler. But, in water tube boilers,

water flows inside the tube and tube is kept in the path of flow of flue gas, for example, Babcock and Wilcox Boiler, Benson boiler, Loffler boiler, etc. Most of the high-pressure boilers are water tube boiler. In this boiler, tube absorbs the heat of flue gas flowing surrounding the tube and transferred to water passing through the tube. The difference between water tube and fire tube boilers are given in Table 4.1.

**Table 4.1: Differences between water tube boilers and fire tube boilers**

Water Tube Boilers	Fire Tube Boilers
1. Water flows inside the tube.	1. Flue gas flows inside the tube.
2. It is safer than fire tube boilers because a large part of the water of hottest part of the furnace is in small tubes which if rupture, only a comparatively small volume of water released into a flash of steam.	2. It is more dangerous compared to water tube boiler.
3. It is more efficient and economical.	3. It is less efficient and economical.
4. Pressure limit in water tube boilers is much higher than the fire tube boilers.	4. Pressure limit is very low. It is approx 16-20 bar.
5. Water tube boilers are most suitable for large size boiler.	5. Fire tube boilers are most suitable for small size boiler.
6. In this boiler, the steam production rate is very high.	6. The steam Production rate is low.
7. The water treatment plant is required due to the problem of scaling inside the tube.	7. There is no need of water treatment plant.

On the basis of firing system, boilers can be classified as **Internal Fired Boilers** and **External Fired Boilers**. In internal fired boiler, firing takes place inside the boiler drum, i.e., furnace is located inside the drum, for example, Cochran boiler, Locomotive boiler, Lancashire boiler, etc. whereas in external fired boiler, furnace is outside the boiler drum and water is circulated inside the tube passing through the furnace, for example, Babcock and Wilcox Boiler.

On the basis of the position of the drum, boilers can be classified as a **horizontal boiler**, **inclined boiler**, and **vertical boiler**. On the basis of pressure, the boiler can be classified as a low-pressure **boiler**, high-pressure **boiler**, and **super critical boiler**. Low-pressure boilers operate below 80 bar; high-pressure boilers operate above 80 bar; and supercritical boilers operate at 221 bar and above. On the basis of the nature of the circulation of water, boilers can be classified as **natural circulation boilers** and forced circulation boiler. In natural circulation boilers, water circulates automatically due to the pressure difference created by the temperature difference. But, in forced circulated boilers, pumps are used to circulate the water through the tubes.

### 4.7.2 Requirements of a Good Boiler

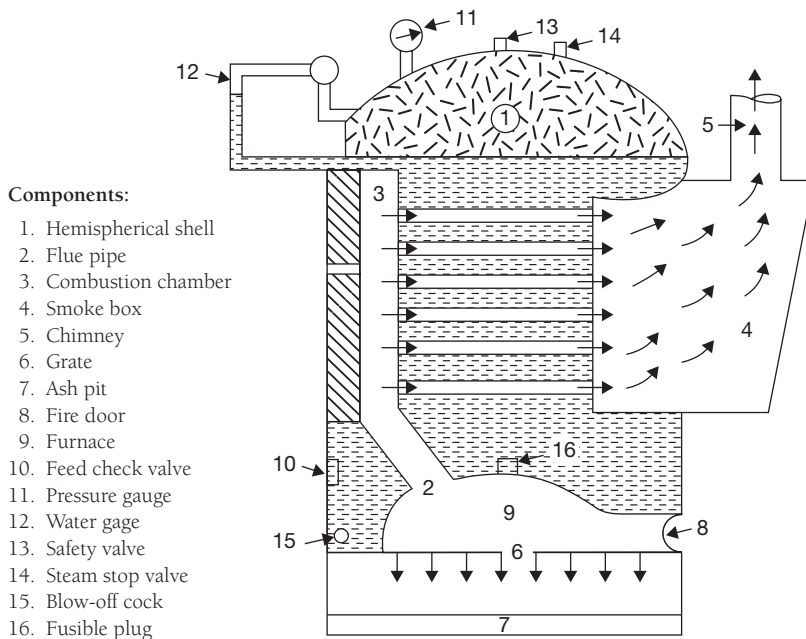
A good boiler should have the following properties:

1. Low cost of installation, operation, and maintenance
2. Easy maintenance

3. High efficiency
4. Safety
5. High transportability
6. High steam production rate
7. Good quality of steam
8. Quick steam generation capacity
9. Meeting fluctuating demand of steam, etc.

### 4.7.3 Cochran Boiler

It is fire tube, multitubular, internal fired and vertical boiler. Its maximum steam generation capacity is 3,500 kg/h. Its shell diameter and height are 2.75 meters and 5.8 meters, respectively. The fuel (coal) is fired on the grate in the furnace. The hot flue gas passes through the fire tube located in the water space and heat is transferred to the water. Water becomes hot in contact with the tube surface. Flue gas goes to the smoke box and finally in the atmosphere through the chimney. The circulation of water is natural; hot water rises up and cold water comes down as shown in Figure 4.10. The steam formed is collected at the upper space of the dome-shaped shell and supplied for use through a steam stop valve.



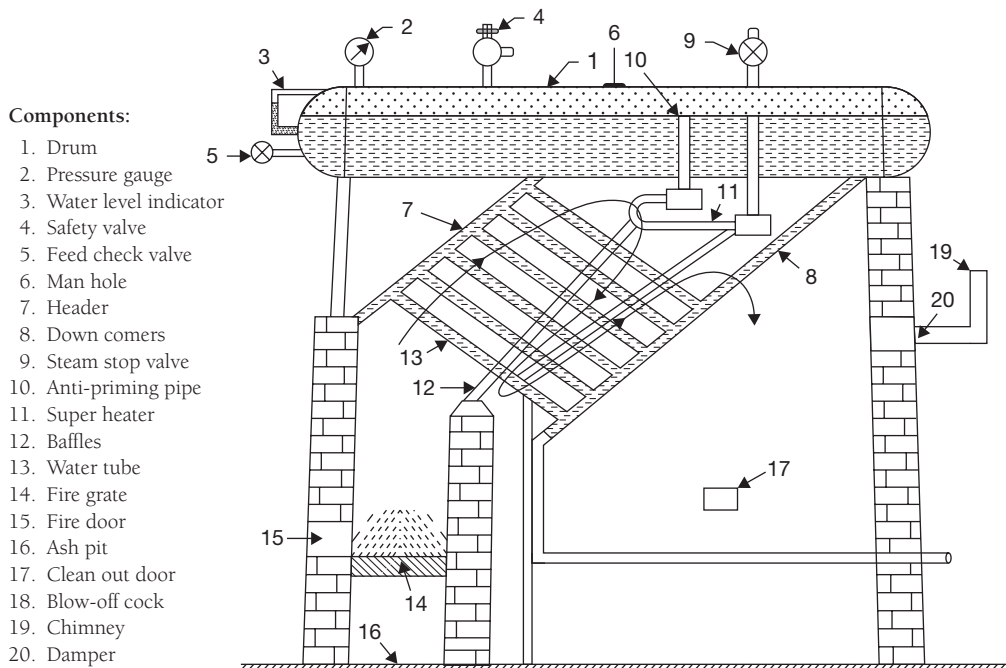
**FIGURE 4.10**

Cochran Boiler

The flames and hot gasses produced as a result of combustion of coal on the grate, rise in the dome-shaped combustion furnace. The unburnt fuel is reflected back to the grate and hot flue gas passes through the fire tubes and dissipates the heat to the water. Finally, the flue gas escapes into the atmosphere through smoke-box and chimney. Water circulation is natural circulation. Hot water rises up and cold water comes down continuously. Steam is collected in the upper space of the boiler.

#### 4.7.4 Babcock and Wilcox Boiler

Babcock and Wilcox boiler is a water tube, horizontal, multitubular, external fired boiler. It covers a wide range of pressures compared to fire tube boilers. It has a steam generating capacity of 20,000 to 40,000 kg/h. It operates at an average 20–22 bar, but it can be operated at the maximum 40–42 bar. Its tubes are inclined at  $5^\circ$  to  $15^\circ$  for natural circulation. The diameter and length of tubes are designed as per requirement of the pressure of steam. Baffles are arranged normally for two or three passes of combustion gas. All mounting and accessories are shown in Figure 4.11, which is explained later in this chapter. There is a natural circulation of water. Water circulates from drum to tube and tube to drum with the help of downtake and uptake headers. To get superheated steam, the steam collected in the



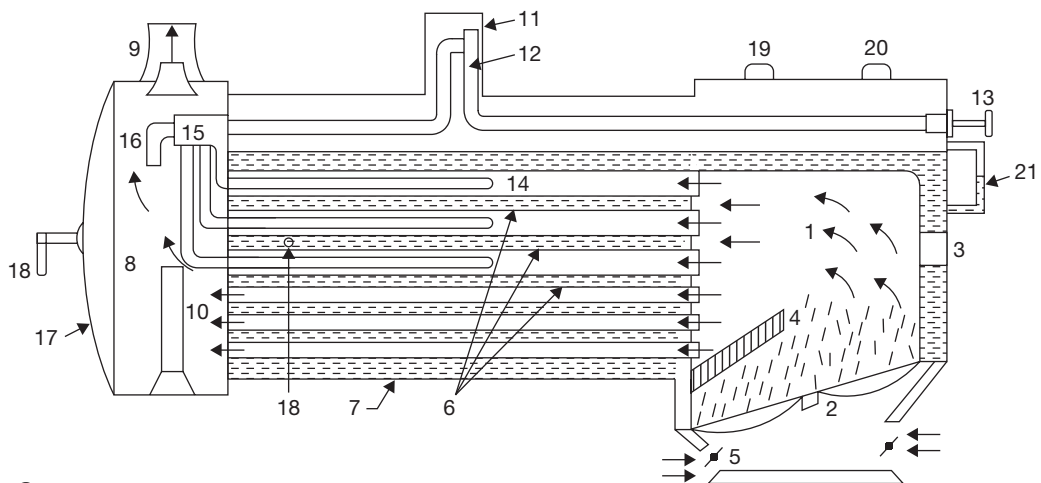
**FIGURE 4.11**

Babcock and Wilcox Boiler

upper space of the drum is recirculated through superheater. The hot flue gas as a result of combustion rises up and moves in the direction as directed by the baffles. The tubes get exposure of hot gas and transfer the heat to the water flowing inside the tubes. Hot water rises and reaches into the boiler drum and cold water comes down into the tubes. Water circulates due to natural circulation produced by temperature differences.

### 4.7.5 Locomotive Boiler

The locomotive boiler is a fire tube, horizontal, multitubular, natural circulation, movable, artificial draught, internal fired boiler. It meets the fluctuating demand of steam; its chimney height is very short. Artificial draught is created by supplying steam. It is generally used in a steam engine. The functions of all the mountings and accessories are discussed in the separate section of this chapter. The locomotive boiler is a movable boiler; therefore, its chimney is kept very small. A forced draught is created using the flow of steam. The flue gas passes through the tube as directed in Figure 4.12 and transfer the heat to the water through the tube walls.



#### Components:

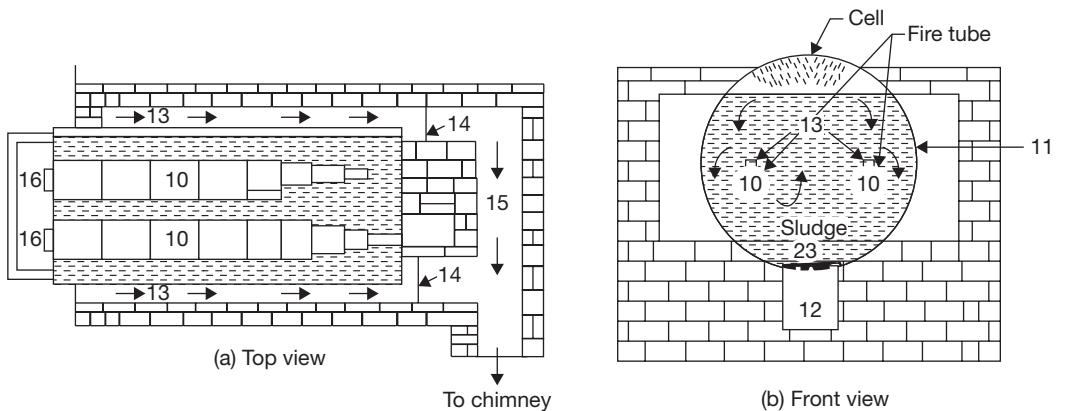
- |                     |                        |                         |                  |
|---------------------|------------------------|-------------------------|------------------|
| 1. Fire box         | 7. Barrel (shell)      | 13. Lever               | 19. Safety valve |
| 2. Grate            | 8. Smoke box           | 14. Super heater tubes  | 20. Whistle      |
| 3. Fire hole        | 9. Chimney             | 15. Super heater header | 21. Water gauge  |
| 4. Fire bridge arch | 10. Exhaust steam pipe | 16. Outlet pipe         |                  |
| 5. Ash pit          | 11. Steam dome         | 17. Smoke box door      |                  |
| 6. Fire tubes       | 12. Regulator          | 18. Feed check valve    |                  |

**FIGURE 4.12**

Locomotive Boiler

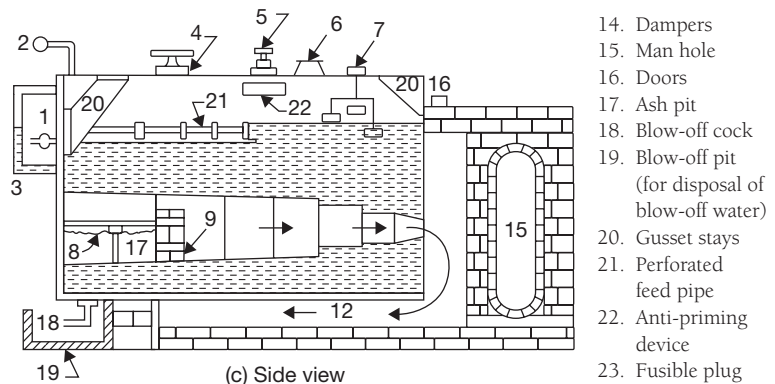
### 4.7.6 Lancashire Boiler

A Lancashire boiler is horizontal, fire tube, internal fired, natural circulation type boiler. There are two fire tubes. The fuel is burnt on the grate and the hot flue gas is produced. The flue gas moves along the furnace tubes and is deflected up by Fire Bridge. As soon as the flue gas reaches the back of main flue gas tubes, it deflects downwards and travels through the bottom flue gas tube as shown by arrows in Figure 4.13. The bottom flue is just below the water shell and heats the lower portion of the shell. After traveling from back to front, the flue gas bifurcates into separate paths in the side flues as shown by arrows in sectional side view. Now, it travels from front to back inside and heats the side of the water shell. These two streams of flue gas meet again in the main flue passing; through the damper, they are discharged to the atmosphere through the chimney.



#### Components:

1. Feed check valve
2. Pressure gauge
3. Water level Indicator
4. Dead weight safety valve
5. Steam stop valve
6. Man hole
7. High steam low water safety valve
8. Fire grate
9. Fire bridge
10. Flue tubes
11. Boiler shell
12. Bottom flue
13. Side flue



14. Dampers
15. Man hole
16. Doors
17. Ash pit
18. Blow-off cock
19. Blow-off pit (for disposal of blow-off water)
20. Gusset stays
21. Perforated feed pipe
22. Anti-priming device
23. Fusible plug

**FIGURE 4.13**

Lancashire Boiler

### 4.7.7 Cornish Boiler

Cornish boiler is similar to Lancashire boiler, but the number of tube is only one. Also, the dimension of the drum is smaller than that of Lancashire boiler. Rests are similar construction and operation.

## 4.8 ► BOILER MOUNTINGS

Boiler mountings are the components of boilers, which are mounted on the body of the boiler for safety and controlling the steam generation processes. There are following components which are used as mountings in boiler operation:

1. Safety valve, 2. Water level indicator, 3. Pressure gauge, 4. Fusible Plug, 5. Steam stop valve, 6. Feed check valve, 7. Blow-off cock, 8. Man and Mudhole.

### 4.8.1 Safety Valves

The safety valve is used to release the excess pressure inside the boiler drum. When the pressure inside the drum exceeds the working pressure, safety valves blow-off the steam into the atmosphere. Generally, four types of safety valves are used in boilers: (i) Dead weight safety valve, (ii) Spring loaded safety valve, (iii) Lever safety valve, and (iv) High steam low water safety valve.

#### *Dead Weight Safety Valve*

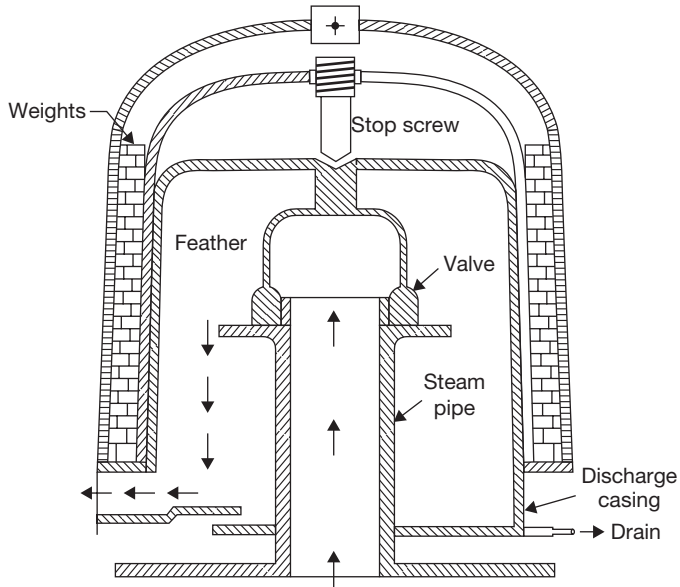
Steam pressure acting in an upward direction is counterbalanced by the dead weight of safety valve acting in the downward direction. When the steam pressure exceeds the dead weight of safety valve, valve rises from its valve seat and steam escapes into the atmosphere. The construction of dead weight safety valve is shown in Figure 4.14. There is a vertical steam pipe having a valve seat at its mouth. A valve is fitted in the valve seat. Above the valve, a dead weight is applied. When the steam pressure becomes higher than the dead weight, valve rises from the valve seat and steam at high pressure is released into the atmosphere. Again, when the steam pressure becomes normal, i.e., less than dead weight, the valve returns to the valve seat.

#### *Spring Loaded Safety Valve*

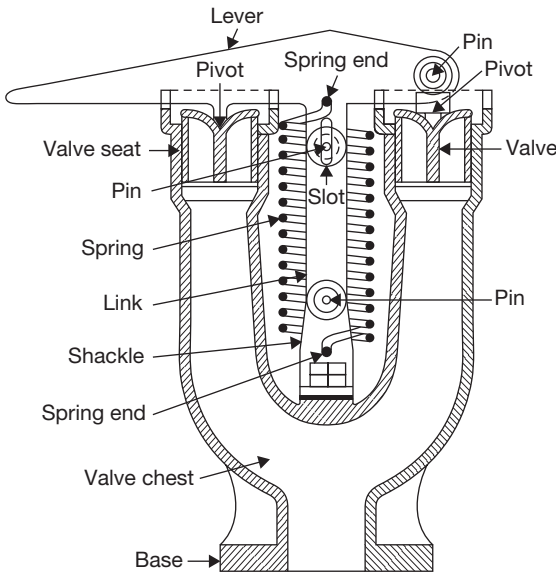
This type of safety valve is spring loaded. Spring force works against the steam pressure, when the steam pressure becomes high, valve lifted off the valve seat and steam is escaped out. A lever is attached to one end of spring as shown in Figure 4.15. When steam pressure comes down valve returns to valve seat due to the force of spring.

#### *Lever Safety Valve*

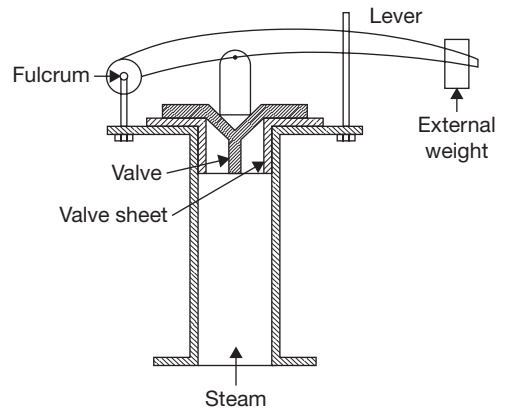
The lever safety valve works on the principle of the second system of the lever as shown in Figure 4.16. In this valve, there is a lever which can rotate about a fulcrum, but its movement



**FIGURE 4.14**  
Dead Weight Safety Valve



**FIGURE 4.15**  
Spring Loaded Safety Valve



**FIGURE 4.16**  
Lever Safety Valve



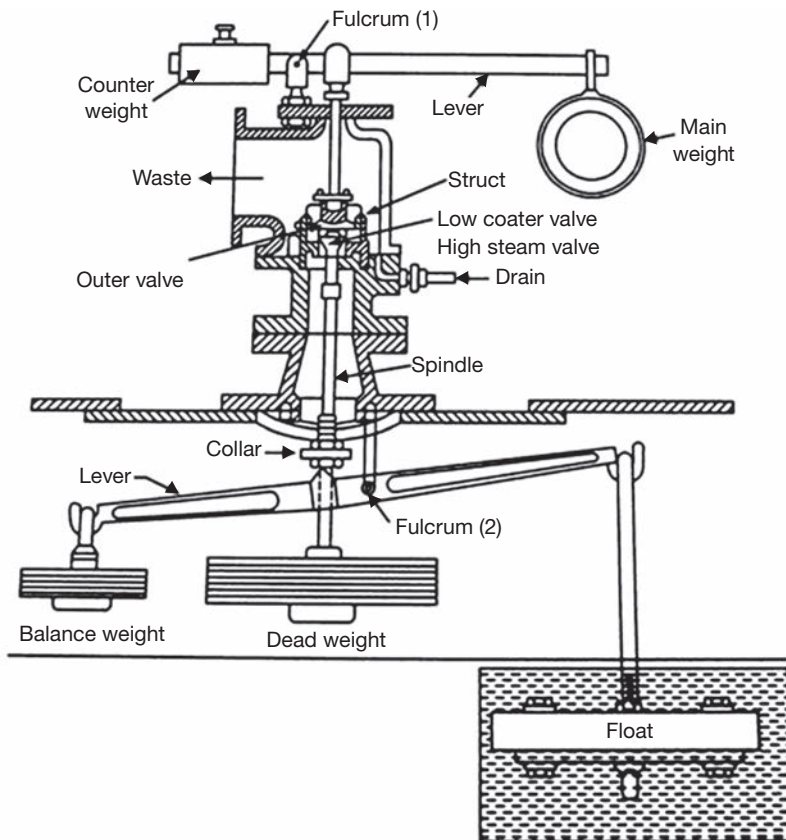
is limited by a guide. When the moment about fulcrum due to steam pressure exceeds the moment about fulcrum due to the weight applied on the lever valve is lifted off the seat and steam is escaped out. Again, the valve returns to its seat when the pressure becomes normal.

### 4.8.2 High Steam Low Water Safety Valve

There are following functions of high steam and low water safety valve:

- (i) To blow out steam if steam pressure becomes higher than the working pressure.
- (ii) To blow out steam when the water level in the boiler comes down.

The constructional details of the high-pressure low water safety valve are shown in Figure 4.17. The arrangement of the outer valve is similar to that of the lever loaded valve. The balance or counterweight can be fixed at any position along the arm with a set screw.



**FIGURE 4.17**

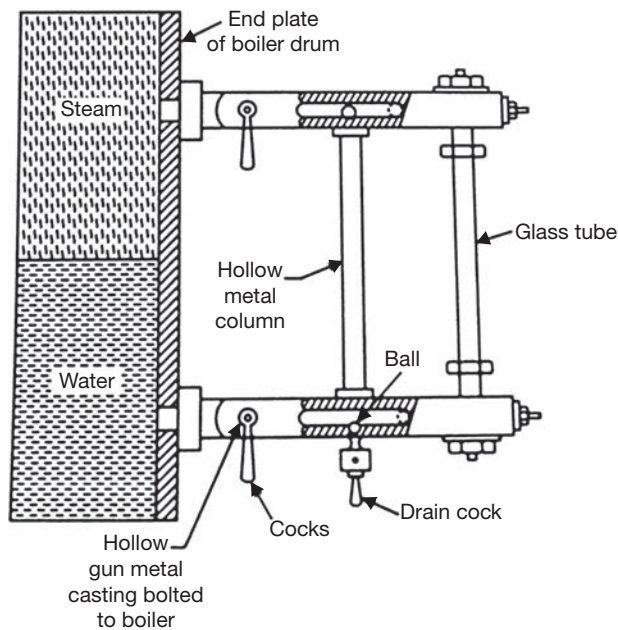
High Steam Low Water Safety Valve

The arrangement of inner valve and dead weight acts as a dead weight safety valve. But, the load on the outer valve is both due to dead weight and strut thrust. If the steam pressure exceeds the limit, valve lifts and steam escapes to waste.

The second lever is attached to a float at one end and a balance weight at the other end. When the float is submerged in water, the lever is balanced about the fulcrum. As soon as the float is uncovered, it gets unbalanced and tilts the lever towards the right. Due to tilting, it pushes the collar of the spindle in an upward direction and raising the valve from its seat. Thus, steam starts escaping through the waste pipe. A drain pipe is provided to drain out the condensed steam.

### 4.8.3 Water Level Indicator

The function of the water level indicator is to show the water level inside the boiler drum. Total two water level indicators are provided on the boiler drum. The constructional details are shown in Figure 4.18. One end of the glass tubes is connected to steam space and the other end to the water space through a hollow pipe of Gunmetal bolted to the boiler. In case, tube breaks, two balls are provided that move to the dotted positions due to the rush of water in the passage. The steam will also rush from the upward hollow column and will push the balls in dotted positions.



**FIGURE 4.18**

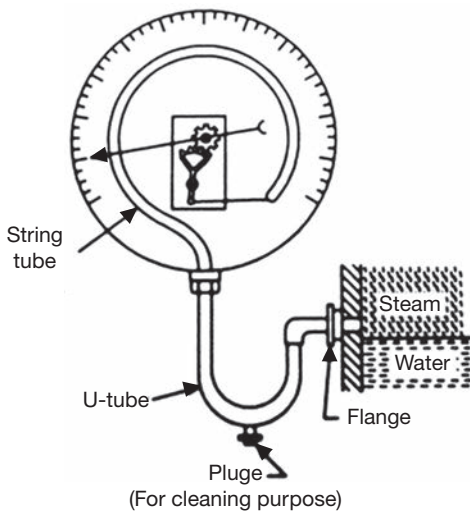
Water Level Indicator

### 4.8.4 Pressure Gauge

Pressure Gauge is used to measure the pressure inside the boiler drum. The constructional details are shown in Figure 4.19. There is a tube spring, one end of which is connected to the steam space and the other end is closed and connected to a link. The link is connected to toothed quadrant meshed with the pinion. At the center of the pinion, a pointer is fixed which can rotate with pinion. The quadrant rotates about the pivot and magnifies the reading. Due to steam pressure, spring tube tends to become straight and moves the pinion, which rotates the quadrant and pinion. The deflection in the pointer is shown on graduation on the disc, which shows the pressure of steam in the drum.

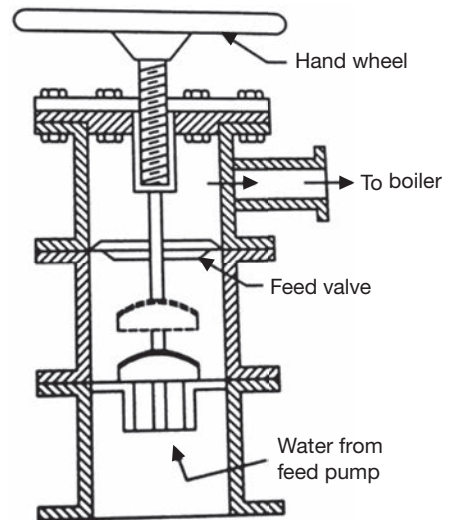
### 4.8.5 Feed Check Valve

The function of feed check valve is to allow the flow of water under pressure from the feed pump to the boiler and to prevent the back flow of water in case of failure of the feed pump. The constructional details are shown in Figure 4.20. The valve rises under pressure and water is allowed to flow inside the drum. The pressure of feed pump is more than that of steam inside the drum which allows the flow of water into the drum, but when supply is stopped, the valve returns to its seat due to steam pressure and prevents backflow of water. This is a one-way valve.



**FIGURE 4.19**

Pressure Gauge

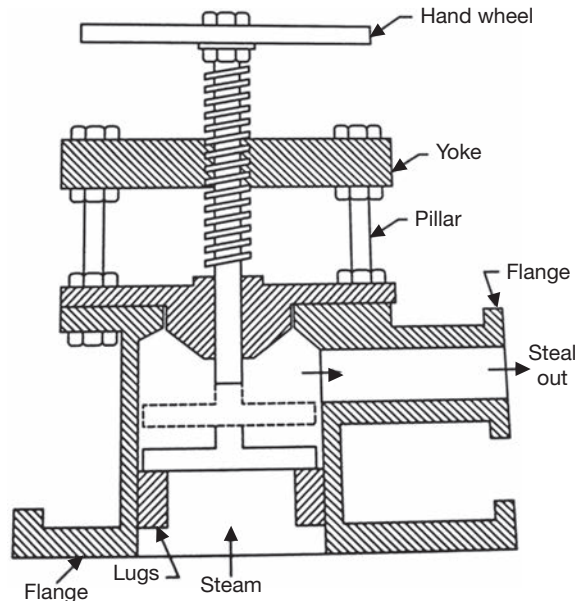


**FIGURE 4.20**

Feed Check Valve

### 4.8.6 Steam Stop Valve

The function of steam stop valve is to stop or allow the flow of steam from the boiler to steam pipe or from the steam pipe to supply. The opening of the valve is controlled by a hand wheel. The constructional details of steam stop valve are very simple which is shown in Figure 4.21.

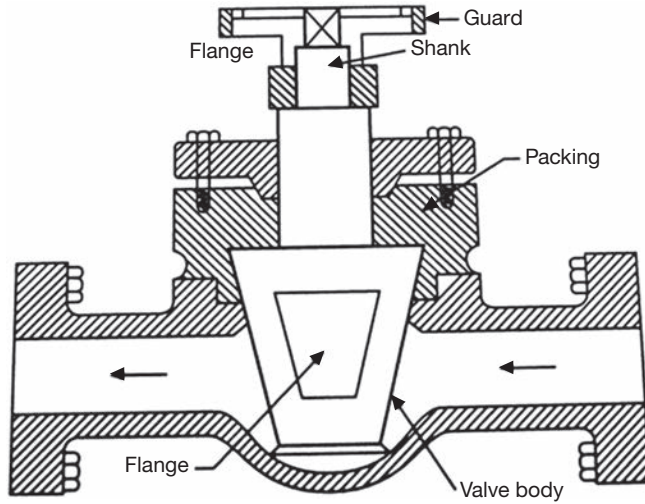


**FIGURE 4.21**

Steam Stop Valve

### 4.8.7 Blow-off Cock

The function of the blow-off cock is to blow down the sediments collected at the bottom of the drum or to empty the boiler or to lower down the water level in the drum. The blow-off cock is fitted at the lowest portion of the boiler. The casing is provided with two flanges, one is connected to the boiler and the other is connected to the steam pipe. The plug valve has a hole. When it is desired to discharge the water, the plug valve is turned in a manner so that the hole in the plug can align with the hole in casing and water can rush out of the boiler. The flow of water can be stopped by turning the plug such that its solid part comes in line with the hole in the casing. The constructional details are shown in Figure 4.22.

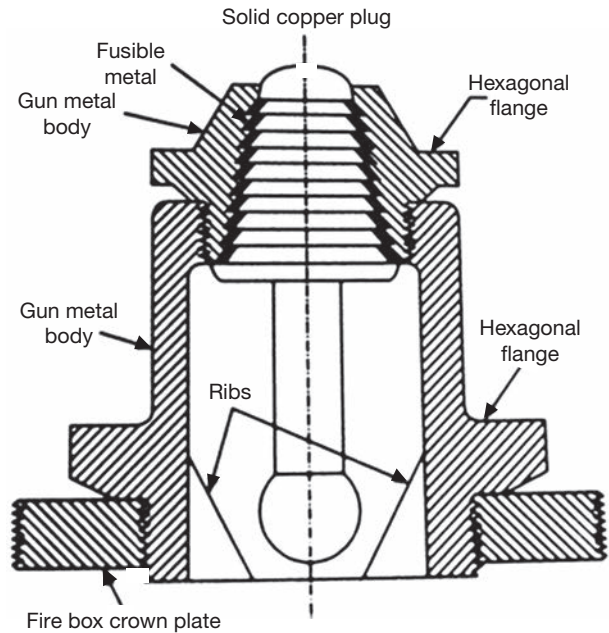


**FIGURE 4.22**

Blow-off Cock

### 4.8.8 Fusible Plug

The function of the fusible plug is to extinguish the fire in the fire box when the water level in the boiler comes down the limit. It prevents from blasting the boiler, melting the tube and overheating the firebox crown plate. The constructional details of the fusible plug are shown in Figure 4.23. It is located in the water space of the boiler. The fusible metal is protected from direct contact with water by Gunmetal and Copper plug. When water level comes down, the fusible metal melts due to high heat and copper plug drops down and holds in gun metal ribs. Steam comes in contact with fire and distinguishes it. Thus, it prevents from damages.



**FIGURE 4.23**

Fusible Plug

### 4.8.9 Manhole

This is opening in the boiler. It is used for cleaning and inspection purpose. Through this hole, the operator enters the boiler in idle condition.

## 4.9 ► BOILER ACCESSORIES

The devices used in a boiler to increase its efficiency and quality of steam are known as accessories. The names of some important accessories are mentioned below:

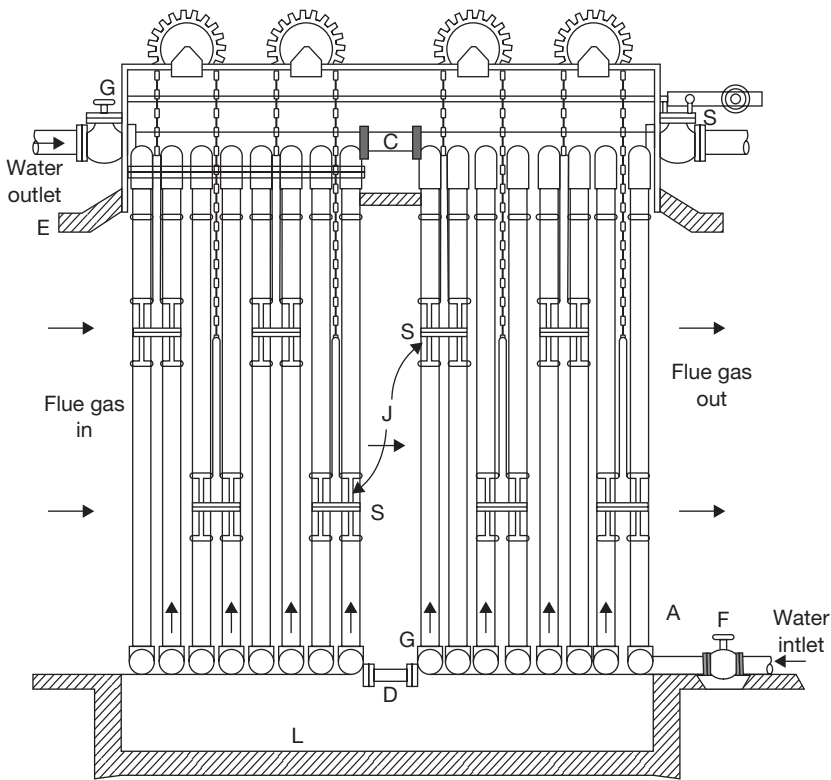
1. Economizer,
2. Air preheater,
3. Super heater,
4. Steam trap,
5. Steam separator,
6. Injector.

### 4.9.1 Economizer

Economizer is a type of heat exchanger which exchanges some parts of the waste heat of flue gas to the feed water. It is installed between the exit of the furnace and entry into the chimney. Generally, the economizer is placed after feed pump to avoid the problem of priming in feed pump. If the economizer is installed before feed pump, some amount of water may be transformed into vapor, which can create a priming problem in feed pump. In this case, limit of temperature rise of water is fixed so that water cannot be transformed into steam. The constructional details of economizer are shown in Figure 4.24. It consists of vertical cast iron tubes attached with scrapers. The function of the scraper is to remove the soot deposited on the tube. Water flows through the tube to the boiler drum. These tubes are arranged in the path of the waste flue gas entering into the chimney. The flow of water is controlled by two valves attached to down header and up the header of the tubes. The waste heat of the flue gas is transferred to the tube material and then tube material to water.

#### *Advantages*

- (i) It increases the power output of the plant. For a 6°C increase in temperature of water efficiency of boiler increases by 1%.
- (ii) It increases the evaporation capacity.
- (iii) It increases the life of boilers due to less thermal stress.



**FIGURE 4.24**

Economizer

### 4.9.2 Air Preheater

Air preheater is a device for recovery of waste heat from flue gas and is placed in the path of the waste flue gas going to the chimney. Waste heat of the flue gas is transferred to the air before its use to support economical combustion in a furnace. It is placed in the chimney and above economizer. If fuels used in the furnace are oil, gasses, or pulverized coal, the hot air supply is possible. But, in the case of stoker firing, the maximum temperature of the air is limited due to overheating of stoker parts. The constructional details of an air preheater are shown in Figure 4.25.

#### Advantages

- (i) Due to high furnace temperature, water evaporation rate increases.
- (ii) Boiler efficiency increases by 2 to 10%.
- (iii) Low-grade fuel can be used.

### Disadvantages

Capital cost increases due to use of pre-heater and two fans (induced fan and forced draught fan) to create an artificial draught.

### 4.9.3 Superheater

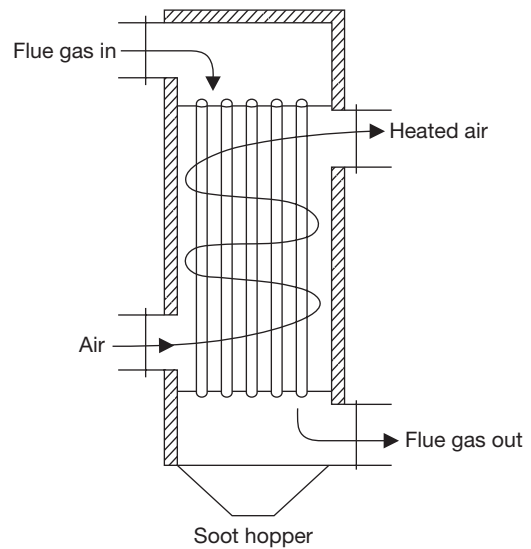
Steam generated in the boiler is wet due to contact with water. To get superheated steam, a device known as superheater is used in the boilers. The function of superheater is to superheat the steam up to the desired level. It is a surface heat exchanger, located in the path of the flue gas. The wet steam flows inside the tube and hot flue gas passed over the tubes. Constructional details of a superheater are shown in Figure 4.26.

### Advantages

- (i) Superheater increases the efficiency of prime movers due to the supply of steam at high-temperature and pressure.
- (ii) It minimizes the condensation loss in a prime mover.
- (iii) It eliminates the problems of erosion and corrosion in turbine blades.
- (iv) It increases the capacity of the plant.
- (v) It reduces the friction of the steam in a steam engine and other steam parts.

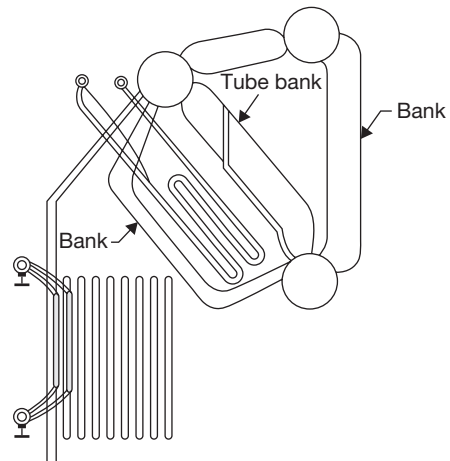
### 4.9.4 Feed Pump

The function of feed pump is to feed the water to the boiler. Different types of feed pumps used in boilers are reciprocating, centrifugal, and injector. Centrifugal or rotary pumps are used where a large amount of water is required. For small boilers, reciprocating pump and injectors are used.



**FIGURE 4.25**

Air Preheater



**FIGURE 4.26**

Superheater



### 4.9.5 Injector

The injector is a feed pump which is used to deliver feed water into the boiler under pressure. It is mostly used in vertical and locomotive boilers. It is not suitable for large power plants. It consists of a group of nozzles so arranged that the steam expanding in these nozzles imparts kinetic energy to a mass of water. The constructional details of the injector are shown in Figure 4.27.

#### Advantages

- (i) It requires minimum space.
- (ii) Maintenance cost is low.
- (iii) The initial cost of installation is low.
- (iv) It is thermally more efficient than feed pump.

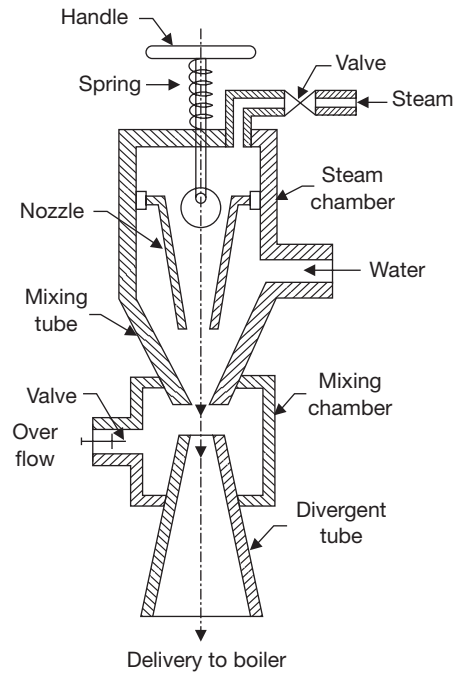
### 4.9.6 Steam Trap

The function of a steam trap is to drain the water condensed due to partial condensation and jacket without allowing the steam to escape through it.

### 4.9.7 Steam Separator

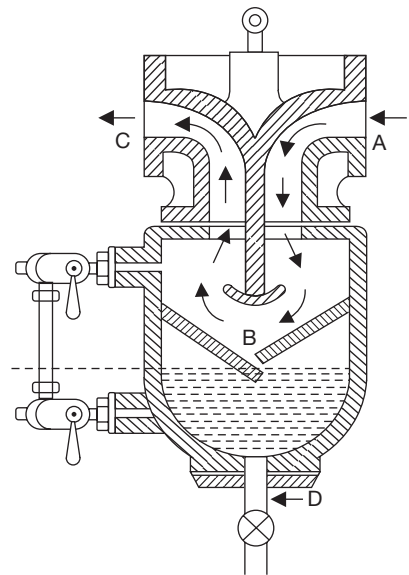
The function of a steam separator is to separate the suspended water particles carried by steam on its way from the boiler to the engine of the turbine. It is installed in the mainstream pipe very near to the engine. The constructional details are shown in Figure 4.28.

The steam from the boiler enters the steam separator through a flange and moves down. During its passage down, it strikes the baffles and is deflected upward. The steam on striking the baffles causes the particles having the higher density to fall to the bottom of the separator with high inertia. Dry steam deflected up and comes out through the flange B. The separated water is collected at the bottom, which is drained out by drain cock and drain pipe.



**FIGURE 4.27**

Steam Injector

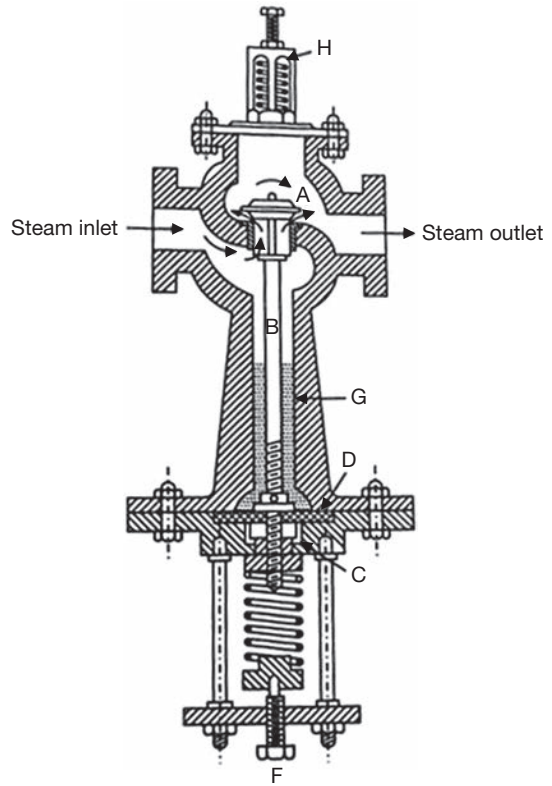


**FIGURE 4.28**

Steam Separator

### 4.9.8 Pressure Reducing Valve

The function of the pressure reducing valve is to maintain constant pressure on its delivery side of the valve irrespective of fluctuating demand of steam. This is achieved by throttling of steam passing through the pressure reducing valve. It is generally used in low capacity boilers where it is difficult to maintain constant delivery pressure with fluctuating demand of steam. In such a boiler, steam is generated at a higher pressure than the required by prime movers. The constructional details are shown in Figure 4.29. From boiler, high-pressure steam enters the steam inlet flange via throttle valve A to steam outlet flange. The throttling is done by a spring and valve rod mechanism. When the steam passes through the throttle valve, its pressure reduces. The force exerted by spring can be adjusted by a screw F. This varies the opening of the throttle valve so that any exit pressure required can be manipulated.



**FIGURE 4.29**

Pressure Reducing Valve

## 4.10 ► PERFORMANCE OF BOILERS

**Evaporation Rate:** it is the steam generation rate of boilers which may be expressed in terms of kg of steam per unit heating surface area or kg of steam per cubic meter of furnace volume or kg of steam per kg fuel burnt.

**Equivalent Evaporation:** It is equivalent of evaporation of 1 kg of water at 100°C to dry and saturated steam at 100°C, the standard atmospheric pressure of 1.013 bar. Hence, the equivalent evaporation of 1 kg of water at 100°C needs 2257 kJ.

**Factor of Evaporation:** It is the ratio of heat absorbed by 1 kg of feed water under working conditions to the latent heat of steam at atmospheric pressure.

$$F = \frac{h_s - h_w}{2257 \text{ kJ}}; \quad \text{where } h_s = h_f + x.h_{fg}$$

**Boiler Efficiency:** It is the ratio of heat absorbed by water in the boiler to heat supplied to boiler per unit time.

$$\eta_{\text{boiler}} = \frac{m_w (h_s - h_w)}{m_f \times CV}; \quad \text{where CV is calorific value of fuel}$$

### EXAMPLE 4.12

In a boiler trial observations made are as:

Feed water temperature = 40°C

Boiler pressure = 15 bar

Dryness fraction of steam = 0.85

Coal consumption = 450 kg/h

Feed water supplied = 3,500 kg/h

Calorific value of coal = 40,000 kJ/kg

Calculate the evaporation factor and equivalent evaporation at 100°C in kg/kg of coal.

Specific heat of feed water = 4.18 kJ/kgK.

### SOLUTION

At 15 bar, (from steam table)

$$h_f = 844.89 \text{ kJ/kg}; \quad h_{fg} = 1947.3 \text{ kJ/kg}$$

At 40°C,  $h_w = 167 \text{ kJ/kg}$

$$\text{Actual evaporation rate per kg of coal, } m_a = \frac{3500 \text{ kg/hr}}{450 \text{ kg/hr}} = 7.77 \text{ kg/kg of coal}$$

$$\begin{aligned} \text{Evaporation equivalent, } m_e &= \left\{ \frac{(h_f + xh_{fg}) - h_w}{2257} \right\} \times m_a \\ &= \left\{ \frac{(844.89 \text{ kJ/kg} + 0.85 \times 1947.3 \text{ kJ/kg}) - 167.57 \text{ kJ/kg}}{2257 \text{ kJ}} \right\} \times 7.77 \\ &= \mathbf{8.03 \text{ kg / kg of coal}} \end{aligned}$$

$$\begin{aligned} \text{Evaporation factor, } F &= \frac{(844.89 \text{ kJ / kg} + 0.85 \times 1947.3 \text{ kJ / kg}) - 167.57 \text{ kJ/kg}}{2257 \text{ kJ}} \\ &= \mathbf{1.033} \end{aligned}$$

**EXAMPLE 4.13**

In a boiler observations made were as:

- Rate of feed water per hour = 1,000 kg
- Temperature of feed water = 30°C
- Steam pressure = 10 bar
- Quality of steam = 0.9
- Coal consumption rate per hour = 100 kg
- Calorific value of coal = 33,000 kJ/kg
- Mass of ash and unburnt coal = 10 kg/h
- Calorific value of ash and unburnt coal = 3,000 kJ/kg
- Quantity of flue gas/kg of coal = 20 kg
- Discharged gas temperature = 300°C
- Atmospheric temperature = 20°C
- Specific heat of flue gas = 1.03 kJ/kgK

Calculate:

- (a) boiler efficiency
- (b) percentage of heat loss in flue gas
- (c) percentage of heat loss to ash and unburnt coal
- (d) percentage of heat loss unaccounted for.

**SOLUTION**

From steam table. At 10 bar,

$$h_f = 762 \text{ kJ/kg}; \quad h_{fg} = 2,015.3 \text{ kJ/kg}$$

Enthalpy of feed water at 30°C,  $h_w = 125.79 \text{ kJ/kg}$

$$\begin{aligned} \text{(a) } \eta_{\text{boiler}} &= \frac{(h_f + xh_{fg} - h_w) \times \text{Steam in kg per hour}}{\text{Calorific value} \times \text{coal in kg per hour}} \times 100 \\ &= \frac{(762 \text{ kJ/kg} + 0.9 \times 2015.3 \text{ kJ/kg} - 125.79 \text{ kJ/kg}) \times 1000 \text{ kg/hour}}{33000 \text{ kJ/kg} \times 100 \text{ kg/hour}} \times 100 \\ &= 74.24\% \end{aligned}$$

$$(b) \text{ Heat carried away by flue gas, } Q = m_f C_f (t_f - t_a) = 20 \text{ kg} \times 1.03 \text{ kJ/kg} (300^\circ\text{C} - 20^\circ\text{C}) \\ = 5768 \text{ kJ/kg of coal}$$

$$\text{hence, loss} = \frac{5768 \text{ kJ/kg}}{33000 \text{ kJ/kg}} = 17.47\%$$

$$(c) \text{ Quantity of ash and unburnt coal} = 10 \text{ kg/hour}$$

$$\text{Heat lost in ash and unburnt coal} = \frac{10 \text{ kg/hour} \times 3000 \text{ kJ/kg}}{33000 \text{ kJ/kg} \times 100 \text{ kg/hour}} = 0.009 = 0.9\%$$

$$(d) \text{ Total heat accounted for} = 74.24\% + 17.47\% + 0.9\% = 92.61\%$$

$$\text{Heat unaccounted for} = (100 - 92.61\%) = 7.39\%$$

### EXAMPLE 4.14

A boiler plant delivers steam at 20 bar and  $360^\circ\text{C}$  to an engine developing 1,350 kW at the rate of 10 kg/kWh. Temperature of feed water =  $80^\circ\text{C}$ . Calorific value of fuel = 28,000 kJ/kg. The grate is to be designed to burn 400 kg of coal per  $\text{m}^2$  per hour. Find the grate area required for the above duty, assuming the combustion efficiency of 90% and boiler efficiency including superheater as 75%.

### SOLUTION

Enthalpy of steam at 20 bar and  $360^\circ\text{C}$  (from steam table),

$$h_g = 3,159 \text{ kJ/kg (use interpolation)}$$

$$h_f = \text{Enthalpy of feed water at } 80^\circ\text{C} = 334.91 \text{ kJ/kg}$$

$$\text{Mass of steam required to produce, 350 kW power} = 1,350 \times 10 \\ = 13,500 \text{ kg/h}$$

$$\text{Heat required} = 13,500 \text{ kg/hr} (h_g - h_f) = 13,500 \text{ kg/hr} (3,159 \text{ kJ/kg} - 334.91 \text{ kJ/kg}) \\ = 38,125.215 \times 10^3 \text{ kJ}$$

$$\text{Calorific value of fuel} = 28,000 \text{ kJ/kg}$$

But, combustion efficiency given as 90%

$$\therefore \text{ Actual calorific value} = 28,000 \text{ kJ/kg} \times 0.9 = 25,200 \text{ kJ/kg}$$

$$\text{Boiler efficiency} = 0.75 = \frac{3812521}{m_f \times CV} \Rightarrow m_f = \frac{3812521 \text{ kJ/hr}}{0.75 \times 25200 \text{ kJ/kg}} = 201.72 \text{ kg/hr}$$

$$\text{Area of grate required} = \frac{201.72 \text{ kg/hr}}{400 \text{ kg/hr.m}^2} = 0.504 \text{ m}^2$$



## RECAP ZONE .....

### Points to Remember

- **Steam** is a gaseous form of water.
- At very high pressure, latent heat of vaporization becomes zero, which is known as the **critical point**.
- Wet steam contains partly water as suspended in it and partly steam.
- **Dryness fraction** is defined as the mass of dry steam per kg of wet steam. It is represented by  $x$ .
- The properties of steam are pressure, temperature, volume, enthalpy, entropy, internal energy. These values are determined experimentally and tabulated as a steam table.
- Separate steam tables for saturated and superheated are used.
- **Mollier diagram** is a graph between enthalpy and entropy. Various properties of steam can be shown graphically on this diagram.
- **Throttling calorimeter** is a device used in the determination of the dryness fraction of steam. Wet steam is superheated using throttling process. To know the dryness fraction the enthalpy is balanced before and after throttling.
- **Separating calorimeter** is used to measure the dryness fraction by using the separation of water particle from the steam.
- In this process, the dryness fraction of the separated steam is very less compared to throttling calorimeter. Therefore, a combined device, i.e., separating and throttling calorimeter is used.
- In **separating and throttling calorimeter**, the separated steam is dried using throttling process.
- A combination of apparatus for producing, furnishing or recovering heat together with apparatus for transferring the heat so made available to water which would be heated and vaporized to steam form.
- In **fire tube boilers**, flue gas passes through the tube and the heat of the flue gas is absorbed by the tube and transferred to the water surrounding the tube.
- In **water tube boilers**, water flows inside the tube and the tube is kept in the path of flow of flue gas.
- In an **internal fired boiler**, firing takes place inside the boiler drum, i.e., furnace is located inside the drum.
- In an **external fired boiler**, the furnace is outside the boiler drum and water is circulated inside the tube passing through the furnace.
- **Low-pressure boilers** operate below 80 bar; high-pressure boilers operate above 80 bar; and supercritical boilers operate at 221 bar and above.
- In **natural circulation boilers**, water circulates automatically due to the pressure difference created by the temperature difference.
- In **forced circulated boilers**, pumps are used to circulate the water through tubes.
- **Cochran boiler** is fire tube, multitubular, internal fired and vertical boiler.
- **Babcock and Wilcox boiler** is a water tube, horizontal, multitubular, external fired boiler.
- **Locomotive boiler** is a fire tube, horizontal, multitubular, natural circulation, movable, artificial draught, internally fired boiler.
- A **Lancashire boiler** is horizontal, fire tube, internal fired, natural circulation type boiler. There are two fire tubes.
- **Cornish boiler** is similar to Lancashire boiler, but the number of the tube is only one.
- **Safety valve** is used to release the excess pressure inside the boiler drum.
- In a dead weight safety valve, the steam pressure acting in an upward direction is counterbalanced by the dead weight of safety valve acting in the downward direction.

- In a spring loaded safety valve, spring force works against the steam pressure, when the steam pressure becomes high, valve lifted off the valve seat and steam is escaped out.
- Lever safety valve works on the principle of the second system of the lever.
- The functions of high steam and low water safety valve are:
  - (a) To blow out steam if steam pressure becomes higher than the working pressure.
  - (b) To blow out steam when the water level in the boiler comes down.
- The function of the **water level indicator** is to show the water level inside the boiler drum.
- **Pressure gauge** is used to measure the pressure inside the boiler drum.
- The function of **feed check valve** is to allow the flow of water under pressure from the feed pump to the boiler and to prevent the backflow of water in case of failure of the feed pump.
- The function of **steam stop valve** is to stop or allow the flow of steam from the boiler to steam pipe or from the steam pipe to supply.
- The function of the **blow-off cock** is to blow down the sediments collected at the bottom of the drum or to empty the boiler or to lower down the water level in the drum.
- The function of the **fusible plug** is to extinguish the fire in the fire box when the water level in the boiler comes down the limit.
- A **manhole** is used for cleaning and inspection purpose.
- **Economizer** is a type of heat exchanger, which exchanges some parts of the waste heat of flue gas to the feed water.
- **Air preheater** is a device for recovery of waste heat from flue gas and is placed in the path of the waste flue gas going to the chimney.
- The function of **superheater** is to superheat the steam up to the desired level.
- The function of **feed pump** is to feed, the feed water to the boiler.
- The injector is a feed pump, which is used to deliver feed water into the boiler under pressure.
- The function of a **steam trap** is to drain the water condensed due to partial condensation and jacket without allowing the steam to escape through it.
- The function of a steam separator is to separate the suspended water particles carried by steam on its way from the boiler to the engine of the turbine.
- The function of the pressure reducing valve is to maintain constant pressure on its delivery side of the valve irrespective of fluctuating demand of steam.
- **Draught** is a small pressure difference causing the flow of flue gas and air through the boilers.
- **Natural draught** is a pressure difference of the hot gasses column inside the chimney and cold air column of the same height outside the chimney.
- If a **mechanical induced fan** is used at the base of the chimney to suck the air and flue gasses from the furnace, the draught created is known as induced draught.
- If a mechanical fan is installed at the gate of the furnace to force the air inside the furnace, the draught created is known as forced draught.
- If both forced draught and induced draught fans are used in a boiler, the draught created is known as balance draught.
- **Evaporation rate** is the steam generation rate of boilers, which may be expressed in terms of kg of steam per unit heating surface area or kg of steam per cubic meter of furnace volume or kg of steam per kg fuel burnt.
- **Equivalent evaporation** is equivalent of evaporation of 1 kg of water at 100°C to dry and saturated steam at 100°C, the standard atmospheric pressure of 1.013 bar.
- **Factor of evaporation** is the ratio of heat absorbed by 1 kg of feed water under working conditions to the latent heat of steam at atmospheric pressure.
- **Boiler efficiency** is the ratio of heat absorbed by water in the boiler to heat supplied to boiler per unit time.

## Important Formulae

$$1. \quad h_{fg} = h_g - h_f = (u_g - u_f) + P(V_g - V_f) \text{ kJ / kg}$$

$$2. \quad x = \frac{m_g}{m_g + m_f}$$

$$3. \quad h = xh_g + (1-x)h_f = h_f + xh_{fg}$$

$$4. \quad V = xV_g + (1-x)V_f = V_f + xV_{fg}$$

$$5. \quad u_f = h_f - P_f V_f$$

$$u_g = h_g - P_g V_g$$

$$6. \quad \Delta S = S_2 - S_1 = \int_{T_1}^{T_2} \frac{C_p dT}{T} = C_p \log_e \frac{T_2}{T_1}; \quad \text{at constant pressure}$$

$$7. \quad S = S_f + S_{fg} = C_p \log_e \frac{T_s}{T_0} + \frac{h_{fg}}{T_s} \text{ for dry saturated steam at constant pressure } (x = 1)$$

$$S = S_f + xS_{fg} = C_p \log_e \frac{T_s}{T_0} + \frac{xh_{fg}}{T_s} \text{ for wet steam at constant pressure}$$

$$S = S_f + xS_{fg} + S_g = C_{pw} \log_e \frac{T_s}{T_0} + \frac{xh_{fg}}{T_s} + C_p \log_e \frac{T_{sup}}{T_s} \text{ for superheated steam at constant pressure}$$

where  $C_{pw} \approx 1$ , specific heat of water.

$$x_1 = \frac{h_{g2} + C_p (t_{sup} - t_{s2}) - h_{f1}}{h_{fg}}; \text{ where } C_p = 0.48$$

## REVIEW ZONE .....



### Multiple-choice Questions

1. Device used to generate and supply steam at a high pressure and temperature is known as:
  - (a) Steam injector
  - (b) Steam boiler
  - (c) Steam turbine
  - (d) Steam condenser
2. Fire tube boilers are:
  - (a) Internally fired
  - (b) Externally fired
  - (c) Both
  - (d) None of the above
3. Fire tube boilers are:
  - (a) Lancashire boiler
  - (b) Cochran boiler
  - (c) Locomotive boiler
  - (d) All of the above
4. Number of fire tubes in Lancashire boiler are:
  - (a) 1
  - (b) 2
  - (c) 3
  - (d) 4
5. In a Lancashire boiler, the economizer is located:
  - (a) Before air preheater
  - (b) After air preheater
  - (c) Between the feed pump and drum
  - (d) All of the above
6. Locomotive boiler is:
  - (a) Vertical, multitubular, fire-tube type
  - (b) Horizontal, multitubular, fire-tube type
  - (c) Horizontal, multitubular, water-tube type
  - (d) None of the above
7. Water tube boiler is:
  - (a) Babcock and Wilcox boiler
  - (b) Stirling boiler
  - (c) Benson boiler
  - (d) All of the above
8. Babcock and Wilcox boiler has water tubes:
  - (a) Vertical
  - (b) Horizontal
  - (c) Inclined
  - (d) None of the above



9. If circulation of water takes place by convection currents, set up during the heating of water, the boiler is known as:
  - (a) Natural circulation boiler
  - (b) Forced circulation boiler
  - (c) Internally fired boiler
  - (d) Externally fired boiler
10. If circulation in boiler made by pump, then it is known as:
  - (a) Natural circulation boiler
  - (b) Forced circulation boiler
  - (c) Internally fired boiler
  - (d) Externally fired boiler
11. If combustion takes place outside the boiling water region, the boiler is known as:
  - (a) Natural circulation boiler
  - (b) Forced circulation boiler
  - (c) Internally fired boiler
  - (d) Externally fired boiler
12. If combustion takes place inside the boiling water region, the boiler is known as:
  - (a) Natural circulation boiler
  - (b) Forced circulation boiler
  - (c) Internally fired boiler
  - (d) Externally fired boiler
13. In forced circulation boiler, forced is applied to:
  - (a) Draw water
  - (b) Drain off the water
  - (c) Circulate water
  - (d) All of the above
14. Forced circulation boiler is:
  - (a) La-Mont boiler
  - (b) Benson boiler
  - (c) Loeffler boiler
  - (d) All of the above
15. Safety Valve used in locomotive boilers is:
  - (a) Lever safety valve
  - (b) Dead weight safety valve
  - (c) High steam and low water safety valve
  - (d) Spring loaded safety valve
16. A device used to empty the boiler, when required and to discharge the mud, scale or sediments collected at the bottom of the boiler, is known as:
  - (a) Safety valve
  - (b) Stop valve
  - (c) Fusible plug
  - (d) Blow off cock
17. An accessory of boiler is:
  - (a) Feed pump
  - (b) Feed check valve
  - (c) Stop valve
  - (d) Blow off cock
18. A device used for recovery of waste heat of flue gas to heat the air before it passes into the furnace is known as:
  - (a) Superheater
  - (b) Air preheater
  - (c) Injector
  - (d) Economizer
19. Boiler mounting is:
  - (a) Economizer
  - (b) Injector
  - (c) Fusible plug
  - (d) Super heater
20. Ratio of heat used in steam generation and heat supplied to the boiler is known as:
  - (a) Boiler efficiency
  - (b) Chimney efficiency
  - (c) Economizer efficiency
  - (d) None of the above
21. At very low-temperature at which melting and boiling point of water becomes equal is:
  - (a) 233 K
  - (b) 273.16 K
  - (c) 303 k
  - (d) 0 K
22. The critical pressure at which latent heat of vaporization of water becomes zero is:
  - (a) 225.65 bar
  - (b) 273 bar
  - (c) 100 bar
  - (d) 1 bar
23. For water, below the atmospheric pressure:
  - (a) Melting point rises slowly and boiling point drops markedly
  - (b) Melting point drops slowly and boiling point rises markedly
  - (c) Melting point rises slowly and boiling point rises markedly
  - (d) None of these
24. The latent heat of steam at pressure greater than atmospheric pressure than that at atmospheric pressure is:
  - (a) Less
  - (b) More
  - (c) Equal
  - (d) None of these
25. The saturation temperature of steam with increasing in pressure increases:
  - (a) Linearly
  - (b) First rapidly then slowly
  - (c) Inversely
  - (d) None of these
26. Heating of dry steam above saturation temperature is known as:
  - (a) Enthalpy
  - (b) Superheating
  - (c) Supersaturating
  - (d) None of these
27. Superheating of steam is done at:
  - (a) Constant volume
  - (b) Constant pressure
  - (c) Constant enthalpy
  - (d) Constant entropy
28. The specific volume of steam with increase in pressure decreases:
  - (a) Linearly
  - (b) Slowly first and then rapidly
  - (c) Rapidly first and then slowly
  - (d) Inversely

29. If  $x_1$  and  $x_2$  be the dryness fractions obtained in separating calorimeter and throttling calorimeter respectively, then the actual dryness fraction of steam will be:  
 (a)  $x_1 x_2$  (b)  $x_1 + x_2$   
 (c)  $(x_1 + x_2)/2$  (d)  $x_1/x_2$
30. The specific heat of superheated steam in kCal/kg is generally of the order of:  
 (a) 0.1 (b) 0.3  
 (c) 0.5 (d) 0.8
31. A wet steam can be completely specified by:  
 (a) Pressure only  
 (b) Temperature only  
 (c) Dryness fraction only  
 (d) Pressure and dryness fraction
32. On Mollier chart, the constant pressure lines:  
 (a) Diverge from left to right  
 (b) Diverge from right to left  
 (c) First, rise up and then fall  
 (d) None of these
33. On Mollier diagram, free expansion, or throttling process from high pressure to the atmosphere is represented by:  
 (a) Horizontal straight line  
 (b) Vertical straight line  
 (c) Curved line  
 (d) None of these
34. Latent heat of dry steam at atmospheric pressure is equal to:  
 (a) 539 kCal/kg (b) 539 kJ/kg  
 (c) 539 BTU/lb (d) None of these
35. In throttling process:  
 (a) Entropy remains constant  
 (b) Enthalpy remains constant  
 (c) Pressure remains constant  
 (d) None of these

## Fill in the Blanks

36. Water tube boilers produce steam at a \_\_\_\_\_ pressure than that of fire tube boilers.
37. For same dimensions and thickness of the tube, a water tube boiler has \_\_\_\_\_ heating surface than a fire tube boiler.
38. A \_\_\_\_\_ in a boiler is used to put off a fire in the furnace when the level of water falls to the unsafe limit.
39. An equivalent evaporation of a boiler is defined as \_\_\_\_\_.
40. The draught in the locomotive boiler is produced by \_\_\_\_\_.

## Answers

- |            |          |                  |         |         |         |
|------------|----------|------------------|---------|---------|---------|
| 1. (b)     | 2. (c)   | 3. (d)           | 4. (b)  | 5. (b)  | 6. (b)  |
| 7. (d)     | 8. (c)   | 9. (a)           | 10. (b) | 11. (d) | 12. (c) |
| 13. (c)    | 14. (d)  | 15. (d)          | 16. (d) | 17. (a) | 18. (b) |
| 19. (c)    | 20. (a)  | 21. (b)          | 22. (a) | 23. (a) | 24. (a) |
| 25. (b)    | 26. (b)  | 27. (b)          | 28. (c) | 29. (a) | 30. (c) |
| 31. (d)    | 32. (a)  | 33. (a)          | 34. (a) | 35. (b) |         |
| 36. Higher | 37. More | 38. Fusible plug |         |         |         |

39. The amount of water evaporated from and at 100°C to dry and saturated steam

40. Passing the steam through the furnace

## Theory Questions

- \*1. Define dryness fraction and degree of superheat and show their applications in a steam power plant.
2. Explain the use of steam table and Mollier diagram.
- \*3. Draw a neat sketch of throttling calorimeter and explain how dryness fraction of steam is determined. What are its limitations?
4. What are requirements of a good boiler?
5. Differentiate between (i) Natural circulation and forced circulation in boilers, (ii) Internal fired and external fired boilers, (iii) Fire tube and water tube boilers, and (iv) High-pressure and low-pressure boilers.
6. Explain very briefly the function of following mountings:
  - (i) Steam stop valve
  - (ii) Feed check valve
  - (iii) Blow-off cock
  - (iv) water level indicator
  - (v) Pressure gauge
  - (vi) Safety valve
7. State the advantages of high-pressure boilers. Explain the construction and working of Babcock and Wilcox boiler with a neat sketch.
8. Explain the construction and working of a pressure gauge with a neat sketch.
9. Explain the working of Cochran boiler and fusible plug with neat sketches.
- \*10. State the function of following:
  - (i) Fusible plug
  - (ii) Safety valve
  - (iii) Economizer
- \*11. What is boiler? Discuss Construction and working of Cochran boiler with neat sketch.
- \*12. Write a short note on Separating calorimeter with its limitations.
- \*13. Define boiler according to IBR. Classify mountings into safety fittings and control fittings.
- \*14. Describe the functions of chimney in a boiler.
- \*15. Name all the mountings and accessories of a steam boiler and describe, with neat sketch, the working of any one of each.
- \*16. Explain economizer and air-preheater with neat sketch.
- \*17. Show the function and location of the following in the boiler plant:
  - (i) Feed check valve
  - (ii) Air superheater, and
  - (iii) Fusible plug.
- \*18. Enumerate the advantages and disadvantages of superheated steam.
- \*19. Explain briefly air preheater, superheater, and chimney with respect to boilers.
- \*20. Explain with neat sketch and working principle of Lancashire boiler.

## Numerical Problems

1. A pressure cooker contains  $0.5 \text{ m}^3$  water and water vapor mixture at  $300^\circ\text{C}$ . Calculate the mass of each if their volumes are equal.
2. Steam flows through a pipe at the rate of  $5 \text{ kg/s}$ . The pressure and temperature are  $12 \text{ bar}$  and  $300^\circ\text{C}$ , respectively. If  $2,000 \text{ kJ}$  of heat is lost to the surroundings at constant pressure. Find the final condition of steam.
3. A container is filled with a saturated steam at  $12 \text{ bar}$ . The volume of the container is  $1 \text{ m}^3$ . First, the container is evacuated, then necessary amount of water is filled and evaporated by heating:
  - (a) What mass of water is required and what will be the temperature of water.
  - (b) If the container, finally, contains a two-phase system with a dryness fraction of  $85\%$ . What will be the required mass?

\* indicates that similar questions have appeared in various university examinations.

4. 10 kg of wet steam of quality 0.8 at 5 bar pressure is heated at constant pressure till the temperature rise is  $500^{\circ}\text{C}$ . Calculate the amount of energy added as heat.
5. A boiler of volume  $1\text{ m}^3$  contains wet steam of quality 0.85 at 10 bar. The inlet and outlet valves of the boiler are closed and energy addition as heat is stopped. After some time, the pressure of steam is found 4 bars. Determine:
- the mass of liquid and vapor in boiler initially,
  - the mass of liquid and vapor in the boiler at the end, and
  - energy lost to the surrounding as a heat.
6. A pressure cooker contains 10 kg of saturated steam at 8 bar. Find the quantity of heat which must be rejected to reduce the quality to 85%. Determine the pressure and temperature at the new state.
7. Determine the enthalpy and internal energy of 1 kg steam at a pressure of 10 bar, when (i) the dryness fraction of steam is 0.85, (ii) the steam is superheated to  $300^{\circ}\text{C}$ , and (iii) when steam is dry and saturated. Neglect the volume of water and take the specific heat of superheated steam as  $2.1\text{ kJ/kgK}$ .
8. Determine dryness fraction of steam supplied to a separating and throttling calorimeter.  
 Water separated in separating calorimeter = 0.45 kg  
 Steam discharged from throttling calorimeter = 7 kg  
 Steam pressure in the main pipe = 1.2 MPa  
 Barometer reading = 760 mm of Hg  
 Manometer reading = 180 mm of Hg  
 Temperature of steam after throttling =  $140^{\circ}\text{C}$ ;  
 $C_p = 2.1\text{ kJ/kgK}$
9. A steam generator evaporates 17,000 kg/h of steam at 14 bar and quality of 0.95 from feed water at  $102^{\circ}\text{C}$ . When coal is fired at the rate of 2,050 kg/h having a calorific value of 27,400 kJ/kg. Assume the specific heat of water as  $4.187\text{ kJ/kgK}$ . Calculate: (i) Heat supplied per hour, (ii) Thermal efficiency, and (iii) Equivalent evaporation.
10. Determine dryness fraction of steam supplied to a separating and throttling calorimeter.  
 Water separated in separating calorimeter = 0.2 kg  
 Steam discharged from throttling calorimeter = 1.8 kg  
 Steam pressure in main pipe = 9 bar  
 Steam pressure after throttling = 1 bar  
 Temperature of steam after throttling =  $115^{\circ}\text{C}$ ;  
 $C_p = 2.1\text{ kJ/kgK}$
11. A boiler generates 7.5 kg of steam per kg of coal burnt at a pressure of 11 bar. The feed water temperature is  $70^{\circ}\text{C}$ ; boiler efficiency is 75%; factor of evaporation is 1.15;  $C_p = 2.1\text{ kJ/kgK}$ . Calculate: (i) degree of superheat and temperature of steam generated, (ii) calorific value of coal in kJ/kg, and (iii) equivalent evaporation in kg of steam per kg of coal.
12. What height of chimney is required to produce a draught of 20 mm of water column, if 15 kg of air is required to burn 1 kg of coal? The mean temperature of gas inside the chimney is  $300^{\circ}\text{C}$  and that of atmospheric air is  $35^{\circ}\text{C}$ .
13. Calculate the mass of air required to burn per kg of coal for chimney height of 40 mm. Draught produced is 24 mm of water. The temperature of flue gas inside the chimney is  $350^{\circ}\text{C}$  and that of the air outside the chimney is  $20^{\circ}\text{C}$ . Also, calculate the draught produced in term of hot flue gas column.
14. In a boiler observations made were as:  
 Rate of feed water per hour = 800 kg  
 Temperature of feed water =  $30^{\circ}\text{C}$   
 Steam pressure = 12 bar  
 Quality of steam = 0.95  
 Coal consumption rate per hour = 100 kg  
 Calorific value of coal = 32,000 kJ/kg  
 Mass of ash and unburnt coal = 10 kg/h.  
 Calorific value of ash and unburnt coal = 3,000 kJ/kg  
 Quantity of flue gas/kg of coal = 20 kg  
 Discharged gas temperature =  $350^{\circ}\text{C}$   
 Atmospheric temperature =  $25^{\circ}\text{C}$   
 Specific heat of flue gas =  $1.03\text{ kJ/kgK}$ .  
 Calculate:  
 (a) boiler efficiency  
 (b) percentage of heat loss in flue gas  
 (c) percentage of heat loss to ash and unburnt coal  
 (d) percentage of heat loss unaccounted for.

15. In a boiler trial observations made are as:  
 Feed water temperature = 30°C  
 Boiler pressure = 12 bar  
 Dryness fraction of steam = 0.80  
 Coal consumption = 400 kg/h  
 Feed water supplied = 3,000 kg/h  
 Calorific value of coal = 38,000 kJ/kg  
 Calculate the evaporation factor and equivalent evaporation at 100°C in kg/kg of coal. Specific heat of feed water = 4.18 kJ/kgK.
- \*16. How much heat is to be added to convert 4 kg of water at 20°C in to steam at 8 bar and 200°C. Take  $C_p$  of superheated steam as 2.1 KJ/kg and specific heat of water as 4.187 KJ/kg/K.
- \*17. What do you understand by mechanical and thermal efficiency? A steam plant uses 3 tonne of coal/h. The steam is fed to turbine the output of which is 4 MW. The calorific value of the coal is 30 MJ/kg calculate the thermal efficiency of the plant.
- \*18. Determine the quality of steam for the following cases:  
 (i)  $P = 10$  bar,  $v = 0.180$  m<sup>3</sup>/kg  
 (ii)  $P = 10$  bar,  $t = 200^\circ\text{C}$   
 (iii)  $P = 25$  bar,  $h = 2,750$  kJ/kg
- \*19. Combined separating and throttling calorimeter is used to find out dryness fraction of steam, following readings were taken:  
 Main pressure = 12 bar abs.  
 Mass of water collected in separating calorimeter = 2 kg.  
 Mass of steam condensed in throttling calorimeter = 20 kg  
 Temperature of steam after throttling calorimeter = 110°C  
 Pressure of steam after Throttling = 1 bar abs.  
 Assume  $C_p$  of steam = 2.1 kJ/kg K.  
 Calculate dryness fraction.
- \*20. Determine the quality of steam for the following cases:  
 (i)  $P = 10$  bar,  $v = 0.180$  m<sup>3</sup>/k  
 (ii)  $P = 10$  bar,  $t = 200^\circ\text{C}$   
 (iii)  $P = 25$  bar,  $h = 2,750$  kJ/kg
- \*21. Steam at 1,000 kPa and 300°C enters an engine and expands to 20 kPa. If the exhaust steam has a dryness fraction of 0.9, make calculations for the drop in enthalpy and change in entropy.
- \*22. Determine the total heat content per unit mass at the following state using the steam tables. Assume ambient pressure to be 100 kPa and  $C_p = 2.0934$  kJ/kg.  
 (i) 10 bar absolute and 300°C  
 (ii) 100 kPa gauge and 100 kPa abs and 250 L,C  
 (iii) Dry steam at 100 kPa abs  
 (iv) Steam at 12 bar and 95% dry
- \*23. Determine the specific volume and density of 1 kg steam at a pressure of  $7 \times 10^5$  Pa, when the condition of steam is: (i) Wet, having dryness fraction 0.9, (ii) Dry, and (iii) Superheated at 250°C. If required use the extract of the steam table provided below:
- | P     | $t_s$   | $V_g$                      |
|-------|---------|----------------------------|
| 7 bar | 437.92K | 0.27334 m <sup>3</sup> /kg |
- \*24. Determine enthalpy and internal energy of 1 kg of steam at a pressure of 12 bar when: (i) the dryness fraction of steam is 0.8, (ii) steam is dry and saturated, and (iii) steam is superheated to 2,800°C. Take  $C_{ps} = 2.1$  kJ/kg K.
- \*25. Calculate the internal energy per kg of superheated steam at 10 bar and a temperature of 300°C. Find, also change in internal energy if this steam is expanded to 1.4 bar and dryness fraction 0.8.

\* indicates that similar questions have appeared in various university examinations.

# Steam and Gas Turbines

## Learning Objectives

*By the end of this chapter, the student will be able:*

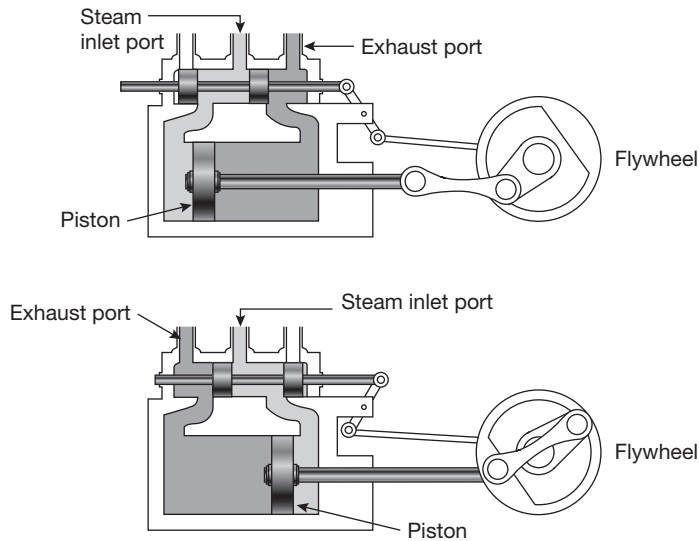
- To understand the utilization of heat energy of steam and flue gas in producing shaft/mechanical power
- To demonstrate the construction and working of steam and gas turbines
- To solve the design problems of steam and gas turbines
- To describe the principle of working of the Rankine and Jule cycle

### 5.1 ► INTRODUCTION

The steam power system is a system in which the heat energy of the steam is used to produce mechanical power. Various types of fuels (coal, diesel, natural gas, geothermal, nuclear, etc.) are used to produce the high quality of steam, i.e., superheated steam and then the thermodynamic expansion process is used to convert the heat energy of the steam into mechanical power. If mechanical power is developed in the form of shaft power and the shaft is coupled with electricity generator then the mechanical power is transformed into electrical energy. The steam engine was developed by James Watt in 1763 after that steam turbines, gas turbines, and I.C. Engines came into the picture.

### 5.2 ► STEAM ENGINE AND ITS WORKING PRINCIPLES

A steam engine is a reciprocating heat engine that performs mechanical work using steam as its working fluid. Steam engines are external combustion engines based on modified Rankine cycle, where the working fluid is separate from the combustion products. Water is heated into steam in a boiler until it reaches a high pressure and then expanded through pistons to do some mechanical work. The reduced-pressure steam is then released into the

**FIGURE 5.1**

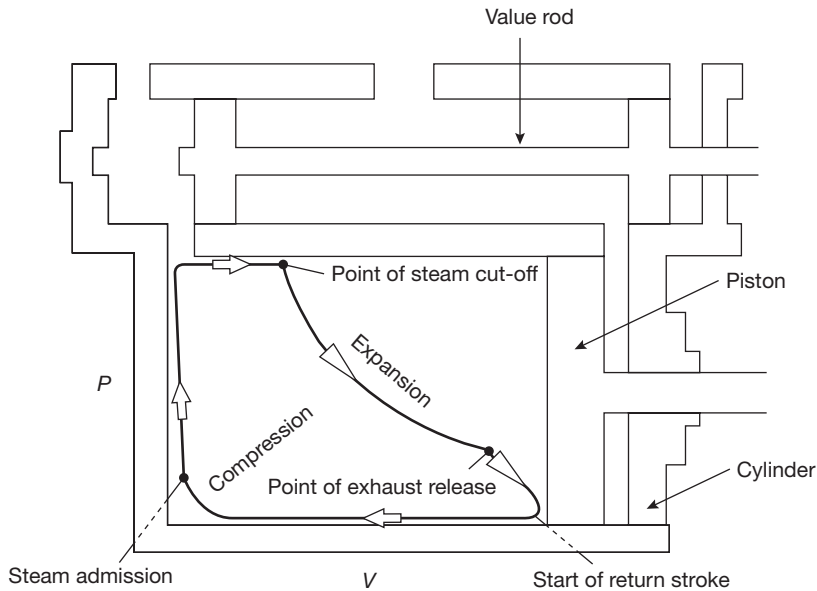
Working Principle of Steam Engine

atmosphere or condensed and pumped back into the boiler. The working of steam engine is shown in Figure 5.1.

In a steam engine, the movement of the valve ensures that steam is admitted to and exhausted from the cylinder at the right moment. For a typical cylinder that has two ports, i.e., double acting reciprocating steam engine, the function of the valve is to admit superheated steam at one end while allowing the exhaust steam to escape at the other. As a result of covering and uncovering these ports in sequence, the piston is pushed forward and backward by the high-pressure steam from the boiler. To regulate the movement of the valve, a mechanical valve gear system is used.

Lap refers to the amount of overlap between the valve and the port. In slow moving locomotives, the long lap on the exhaust port gives time for the steam trapped in the cylinder to expand fully to push the piston. On the other hand, on higher speed locomotives the exhaust port is made to open early (short lap) when the valve is in mid-position thus allowing the steam to escape faster. Higher speed locomotives also have a long lead, which means that the admission port is already open when the piston is at the end of its movement so there is a sufficient steam pressure that will immediately push the piston back to begin its next movement.

The indicator diagram such as shown in Figure 5.2 was used by steam locomotive engineers during the steam era to estimate the locomotive's efficiency in converting the steam's energy into useful power at various speeds and cut-offs. The horizontal line at the top of the

**FIGURE 5.2**

Modified Rankine Cycle

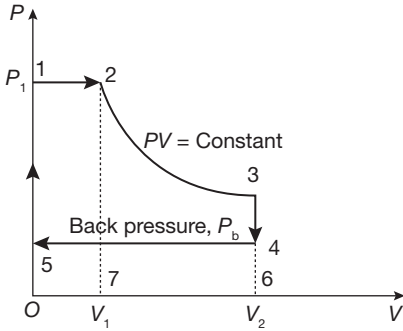
indicator diagram shows the pressure as the steam enters the cylinder. At cut-off, the pressure drops as the steam expands and does work to push against the piston. Cut-off denotes the position of the piston, at the moment the valve is closing the admission port. When the engine is working hard and slowly, long cut-off admits steam for most of the stroke of the piston. On fast running locomotives, this will cause back pressure to the boiler. To avoid unnecessary back pressure, the cut-off is reduced so that steam is admitted for only 20% of the piston stroke and the remainder of the stroke is due to the expansion of the high-pressure steam.

After the exhaust port opens, the horizontal line at the bottom of the indicator diagram indicates the return stroke of the piston. It shows the low pressure as the steam is exhausted. The curve at the end of the return stroke shows a pressure rise due to the compression of the remaining steam after the exhaust port has closed. As fresh steam is admitted into the cylinder, the pressure rises and the cycle repeats.

### 5.2.1 Modified Rankine Cycle: Theoretical Indicator Diagram

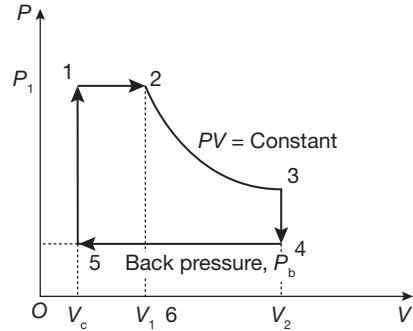
Theoretical indicator diagram of a steam engine is shown in Figure 5.3 without clearance volume and with clearance volume in Figure 5.4. In this diagram, clearance volume is zero. Steam at boiler pressure enters into the cylinder at the point 1 and cut-off at point 2. Then





**FIGURE 5.3**

Theoretical Indicator Diagram for Steam Engine



**FIGURE 5.4**

Theoretical Indicator Diagram of Steam Engine with Clearance Volume

the steam expands inside the cylinder isothermally from point 2 to point 3. Point 3 represents atmospheric pressure and the exhaust of the steam occurs at point 4, i.e., below the atmospheric pressure. Point 4 is known as the point of release. Exhaust occurs at constant pressure line 4-5. Again, steam enters into the cylinder at point 5 but suddenly the pressure increases to point 1.

$$\begin{aligned}
 \text{Work done per cycle} &= \text{Area of 12345} \\
 &= \text{Area of 1270} + \text{Area of 2367} - \text{Area of 4605} \\
 &= p_1 V_1 + p_1 V \log_e \frac{V_2}{V_1} - p_b V_2 \\
 &= p_1 V (1 + \log_e r) - p_b V_2 \quad \text{where } r \text{ is expansion ratio}
 \end{aligned}$$

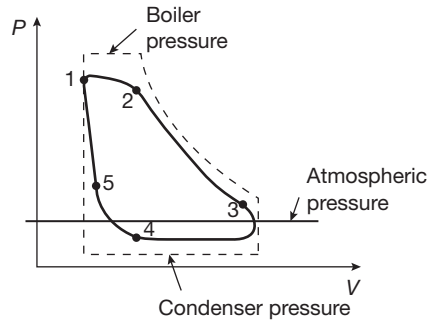
$$\begin{aligned}
 \text{Mean effective pressure} &= \frac{\text{Work done per cycle}}{V_2} \\
 &= \frac{p_1 V_1 (1 + \log_e r) - p_b V_2}{V_2} \\
 &= \frac{P_1}{r} (1 + \log_e r) - p_b
 \end{aligned}$$

Work done per cycle with clearance volume

$$\begin{aligned}
 &= p_1 V_1 + p_1 V \log_e \frac{V_2}{V_1} - p_b V_2 - (p_1 + p_b) V_c \\
 &= p_1 V (1 + \log_e r) - p_b V_2 - (p_1 + p_b) V_c \quad \text{where } r \text{ is expansion ratio}
 \end{aligned}$$

Mean effective pressure with clearance volume

$$\begin{aligned}
 &= \frac{\text{Work done per cycle}}{V_2 - V_c} \\
 &= \frac{p_1 V_1 (1 + \log_e r) - p_b V_2}{V_2 - V_c} \\
 &= \frac{\frac{P_1}{r} (1 + \log_e r) - p_b}{V_2 - V_c}
 \end{aligned}$$



**FIGURE 5.5**

**Actual Indicator diagram:** Actual indicator diagram is shown in Figure 5.5.

Actual Indicator Diagram for Steam Engine

In actual indicator diagram (Figure 5.5), points 1, 2, 3, 4, and 5 show actual admission pressure, point of cut-off, point of release, point of closing the exhaust port and starting of compression, and point of opening of admission port respectively.

The area of actual indicator diagram is less than the theoretical indicator diagram.

$$\begin{aligned}
 \text{Diagram Factor} &= \frac{\text{Area of Actual Indicator diagram}}{\text{Area of Theoretical or hypothetical Indicator diagram}} \\
 &= \frac{\text{Mean effective pressure of Actual Indicator diagram}}{\text{Mean effective pressure of Theoretical or hypothetical Indicator diagram}}
 \end{aligned}$$

Indicated power of single acting reciprocating steam engine

$$= \frac{p_m \times L \times A \times N}{60000} \text{ kW}$$

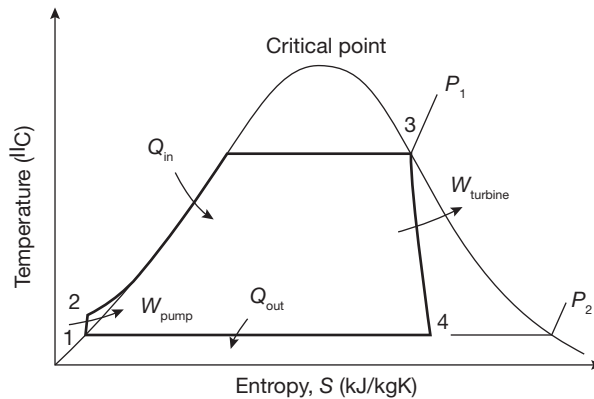
Indicated power of double acting reciprocating steam engine

$$= \frac{2p_m \times L \times A \times N}{60000} \text{ kW}$$

where  $p_m$  is a mean effective pressure,  $L$  is a length of stroke,  $A$  is a piston c/s area, and  $N$  is rpm.

### 5.2.2 Rankine Cycle

The Rankine cycle is most commonly used in thermal power plants: steam engine and steam turbines. The Rankine cycle is sometimes referred to as a practical Carnot cycle because, when an efficient turbine is used, the TS diagram begins to resemble the Carnot cycle. The main difference is that heat addition and rejection are at constant pressure in the Rankine cycle and isothermal in the theoretical Carnot cycle. A pump is used to pressurize the water received from the condenser. To pump the working fluid through the cycle as a liquid

**FIGURE 5.6**

Rankine Cycle

requires a very small fraction of the energy needed to transport it as compared to compressing the working fluid as a gas in a compressor (as in the Carnot cycle). Carnot efficiency of about 63% compared with an actual efficiency of 42% for a modern coal-fired power station.

The working fluid in a Rankine cycle follows a closed loop and is reused continuously. Work is required to drive the pump, the working fluid is in its liquid phase at this point. By condensing the fluid, the work required by the pump consumes only 1% to 3% of the turbine power and contributes to a much higher efficiency for a real cycle.

#### *Four Processes in the Rankine Cycle*

There are four important processes in the Rankine cycle. These states are identified by numbers as shown in Figure 5.6.

**Process 1–2 (Pumping Process):** The working fluid is pumped from low pressure to high pressure, as the fluid is a liquid at this stage the pump requires some small amount of input energy.

**Process 2–3 (Heating Process):** The high-pressure liquid enters a boiler where it is heated at constant pressure by an external heat source to become a dry saturated/superheated steam. The input energy required can be easily calculated using mollier diagram or h-s chart or enthalpy-entropy chart also known as steam tables.

**Process 3–4 (Expansion Process):** The dry saturated or superheated steam expands in the turbine. This decreases the temperature and pressure of the steam, and some condensation may occur. The output in this process can be easily calculated using the Enthalpy-entropy chart or the steam tables.

**Process 4–1 (Condensation Process):** The wet vapor then enters a condenser where it is condensed at a constant temperature to become a saturated liquid.

### Work done in Rankine Cycle

The flow diagram of a steam power plant is shown in Figure 5.7

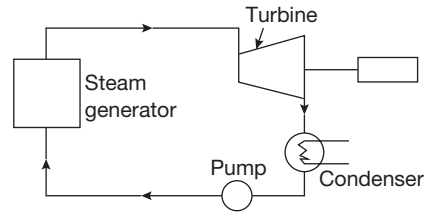
Suppose

$\dot{Q}_{in}$  heat supplied to water in turbine

$\dot{Q}_{out}$  Heat liberated in condenser

$\dot{W}_{pump}$  Work done on pump

$\dot{W}_{turbine}$  Work done by turbine



**FIGURE 5.7**

Flow Diagram of Power Plant

The thermal efficiency of Rankine cycle can be given as:

$$\eta_{thermal} = \frac{\dot{W}_{turbine} - \dot{W}_{pump}}{\dot{Q}_{in}}$$

where

$$\dot{W}_{turbine} = h_3 - h_4; \quad \dot{W}_{pump} = h_2 - h_1;$$

$$\dot{Q}_{in} = h_3 - h_2; \quad \dot{Q}_{out} = h_4 - h_1$$

## 5.3 ► STEAM TURBINES

Steam turbine is a prime mover, which converts the heat energy of steam into mechanical energy by rotating motion of the blade. Total energy conversion involves two types of steam expansion: expansion of steam in the nozzle and expansion of steam in turbine blades. The function of steam engines and steam turbine are similar, but the steam engine converts the heat energy of steam into mechanical energy by the reciprocating motion of the piston whereas in steam turbine the energy conversion takes place due to rotation of the turbine shaft. Steam energy is used for low power generation and efficiency is lesser than that of the steam turbine.

### 5.3.1 Classification of Steam Turbine

Broadly, steam turbine can be classified into two categories as follows:

1. Impulse Turbine
2. Impulse-Reaction Turbine

Pure reaction turbine cannot be used for practical purposes; therefore, the impulse-reaction turbine is referred as reaction turbine.

#### *Impulse Turbine (de-Laval Turbine)*

If torque produced on the shaft of the turbine is only due to change in momentum of steam and pressure of steam at the inlet and outlet of the turbine being same, it is known

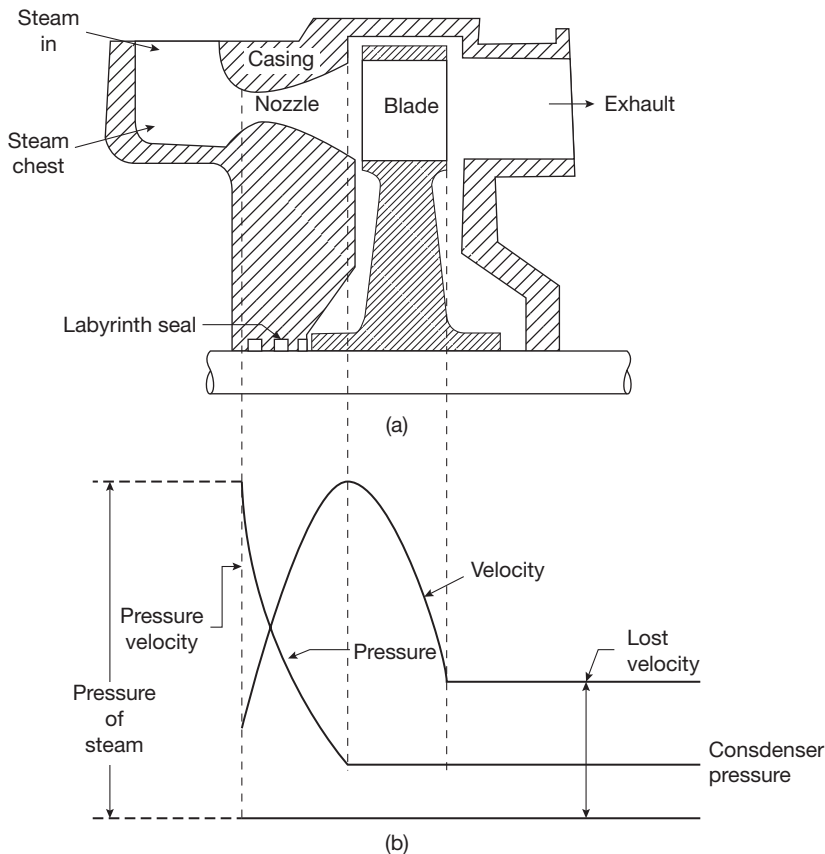
as impulse turbine. In this turbine, the expansion of high-pressure steam occurs only in the nozzle as shown in Figure 5.8 (a) and (b). During passage of steam through the blade, its direction changes which results in change in momentum equal to impulse on the blade.

$Fdt = d(mv)$ ; where  $Fdt$  is impulse and  $d(mv)$  is the change in momentum.

### Working of Impulse Turbine

In the impulse turbine, all the pressure drops occur in the nozzle and there is no pressure drop of steam passing through the blades. Let us consider steam enters the nozzle with the pressure of  $P_0$  and velocity of  $V_0$  after expansion of steam in nozzle pressure drops to  $P_1$  and velocity increases to  $V_1$ . High-velocity jets of steam impinge on the blades with velocity  $V_1$  gets deflected by an angle and comes out with a smaller velocity  $V_2$  producing an impulse on the blades. The pressure  $P_1$  remains constant passing through the blades.

Now, momentum at the inlet of the blade – momentum at the exit of the blade = Impulse on the blade absorbed in producing shaft work.



**FIGURE 5.8**

(a) Impulse Turbine (b) Pressure and Velocity Diagram

After expansion of steam in the nozzle, it strikes the blades with absolute velocity  $V_1$  which rotates the blade with mean peripheral velocity  $u$ , steam leaves the blade with relative velocity  $V_{r2}$  and absolute velocity  $V_2$  as shown in Figure 5.9.

$\alpha$  = nozzle angle with direction of rotation of wheel

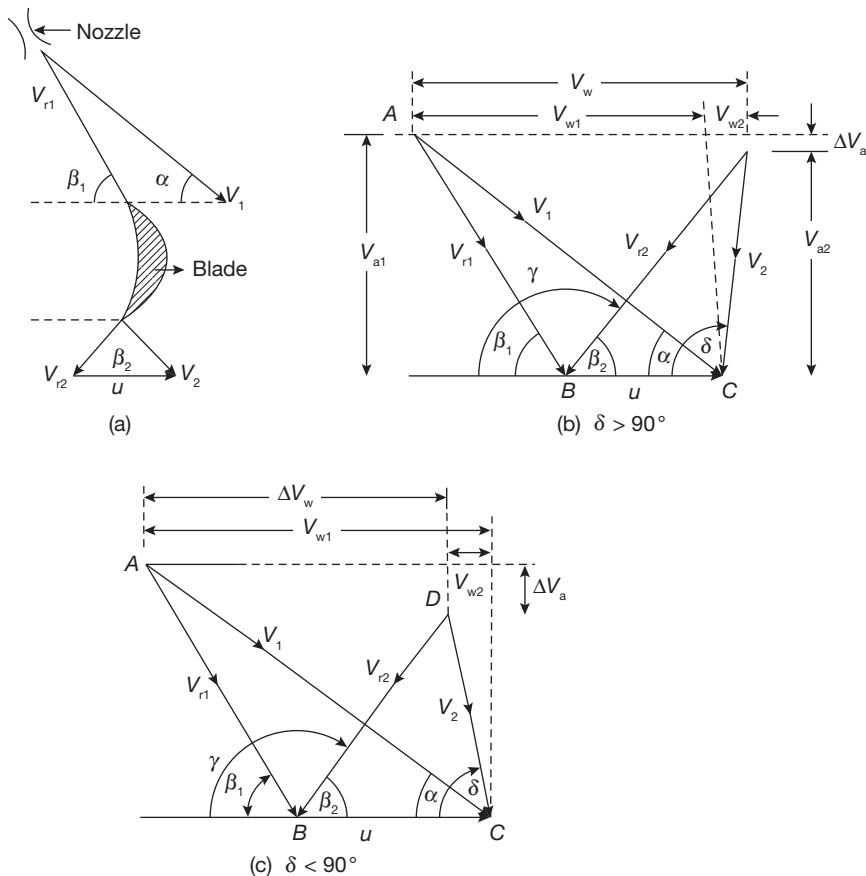
$\beta_1$  = inlet blade angle

$\beta_2$  = outlet blade angle

$u$  = peripheral velocity of wheel

Here,

- ▶  $\gamma$  = Exit blade angle
- ▶  $\delta$  = Angle made by absolute exit velocity of steam leaving the blades with the plane of rotation of wheel
- ▶  $V_\omega$  = Velocity of whirl



**FIGURE 5.9**

Velocity Diagram for Impulse Turbine

$$\Delta V_{\omega}, (\text{change in velocity of whirl}) = V_{\omega 1} - V_{\omega 2} = V_1 \cos \alpha - V_2 \cos \delta$$

$$\text{If } \delta > 90^\circ; \Delta V_{\omega} = V_{\omega 1} + V_{\omega 2}$$

$$\text{If } \delta < 90^\circ; \Delta V_{\omega} = V_{\omega 1} - V_{\omega 2}$$

In figure 5.9 (b), in  $\triangle ABC$

$$V_1 \cos \alpha - u = V_{r1} \cos \beta_1 \quad \text{and} \quad V_1 \sin \alpha = V_{r1} \sin \beta_1 = \frac{V_1 \sin \alpha}{V_1 \cos \alpha - u}$$

In  $\triangle CBD$

$$V_2 \cos(180 - \delta) + u = V_{r2} \cos(180 - \gamma)$$

$$u - V_2 \cos \delta = -V_{r2} \cos \gamma \quad \text{or} \quad V_2 \cos \delta = u + V_{r2} \cos \gamma$$

Similarly, in Figure 3.2(c)

$$u - V_2 \cos \delta = V_{r2} \cos(180 - \gamma) = -V_{r2} \cos \gamma$$

$$V_2 \cos \delta = u + V_{r2} \cos \gamma$$

### Blade Friction Factor

It is a ratio of the relative velocity of steam at the exit to the relative velocity at the inlet of the blade. It is denoted by  $K_b$

$$K_b = V_{r2} / V_{r1}$$

Energy loss due to friction in blade

$$\Delta E = \frac{V_{r1}^2 - V_{r2}^2}{2}$$

In terms of  $K_b$ ,  $\Delta V_{\omega} = (V_1 \cos \alpha - u)(1 + K_b)$ ; If blades are symmetrical, i.e.,  $\beta_1 = \beta_2$

### Tangential Thrust

$$F_t = \dot{m} \Delta V_{\omega}$$

### Axial Thrust

$$F_a = \dot{m} \Delta V_a; \quad \text{where } \Delta V_a = V_1 \sin \alpha - v_2 \sin \delta$$

### Blade Work or Diagram Work

$$W_D = F_t \times u = \dot{m} \Delta V_{\omega} \times u$$

$$\text{Input energy to the blade} = \frac{1}{2} \dot{m} \frac{V_1^2}{2}$$

### Blade or Diagram Efficiency

$$\eta_D = \frac{\text{Rate of work done on blade}}{\text{Rate of energy input to the blade}} = \frac{\dot{m}\Delta V_\omega \times u}{\frac{1}{2}\dot{m}\frac{V_1^2}{2}} = \frac{2\Delta V_\omega \times u}{V_1^2}$$

### Maximum Blade Efficiency and Optimum Velocity Ratio

Substituting  $\Delta V_\omega$  in equation of blade efficiency as

$$\Delta V_\omega = (V_1 \cos \alpha - u)(1 + K_b)$$

$$\eta_D = \frac{2\Delta V_\omega \times u}{V_1^2} = \frac{2(V_1 \cos \alpha - u)(1 + K_b) \times u}{V_1^2} = \frac{2u^2 \left( \frac{V_1 \cos \alpha}{u} - 1 \right) (1 + K_b)}{V_1^2}$$

Velocity ratio is the ratio of mean velocity to the jet velocity

$$\rho = \frac{u}{V_1}$$

as

$$\eta_D = 2\rho^2 \left( \frac{\cos \alpha}{\rho} - 1 \right) (1 + K_b) = 2(\rho \cos \alpha - \rho^2)(1 + K_b)$$

$$\frac{d\eta_D}{d\rho} = 0 = 2(\cos \alpha - 2\rho)(1 + K_b) \Rightarrow \rho_{opt} = \frac{\cos \alpha}{2} \quad \text{and} \quad \eta_{D_{max}} = \frac{1 + K_b}{2} \cos^2 \alpha$$

Putting the value of  $\rho$  as  $\frac{\cos \alpha}{2}$  and if loss of energy due to friction is zero, i.e.,  $K_b = 1$

$$\eta_{D_{max}} = \cos^2 \alpha$$

Thus, the lower is the nozzle angle, the higher is the blade efficiency. But, too low nozzle angle causes energy loss at the blade inlet. Therefore, the nozzle angle is to be maintained within a certain range which varies from  $16^\circ$  to  $22^\circ$ .

### EXAMPLE 5.1

Steam enters is an impulse turbine at 1000 m/s and at a nozzle angle of  $18^\circ$ . The mean peripheral velocity of the blades is 600 m/s and blades are symmetrical. If the steam is to enter the blades without shock, what will be the blade angles?

- (i) If the friction effect is negligible on the blades, calculate the tangential thrust on the blades and diagram power for a unit mass flow rate of steam.
- (ii) If blade friction ( $K_b$ ) is 0.8, estimate the axial thrust, diagram power, and diagram efficiency.



**SOLUTION**

Velocity triangle is shown in Figure 5.10

$$V_1 = 1000 \text{ m/s}, \alpha = 18^\circ, u = 600 \text{ m/s}.$$

Blades are symmetrical, i.e.,  $\beta_1 = \beta_2$ ;  $\dot{m} = 1 \text{ kg/s}$ .

$$V_{r1} \sin \beta_1 = V_1 \sin \alpha \quad (5.1)$$

$$V_{r1} \cos \beta_1 = V_1 \cos \alpha - u \quad (5.2)$$

or,

$$\tan \beta_1 = \frac{V_1 \sin \alpha}{V_1 \cos \alpha - u};$$

$$\text{or, } \beta_1 = \tan^{-1} \left( \frac{V_1 \sin \alpha}{V_1 \cos \alpha - u} \right)$$

$$= \tan^{-1} \left( \frac{1000 \text{ m/sec} \sin 18^\circ}{1000 \text{ m/sec} \cos 18^\circ - 600 \text{ m/sec}} \right) = 41.35^\circ$$

$$\beta_1 = \beta_2 = 41.35^\circ$$

(i) From Equation (5.1),

$$V_{r1} \sin 42.35^\circ = 309.01 \text{ m/sec} \quad \text{or,} \quad V_{r1} = 467.74 \text{ m/sec} = V_{r2}$$

$$\begin{aligned} \Delta V_\omega &= V_{r1} \cos \beta_1 + V_{r2} \cos \beta_2 = 2V_{r1} \cos \beta_1 \\ &= 2 \times 467.74 \text{ m/sec} \times 0.7506 = 702.25 \text{ m/sec} \end{aligned}$$

$$\Delta V_a = V_{r1} \sin \beta_1 - V_{r2} \sin \beta_2 = 0$$

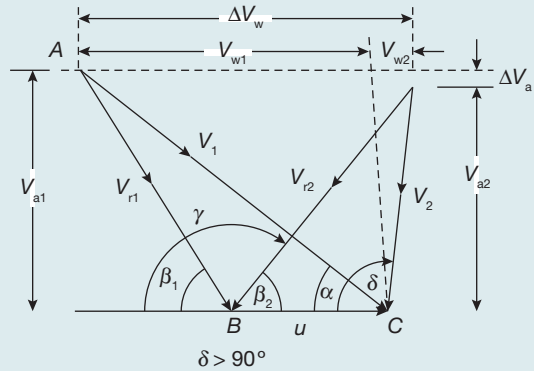
$$\text{Tangential thrust, } F_t = \dot{m} \times \Delta V_\omega = 1 \text{ kg/sec} \times 702.25 \text{ m/sec} = \mathbf{702.25 \text{ N}}$$

$$\text{Axial thrust, } F_a = \dot{m} \times \Delta V_a = 0$$

$$\text{Diagram Power, } W_D = F_t \times u = 702.25 \text{ N} \times 600 \text{ m/sec} = \mathbf{421.353 \text{ kW}}$$

$$\text{Kinetic energy of steam at the outlet of nozzle} = \frac{1}{2} \dot{m} V_1^2 = 500 \text{ kW}$$

$$\begin{aligned} \text{Diagram efficiency, } \eta_D &= \frac{\text{Diagram power}}{\text{Kinetic energy of steam at nozzle outlet}} \\ &= \frac{421.353 \text{ kW}}{500 \text{ kW}} = 0.8427 = 84.27\% \end{aligned}$$



**FIGURE 5.10**

Velocity Triangle

(ii)  $K_b = 0.8$

$$V_{r2} = 0.8V_{r1} = 0.8 \times 467.74 \text{ m/sec} = 374.192 \text{ m/sec}; \beta_1 = \beta_2 = 41.35^\circ$$

$$\Delta V_\omega = V_{r1} \cos \beta_1 + V_{r2} \cos \beta_2 = 632.028 \text{ m/sec}$$

$$\Delta V_a = V_{r1} \sin \beta_1 - V_{r2} \sin \beta_2 = 61.803 \text{ m/sec}$$

Tangential thrust,  $F_t = \dot{m} \times \Delta V_\omega = 1 \text{ kg/sec} \times 632.028 \text{ m/sec} = 632.028 \text{ N}$

Axial thrust,  $F_a = \dot{m} \times \Delta V_a = 1 \text{ kg/sec} \times 61.803 \text{ m/sec} = \mathbf{61.803 \text{ N}}$

Diagram Power,  $W_D = F_t \times u = 632.028 \text{ N} \times 600 \text{ m/sec} = \mathbf{379.216 \text{ kW}}$

Kinetic energy of steam at the outlet of nozzle =  $\frac{1}{2} \dot{m} V_1^2 = 500 \text{ kW}$

$$\text{Diagram efficiency, } \eta_b = \frac{\text{Diagram power}}{\text{Kinetic energy of steam at nozzle outlet}}$$

$$= \frac{379.21 \text{ kW}}{500 \text{ kW}} = 0.7584 = \mathbf{75.84\%}$$

### 5.3.2 Compounding of Impulse Turbine

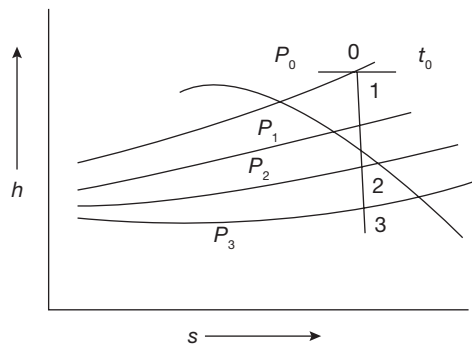
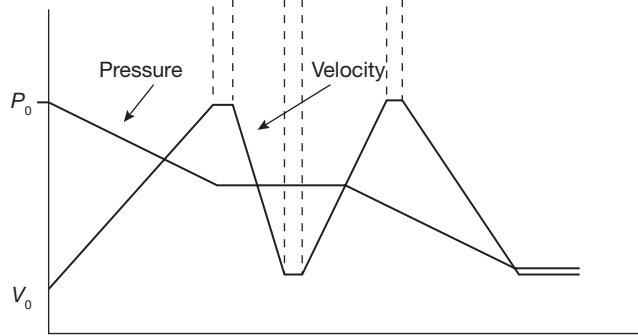
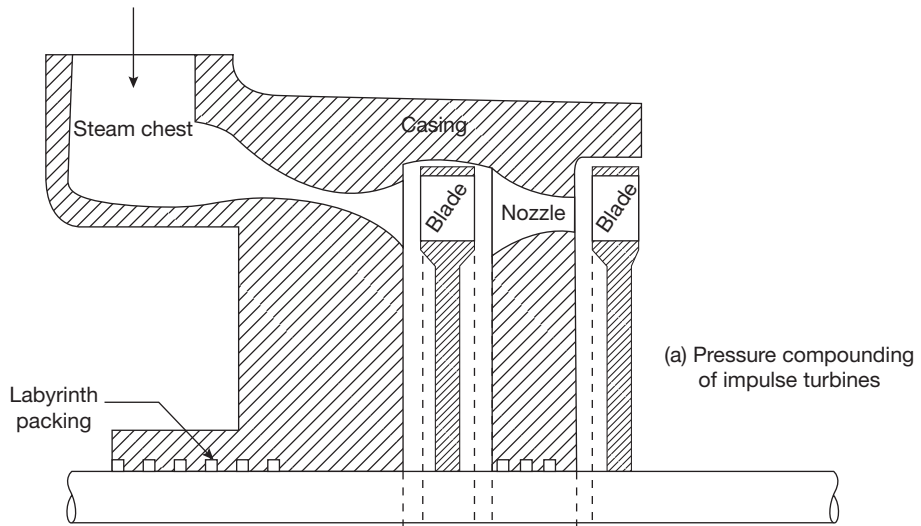
Single row of the nozzle with a single row of the blade is called one stage of the turbine. If steam at very high pressure is allowed to expand in a single stage of the turbine, the blade velocity will be too high. Such a high rotational speed cannot be used properly and also there will be velocity loss at the exit of the blade due to high exit velocity of steam. Therefore, to overcome these difficulties, the turbine is compounded or staged. In compounded turbines, steam is made to expand in a number of stages instead of single stage and turbine speed is reduced, which secures the same enthalpy drop of steam. There are three types of compounding of impulse turbine:

1. Pressure compounding or Reteau staging
2. Velocity compounding or Curtis staging
3. Pressure-velocity compounding.

#### *Pressure Compounding or Reteau Staging*

Pressure compounding is splitting of whole pressure drops of steam from the steam chest pressure to condenser pressure into a series of small pressure drops across several stages of impulse turbine. The whole pressure drops occur in the series of nozzles and there is no pressure drop in fixed blades as shown in Figure 5.11. The kinetic energy of steam increases in nozzles at the expense of the pressure drops and it is absorbed by the blades in producing a torque on the shaft.

The pressure compounding of the turbine is shown in Figure 5.11 (a) and pressure-velocity diagram in Figure 5.11 (b). The enthalpy drop in one stage is equal to the total enthalpy drop divided by the number of stages as shown in Figure 5.11 (c).



**FIGURE 5.11**

Pressure Compounding of Impulse Turbine

### Velocity Compounding or Curtis Stages

In this compounding, whole pressure drop takes place in the nozzle (only one row) and remains constant in fixed and moving blades. The velocity of the steam remains constant in fixed blades and decreases in moving blades.

Figure 5.12 (a) shows a two row Curtis or velocity staging having two rows of moving blades and one row of fixed blades in between them. In three-rows of Curtis stage, the two-row stage is followed by the second row of guide blade and third row of moving blades. Steam of high kinetic energy passing through nozzle impinges on the first row of moving blades and gets deflected by the first row of fixed blades of guide blades. The steam, after a deflection from the first row of fixed blades, impinges on the second row of moving blades and again gets deflected by second row of guide blades. Finally, steam impinges on the third row of moving blades and thus, does work on turbine shaft.

The velocity diagrams for first stage and second stage of moving blades are shown in Figure 5.12 (c) and (d). The blade friction factor  $K_b$  may be assumed the same for both moving and fixed blades.

$$\text{Hence, } \frac{V_{r2}}{V_{r1}} = \frac{V_3}{V_2} = \frac{V_{r4}}{V_{r3}} = K_b$$

$$\alpha_1 = \text{exit angle of guide blades}$$

$$\beta_1, \beta_2 = \text{Inlet and exit angles of first row of moving blades}$$

$$\beta_3, \beta_4 = \text{Inlet and exit angles of second row of moving blades}$$

$$\Delta V_{\omega 1}, \Delta V_{\omega 2} = \text{Change in the velocity component of the whirl in the first and second rows of moving blades}$$

$$\Delta V_{a1}, \Delta V_{a2} = \text{Change in the axial components of velocity in the first and second rows of moving blades}$$

$$\text{Tangential thrust, } F_t = \dot{m} \sum \Delta V_{\omega} = \dot{m} \sum (\Delta V_{\omega 1} + \Delta V_{\omega 2})$$

$$\text{Axial thrust, } F_a = \dot{m} \sum \Delta V_a = \dot{m} \sum (\Delta V_{a1} + \Delta V_{a2})$$

$$\text{Blade work or diagram work, } W_D = F_t \times u$$

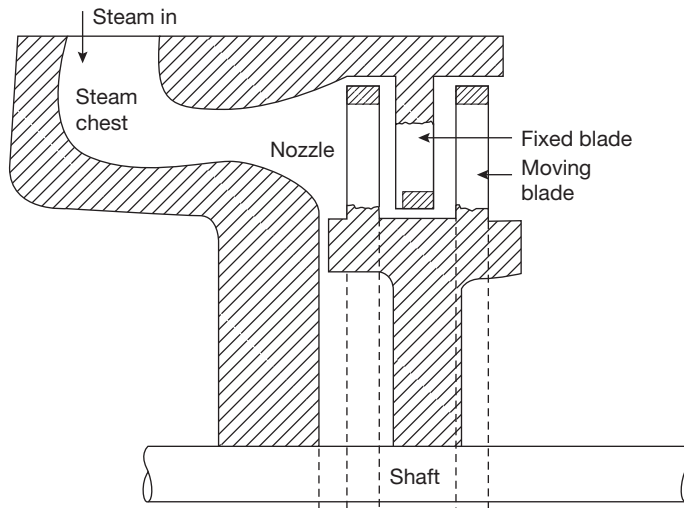
$$\text{Diagram efficiency, } \eta_D = \frac{2 \sum \Delta V_{\omega} \times u}{V_1^2}$$

- ▶ In two-row curtis stage,  $3/4^{\text{th}}$  of the total work is done by steam jets on the first row of moving blades and one-fourth of the total work is done on the second row of moving blades.
- ▶ In 3-rows curtis stage, it can be shown that

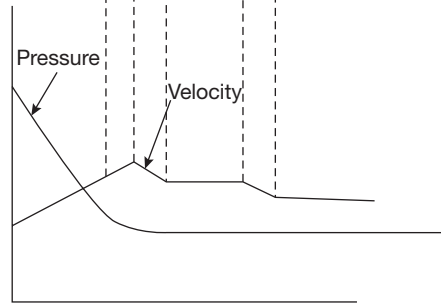
$$W_{D1} : W_{D2} : W_{D3} = 5 : 3 : 1$$

$$\eta_{D_{\max}} = \cos^2 \alpha$$

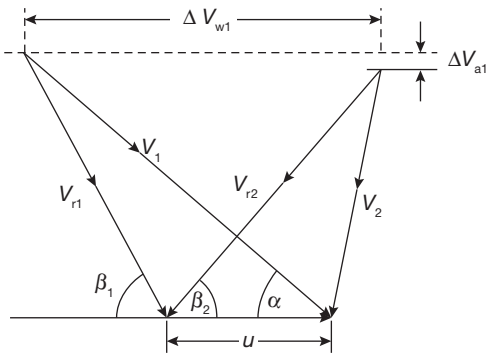
$$\text{Optimum velocity ratio} = \frac{u}{V_1} = \frac{\cos \alpha}{2n}; \text{ where } n \text{ is number of stages}$$



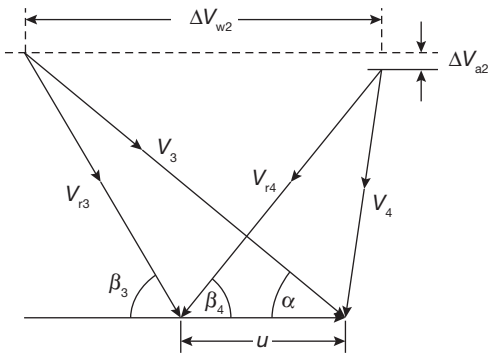
(a) Velocity compounding of impulse turbine



(b) Variation in pressure and velocity



(c) First stage



(d) Second stage

**FIGURE 5.12**

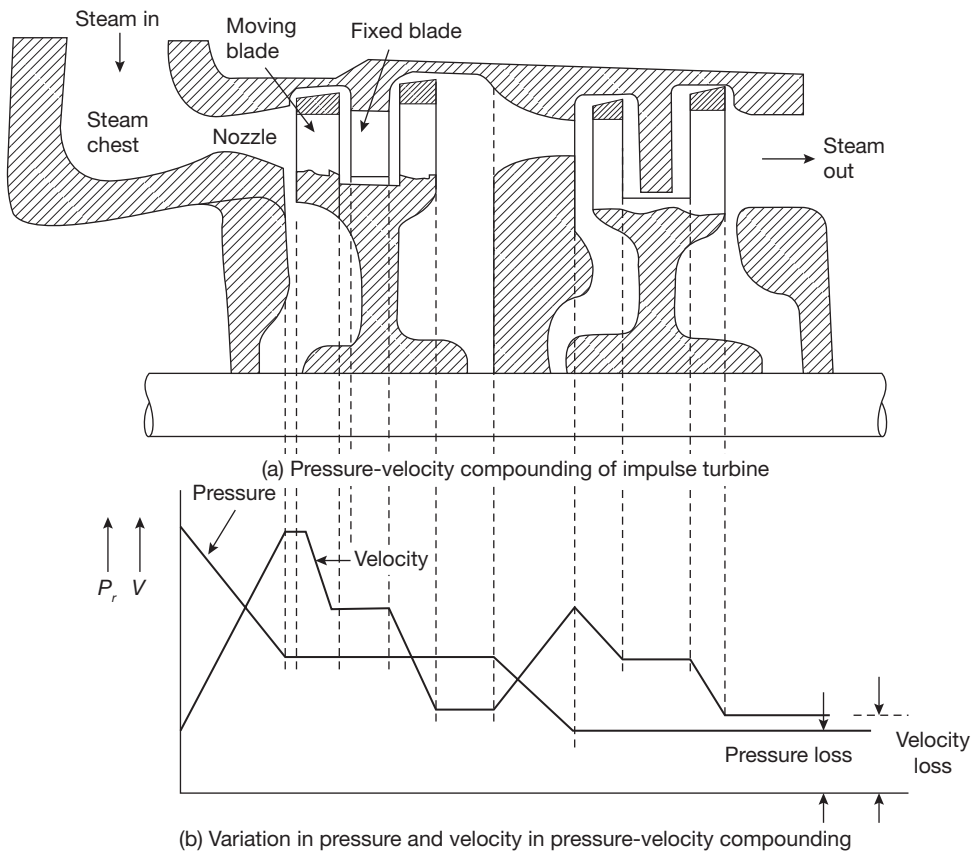
Velocity Compounding of Impulse Turbine

### Pressure-Velocity Compounding

It is a combination of pressure compounding and velocity compounding as shown in Figure 5.13 (a). There are two-rotors and only two rows of moving blades are attached on each rotor because two-row wheels are more efficient than three-row wheels. The steam on passing through each row of moving blades reduces its velocity, but the pressure remains constant during passing through these blades. Thus, it acts as a velocity compounded. The whole pressure drops in two nozzles as shown in Figure 5.13, thus, it acts as a pressure compounded.

### 5.3.3 Impulses-reaction Turbine (Reaction Turbine)

If steam expands both in the nozzle as well as in blades of a turbine, i.e., pressure at the inlet of the turbine is more than that of the outlet, it is known as an impulse-reaction turbine.



**FIGURE 5.13**

Pressure-Velocity Compounding of Impulse Turbine

In this case, expansion of steam in nozzle creates impulse on blades and the reaction due to the minor expansion of steam during passing through moving blades. The small drop in pressure of steam in the moving blades gives back pressure to the moving blades in the direction opposite to the velocity. In this turbine there are stages of fixed blades and moving blades; fixed blades act as nozzles that create an impact on the moving blades by reducing the pressure and increasing the velocity.

Since the moving blade channels are also of nozzle shape. Due to the expansion of steam, while flowing through the blades, there is an increase in kinetic energy that produces a reaction in the opposite direction (by Newton's third law of motion). The blades rotate due to both the impulse effect and the reaction force of steam jets. Such turbines are called impulse-reaction turbine or simply a reaction turbine.

The degree of reaction (R) of these turbines is defined as:

$$R = \frac{\Delta h_{mb}}{\Delta h_{fb} + \Delta h_{mb}} = \frac{\text{Enthalpy drops in moving blade}}{\text{Enthalpy drops in the stage}}$$

where, mb = moving blades

fb = fixed blades

**Note:**

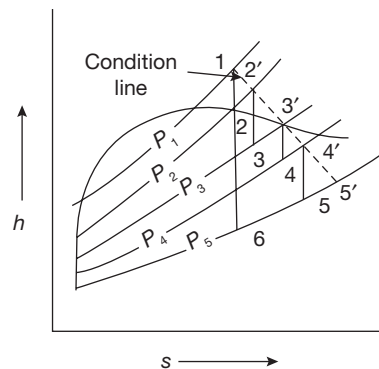
- ▶ If enthalpy drops in moving blade are zero, the degree of reaction will be zero. This is a case of the pure impulse turbine.
- ▶ If enthalpy drops in the fixed blade are zero, the degree of reaction will be one. This is a case of the pure reaction turbine.
- ▶ If enthalpy drops in the moving blades are equal to the enthalpy drop in the fixed blades, the degree of reaction will be 1/2 (half). This is a case of the Parson's reaction turbine.

**Reheat Factor**

It is the ratio of cumulative heat drops and isentropic heat drops in multistage turbine.

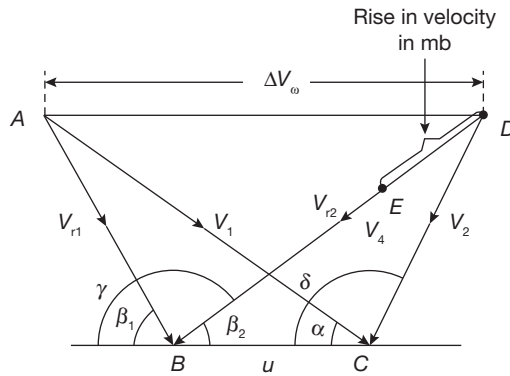
$$\text{Reheat factor} = \frac{h_c}{h_1} = \frac{h_{12} + h_{2'3} + h_{3'4} + h_{4'5}}{h_{16}}$$

The line which joins the actual points at the end of expansion in each stage is known as condition line (Figure 5.14).



**FIGURE 5.14**

Enthalpy Drops in Multistage Turbine


**FIGURE 5.15**

Velocity Diagram for 50% Reaction Turbine

### Velocity Diagram for Reaction Turbine

The velocity diagram for 50% reaction turbine is shown in Figure 5.15.

Since,

$$\triangle ABC \cong \triangle BCD$$

Therefore,  $V_{r1} = V_2$  and  $\beta_1 = 180^\circ - \delta$

Also,  $\beta_1 \neq \beta_2$ , the blades are unsymmetrical and  $\Delta V_a = 0$ . There is no axial thrust in 50% reaction turbine. However, there will be considerable tangential thrust produced due to the pressure difference across the blades in each rotor disc since there is a pressure drop of steam across the moving blades.

$$\begin{aligned} \Delta V_\omega &= V_1 \cos \alpha - V_2 \cos \delta = V_{r1} \cos \beta_1 - V_{r2} \cos \beta_2 \\ &= V_1 \cos \alpha - u + V_1 \cos \alpha = 2V_1 \cos \alpha - u \end{aligned}$$

The diagram work per kg of steam,

$$W_D = \Delta V_\omega u = (2V_1 \cos \alpha - u)u$$

$$\text{Energy input to blades/kg of steam} = \frac{V_1^2}{2} + \frac{V_{r2}^2 - V_{r1}^2}{2} = V_1^2 - \frac{V_{r1}^2}{2}$$

Now, 
$$V_{r1}^2 = V_1^2 + u^2 - 2V_1 \times u \times \cos \alpha$$

$$\begin{aligned} \text{Therefore, energy input to the blades} &= V_1^2 - \frac{V_1^2 + u^2 - 2V_1 \times u \times \cos \alpha}{2} \\ &= \frac{V_1^2 - u^2 + 2V_1 \times u \times \cos \alpha}{2} \end{aligned}$$



Diagram efficiency of blades

$$\eta_D = \frac{2(2V_1 \cos \alpha - u)}{V_1^2 - u^2 + 2V_1 \times u \times \cos \alpha} = \frac{2u^2 \left( \frac{2V_1 \cos \alpha}{u} - 1 \right)}{V_1^2 \left[ 1 - \left( u^2 / V_1^2 \right) + 2(u / V_1) \cos \alpha \right]}$$

Putting  $u/V_1 = \rho$  as the velocity ratio

$$\eta_D = \frac{2\rho^2 \left( \frac{2 \cos \alpha}{\rho} - 1 \right)}{1 - \rho^2 + 2\rho \cos \alpha} = \frac{2(2\rho \cos \alpha - \rho^2)}{1 - \rho^2 + 2\rho \cos \alpha}$$

There is an optimum value of  $\rho$  at which  $\eta_D$  becomes maximum. Differentiating  $\eta_D$  with respect to  $\rho$  and equating to zero. We get,

$$\rho_{opt} = \cos \alpha$$

$$\eta_{D_{max}} = \frac{2 \cos^2 \alpha}{1 + \cos^2 \alpha}$$

$$W_D = (2u - u)u = u^2$$

### EXAMPLE 5.2

A reaction turbine has the degree of reaction 50% (i.e., Parson's reaction turbine) and running at 600 rpm develops 10 MW using 10 kg/kWh of steam flow rate. The exit angle of the blades is  $18^\circ$  and the velocity of steam relative to the blade at the exit is 1.5 times the mean peripheral speed. At a particular stage in the expansion, the pressure is 1.2 bar and the steam quality is 90%. Calculate for the stage:

- (i) Blade height assuming the ratio of  $D_m/h_b$  as 12
- (ii) Diagram power

### SOLUTION

Velocity triangle is shown in Figure 5.16

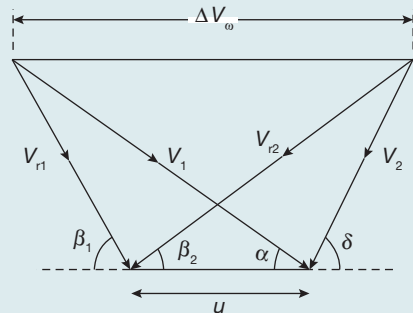
In a Parson's reaction turbine,

$$V_1 = V_{r2}, \quad V_2 = V_{r1},$$

$$B_1 = \delta \text{ and } \beta_2 = \alpha = 18^\circ$$

$$N = 600 \text{ rpm}, P = 10 \text{ MW}, \dot{m} = 10 \text{ kg / kWh}$$

$$= \frac{10 \text{ kg} \times 10 \times 10^3 \text{ kWh}}{3600 \text{ sec}} = 27.77 \text{ kg / sec.}$$



**FIGURE 5.16**  
Velocity Triangle

$$V_1 = V_{r2} = 1.5 \times u = 1.5 \times \frac{\pi D_m N}{60} = 1.5 \times \frac{\pi 12 h_b \times 600 \text{ rpm}}{60 \text{ sec}} = 180 \pi h_b$$

Volume of steam at 1.2 bar from steam table

$$V_1 = V_f + x V_{fg} = 0.001046 \text{ m}^3 / \text{kg} + 0.9 \times 1.454 \text{ m}^3 / \text{kg} = 1.382 \text{ m}^3 / \text{kg}$$

Volume flow rate of steam,  $\dot{m} \times V_1 = \pi D_m h_b V_1 \sin \alpha$

$$27.77 \text{ kg} / \text{sec} \times 1.382 \text{ m}^3 / \text{kg} = \pi (12 h_b) h_b (180 \pi h_b) \sin 18^\circ$$

$$h_b = 179.96 \text{ mm} \approx \mathbf{180 \text{ mm}}$$

$$u = 120 \pi h_b = 67.845 \text{ m} / \text{sec}$$

$$V_1 = 1.5u = 101.76 \text{ m} / \text{sec}$$

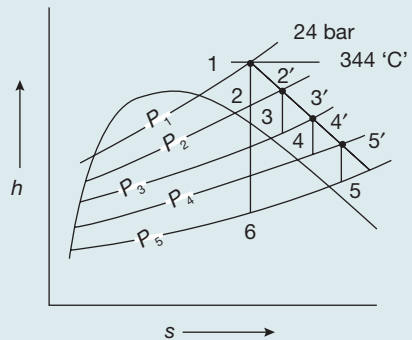
$$\Delta V_\omega = 2V_1 \cos \alpha - u = 125.72 \text{ m} / \text{sec}$$

$$\text{Diagram power, } P_D = \dot{m} \times \Delta V_\omega \times u = \mathbf{236.88 \text{ kW}}$$

### EXAMPLE 5.3

In a 4-stage turbine steam is supplied at 240 N/cm<sup>2</sup> and 344°C. The exhaust pressure is 0.686 N/cm<sup>2</sup> and the overall turbine efficiency is 0.72. Assuming that work is shared equally between stages and the condition line is a straight line. Find:

- (i) stage pressure
- (ii) efficiency of each stage
- (iii) reheat factor



**FIGURE 5.17**

*h-s* Diagram

### SOLUTION

*h-s* diagram for four stage turbine is shown in Figure 5.17

$$P_1 = 240 \text{ N} / \text{cm}^2 = \mathbf{24 \text{ bar}}; \quad t_1 = 344^\circ \text{C}; \quad \eta_T = 0.72; \quad P_5 = \mathbf{0.068 \text{ bar}}$$

From *h-s* Diagram,

$$h_1 = 3135 \text{ kJ} / \text{kg}; \quad P_6 = \mathbf{0.068 \text{ bar}}$$

Since work shared is equally divided between each stage,

$$h_1 - h_2 = \frac{h_1 - h_6}{4} = \frac{3135 \text{ kJ} / \text{kg} - 2140 \text{ kJ} / \text{kg}}{4} = 248.75 \text{ kJ} / \text{kg}$$

From Mollier diagram,

$$P_2 = 6.5 \text{ bar}, P_3 = 1.75 \text{ bar}, P_4 = 0.4 \text{ bar}, P_5 = 0.06 \text{ bar}$$

$$h_1 - h_6 = 3135 \text{ kJ/kg} - 2140 \text{ kJ/kg} = 995 \text{ kJ/kg}$$

$$h_1 - h'_5 = 0.72 \times 995 \text{ kJ/kg} = 716.4 \text{ kJ/kg}$$

$$\Rightarrow h'_5 = h_1 - 716.4 \text{ kJ/kg} = 3135 \text{ kJ/kg} - 716.4 \text{ kJ/kg} = 2418.6 \text{ kJ/kg}$$

$$h'_2 = 2975 \text{ kJ/kg}, h'_3 = 2800 \text{ kJ/kg}, h'_4 = 2620 \text{ kJ/kg}$$

$$h_2 = 2885 \text{ kJ/kg}, h_3 = 2725 \text{ kJ/kg}, h_4 = 2540 \text{ kJ/kg}, h_5 = 2340 \text{ kJ/kg}.$$

$$\text{Efficiency of first stage, } \eta_1 = \frac{h_1 - h'_2}{h_1 - h_2} = \frac{3135 \text{ kJ/kg} - 2975 \text{ kJ/kg}}{3135 \text{ kJ/kg} - 2885 \text{ kJ/kg}} = 0.64 = \mathbf{64\%}$$

$$\text{Efficiency of second stage, } \eta_2 = \frac{h'_2 - h'_3}{h_2 - h_3} = \frac{2975 \text{ kJ/kg} - 2800 \text{ kJ/kg}}{2975 \text{ kJ/kg} - 2725 \text{ kJ/kg}} = 0.70 = \mathbf{70\%}$$

$$\text{Efficiency of third stage, } \eta_3 = \frac{h'_3 - h'_4}{h_3 - h_4} = \frac{2800 \text{ kJ/kg} - 2620 \text{ kJ/kg}}{2800 \text{ kJ/kg} - 2540 \text{ kJ/kg}} = 0.692 = \mathbf{69.2\%}$$

$$\text{Efficiency of fourth stage, } \eta_4 = \frac{h'_4 - h'_5}{h_4 - h_5} = \frac{2620 \text{ kJ/kg} - 2418.6 \text{ kJ/kg}}{2620 \text{ kJ/kg} - 2340 \text{ kJ/kg}} = 0.719 = \mathbf{71.9\%}$$

(iii) Reheat factor = Cumulative heat drop/Isentropic heat drop

$$\begin{aligned} &= \frac{(h_1 - h_2) + (h'_2 - h_3) + (h'_3 - h_4) + (h'_3 - h_5)}{h_1 - h_6} \\ &= \frac{\left\{ (3135 \text{ kJ/kg} - 2885 \text{ kJ/kg}) + (2975 \text{ kJ/kg} - 2725 \text{ kJ/kg}) + \right. \\ &\quad \left. (2800 \text{ kJ/kg} - 2540 \text{ kJ/kg}) + (2620 \text{ kJ/kg} - 2340 \text{ kJ/kg}) \right\}}{3135 \text{ kJ/kg} - 2140 \text{ kJ/kg}} \\ &= \mathbf{1.045} \end{aligned}$$

### EXAMPLE 5.4

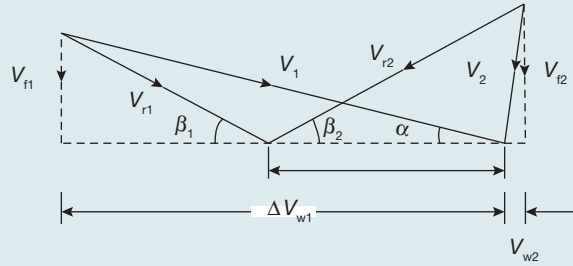
The enthalpy drop in the nozzle of an impulse turbine is 45 kJ/kg. The nozzle is inclined at  $14^\circ$  to the wheel tangent. The average diameter of the wheel is 0.3 m. Wheel runs at 10,000 rpm. Determine the blade inlet angle for sockless entry. If the blade exit angle is equal to the blade inlet angle, determine the work done/kg and also the axial thrust for the flow of 1 kg/s.

## SOLUTION

Velocity triangle is shown in Figure 5.18

$$V_1 = 44.72\sqrt{\Delta h} = 44.72 \times \sqrt{45 \text{ kJ/kg}} = 299.99 \text{ m}; \quad \left\{ \text{As } V = \sqrt{2g\Delta h} \right\}$$

$$\alpha = 14^\circ, D = 0.3 \text{ m}, N = 10000 \text{ rpm}, \dot{m} = 1 \text{ kg/sec.}$$



**FIGURE 5.18**

Velocity Triangle for the Example 5.4

$$u = \frac{\pi DN}{60} = 157.07 \text{ m/sec.}$$

$$V_{r1} \sin \beta_1 = V_1 \sin \alpha \quad (5.3)$$

$$V_{r1} \cos \beta_1 = V_1 \cos \alpha - u \quad (5.4)$$

From Equation (5.3) and (5.4),

$$\begin{aligned} \tan \beta_1 &= \frac{V_1 \sin \alpha}{V_1 \cos \alpha - u}; \quad \text{or,} \quad \beta_1 = \tan^{-1} \left( \frac{V_1 \sin \alpha}{V_1 \cos \alpha - u} \right) \\ &= \tan^{-1} \left( \frac{299.99 \text{ m/sec} \sin 14^\circ}{299.99 \text{ m/sec} \cos 14^\circ - 157.07 \text{ m/sec}} \right) = 28.439^\circ \end{aligned}$$

$$\beta_1 = \beta_2 = 28.439^\circ$$

Blade is frictionless, therefore  $V_{r1} = V_{r2}$

$$V_{r1} \sin \beta_1 = V_{r2} \sin \beta_2 = V_{f1} = V_{f2}$$

$$\text{Axial thrust} = \dot{m}(V_{f1} - V_{f2}) = 0$$

$$V_{\omega 1} = V_1 \cos \alpha = 299.99 \text{ m/sec} \times \cos 14^\circ = 291.07 \text{ m/sec}$$

$$V_{\omega 2} = V_{r2} \cos \beta_2 - u = 152.39 \text{ m/sec} \times \cos 28.439^\circ - 157.07 \text{ m/sec} = -23.051 \text{ m/sec}$$

(Thus, the direction of  $V_{\omega 2}$  will be reverse due to  $-ve$  sign)

$$\text{Work done per kg of steam} = \dot{m}(V_{\omega 1} + V_{\omega 2}) \times u$$

$$= 1 \text{ kg/sec} \times (291.07 \text{ m/sec} - 23.051 \text{ m/sec}) \times 157.07 \text{ m/sec}$$

$$= 42.097 \text{ kW/kg}$$

### 5.3.4 Differences Between Impulse and Reaction Turbines

There are some basic differences between impulse and reaction turbines as mentioned in Table 5.1.

**Table 5.1: Differences between Impulse and Reaction Turbines**

Impulse Turbines	Reaction Turbines
1. Pressure drops occur only in nozzles.	1. Pressure drops occur in moving blades as well as fixed blades.
2. It has a constant blade channel area.	2. It has varying blade channel area.
3. It has profile type blades.	3. It has aerofoil blade cross-section.
4. It can be used for small power development.	4. A considerable power developed is possible.
5. It has lower efficiency due to high losses.	5. It has higher efficiency than that of impulse turbines.

### 5.3.5 Losses in Steam Turbines

There may be two types of losses-internal loss and external loss. Internal loss includes all the losses the flow of steam inside the turbine, such as losses in regulating valves, nozzle friction loss, blade friction losses, disc friction losses, partial admission losses, leakage losses, residual velocity losses, and carry over losses, whereas external loss includes pipe loss, pump loss, radiation loss, etc.

### 5.3.6 Governing of Steam Turbines

Governing of steam turbines is to control the speed of turbines irrespective of load. There are following methods of governing:

- ▶ Throttle governing
- ▶ Nozzle control governing
- ▶ By-pass governing

In throttle governing system, the pressure of steam entering the turbine is reduced at part loads. It is used in only small turbines due to available heat loss in the irreversible throttling process. In nozzle governing system, a number of nozzles (4 to 12) are used with individual poppet valve and according to the load requirement steam is supplied to these nozzles through the valves. All nozzles may be in operation at full load and some nozzle may be idle at part load. In the bypass governing system, some part of the steam passes through the first stage and rest of steam passed through the second stage of the turbine. This is used in high-pressure turbines where the use of nozzle governing is not possible.

## 5.4 ► GAS TURBINES

The gas turbine is a rotating type prime mover which converts the heat energy of gas/air (at high pressure and temperature) into mechanical work. The principle of operation is based on Newton's Second Law of Motion. The motive power is obtained from the change in momentum of high-velocity jet impinge on curved blades of the turbine.

A simple as turbine consists of: (i) compressor, (ii) combustion chamber, and (iii) turbine. The gas turbine obtains its power by utilization of the energy of burnt gas and air at high-temperature and pressure expanding through the several rings of fixed and moving blades. To get a high pressure in order to 4 to 8 atm of the working fluid (gas) which essential for expansion, a compressor is required. The quantity of working fluid required is very high, therefore, a centrifugal or axial compressor is employed in gas turbines. The compressor is driven by a turbine and coupled with turbine shaft.

If after compression, the working fluid is to be expanded in a turbine and there is no loss in either component, the power developed by the turbine will be equal to the power required by compressor, i.e., work done will be equal to zero. But, the power developed by the turbine can be increased by increasing the volume of the working fluid at constant pressure or increasing the pressure at constant volume. Either of these can be done by heat addition so that the temperature of working fluid can be increased after compression. To get a high-temperature of the working fluid, a combustion chamber is used where combustion of fuel with air takes place.

Since, the compressor is coupled with turbine shaft, the compressor absorbs some part of the power produced by the turbine and the net work done by the turbine will be equal to the difference between work done by Turbine and work absorbed by the compressor. Gas turbines have been constructed to work on the fuels-oil, coal, gas, natural gas, producer gas, blast furnace gas, and pulverized coal.

### 5.4.1 Classification of Gas Turbine

Gas turbines can be classified on the basis of thermodynamic cycles used and the path of working fluid. On the basis of the thermodynamic cycle, there are two types of gas turbines: (i) Constant pressure cycle, i.e., Joule or Brayton cycle-heat addition and rejection are done at constant pressure, and (ii) Atkinson cycle-heat addition at constant volume and rejection at constant pressure. On the basis of the path of the working fluid, gas turbine can be classified as: (i) Open cycle gas turbine-Working fluid enters from the atmosphere and exhausts to the atmosphere. It works similar to I.C. Engine, and (ii) Closed cycle gas turbine- working fluid is confined within the plant and recirculated. The working is very similar to external combustion engines.

### 5.4.2 Applications of Gas Turbines

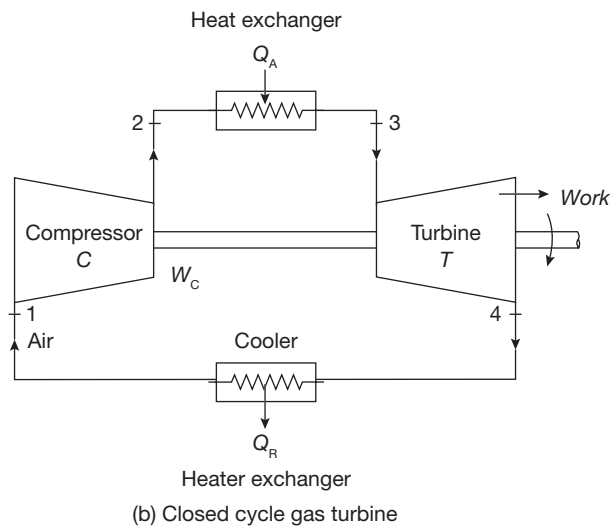
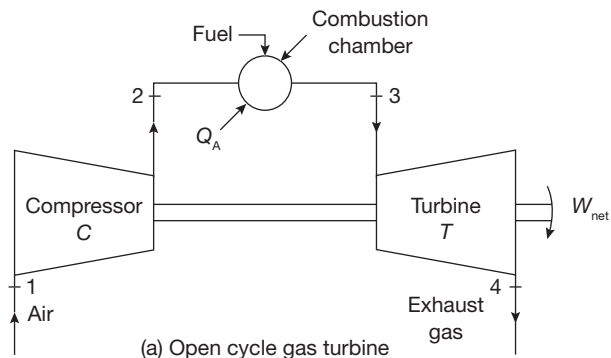
Gas turbines are used for the following purposes:

- Central power stations

- ▶ Stand-by power plants
- ▶ Locomotive power plants
- ▶ Jet engine
- ▶ Automotives
- ▶ Pumping station
- ▶ Main power source for laboratories
- ▶ vMarine, etc.

### Joule or Brayton Cycle

The air standard Brayton cycle or Joule cycle is a most ideal thermodynamic cycle for a simple gas turbine plant. Its working is shown in Figure 5.19. Atmospheric air is compressed from



**FIGURE 5.19**

Flow Diagram of Turbines

pressure  $P_1$  to a high-pressure  $P_2$  in the compressor and delivered to the combustion chamber where fuel is injected and burnt. The combustion process occurs nearly at constant pressure. During the combustion process, heat is added to the working fluid and its temperature rises from  $T_2$  to  $T_3$ . The product of combustion is expanded in the turbine from pressure  $P_3$  to atmospheric pressure and discharged into the atmosphere. The turbine and compressor are mechanically coupled to each other; hence the net work is the difference between turbine work and compressor work.

The actual gas turbine cycle is an open cycle; therefore fresh air must be continuously introduced into the compressor. In closed cycle gas cycle turbine, heat is added by an indirect method, called heat exchanger so that, there is no mixing of fuel and air. Similarly, the heat is rejected in another heat exchanger called cooler.

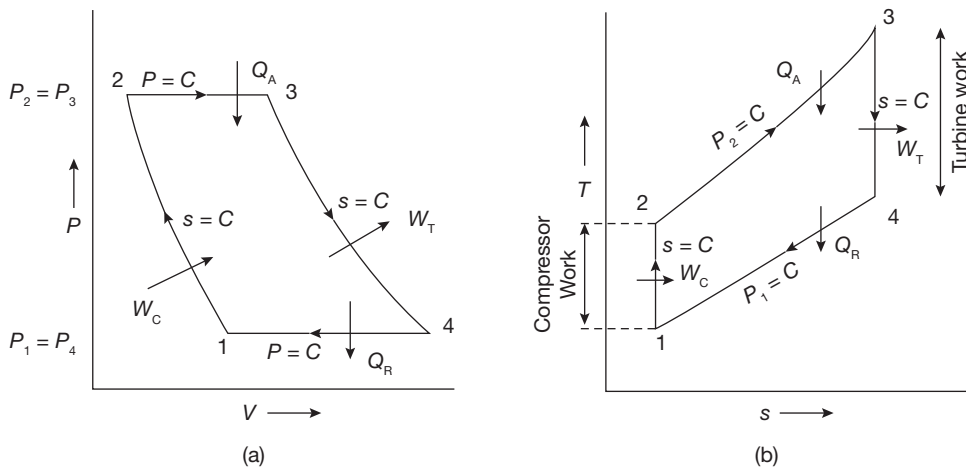
In the ideal diagram of Joule cycle, the cycle is assumed to be closed one and heat addition and rejection are only the heat transfer processes at constant pressure. The Joule cycle is shown on  $P$ - $V$  and  $T$ - $S$  diagram in Figure 5.20.

**1-2** Isentropic compression in the compressor thus raising pressure and temperature from  $P_1, T_1$  to  $P_2, T_2$ .

**2-3** Addition of heat at constant pressure raising the temperature from  $T_2$  to  $T_3$ .

**3-4** Isentropic expansion of air from high-pressure and high-temperature to low-pressure and low-temperature and thus doing work.

**4-1** Rejection of heat at constant pressure to restore the original state of the air.



**FIGURE 5.20**

$P$ - $V$  and  $T$ - $S$  Diagrams for Joule Cycle



The various processes are:

Heat addition to Combustion Chamber (CC)

$$Q_A = Q_{2-3} = h_3 - h_2 = C_p (T_3 - T_2)$$

Heat rejection from cooler

$$Q_R = Q_{4-1} = h_4 - h_1 = C_p (T_4 - T_1)$$

$$\text{Net work} = Q_A - Q_R = C_p [(T_3 - T_2) - (T_4 - T_1)]$$

The net work can also be found as:

$$\begin{aligned} W_{net} &= \text{Work done by turbine} - \text{Work done by compressor} \\ &= W_T - W_C = (h_3 - h_4) - (h_2 - h_1) = C_p [(T_3 - T_4) - (T_2 - T_1)] \\ &= C_p [(T_3 - T_2) - (T_4 - T_1)] \end{aligned}$$

$$\eta_{\text{thermal}} = \frac{\text{Net work}}{\text{Heat added}} = \frac{C_p [(T_3 - T_2) - (T_4 - T_1)]}{C_p (T_3 - T_2)} = 1 - \frac{T_4 - T_1}{T_3 - T_2} \quad (5.5)$$

Now, consider the process, 1-2

$$T_2 = T_1 \left( \frac{P_2}{P_1} \right)^{\frac{\gamma-1}{\gamma}}$$

From isentropic expansion process, 3-4

$$\frac{T_3}{T_4} = \left( \frac{P_3}{P_4} \right)^{\frac{\gamma-1}{\gamma}}$$

But,  $P_2 = P_3$  and  $P_1 = P_4$

Therefore,  $\frac{T_2}{T_1} = \frac{T_3}{T_4} = \left( \frac{P_2}{P_1} \right)^{\frac{\gamma-1}{\gamma}}$

or  $\frac{T_1}{T_2} = \frac{T_4}{T_3} = \frac{T_4 - T_1}{T_3 - T_2}$

Putting the value of  $\frac{T_4 - T_1}{T_3 - T_2}$  in Equation (5.5), we get

$$\eta_{\text{thermal}} = 1 - \frac{T_1}{T_2} = 1 - \frac{T_4}{T_3}$$

$$r_p = \text{Pressure ratio} = \frac{P_2}{P_1}$$

Here,

$$\frac{T_2}{T_1} = \left( \frac{P_2}{P_1} \right)^{\frac{\gamma-1}{\gamma}} = (r_p)^{\frac{\gamma-1}{\gamma}}$$

or  $\frac{T_1}{T_2} = \frac{1}{(r_p)^{\frac{\gamma-1}{\gamma}}}$ ; where  $\gamma = \frac{C_p}{C_v} = 1.4$  for air

$$\eta_{\text{thermal}} = 1 - \frac{1}{(r_p)^{\frac{\gamma-1}{\gamma}}}$$

Hence, we can say that the thermal efficiency progressively increases with increasing the value of pressure ratio.

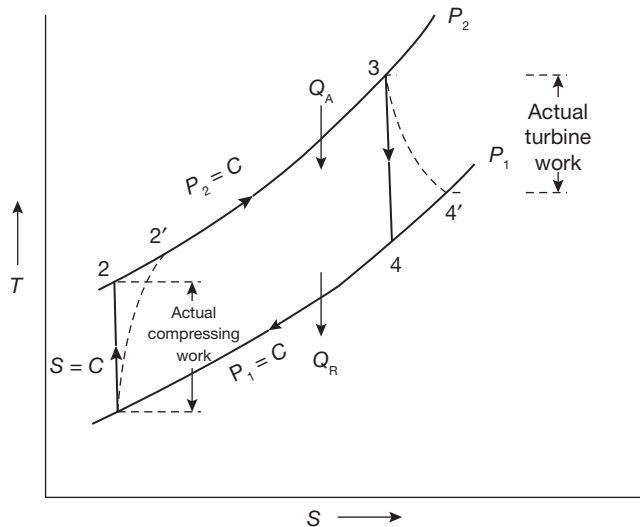
### Actual Brayton Cycle

The actual turbine cycle differs from the theoretical cycle in the following manner:

1. Due to frictional losses in the compressor and turbine, entropy increases in compression and expansion process. In the ideal case the compressor efficiency ( $\eta_c$ ) and turbine efficiency ( $\eta_T$ ) are 100%, but in practice, they are less than 100% efficient.
2. A small pressure loss occurs in the combustion chamber. This loss is so little that it can be neglected for the sake of simplicity.
3. The specific heat of combustion gas is slightly higher than that of air. This increase is so little that the specific heat of combustion gas may be taken as that of air for simplicity wherever necessary.

A T-S diagram for an actual Brayton cycle is shown in Figure 5.21.

- 1-2 Isentropic compression
- 1-2' Actual compression
- 3-4 Isentropic expansion
- 3-4' Actual expansion



**FIGURE 5.21**

Actual Brayton Cycle

The compressor efficiency,

$$\eta_c = \frac{\text{Isentropic compression work}}{\text{Actual compression work}} = \frac{C_p(T_2 - T_1)}{C_p(T_2' - T_1)} = \frac{T_2 - T_1}{T_2' - T_1}$$

$$\text{Turbine efficiency, } \eta_T = \frac{\text{Actual Turbine work}}{\text{Isentropic Turbine work}} = \frac{C_p(T_3 - T_4')}{C_p(T_3 - T_4)} = \frac{T_3 - T_4'}{T_3 - T_4}$$

$$\begin{aligned} \text{Actual thermal efficiency, } \eta_{\text{thermal}} &= \frac{\text{Net work}}{\text{Heat addition}} = \frac{(T_3 - T_4') - (T_2' - T_1)}{(T_3 - T_2')} \\ &= \frac{\eta_T(T_3 - T_4) - (T_2 - T_1) / \eta_c}{(T_3 - T_2')} \\ &= \frac{\eta_T \eta_c (T_3 - T_4) - (T_2 - T_1)}{\eta_c (T_3 - T_2')} = \frac{\eta_T \eta_c W_T - W_c}{Q_A \times \eta_c} \end{aligned}$$

Where  $W_T$  = Work done by turbine

$W_c$  = Work done compressor

$Q_A$  = Actual heat addition

### Optimum Pressure Ratio for Maximum Specific Output

In the T-S diagram (Figure 5.22),

$$\frac{T_3}{T_4} = \frac{T_2}{T_1} = \left( \frac{P_2}{P_1} \right)^{\frac{\gamma-1}{\gamma}} = \left( \frac{P_3}{P_1} \right)^{\frac{\gamma-1}{\gamma}} = (r_p)^{\frac{\gamma-1}{\gamma}} = \text{Constant, } c$$

$$\text{Let } \eta_c = \text{Compressor efficiency} = \frac{T_2 - T_1}{T_2' - T_1};$$

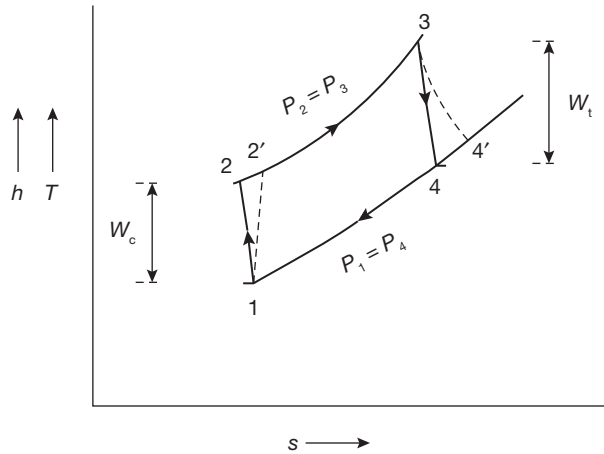
$$\eta_T = \text{Turbine efficiency} = \frac{T_3 - T_4'}{T_3 - T_4}$$

$$W_c = \frac{h_2 - h_1}{\eta_c} = \frac{C_p(T_2 - T_1)}{\eta_c} \quad \text{and} \quad W_T = (h_3 - h_4) \times \eta_T = C_p(T_3 - T_4) \times \eta_T$$

$$W_{\text{net}} = W_T - W_c = C_p \eta_T T_3 \left( 1 - \frac{T_4}{T_3} \right) - \frac{C_p T_1}{\eta_c} \left( \frac{T_2}{T_1} - 1 \right) = C_p \eta_T T_3 \left( 1 - \frac{1}{c} \right) - \frac{C_p T_1}{\eta_c} (c - 1)$$

For Maximum work done,  $W_{\text{net}}$  should be differentiated with respect to  $c$  and equating to zero.

$$\frac{dW_{\text{net}}}{dc} = 0 = C_p \eta_T T_3 \left( \frac{1}{c^2} \right) - \frac{C_p T_1}{\eta_c}$$


**FIGURE 5.22**

Actual Brayton Cycle

Therefore,

$$c = \sqrt{\eta_T \eta_c \frac{T_2}{T_1}} = (r_p)^{\frac{\gamma-1}{\gamma}} = \left( \eta_T \eta_c \frac{T_3}{T_1} \right)^{1/2}$$

Since

$$\frac{T_3}{T_4} = \frac{T_2}{T_1} = \left( \frac{P_2}{P_1} \right)^{\frac{\gamma-1}{\gamma}} = (r_p)^{\frac{\gamma-1}{\gamma}} = c$$

$$r_p = \left( \eta_T \eta_c \frac{T_3}{T_1} \right)^{\frac{\gamma}{2(\gamma-1)}}$$

If  $\eta_T = \eta_c = 100\%$ ;

$$r_p = \left( \frac{T_3}{T_1} \right)^{\frac{\gamma}{2(\gamma-1)}} = \left( \frac{T_{\max}}{T_{\min}} \right)^{\frac{\gamma}{2(\gamma-1)}}$$

### EXAMPLE 5.5

In a gas turbine plant, air is compressed from 1 bar and 15°C through a pressure ratio 6:1. It is then heated to 600°C in a combustion chamber and expanded back to atmospheric pressure of 1 bar in a turbine. Calculate the cycle efficiency and the work ratio. The isentropic efficiency of the turbine and compressor are 85% and 80%, respectively.

### SOLUTION

T-s diagram for the gas turbine is shown in Figure 5.23

$$T_1 = 237 + 15 = 288\text{K}$$

$$P_1 = 1\text{ bar}$$

$$T_3 = 600^\circ\text{C} + 273 = 873\text{K}$$

$$P_2 = 6\text{ bar, since } r_p = 6$$

$$\begin{aligned} T_2 &= T_1 \left( \frac{P_2}{P_1} \right)^{\frac{\gamma-1}{\gamma}} = T_1 (r_p)^{\frac{\gamma-1}{\gamma}} \\ &= 288(6)^{\frac{0.4}{1.4}} = 480.53\text{K} \end{aligned}$$

Efficiency of compressor

$$= 0.8 = \frac{T_2 - T_1}{T_2' - T_1} = \frac{480.53\text{K} - 288\text{K}}{T_2' - 288\text{K}}$$

$$\Rightarrow T_2' = \frac{480.53\text{K} - 288\text{K}}{0.8} + 288\text{K} = 528.66\text{K}$$

$$\text{Efficiency of turbine} = 0.85 = \frac{T_3 - T_4'}{T_3 - T_4} = \frac{873\text{K} - T_4'}{873\text{K} - T_4}$$

$$T_4 = T_3 \left( \frac{P_4}{P_3} \right)^{\frac{\gamma-1}{\gamma}} = T_3 \left( \frac{1}{r_p} \right)^{\frac{\gamma-1}{\gamma}} = 873\text{K} (1/6)^{\frac{0.4}{1.4}} = 523.22\text{K}$$

$$0.85 = \frac{873\text{K} - T_4'}{873\text{K} - 523.22\text{K}} \Rightarrow T_4' = 873\text{K} - 0.85(299.77\text{K}) = 618.188\text{K}$$

$$\text{Heat supplied} = C_p (T_3 - T_2') = 1.005\text{kJ/kgK} (873\text{K} - 528.66\text{K}) = 346.06\text{kJ/kg}$$

$$\text{Compressor work} = C_p (T_2' - T_1) = 1.005\text{kJ/kgK} (528.66\text{K} - 288\text{K}) = 241.863\text{kJ/kg}$$

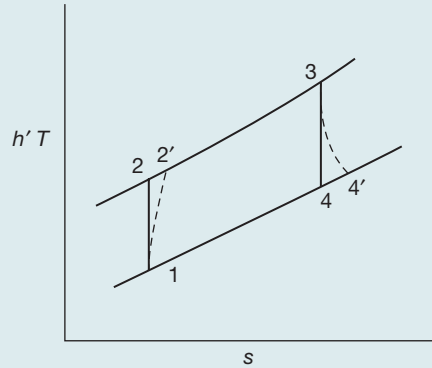
$$\text{Turbine work} = C_p (T_3 - T_4') = 1.005\text{kJ/kgK} (873\text{K} - 618.188\text{K}) = 256.086\text{kJ/kg}$$

$$\text{Net work} = \text{Turbine work} - \text{Compressor work}$$

$$= 256.086\text{kJ/kg} - 241.863\text{kJ/kg} = 14.223\text{kJ/kg}$$

$$\eta_{\text{thermal}} = \frac{\text{Net work}}{\text{Heat supplied}} = \frac{14.223\text{kJ/kg}}{346.06\text{kJ/kg}} = 0.0410 = 4.1\%$$

$$\text{Work ratio} = \frac{\text{Net work}}{\text{Turbine work}} = \frac{14.223\text{kJ/kg}}{256.086\text{kJ/kg}} = 0.0555$$



**FIGURE 5.23**

T-s Diagram

**EXAMPLE 5.6**

In Example 5.5, if the combustion efficiency is 0.98. Fall in pressure through combustion chamber is 0.1 bar. Determine: (i) the thermal efficiency, (ii) the work ratio, (iii) air rate in kg/kW, and (iv) the specific fuel consumption (v) the air-fuel ratio. For air  $C_p = 1.005 \text{ kJ/kgK}$ ;  $\gamma = 1.333$ . Calorific value = 42,700 kJ/kg,  $C_{pg} = 1.147 \text{ kJ/kg}$ .

**SOLUTION**

From solution of example 5.5  $T_1 = 288\text{K}$ ,  $T_2 = 480.53\text{K}$ ,  $T_2' = 528.6\text{K}$ ,  $T_3 = 873\text{K}$

$$P_3 = 6\text{bar} - 0.1\text{bar} = 5.9\text{bar}, \quad \frac{T_3}{T_4} = \left(\frac{P_3}{P_4}\right)^{\frac{\gamma-1}{\gamma}} = (5.9)^{\frac{0.333}{1.333}} = 1.5585$$

$$T_4 = \frac{873\text{K}}{1.5585} = 560.153\text{K}$$

$$\eta_T = 0.85 = \frac{T_3 - T_4'}{T_3 - T_4};$$

$$T_4' = T_3 - 0.85(T_3 - T_4) = 873\text{K} - 0.85(873\text{K} - 560.153\text{K}) = 607.08\text{K}$$

$$\begin{aligned} \text{Net work done per kg of air} &= C_{pg}(T_3 - T_4') - C_{pa}(T_2' - T_1) \\ &= 1.147 \text{ kJ/kgK}(873\text{K} - 607.08\text{K}) - 1.005 \text{ kJ/kgK}(528.6\text{K} - 288\text{K}) = 63.207 \text{ kJ/kg.} \end{aligned}$$

$$\text{(i) Thermal efficiency, } \eta_{\text{thermal}} = \frac{\text{Network}}{\text{Heat supplied}} = \frac{63.207 \text{ kJ/kg}}{346.06 \text{ kJ/kg}} = 0.1826 = \mathbf{18.26\%}$$

$$\text{(ii) Work ratio} = \frac{\text{Network}}{\text{Turbine work}} = \frac{63.207 \text{ kJ/kg}}{1.147 \text{ kJ/kgK}(873\text{K} - 607.08\text{K})} = \mathbf{0.207}$$

$$\text{(iii) Air rate} = \frac{3600}{\text{Network}} = \frac{3600}{63.207 \text{ kJ/kg}} = \mathbf{56.955 \text{ kg/kWh}}$$

$$\begin{aligned} \text{(iv) Specific fuel consumption} &= \frac{\text{Heat supplied per kg of air} \times \text{air rate}}{\text{Calorific value}} \\ &= \frac{346.06 \text{ kJ/kg} \times 56.955 \text{ kg}}{42700 \text{ kJ/kg} \times 0.98} \\ &= \mathbf{0.452 \text{ kg/kWh}} \end{aligned}$$

$$\text{(v) air-fuel ratio} = \frac{56.955 \text{ kg}}{0.452 \text{ kg}} = \mathbf{126}$$

## EXAMPLE 5.7

Air enters the compressor of gas turbine plant operating on the Brayton cycle at 1 bar and 27°C. The pressure ratio in the cycle is 6. Calculate the maximum temperature in the cycle and the cycle efficiency, heat rate. Assume  $W_T = 3 W_c$ , where  $W_T$  and  $W_c$  are the turbine and compressor work, respectively. Take  $\gamma = 1.4$ .

## SOLUTION

T-s diagram for the gas turbine is shown in Figure 5.24.

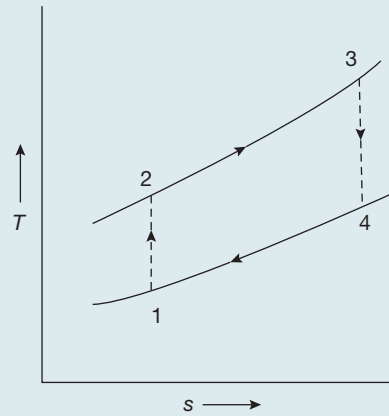


FIGURE 5.24

T-s Diagram

$$\text{Pressure ratio} = \frac{P_2}{P_1} = 6$$

$$T_2 = T_1 \left( \frac{P_2}{P_1} \right)^{\frac{\gamma-1}{\gamma}} = T_1 (r_p)^{\frac{\gamma-1}{\gamma}} = 300\text{K} (6)^{\frac{0.4}{1.4}} = 500.55\text{K}$$

$$\frac{T_3}{T_4} = \left( \frac{P_3}{P_4} \right)^{\frac{\gamma-1}{\gamma}} = (6)^{\frac{0.4}{1.4}} = 1.668 = \frac{T_2}{T_1}$$

Now, from question,  $W_T = 3W_c$

$$C_p (T_3 - T_4) = 3 \times C_p (T_2 - T_1)$$

$$\text{or, } T_3 (1 - T_4 / T_3) = 3 \times (T_2 - T_1) = 3 \times (500.55\text{K} - 300\text{K}) = 601.65\text{K}$$

$$\text{or, } T_3 = \frac{601.65\text{K}}{(1 - 1/1.668)} = \mathbf{1501.67\text{K}}$$

$$T_4 = \frac{T_3}{1.668} = \frac{1501.67\text{K}}{1.668} = 900\text{K}$$

$$\text{Cycle efficiency} = \frac{\text{Turbine work} - \text{Compressor work}}{\text{Heat added}}$$

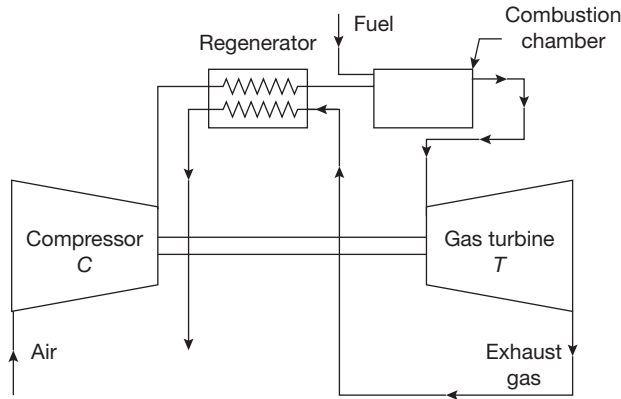
$$= \frac{(T_3 - T_4) - (T_2 - T_1)}{(T_3 - T_2)}$$

$$= \frac{(1501.67\text{K} - 900\text{K}) - (500.55\text{K} - 300\text{K})}{(1501.67\text{K} - 500.55\text{K})} = 0.399 = \mathbf{39.90\%}$$

$$\text{Heat rate} = \frac{3600}{\eta} = \frac{3600}{0.399} = \mathbf{9020.82 \text{ kJ/kWh}}$$

### 5.4.3 Gas Turbine Cycle with Regenerator

The regenerator is a heat exchanger, which is used to exchange the waste heat of gases exhausted from the turbine to air after compression but before combustion as shown in Figure 5.25. Due to this fuel economy, the efficiency of plant increases.

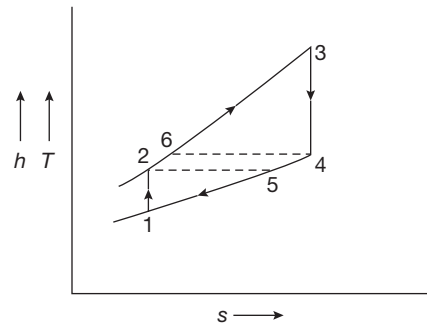


**FIGURE 5.25**

Gas Turbine with Regenerator

It is theoretically possible to raise the temperature of the compressed air from  $T_2$  to  $T_6 = T_4$  and reduce the temperature of the gas leaving the turbine from  $T_4$  to  $T_5 = T_2$  by arranging a counter flow heat exchanger. The  $T$ - $S$  diagram of the Brayton cycle for a gas turbine with regenerator is shown in Figure 5.26.

Addition of heat exchanger in a gas turbine cycle increases the value of both overall efficiency and specific output for a given pressure ratio, but the increase in output is very nominal because regenerator lowers the pressure ratio at which peak efficiency occurs.



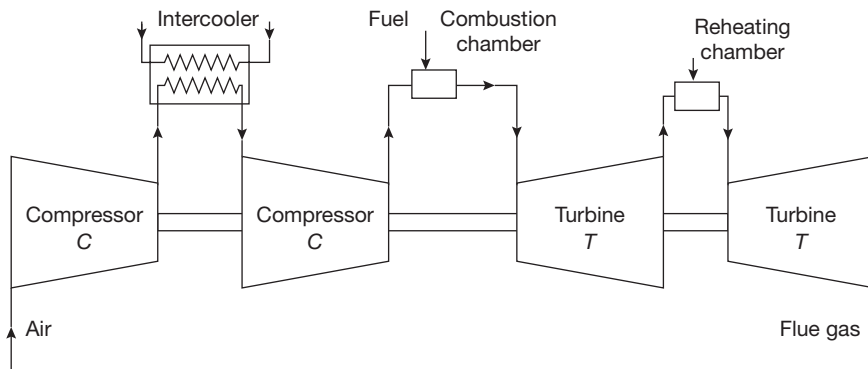
**FIGURE 5.26**

$T$ - $S$  Diagram of the Brayton Cycle using Regenerator

### 5.4.4 Gas Turbine Cycle with Reheating and Intercooling

Intercooling is added to reduce the compressor work. If the multistage compressor is used, the air is cooled to initial temperature between each stage. The reheater is used to increase the temperature to an initial inlet temperature between each expansion in turbines. Thus,





**FIGURE 5.27**

Flow Diagram of a Gas Turbine with Intercooling and Reheating

the intercooler and the reheater are used to increase the work output of turbines. The flow diagram using intercooling and reheating is shown in Figure 5.27.

## RECAP ZONE .....



### Points to Remember

- The **steam power system** is a system in which the heat energy of the steam is used to produce mechanical power.
- A **steam engine** is a reciprocating heat engine that performs mechanical work using steam as its working fluid.
- **Steam engines** are external combustion engines based on modified Rankine cycle, where the working fluid is separate from the combustion products.
- Steam turbine is a prime mover, which converts the heat energy of steam into mechanical energy by rotating motion of the blade.
- Total energy conversion involves two types of steam expansion: expansion of steam in the nozzle and expansion of steam in turbine blades.
- **Pure reaction turbine** cannot be used for practical purposes; therefore, the impulse-reaction turbine is referred as **reaction turbine**.
- If torque produced on the shaft of the turbine is only due to change in momentum of steam and pressure of steam at the inlet and outlet of the turbine being same, it is known as **impulse turbine**.
- Single row of the nozzle with the single row of the blade is called one stage of the turbine.
- In **compounded turbines**, the steam is made to expand in a number of stages instead of single stage and turbine speed is reduced which secures the same enthalpy drop of steam.
- **Pressure compounding** is the splitting of whole pressure drops of steam from steam chest pressure to condenser pressure into a series of small pressure drops across several stages of impulse turbine.
- The whole pressure drops occur in the series of nozzles and there is no pressure drop in fixed blades.

- **Pressure-velocity compounding** is a combination of pressure compounding and velocity compounding as the steam on passing through each row of moving blades reduces its velocity, but the pressure remains constant during passing through these blades but when steam passes through fixed blades, its pressure reduces and velocity remains constant.
- If steam expands both in the nozzle as well as in blades of the turbine, i.e., pressure at the inlet of the turbine is more than that of the outlet, it is known as an **impulse-reaction turbine**.
- The degree of reaction (R) of these turbines is defined as the ratio of enthalpy drop in moving blades and enthalpy drop in the stage.
- **Reheat factor** is the ratio of cumulative heat drops and isentropic heat drops in multistage turbine.
- The gas turbine is a rotating type prime mover which converts the heat energy of gas/air (at high pressure and temperature) into mechanical work.
- A simple gas turbine consists of (i) compressor, (ii) combustion chamber, and (iii) turbine.
- Intercooling is added to reduce the compressor work.
- If the multistage compressor is used, the air is cooled to initial temperature between each stage.
- The reheater is used to increase the temperature to an initial inlet temperature between each expansion in turbines.
- The intercooler and the reheater are used to increase the work output of turbines.

## Important Formulae

1. Tangential thrust  $F_t = \dot{m} \Delta V_\omega$

2. Axial thrust  $F_a = \dot{m} \Delta V_a$ ; where  $\Delta V_a = V_1 \sin \alpha - v_2 \sin \delta$

3. Blade work or Diagram work  $W_D = F_t \times u = \dot{m} \Delta V_\omega \times u$

$$\text{Input energy to the blade} = \frac{1}{2} \dot{m} \frac{V_1^2}{2}$$

4. Blade or Diagram efficiency  $\eta_D = \frac{\text{Rate of work done on blade}}{\text{Rate of energy input to the blade}} = \frac{\dot{m} \Delta V_\omega \times u}{\frac{1}{2} \dot{m} \frac{V_1^2}{2}} = \frac{2 \Delta V_\omega \times u}{V_1^2}$

5.  $\eta_{D_{\max}} = \frac{1 + K_b}{2} \cos^2 \alpha$

6. Degree of reaction  $R = \frac{\Delta h_{mb}}{\Delta h_{fb} + \Delta h_{mb}} = \frac{\text{Enthalpy drops in moving blade}}{\text{Enthalpy drops in the stage}}$

where, mb = moving blades

fb = fixed blades

7. Reheat factor = (Cumulative heat drop)/(Isentropic heat drop)

8. For Reaction Turbine  $\rho_{opt} = \cos \alpha$

$$\eta_{D_{\max}} = \frac{2 \cos^2 \alpha}{1 + \cos^2 \alpha}$$

$$W_D = (2u - u)u = u^2$$

9. Efficiency of Gas Turbine  $\eta_{\text{thermal}} = 1 - \frac{1}{(r_p)^{\frac{\gamma-1}{\gamma}}}$

10. Optimum Pressure Ration in Gas Turbine  $r_p = \left(\frac{T_3}{T_1}\right)^{\frac{\gamma}{2(\gamma-1)}} = \left(\frac{T_{\text{max}}}{T_{\text{min}}}\right)^{\frac{\gamma}{2(\gamma-1)}}$



## REVIEW ZONE

### Objective Questions

#### Steam Turbine

- In an impulse turbine, steam expands:
  - Fully in nozzle
  - Fully in blades
  - Partly in nozzle and partly in blades
  - None of the above
- In impulse turbines, pressure on the two sides of the moving blades:
  - Increases
  - Decreases
  - Remains same
  - None of the above
- In impulse turbine, when steam flows over the moving blades:
  - Velocity decreases
  - Velocity increases
  - Pressure decreases
  - None of the above
- In a reaction steam turbine, steam expands:
  - In nozzle only
  - In moving blades only
  - Partly in nozzle partly in blades
  - None of the above
- De-Lavel Turbine is a:
  - Simple impulse turbine
  - Simple reaction turbine
  - Pressure compounded turbine
  - Velocity compounded turbine
- Parson's Turbine is a:
  - Simple impulse turbine
  - Simple reaction turbine
  - Pressure compounded turbine
  - Velocity compounded turbine
- Curtis turbine is:
  - Simple impulse turbine
  - Simple reaction turbine
  - Pressure compounded turbine
  - Velocity compounded turbine
- Rateu turbine is:
  - Simple impulse turbine
  - Simple reaction turbine
  - Pressure compounded turbine
  - Velocity compounded turbine
- The turbine having identical fixed and moving blades is:
  - De-Lavel turbine
  - Parson's reaction turbine
  - Rateau turbine
  - Zoelly turbine
- In reaction turbine, stage is represented by:
  - Each row of blades
  - Number of casting
  - Number of steam exits
  - None of the above
- Blade efficiency is the ratio of:
  - Work done of blades and energy supplied to the blades
  - Work done on blade and energy supplied to each stage
  - Energy supplied per stage and work done on the blades
  - Energy supplied to blades and work done on blades.
- Maximum efficiency of Parson's reaction turbine is equal to:
 

(a) $\frac{\cos^2 \alpha}{1 + 2 \cos^2 \alpha}$	(b) $\frac{2 \cos^2 \alpha}{1 + \cos^2 \alpha}$
(c) $\frac{1 + 2 \cos^2 \alpha}{\cos^2 \alpha}$	(d) $\frac{1 + \cos^2 \alpha}{2 \cos^2 \alpha}$

13. For maximum efficiency of a Parson's reaction turbine, the speed ratio is equal to:
- (a)  $\frac{\cos \alpha}{2}$                       (b)  $\cos \alpha$   
 (c)  $\cos^2 \alpha$                       (d)  $\frac{\cos^2 \alpha}{2}$
14. For maximum blade efficiency of a single stage impulse turbine, the blade speed is equal to:
- (a)  $\frac{\cos \alpha}{2}$                       (b)  $\cos \alpha$   
 (c)  $\cos^2 \alpha$                       (d)  $\frac{\cos^2 \alpha}{2}$
15. The compounding of turbine:
- (a) Increases efficiency  
 (b) Decreases rotor speed  
 (c) Decreases exit loss  
 (d) All of the above

## Gas Turbine

16. A gas turbine works on:
- (a) Rankine cycle                      (b) Carnot cycle  
 (c) Joule cycle                      (d) Erriction cycle
17. When working fluid in a plant doesn't come in contact with the atmospheric air, and is used again, turbine is said to work on:
- (a) Open cycle                      (b) Closed cycle  
 (c) Semi-closed cycle                      (d) None of these
18. When the entire fluid is taken from the atmosphere and is return back to the atmosphere, the gas turbine is said to work on:
- (a) Open cycle  
 (b) Closed cycle  
 (c) Semi-closed cycle  
 (d) None of these
19. Efficiency of closed cycle gas turbine as compared to open cycle gas turbine is:
- (a) More                      (b) Less  
 (c) Same                      (d) None of the above
20. Regenerator in gas turbine:
- (a) Increases thermal efficiency  
 (b) Decreases heat loss in exhaust  
 (c) Allows use of higher compression ratio  
 (d) All of the above
21. Compressors used in as turbine are:
- (a) Reciprocating type  
 (b) Centrifugal type  
 (c) Axial flow type  
 (d) None of the above
22. Intercooling in gas turbine:
- (a) Increases thermal efficiency  
 (b) Decreases compression work  
 (c) Increases turbine work  
 (d) None of the above
23. Reheating in as turbine:
- (a) Increases thermal efficiency  
 (b) Decreases compression work  
 (c) Increases turbine work  
 (d) None of the above
24. The air-fuel ratio in gas turbine is:
- (a) 15:1                      (b) 30:1  
 (c) 45:1                      (d) 50:1
25. The pressure ratio in gas turbine is of the order of:
- (a) 2:1                      (b) 4:1  
 (c) 6:1                      (d) 8:1

## Fill in the Blanks

26. The ratio of useful heat drop to isentropic heat drop is called \_\_\_\_\_.
27. De-Lavel turbine is normally used for \_\_\_\_\_ pressure and \_\_\_\_\_ Speed.
28. The pressure-velocity compounded steam turbine allows a \_\_\_\_\_ pressure drop and hence \_\_\_\_\_ number of stages are required.
29. In impulse-reaction turbine, the pressure drops gradually and continuously over \_\_\_\_\_ blades.
30. The parson's reaction turbine has \_\_\_\_\_ and \_\_\_\_\_ blades.
31. In reaction turbine, the degree of reaction is zero. This implies \_\_\_\_\_ heat drops in moving blades.

## Answers

- |                                |                   |               |                 |                      |         |
|--------------------------------|-------------------|---------------|-----------------|----------------------|---------|
| 1. (a)                         | 2. (c)            | 3. (c)        | 4. (a)          | 5. (a)               | 6. (b)  |
| 7. (d)                         | 8. (c)            | 9. (b)        | 10. (a)         | 11. (a)              | 12. (b) |
| 13. (b)                        | 14. (a)           | 15. (d)       | 16. (c)         | 17. (b)              | 18. (a) |
| 19. (a)                        | 20. (d)           | 21. (c)       | 22. (b)         | 23. (c)              | 24. (d) |
| 25. (c)                        | 26. Reheat factor | 27. Low, high | 28. High, less, | 29. Fixed and moving |         |
| 30. Identical fixed and moving |                   | 31. Zero      |                 |                      |         |

## Theory Questions

1. With a neat sketch explain the construction and working of a single stage impulse steam turbine.
2. What is compounding of impulse turbine? With a neat sketch explain the working of velocity compounding.
3. With a neat sketch explain the working of pressure-velocity compounding of impulse steam turbine.
4. Differentiate impulse and reaction type steam turbines.
5. Write short notes on: (i) Degree of reaction, (ii) Reheat factor, (iii) Diagram efficiency, and (iv) condition line.
6. Explain the methods of governing of the steam turbine.
7. Explain the working of closed cycle gas turbine.
8. Explain the working principle of the open cycle gas turbine.
9. What is a gas turbine? What are the essential components of a gas turbine plant? How it differs from a steam turbine?
- \*10. What are the purposes of regeneration, inter-cooling and reheating in a gas turbine? Compare Rankine cycle with Carnot cycle.
- \*11. Derive the equation for thermal efficiency of Rankine cycle.
- \*12. Discuss the classification of turbines. Also, discuss compounding of impulse turbine.
- \*13. Explain the working principle of a gas turbine on closed cycle.
- \*14. List any four differences between closed cycle and open cycle gas turbines.
- \*15. What are the advantages of the steam turbine over reciprocating engines?
- \*16. Write the function of the following:
  - (a) Nozzle
  - (b) Moving blade
  - (c) Guide blades in steam turbine
- \*17. Why is gas turbine used in aviation?
- \*18. Derive an expression for the air standard efficiency of a Brayton cycle in terms of pressure ratio.
- \*19. State the working principle of a closed cycle gas turbine. Why is it named as constant pressure turbine?
- \*20. What is compounding of an impulse turbine? State the principle of working of an open-cycle gas turbine. What are the advantages of gas turbines over Steam turbines?

\* indicates that similar questions have appeared in various university examinations.

## Numerical Problems

1. In a single row impulse turbine, the blade speed is 200 m/sec, nozzle angle is  $18^\circ$ . If the steam enters with an absolute velocity of 300 m/sec. Find: (i) inlet and outlet angles of moving blade so that there is no axial thrust, (ii) power developed for a steam flow of 1 kg/sec, and (iii) kinetic energy of steam leaving the stage.
2. A reaction turbine has a degree of reaction 50% (i.e., Parson's reaction turbine) and running at 500 rpm develops 8 MW using 10 kg/kWh of steam flow rate. The exit angle of the blades is  $18^\circ$  and the velocity of steam relative to the blade at exit is 2 times the mean peripheral speed. At a particular stage in the expansion, the pressure is 1.2 bar and the steam quality is 90%.  
Calculate for the stage:
  - (i) Blade height assuming the ratio of  $Dm/hb$  as 12
  - (ii) Diagram power
3. In a 4-stage turbine, steam is supplied at 300 N/cm<sup>2</sup> and 3800C. The exhaust pressure is 0.05 N/cm<sup>2</sup> and the overall turbine efficiency is 0.7. Assuming that work is shared equally between stages and the condition line is a straight line. Find: (i) stage pressure, (ii) efficiency of each stage, and (iii) reheat factor.
4. The enthalpy drop in the nozzle of an impulse turbine is 50 kJ/kg. The nozzle is inclined at  $160^\circ$  to the wheel tangent. The average diameter of the wheel is 0.25 m. Wheel runs at 11,000 rpm. Determine the blade inlet angle for sockless entry. If the blade exit angle is equal to the blade inlet angle, determine the work done/kg and also the axial thrust for the flow of 1 kg/s.
5. In a gas turbine plant, air is compressed from 1 bar and  $30^\circ\text{C}$  through a pressure ratio 6:1. It is then heated to  $600^\circ\text{C}$  in a combustion chamber and expanded back to atmospheric pressure of 1 bar in a turbine. Calculate the cycle efficiency and the work ratio. The isentropic efficiency of the turbine and compressor are 85% and 80%, respectively.
6. Air enters the compressor of gas turbine plant operating on Brayton cycle at 1 bar and  $20^\circ\text{C}$ . The pressure ratio in the cycle is 4. Calculate the maximum temperature in the cycle and the cycle efficiency, heat rate. Assume  $W_T = 2W_C$ . Where  $W_T$  and  $W_C$  are the turbine and compressor work, respectively. Take  $\gamma=1.4$ .
7. In a gas turbine cycle, the condition of air at the entrance of compressor is 1 bar and  $27^\circ\text{C}$ . Pressure ratio is 6. Maximum temperature is  $700^\circ\text{C}$ . The exhaust pressure of turbine is 1 bar. Assume 100% efficiency of compressor and 95% efficiency of both turbines and combustion, fall in pressure through combustion chamber is 0.1 bar, calculate: (i) thermal efficiency, (ii) work ratio, (iii) heat rate, (iv) air-rate in kg/kW, (v) specific fuel consumption, and (vi) the air-fuel ratio.  
 $C_p = 1.005 \text{ kJ/kg}$   
 $C_{p,pg} = 1.147 \text{ kJ/kg}$   
 $C_v = 42,700 \text{ kJ/kg}$
- \*8. 1.5 kg of steam at a pressure of 10 bar and temperature of  $250^\circ\text{C}$  is expanded until the pressure becomes 2.8 bar. The dryness fraction of steam is then 0.9. Calculate the change in internal energy. [Hint: Find the value of internal energy of steam ( $u_1$ ) at 10 bar and  $250^\circ\text{C}$ , then find the internal energy ( $u_2$ ) at 2.8 bar as  $u_2 = u_f + 0.9(u_g - u_f)$  and then find  $\Delta u = 1.5kg(u_1 - u_2)$ ]

\* indicates that similar questions have appeared in various university examinations.

# Internal Combustion Engines

## Learning Objectives

*By the end of this chapter, the student will be able:*

- To demonstrate the construction and working of different parts of an internal combustion engine
- To understand the mechanism of fuel combustion in the internal combustion engines
- To demonstrate the Otto cycle, Diesel cycle, and Dual cycle
- To describe the various methods of emission control
- To demonstrate the latest development in fuel injection technologies in petrol and diesel engines and also, the concept of hybrid cars

## 6.1 ► INTRODUCTION

“The heat engine, in which the combustion takes place inside the cylinder or the product of combustion (flue gas) directly goes to the cylinder and the heat energy of the flue gas is converted into mechanical energy, is known as Internal Combustion Engine (I.C. Engine)”. The combustion may take place either inside or outside the cylinder, but heat energy of the combustion is directly utilized by the engine to produce mechanical power. However, in external combustion engines, the heat of the combustion is transferred to the intermediate medium like water or air and then the heat energy of that intermediate medium (steam produced from the water or the hot air) is converted into the mechanical energy. The steam engine/turbine and closed cycle gas turbine work on the principle of the external combustion engine as the heat of combustion is transferred to water and air respectively. The steam produced from water in case of steam engine/turbine and hot compressed air in case of closed cycle gas turbine produce mechanical power. While the automobile and open cycle gas turbine work on the principle of internal combustion engine as the flue gas produced

during the combustion process produces mechanical power without transferring the heat energy to any intermediate medium.

## 6.2 ► CLASSIFICATION OF I.C. ENGINES

There are several bases for classification of I.C. Engines, some of the important bases can be explained as:

- ▶ Number of strokes per cycle
- ▶ Nature of thermodynamic cycle
- ▶ Ignition systems
- ▶ Fuel used
- ▶ Arrangement of cylinders
- ▶ Cooling systems
- ▶ Fuel supply systems

**Number of Strokes Per Cycle:** I.C. Engines can be classified as four-stroke engines (4S) and two-stroke engines (2s). In four-stroke engines, the thermodynamic cycle is completed in four strokes of the piston or two revolutions of the crankshaft whereas, in two-stroke engines, the thermodynamic cycle is completed in two strokes of the piston or one revolution of the crankshaft.

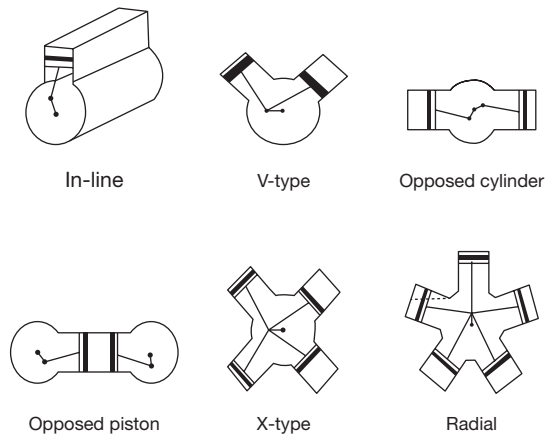
**Nature of Thermodynamic Cycle:** I.C. Engines can be classified as Otto cycle, Diesel cycle, and Dual cycle engine. In an Otto cycle engine, heat addition and heat rejection occur at constant volume; therefore, this is also known as constant volume engine, whereas, in the Diesel cycle engine, heat addition occurs at constant pressure and heat rejection occurs at constant volume. In Dual cycle, heat addition occurs partly at constant volume and partly at constant pressure, but heat rejection occurs fully at constant volume.

**Ignition Systems:** There are two modes of ignition of fuel inside the cylinder—spark ignition and self or compressed ignition. In spark ignition, sparking starts at the end of compression stroke from spark plug while in compressed ignition the temperature of the fuel increased to the self-ignition point by compressing the air alone and at the end of compression, fuel is injected into the cylinder.

**Fuel Used:** On the basis of fuel used, I.C. Engines can be classified as (a) gas engines like CNG, natural gas, etc. (b) Petrol engine, (c) Diesel Engine, and (d) Bi-fuel engine. In a bi-fuel engine, two types of fuel are used like gaseous fuel and liquid fuel.

**Arrangement of Cylinders:** According to the arrangement of cylinders (Figure 6.1), I.C. Engines can be classified as (a) In-line engines, (b) V-engines, (c) Opposed cylinder engines, (d) Opposed piston engines, (e) X-type engines, and (f) Radial engines.



**FIGURE 6.1**

Classification of I.C. Engines on the Basis of Cylinders Arrangement

In an in-line cylinder engine, all the cylinders are arranged linearly and transmit power through a single crankshaft. V-engines have two banks of cylinders arranged in the shape of English letter V and single crankcase and crankshaft is used to transmit the power. In an opposed cylinder engine, all the cylinders lie in the same plane, but the cylinders are arranged both sides of the crankshaft at  $180^\circ$ . It is inherently well balanced. When a single cylinder houses two pistons each of which drives a separate crankshaft, it is called an opposed piston engine. The moments of the pistons are synchronized by coupling two crankshafts. It is also inherently well balanced. X-type engines have four cylinders with the single crankcase and single crankshaft. The cylinders are arranged in the shape of English letter X. In a radial engine, the cylinders are arranged radial directions like the spokes of a wheel and are connected to a single crankshaft. These engines are used in conventional air-cooled aircraft engines.

**Cooling Systems:** there are two types of cooling systems in I.C. Engines—water cooling and air cooling. In water cooling, coolant and radiators are provided to cool the cylinder. In air cooling, fins are provided on the surface of the cylinder to radiate the heat into the atmosphere. Low power engines like motorbikes are equipped with air cooling systems, whereas large power producing engines like a car, bus, truck, etc. are equipped with water cooling systems.

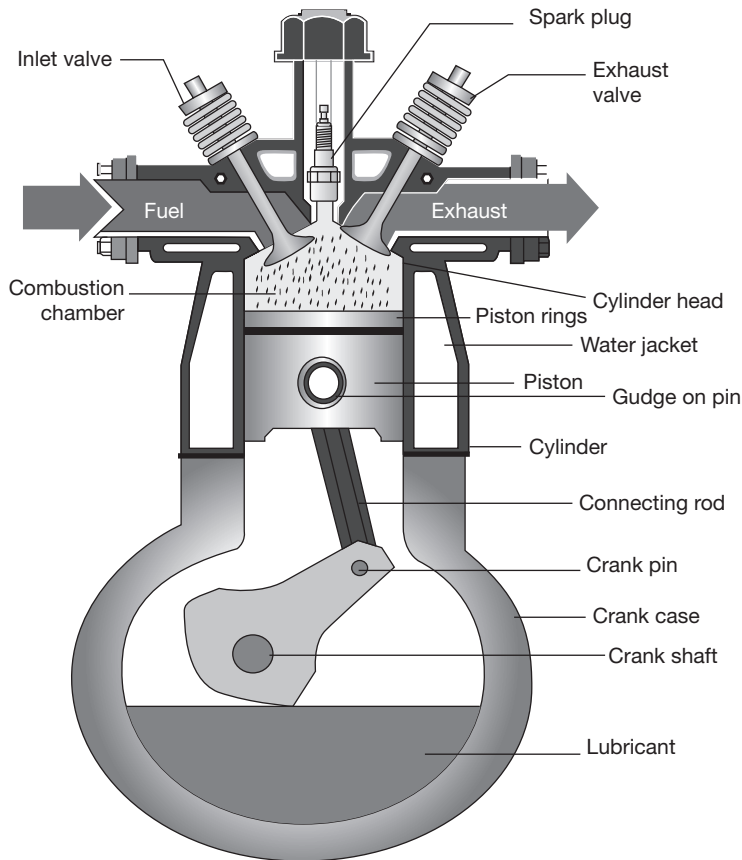
**Fuel Supply Systems:** On the basis of fuel supply systems, I.C. Engines can be classified as:

- (a) Carburetor engine,
- (b) Air injection engine, and
- (c) Airless or solid or Mechanical injection engines.

In a carburetor engine, air and fuel are properly mixed into the carburetor and then fed into the cylinder. In air injection engines, fuel is supplied to the cylinder with the help of compressed air. In mechanical injection engines, the fuel is injected into the cylinder with the help of mechanical pump and nozzle.

### 6.3 ► BASIC STRUCTURE OF I.C. ENGINES

Even though reciprocating internal combustion engines look very simple in appearance, they are highly complex machines. There are a large number of components which have to perform their functions to produce power. Before going through the working principle of the complex machine, a brief description of the engine components as shown in Figure 6.2, are given below as:



**FIGURE 6.2**

The Components of an I.C. Engine

- A. **Cylinder:** It is a hollow cylindrical structure closed at one end with the cylinder head. The combustion of the fuel takes place inside the cylinder. This is known as the heart of the engine. It is made of hard and high thermal conductivity materials by casting. A piston reciprocates inside the cylinder and produces power.
- B. **Cylinder Head:** It covers one end of the cylinder and consists of valves/ports and spark plug/injector.
- C. **Cylinder Liner:** The internal surface of the cylinder is equipped with a replaceable liner, which can be easily replaced after wear and tear. The liner is used to protect the wear of the cylinder so that replacement of complete cylinder can be avoided.
- D. **Piston:** It is a cylindrical component which is fitted perfectly inside the cylinder providing a gas-tight space with the piston rings and the lubricant. The piston is connected to connecting rod by hardened gudgeon pin. The main function of the piston is to transfer the power produced by combustion of the fuel to the crankshaft.
- E. **Piston Rings:** The outer periphery of the piston is provided with several grooves into which piston rings are fitted. The piston is fitted with these rings. The upper ring is known as compression ring and the lower rings are known as oil rings. The function of the compression ring is to compress the air or air-fuel mixture and the function of the oil rings is to collect the surplus lubricating oil on the liner surface.
- F. **Water Jacket:** Water jacket is an integral part of the cylinder through which cooling water is circulated to prevent the overheating the engine.
- G. **Connecting Rod:** It connects the piston and the crankshaft. One end, called the small end, is connected to the gudgeon pin located in the piston and the other end, called big end, is connected to crank pin. The function of the connecting rod is to transfer the reciprocating motion of the piston into rotary motion of the crankshaft.
- H. **Crankshaft:** It is principal rotating part of the engine which controls the sequence of reciprocating motion of the pistons. It consists of several bearings and crank pins.
- I. **Valves:** Normally, the two valves are used for each cylinder, which may be of mushroom shaped poppet type. They are provided either on the cylinder head or on the side of the cylinder for regulating the charge coming into the cylinder and for discharging the products of combustion from the cylinder. The valve mechanism consists of cams, cam follower, push rod, rocker arms, and spring.
- J. **Inlet Manifold:** This is the pipe which connects the intake system to the inlet valve of the engine and through which air or air-fuel mixture is drawn into the cylinder.
- K. **Exhaust Manifold:** This is the pipe which connects the exhaust system to the exhaust valve of the engine and through which products of combustion escapes into the atmosphere.
- L. **Cams and Camshaft:** Cam is mounted on a shaft which is known as the camshaft. The function of the cam is to facilitate the control of the timing of opening and closing of

the inlet and exhaust valve. It provides to and fro motion to the valve rods to open and close the valves.

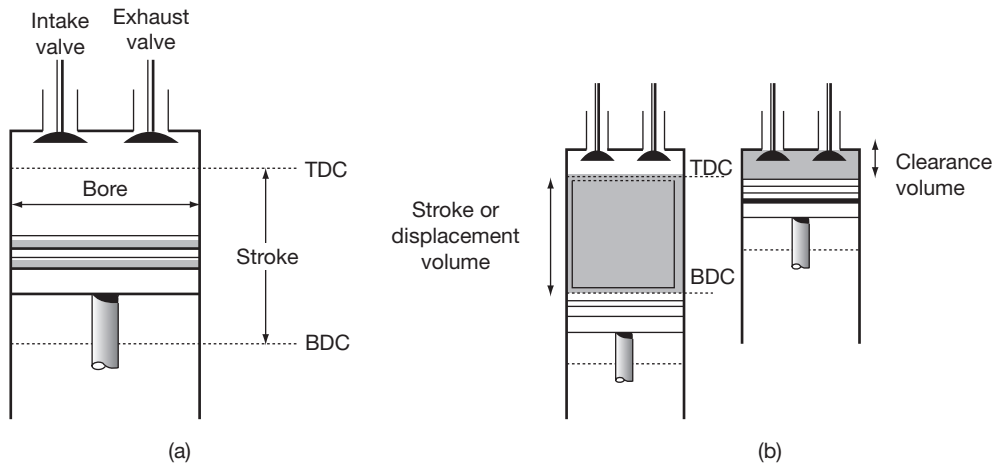
- M. **Spark Plug:** In an S.I engine, a spark plug is located near the top of the cylinder and initiates the combustion of the fuel.
- N. **Carburetor:** Carburetor is a device which is used to control the fuel qualitatively in an S.I engine. It atomizes the fuel, mixes with air and vaporizes it and finally sends the air-fuel mixture inside the cylinder through the inlet valve.
- O. **Fuel Pump and Injector Unit:** This unit is used in C.I. engines (nowadays injection system is also used in S.I. engine as multi-point fuel injection, MPFI). Its function is to supply the fuel to injector under pressure which consists of one or more orifices through which the fuel is sprayed into the cylinder.
- P. **Crankcase:** It consists of a cylinder, piston, and crankshaft. It helps in lubrication of different parts of the engine.
- Q. **Flywheel:** It is a heavy wheel mounted on the crankshaft to minimize the cyclic variations in speed. It absorbs the energy during the power stroke and releases it during the non-power stroke. By employing a flywheel, the turning moment becomes uniform at the crankshaft.

### 6.3.1 Nomenclature

There are various terms which are frequently used in an I.C. Engine are discussed below:

- A. **Cylinder Bore (d):** The nominal inner diameter of a cylinder is called a cylinder bore which is designated by an English letter 'd' and expressed in millimeter (mm).
- B. **Piston Area (A):** The area of the inner diameter of a cylinder is known as piston area. It is measured in terms of a square centimeter (cm<sup>2</sup>) or square millimeter (mm<sup>2</sup>).
- C. **Stroke (L):** The axial distance for which a piston moves inside a cylinder in one stroke is known as stroke or stroke length (Figure 6.3) which is designated by an English letter 'L' and measured in terms of a millimeter (mm).
- D. **Dead Centers:** The positions of the piston, at the moments when the direction of the piston motion is reversed are known as dead centers. There are two dead centers—Top dead center (TDC) and Bottom dead center (BDC). The farthest position of the piston head from the crankshaft is known as TDC and nearest position of the piston head from the crankshaft is known as BDC as shown in Figure 6.3.
- E. **Displacement/Stroke/Swept Volume (Vs):** The nominal volume swept by the working piston when traveling from one dead center to the other is called the displacement volume. It is expressed in terms of a cubic centimeter (cc) and is given by

$$V_s = A \times L = \frac{\pi}{4} d^2 L$$



**FIGURE 6.3**

Stroke Length and Stroke Volume in an I.C. Engine

- F. **Clearance Volume ( $V_c$ ):** The nominal volume of the combustion chamber above the piston when it is at the at the TDC is known as clearance volume ( $V_c$ ) and is expressed in cc.
- G. **Compression Ratio ( $r_v$ ):** It is the ratio of the total cylinder volume when the piston is at BDC to the clearance volume.

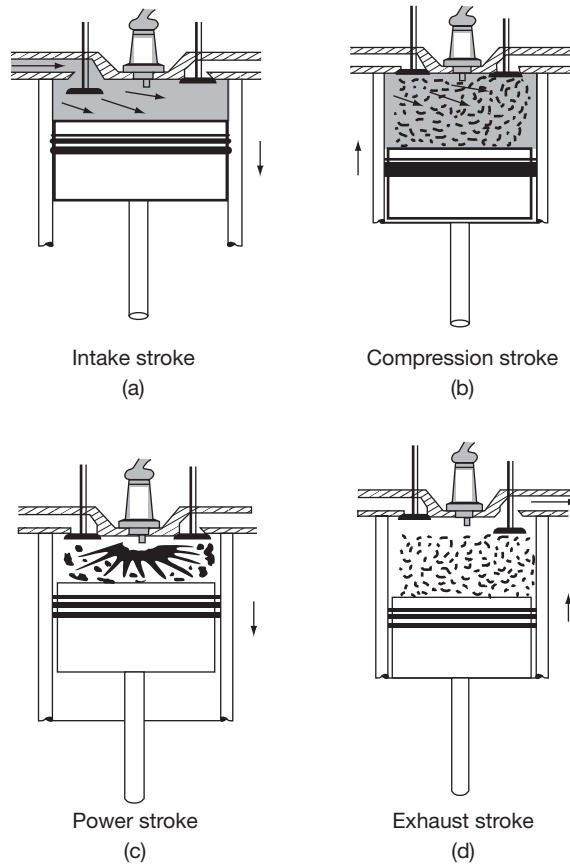
$$r_v = \frac{V_c + V_s}{V_c} = 1 + \frac{V_s}{V_c}$$

## 6.4 ► WORKING PRINCIPLE OF I.C. ENGINES

The working principle of an I.C. engine consists of thermodynamic cycle involved to generate the power and thermodynamic processes such as suction, compression, heat addition expansion, and heat rejection. In this chapter, we will study the operating principles of four strokes and two strokes of spark ignition engine and compression ignition engine.

### 6.4.1 Four-stroke Spark Ignition Engine

The working of all the four strokes of a spark ignition engine is shown in Figure 6.4. In this engine, the cycle of operations is completed in 4-strokes of the piston or two revolutions of the crankshaft. During the 4-strokes, there are five processes to be completed, viz., suction, compression, combustion, expansion, and exhaust. Each stroke consists of  $180^\circ$  rotation of

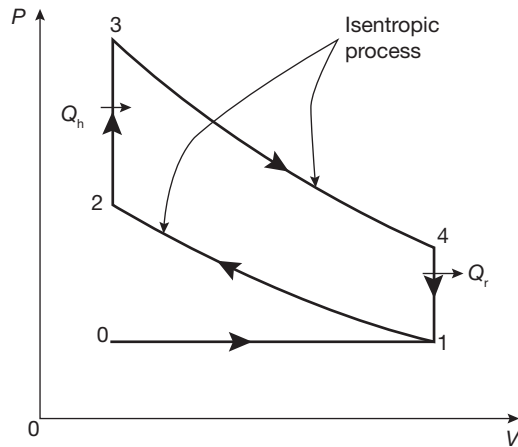
**FIGURE 6.4**

All the Four Thermodynamic Processes in Four-stroke S.I. Engine

the crankshaft and hence a 4-strokes cycle is completed in two revolutions of the crankshaft. The pressure-volume diagram (P-V diagram) diagram is shown in Figure 6.5.

**Suction Stroke (0-1):** It starts when the piston is at TDC and about to move downward, the inlet valve is open, and the exhaust valve is closed as shown in Figure 6.4 (a). Due to suction created by the piston movement towards BDC, air-fuel mixture enters into the cylinder, and the suction ends when the piston reaches the BDC.

**Compression Stroke (1-2):** At the end of the suction stroke, the inlet valve is closed and the piston moves towards TDC. In this stroke, both the valves, inlet and exhaust are closed; compression of the air-fuel mixture filled in the cylinder starts from BDC and ends at TDC as shown in Figure 6.4 (b). At the end of compression and at constant volume (2-3), sparking



**FIGURE 6.5**

P-V Diagram for Otto Cycle

starts at the spark plug and instantaneously burning takes place in the compressed air-fuel mixture. Pressure and temperature are increased to the maximum limit.

**Power Stroke (3-4):** The high pressure developed due to combustion of fuel forces the piston towards BDC. The power is transferred to the crankshaft. Pressure and temperature decrease during the stroke. In this stroke, both the valves are closed as shown in Figure 6.4 (c).

**Exhaust Stroke (4-1):** At the end of expansion or power stroke, the exhaust valve opens and the inlet valve remains closed as shown in Figure 6.4 (d). Piston moves towards TDC and exhaust gas is forced to escape into the atmosphere through the exhaust valve.

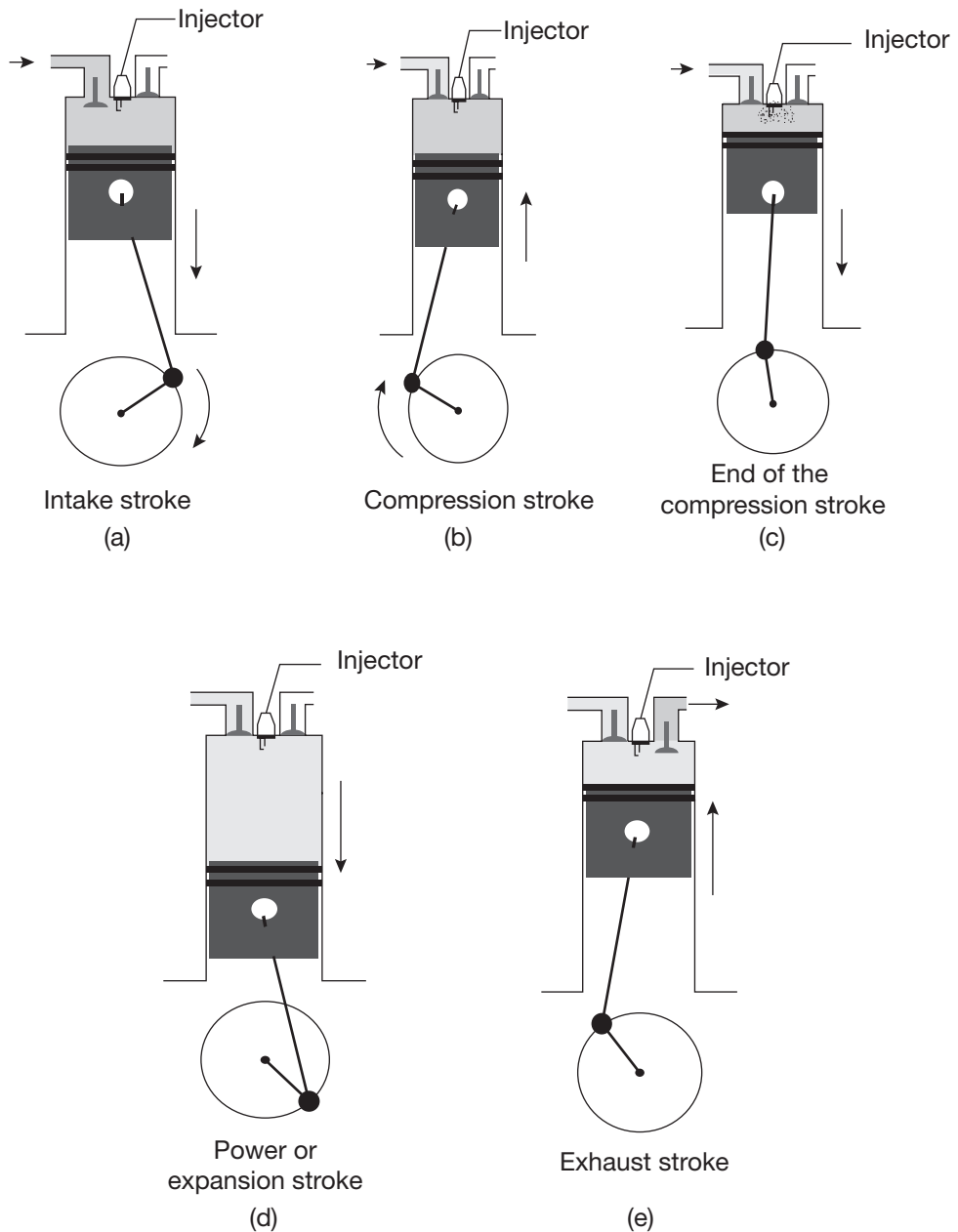
### 6.4.2 Four-stroke Compression Ignition Engine

The four-stroke compression ignition (C.I. Engine) is very similar to the four-stroke spark ignition engine as shown in Figure 6.6, but it operates at a much higher compression ratio. The compression ratio of S.I. Engine varies from 6 to 10 whereas in C.I. Engines it ranges from 16 to 20. During the suction stroke, air is sucked alone inside the cylinder and then compressed sufficiently to increase the temperature equal to the self-ignition temperature of the fuel injected at the end of compression at constant pressure. In this engine, a fuel pump and injector are used to inject the fuel at high pressure. The ignition system of the C.I. Engine is completely different from S.I. engine as no spark plug and carburetor are required.

The sequence of operations of the C.I. Engine can be explained as:

- **Suction Stroke:** In this stroke, the piston moves from TDC to BDC and air is sucked alone as the vacuum is created inside the cylinder by the piston movement. During suction inlet

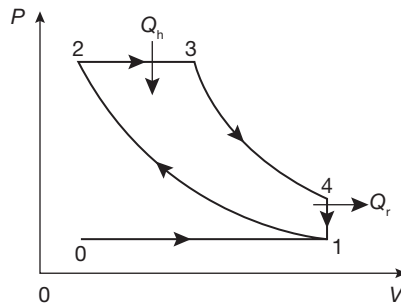
valve is open and exhaust valve remains closed as shown in Figure 6.6 (a). On the ideal P-V diagram, the suction is shown by a straight line from 0 to 1 in Figure 6.7.



**FIGURE 6.6**

All the Thermodynamic Processes in Four-stroke C.I. Engine





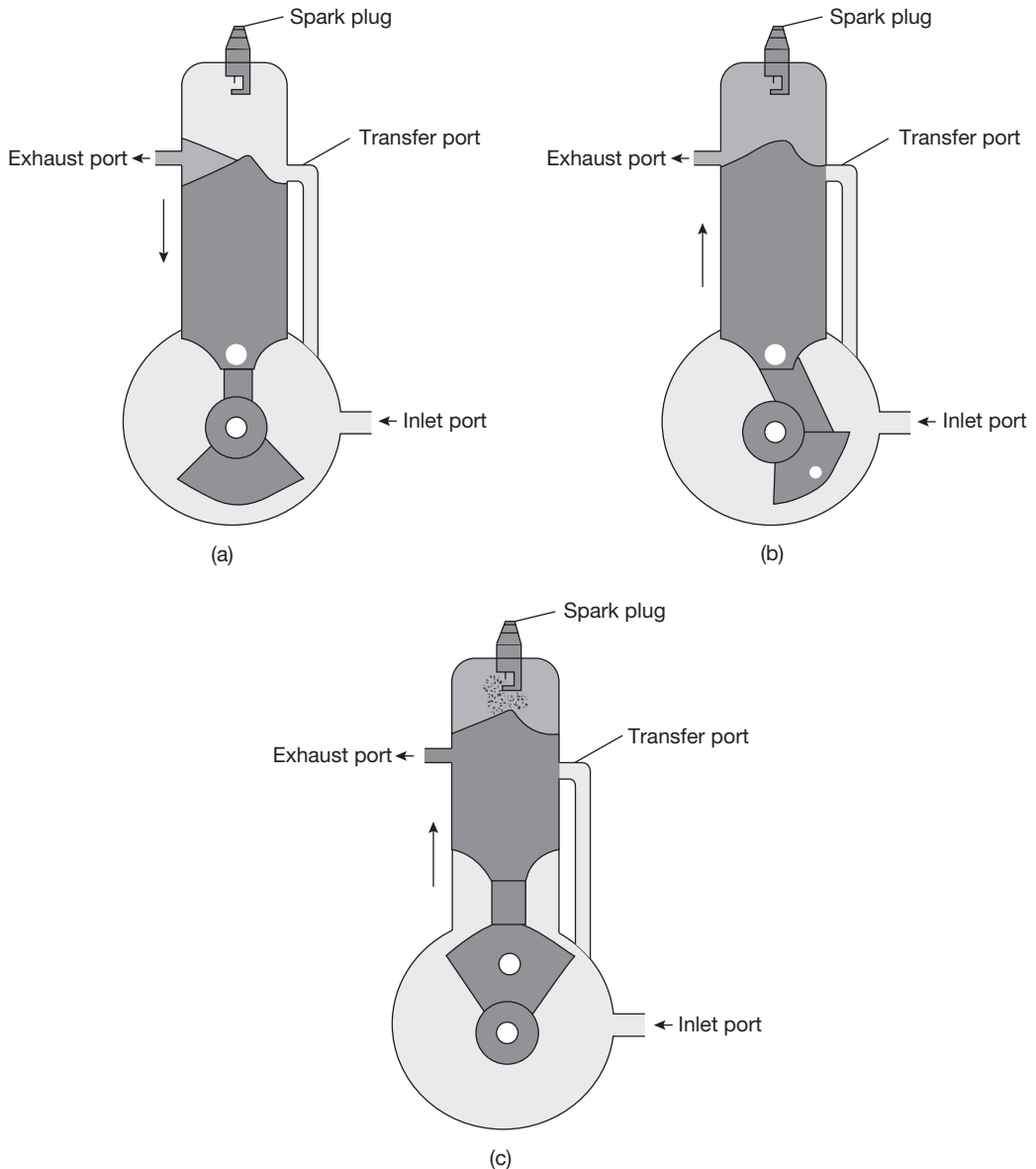
**FIGURE 6.7**

P-V Diagram for Diesel Cycle

- ▶ **Compression Stroke:** Both the valves are closed during the stroke and air is compressed into the clearance volume by the piston movement from BDC to TDC as shown in Figure 6.6 (b). In the P-V diagram, it is shown by the process 1-2 in Figure 6.7. At the end of compression at constant pressure fuel is injected as shown in Figure 6.6(c). Due to high pressure and temperature, fuel starts to ignite automatically as temperature of the air is increased to the flash point of the fuel. The heat addition process is shown by the line 2-3 on P-V diagram.
- ▶ **Expansion or Power Stroke:** Fuel injection starts nearly at the end of the compression stroke. The rate of injection is such that the combustion maintains the pressure constant in spite of the piston movement on its expansion stroke increasing the volume. Heat is assumed to have been added at constant pressure. After the injection of the fuel is completed (after cut-off) the combustion products expand. Both valves remain closed during the expansion stroke as shown in Figure 6.6 (d). The expansion process is shown by 3-4 on P-V diagram.
- ▶ **Exhaust Stroke:** The exhaust valve is open and the inlet valve is closed during the stroke. The movement of the piston from BDC to TDC pushes the product of combustion and disposed into the atmosphere through the exhaust valve as shown in Figure 6.6 (e). The exhaust process is shown by the line 4-5 on P-V diagram.

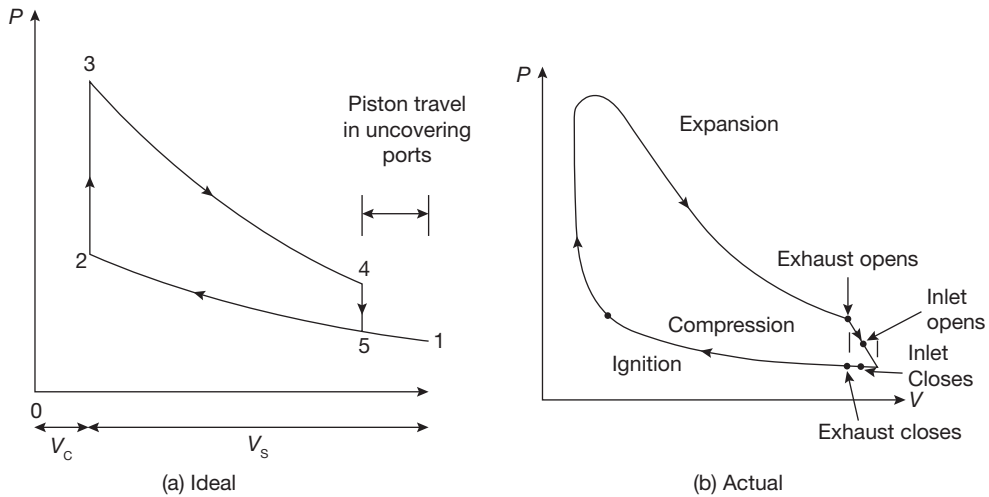
### 6.4.3 Two-stroke Spark Ignition Engine

In a four-stroke S.I. engine, there is one power stroke in two revolutions of the crankshaft and two strokes, viz., suction and exhausts are nonproductive. If these two nonproductive strokes could be served by an alternative arrangement, especially without movement of the piston then there will be one power stroke for each revolution of the crankshaft. In such an engine, the power output can be doubled, theoretically, for the same speed compared to four-stroke engine. Based on this concept, D. Clark (1878) developed the two-stroke engine.

**FIGURE 6.8**

Working of Two-stroke S.I. Engine

In this engine, the filling process is accomplished by the charge compression in the crankcase or by a blower. The induction of the compressed charge pushes the burnt fuel products through the exhaust port. Therefore, no piston movement is required for suction and exhaust process. Two strokes are sufficient to complete the cycle, one for compressing the

**FIGURE 6.9**

P-V Diagrams for Two-stroke S.I. Engine

fresh charge and other for expansion or power stroke. Figure 6.8 shows the simplest form of crankcase-scavenged engine. The ideal and actual indicator diagram is shown in Figure 6.9.

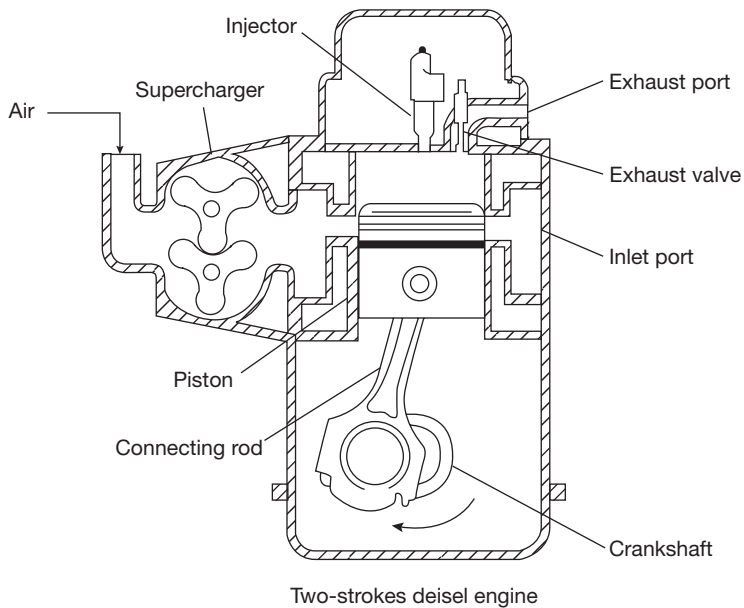
The charge is inducted into the crankcase through the spring loaded inlet valve when the pressure in the crankcase is reduced due to the upward movement of the piston during the compression stroke. After the compression and ignition, expansion takes place in the usual way. During expansion stroke, the charge in the crankcase is compressed. Near the end of the expansion stroke, piston uncovers the exhaust port and cylinder pressure drops to atmospheric pressure as combustion products leave the cylinder. Further movement of piston uncovers the transfer port, permitting the slightly compressed charge in the crankcase to enter the engine cylinder.

The top of the piston has usually a projection to deflect the fresh charge towards the top of the cylinder before flowing to the exhaust port. This serves the double purpose—scavenging the combustion product in the upper part of the cylinder and preventing the fresh charge from flowing directly to the exhaust port. The same objective can be achieved without piston deflector by proper shaping of the transfer port. During the upward motion of the piston from BDC the transfer port is closed first and then the exhaust port is closed when compression of charge begins and the cycle is repeated in the same way.

#### 6.4.4 Two-stroke C.I. Engine

The working of two-stroke C.I. engine is very similar to two-stroke S.I. engine. The main difference is that in C.I. engine supercharged air is used through the inlet port and in place

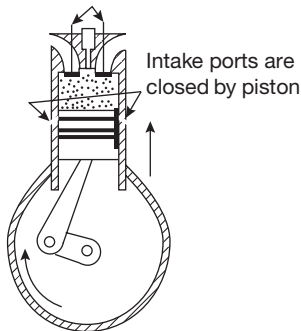
of exhaust port exhaust valves are used. Pressurized air is inducted through the inlet port, which expels the combustion gases through the exhaust valve during the expansion stroke. Inlet and exhaust valve is closed during the compression stroke, the piston moves from BDC to TDC. At the end of compression, fuel is injected into the cylinder and ignites and the piston is forced to move from TDC to BDC. The same process is repeated again and again. The cut model of two-stroke C.I. engine is shown in Figure 6.10 and the working strokes are shown in Figure 6.11.



**FIGURE 6.10**

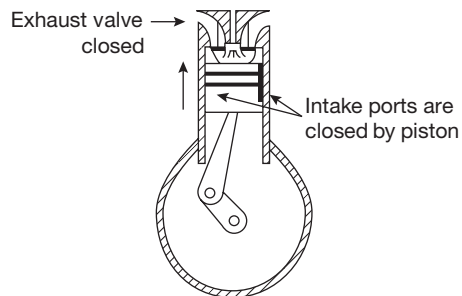
Cut-section of Two-stroke C.I. Engine

Exhaust valves closed

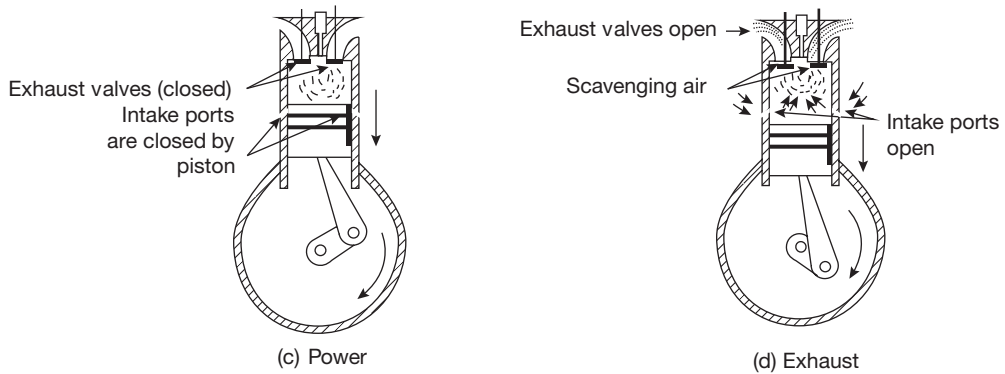


(a) Compression

Fuel injector



(b) Injection

**FIGURE 6.11**

Working of Two-stroke C.I. Engine

### 6.4.5 Comparison Between Four-stroke and Two-stroke Engines

**Table 6.1: Comparison between four-stroke and two-stroke engines**

Four-stroke Engines	Two-stroke Engines
1. The thermodynamic cycle is completed in four strokes of the piston and two revolutions of the crankshaft. Thus, one power stroke is obtained in two revolutions of the crankshaft.	1. The thermodynamic cycle is completed in two strokes of the piston and one revolution of the crankshaft. Thus, one power stroke is obtained in one revolution of the crankshaft.
2. Turning moment is not so uniform during all the four strokes and hence, the heavier flywheel is required.	2. Comparatively, turning moment is more uniform and hence lighter flywheel can be employed.
3. The power produced from same size engine is less than two-stroke engine due to one power stroke in two revolutions of the crankshaft. Or for same power output engine required is heavier and bulkier.	3. The power produced from same size engine is more than the four-stroke engine due to one power stroke in each revolution of the crankshaft.
4. Less cooling and lubrication is required due to one power stroke in two revolutions and hence less wears and tear occurs.	4. Larger cooling and lubrication is required due to one power stroke in each revolution and hence more wear and tear occurs.
5. It consists of valves and valve actuating mechanism such as cam, camshaft, rocker arm, spring, valve, and valve seat.	5. It has ports in place of valves.
6. It has higher volumetric efficiency as the time available for induction of charge is more.	6. Volumetric efficiency is lower due to lesser time available for induction.
7. It has a higher thermal efficiency due to complete combustion of the fuel.	7. It has a lower thermal efficiency due to the partial wastage of fuel through the exhaust port and incomplete combustion.

## 6.4.6 Comparison Between S.I. and C.I. Engines

**Table 6.2(a): Comparison between S.I. and C.I. engines**

S.I. Engines	C.I. Engines
1. It is based on Otto cycle or constant volume heat addition and rejection cycle.	1. It is based on a Diesel cycle or constant pressure heat addition and constant volume heat rejection cycle.
2. A high volatile and high self-ignition temperature fuel, i.e., gasoline is used.	2. Comparatively low volatile and low self-ignition temperature fuel, i.e., diesel is used.
3. A gaseous mixture of fuel and air is inducted during the suction stroke. A carburetor is necessary to provide the mixture.	3. Fuel is injected at high pressure at the end of compression stroke. A fuel pump and injector units are used.
4. Throttle controls the quantity of fuel-air mixture introduced.	4. The quantity of fuel is regulated in the pump. Air quantity is not controlled. There is quality control.
5. For combustion of the charge, it requires an ignition system with a spark plug in the combustion chamber.	5. Autoignition occurs due to the high-temperature of air resulting from high-compression.
6. Compression ratio ranges from 6 to 10.	6. Compression ratio ranges from 16 to 20.
7. Due to light weight and homogeneous combustion, they are high-speed engines.	7. Due to heavy weight and heterogeneous combustion, they are comparatively low-speed engines.
8. It has a lower thermal efficiency due to lower compression ratio but delivers more power for same compression ratio.	8. It has a higher thermal efficiency due to high-compression ratio and delivers lesser power for the same compression ratio.

## 6.4.7 Comparison Between Otto Cycle and Diesel Cycle

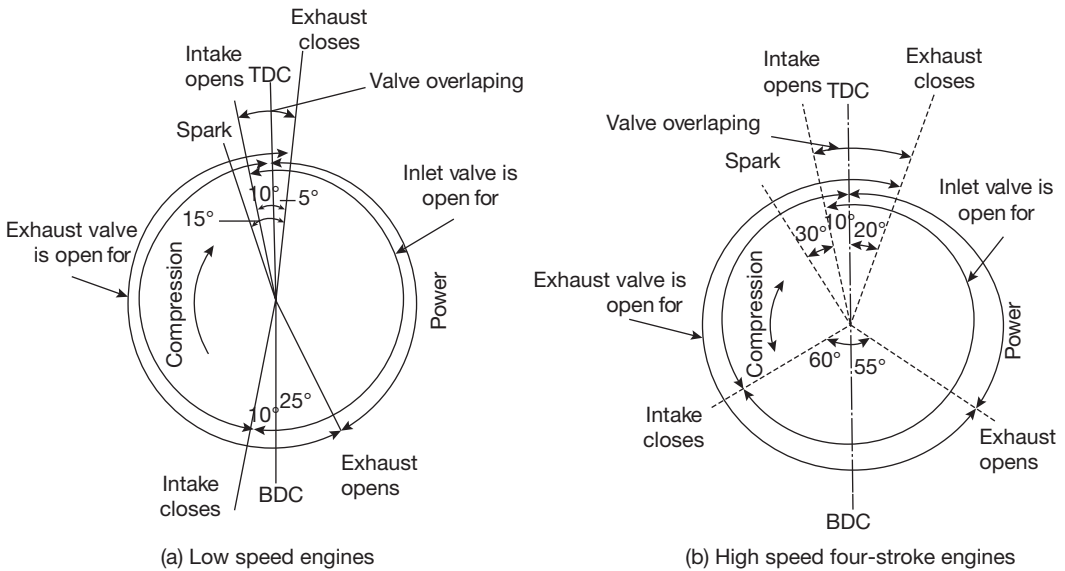
**Table 6.2 (b): Comparison between Otto Cycle and Diesel Cycle**

Otto Cycle	Diesel Cycle
1. In Otto cycle, heat added and rejected at constant volume.	1. In Diesel cycle, Heat is added at constant pressure and heat rejected at constant volume.
2. For the same compression ratio, Otto cycle is more efficient than that of Diesel cycle.	2. The compression ratio of Diesel cycle is more than that of the Otto cycle.
3. Otto cycle is used in S.I. Engines.	3. Diesel cycle is used in C.I. Engines.

## 6.5 ► VALVE TIMING DIAGRAMS

### 6.5.1 Valve Timing Diagram for Four-stroke S.I. Engines

The valve timing diagram is a graphical representation of valve opening and closing time with ignition time in terms of angle of crank revolution. Figure 6.12 shows the valve timing diagram for low speed four-stroke S.I. engines. Practically, the valve cannot be opened or closed at any sharp points. Therefore, the actual indicator diagram differs from the theoretical indicator diagram as shown in Figure 6.15.



**FIGURE 6.12**

Valve Timing Diagram for Four-stroke Engines

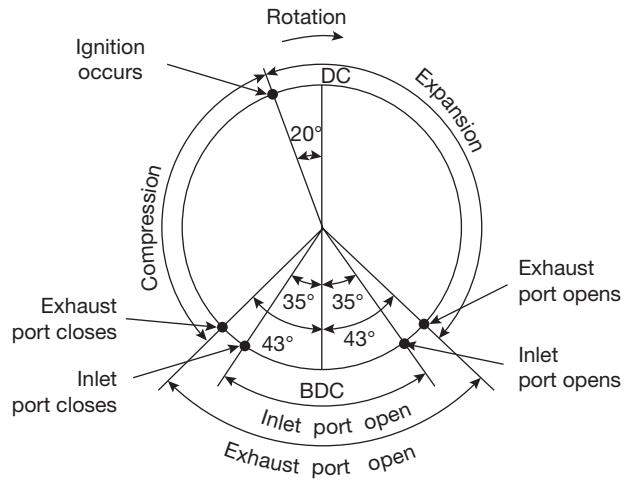
**Table 6.3: Theoretical and actual valve timing for four-stroke S.I. engines**

Valve activity	Theoretical timing	Actual timing for low-speed engines	Actual timing for high-speed engines
Inlet valve opens	TDC	10° before TDC	10° before TDC
Inlet valve closes	BDC	10° after BDC	60° after BDC
Inlet valve is open for	180°	200°	250°
Exhaust valve opens	BDC	25° before BDC	55° before BDC
Exhaust valve closes	TDC	5° after TDC	20° after TDC
Exhaust valve is open for	180°	210°	255°
Valve overlap	NIL	15°	30°
Spark	TDC	15° before TDC	30° before TDC

### 6.5.2 Port Timing Diagram for Two-stroke S.I. Engines

**Table 6.4: Port timing for two-stroke S.I. engines**

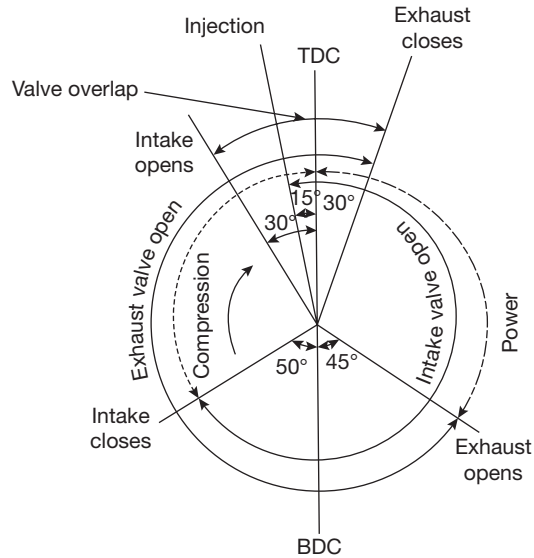
Position	Actual timing
Inlet port opens	35° before BDC
Inlet port closes	35° after BDC
Inlet port is open for	70°
Exhaust port opens	43° before BDC
Exhaust port closes	43° after BDC
Exhaust port is open for	86°
Overlap	70°
Spark	20° before TDC



**FIGURE 6.13**

Port Timing Diagram for Two-stroke S.I. Engines.

### 6.5.3 Valve Timing Diagram for Four-stroke C.I. Engines



**FIGURE 6.14**

Valve Timing Diagram for Four-stroke C.I. Engines

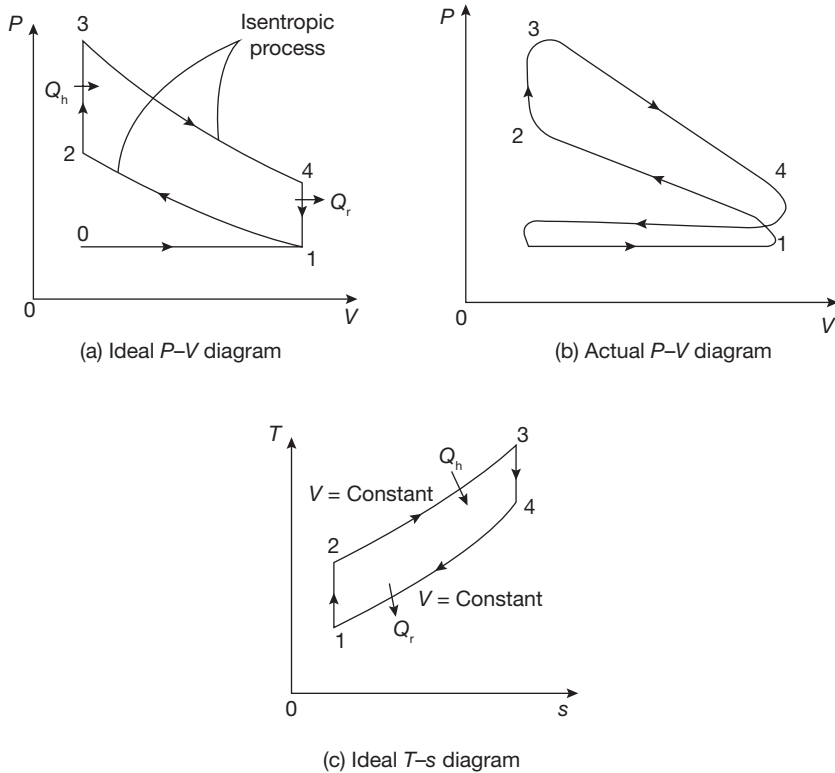


**Table 6.5: Valve timing for four-stroke C.I. engines**

Valve Activity	Theoretical Timing	Actual Timing
Inlet valve opens	TDC	30° before TDC
Inlet valve closes	BDC	50° after BDC
Inlet valve is open for	180°	260°
Exhaust valve opens	BDC	45° before BDC
Exhaust valve closes	TDC	30° after TDC
Exhaust valve is open for	180°	255°
Valve overlap	NIL	60°
Injection	TDC	15° before TDC

### 6.6 ► OTTO CYCLE

In Figure 6.14, Ideal P-V, actual P-V, and T-S diagrams are shown. There are some basic differences in ideal and actual indicator diagrams as valves do not open or close at sharp points practically. Valve start to open just before the point and closes just after the points



**FIGURE 6.15**

Indicator Diagrams for Otto Cycle

as shown in Figure 6.14 (b). The process 0-1 shows the suction of the charge which is compressed for 1-2. After compression heat is added at constant volume for 2-3. 3-4 is an isentropic expansion process at the end of expansion exhaust valve opens and heat is rejected for 4-1.

$$\text{Thermal efficiency of Otto Cycle, } \eta_{th} = \frac{Q_h - Q_r}{Q_h} = 1 - \frac{Q_r}{Q_h}$$

$$\eta_{th} = \frac{m C_v (T_3 - T_2) - m C_v (T_4 - T_1)}{m C_v (T_3 - T_2)} = 1 - \frac{m C_v (T_4 - T_1)}{m C_v (T_3 - T_2)} = 1 - \frac{T_1 \left( \frac{T_4}{T_1} - 1 \right)}{T_2 \left( \frac{T_3}{T_2} - 1 \right)}$$

$$\frac{T_2}{T_1} = \left( \frac{V_1}{V_2} \right)^{\gamma-1} = \left( \frac{V_4}{V_3} \right)^{\gamma-1} = \frac{T_3}{T_4}; \text{ where } \gamma = \frac{c_p}{c_v}$$

$$\frac{T_3}{T_2} = \frac{T_4}{T_1}; \quad \eta_{th} = 1 - \frac{T_1}{T_2}$$

$$r_k = \frac{V_1}{V_2} = \frac{V_4}{V_3}; \quad r_k = \frac{\text{Total volume}}{\text{Clearance volume}} = \frac{v_s + v_c}{v_c} \quad r_k = \frac{v_s}{v_c} + 1$$

$$\frac{T_1}{T_2} = \left( \frac{V_2}{V_1} \right)^{1-\gamma} = (r_k)^{1-\gamma}$$

$$\eta_{th} = 1 - (r_k)^{1-\gamma} = 1 - \frac{1}{(r_k)^{\gamma-1}}$$

### EXAMPLE 6.1

In an air-standard Otto cycle, the pressure and temperature at the start of the compression stroke are 0.1 MPa and 300 K, respectively. The temperature at the end of the compression and at the end of the heat addition processes are 600 and 1,600 K, respectively. Calculate: (i) thermal efficiency, (ii) heat added, (iii) net work per kg of air, and (iv) mean effective pressure.

**SOLUTION**

Given  $P_1 = 0.1 \text{ MPa}$ ,  $T_1 = 300 \text{ K}$ ,  $T_3 = 1600 \text{ K}$ ,  $\gamma_{\text{air}} = 1.4$ ,  $R = 0.287 \text{ kJ/kgK}$ .

For 1 kg of air,  $P_1 V_1 = RT_1$  or  $V_1 = \frac{RT_1}{P_1} = \frac{0.287 \text{ kJ/kgK} \times 300 \text{ K}}{1 \times 10^2 \text{ kPa}} = 0.861 \text{ m}^3$ ;

$$V_2 = V_1 \left( \frac{T_1}{T_2} \right)^{\frac{1}{\gamma-1}} = 0.1522 \text{ m}^3$$

Compression ratio,  $r_k = \frac{V_1}{V_2} = 5.65$ ;  $\eta_{\text{Otto}} = 1 - \frac{1}{(r_k)^{\gamma-1}} = 0.5$

Heat added at constant volume,  $Q_h = C_v(T_3 - T_2) = 0.718 \text{ kJ/kg}(1600 \text{ K} - 600 \text{ K})$   
 $= 718 \text{ kJ/kg}$

$$W_{\text{net}} = Q_h \times \eta_{\text{Otto}} = 0.718 \text{ kJ/kg} \times 0.5 = 359 \text{ kJ/kg}$$

Mean effective pressure,  $P_m = \frac{W_{\text{net}}}{V_1 - V_2} = \frac{359 \text{ kJ/kg}}{0.861 \text{ m}^3 - 0.1522 \text{ m}^3} = 506.48 \text{ kN/m}^2$   
 $= 0.506 \text{ Mpa.}$

**EXAMPLE 6.2**

An engine operation on an air-standard Otto cycle has a compression ratio equal to 7. The conditions at the start of compression are 0.1 MPa and 300 K. The pressure at the end of heat addition is 4 MPa. Determine: (i) thermal efficiency, (ii) net work done per kg of air where  $C_v = 0.718 \text{ kJ/kg}$ ,  $\gamma_{\text{air}} = 1.4$ , and (iii) mean effective pressure.

**SOLUTION**

Given,  $P_1 = 0.1 \text{ MPa}$ ,  $T_1 = 300 \text{ K}$ ,  $P_3 = 4 \text{ MPa}$ ,  $r_{\text{air}} = 7$

$$\eta_{\text{Otto}} = 1 - \frac{1}{(r_k)^{\gamma-1}} = 1 - \frac{1}{7^{0.4}} = 0.54 = 54\%$$

$$T_2 = T_1 \left( \frac{V_1}{V_2} \right)^{\gamma-1} = 300 \text{ K}(7)^{0.4} = 653.37 \text{ K}; P_2 = P_1 \left( \frac{V_1}{V_2} \right)^{\gamma} = 100 \text{ kPa}(7)^{1.4} = 1524.53 \text{ kN/m}^3.$$

$$\text{Process } 2-3: T_3 = T_2 \times \frac{P_3}{P_2} = \frac{4000 \text{ kPa}}{1524.23 \text{ kPa}} \times 653.37 \text{ K} = 1714.28 \text{ K}$$

$$Q_h = C_v(T_3 - T_2) = 0.718 \text{ kJ/kgK}(1714.28 \text{ K} - 653.37 \text{ K}) = 761.73 \text{ kJ/kg}$$

$$W_{net} = Q_h \times \eta_{Otto} = 761.73 \text{ kJ/kg} \times 0.54 = \mathbf{411.338 \text{ kJ/kg}}$$

$$\text{Mean effective pressure, } P_m = \frac{W_{net}}{V_1 - V_2} = \frac{411.338 \text{ kJ/kg}}{0.861 \text{ m}^3 - 0.123 \text{ m}^3} = \mathbf{0.557 \text{ MPa}}$$

### EXAMPLE 6.3

Derive the expression for compression ratio, in Otto cycle, for maximum work done in terms of maximum and minimum temperatures.

### SOLUTION

Refer Figure 6.10c, Maximum and minimum temperatures in the cycle are  $T_3$  and  $T_1$ , respectively.

$$\begin{aligned} W_{net} &= Q_h - Q_r = C_v \{(T_3 - T_2) - (T_4 - T_1)\} = C_v \{(T_1 - T_2) + (T_3 - T_4)\} \\ &= C_v \left\{ T_1 \left(1 - r_k^{\gamma-1}\right) + T_3 \left(1 - \frac{1}{r_k^{\gamma-1}}\right) \right\} \end{aligned}$$

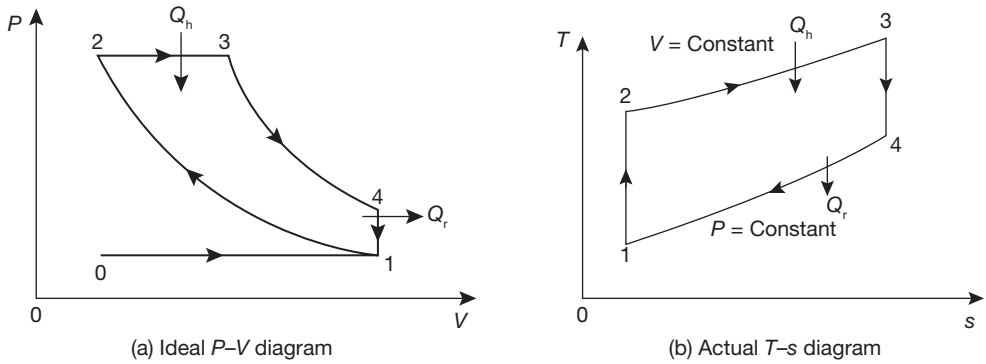
$$\text{For maximum work, } \frac{d(W_{net})}{dr_k} = 0$$

$$\text{i.e. } -T_1 C_v (\gamma-1) r_k^{\gamma-2} - T_3 C_v (1-\gamma) r_k^{-\gamma} = 0$$

$$\frac{T_3}{T_1} = r_k^{2(\gamma-1)} \quad \text{or} \quad r_k = \left( \frac{T_3}{T_1} \right)^{\frac{1}{2(\gamma-1)}}$$

## 6.7 ► DIESEL CYCLE

In a Diesel cycle, heat is added at constant pressure and rejected at constant volume as shown in Figure 6.16. During heat addition, to maintain the constant pressure piston starts to move towards BDC. A point 3, injection is stopped which is known as the cut-off point.


**FIGURE 6.16**

Indicator Diagrams for Diesel Cycle

Thermal efficiency of Diesel cycle,  $\eta_{th} = \frac{Q_h - Q_r}{Q_h} = 1 - \frac{Q_r}{Q_h}$

$$Q_h = m C_p (T_3 - T_2); \quad Q_r = m C_v (T_4 - T_1)$$

$$Q_h = m C_p (T_3 - T_2); \quad Q_r = m C_v (T_4 - T_1)$$

$$\eta_{th} = 1 - \frac{m C_v (T_4 - T_1)}{m C_p (T_3 - T_2)};$$

For isentropic compression process 1-2;  $\frac{T_2}{T_1} = \left(\frac{V_1}{V_2}\right)^{\gamma-1} = (r_k)^{\gamma-1}; T_2 = T_1 (r_k)^{\gamma-1}$

For constant pressure heat addition process 2-3;  $\frac{T_3}{T_2} = \frac{V_3}{V_2} = r_c; T_3 = T_2 r_c$

Thus,  $T_3 = T_1 (r_k)^{\gamma-1} r_c$ ;

$$T_4 = T_3 \left(\frac{V_3}{V_4}\right)^{\gamma-1} = T_3 \left(\frac{V_3}{V_2} \times \frac{V_2}{V_4}\right)^{\gamma-1} = T_3 \left(\frac{r_c}{r_k}\right)^{\gamma-1} = T_1 (r_k)^{\gamma-1} r_c \left(\frac{r_c}{r_k}\right)^{\gamma-1} = T_1 r_c^\gamma$$

Putting the value of  $T_2$ ,  $T_3$ , and  $T_4$  in the equation of Efficiency, we get

$$\eta_{th} = 1 - \frac{1}{(r_k)^{\gamma-1}} \left[ \frac{(r_c)^\gamma - 1}{\gamma(r_c - 1)} \right]$$

**EXAMPLE 6.4**

In an air standard diesel cycle, the compression ratio is 18. The pressure and temperature at the beginning of compression are 0.1 MPa and 300 K, respectively. Heat is added at constant pressure until the temperature is increased to 1700 K. Calculate: (i) cut-off ratio, (ii) heat supplied per kg of air, (iii) cycle efficiency, and (iv) mean effective pressure  $C_p = 1.005 \text{ kJ/kg}$ ,  $\gamma_{\text{air}} = 1.4$ .

**SOLUTION**

Given,  $r_k = \frac{V_1}{V_2} = 18$ ,  $P_1 = 0.1 \text{ MPa}$ ,  $T_1 = 300 \text{ K}$ ,  $T_3 = 1700 \text{ K}$ .

$$\frac{T_2}{T_1} = \left( \frac{V_1}{V_2} \right)^{\gamma-1} = (r_k)^{\gamma-1}; T_2 = T_1 (r_k)^{\gamma-1} = 300 \text{ K} (18)^{0.4} = 953.3 \text{ K}$$

$$V_1 = \frac{RT_1}{P_1} = \frac{0.287 \text{ kJ/kgK} \times 300 \text{ K}}{100 \text{ kPa}} = 0.861 \text{ m}^3; V_2 = \frac{V_1}{r_k} = 0.047 \text{ m}^3$$

Cut-off ratio,  $r_c = \frac{V_3}{V_2} = \frac{T_3}{T_2} = \frac{1700 \text{ K}}{953.3 \text{ K}} = \mathbf{1.78}$

Heat addition at constant pressure,

$$\begin{aligned} Q_h &= m C_p (T_3 - T_2) = 1.005 \text{ kJ/kg} (1700 \text{ K} - 953.3 \text{ K}) \\ &= \mathbf{750.43 \text{ kJ/kg}} \end{aligned}$$

$$\begin{aligned} \eta_{\text{th}} &= 1 - \frac{1}{(r_k)^{\gamma-1}} \left[ \frac{(r_c)^{\gamma} - 1}{\gamma(r_c - 1)} \right] = 1 - \frac{1}{(18)^{0.4}} \left[ \frac{(1.78)^{1.4} - 1}{1.4(1.78 - 1)} \right] \\ &= 0.642 = \mathbf{64.2\%} \end{aligned}$$

$$W_{\text{net}} = Q_h \times \eta_{\text{Diesel}} = 750.43 \text{ kJ/kg} \times 0.642 = 481.88 \text{ kJ/kg}$$

Mean effective pressure,  $P_m = \frac{W_{\text{net}}}{V_1 - V_2} = \mathbf{0.592 \text{ MPa}}$

**EXAMPLE 6.5**

An ideal diesel cycle operates on 1 kg of standard air with an initial pressure of 0.98 bar and a temperature of 35°C. The pressure at the end of compression is 33 bar and the cut-off is 6% of the stroke. Determine: (i) compression ratio, (ii) percentage clearance, and (iii) heat supplied.

**SOLUTION**

Given,  $P_1 = 0.98 \text{ bar}$ ,  $T_1 = 273 + 33 = 308\text{K}$ ,  $P_2 = 33 \text{ bar}$ .

$$V_1 = \frac{RT_1}{P_1} = \frac{0.287 \text{ kJ/kgK} \times 308 \text{ K}}{0.98 \times 10^2 \text{ kPa}} = 0.902 \text{ m}^3; \quad V_2 = V_1 \left( \frac{P_1}{P_2} \right)^{\frac{1}{\gamma}}$$

$$= 0.902 \text{ m}^3 \times \left( \frac{0.98 \times 10^2 \text{ kPa}}{33 \times 10^2 \text{ kPa}} \right)^{\frac{1}{1.4}} = 0.07318 \text{ m}^3$$

$$T_2 = T_1 \left( \frac{V_1}{V_2} \right)^{\gamma-1} = 841.98 \text{ K};$$

Compression ratio,  $r_k = \frac{V_1}{V_2} = \mathbf{12.325}$

$$\text{Percentage clearance} = \frac{V_2}{V_2 + V_5} \times 100 = \frac{0.073 \text{ m}^3}{0.902 \text{ m}^3} \times 100 = 0.08 \times 100 = \mathbf{8\%}$$

Cut-off volume =  $0.06 \times$  stroke volume

$$V_3 - V_2 = 0.06 (V_1 - V_2); \quad V_3 = 0.06 (12.325 V_2 - V_2) + V_2 = 1.679 V_2$$

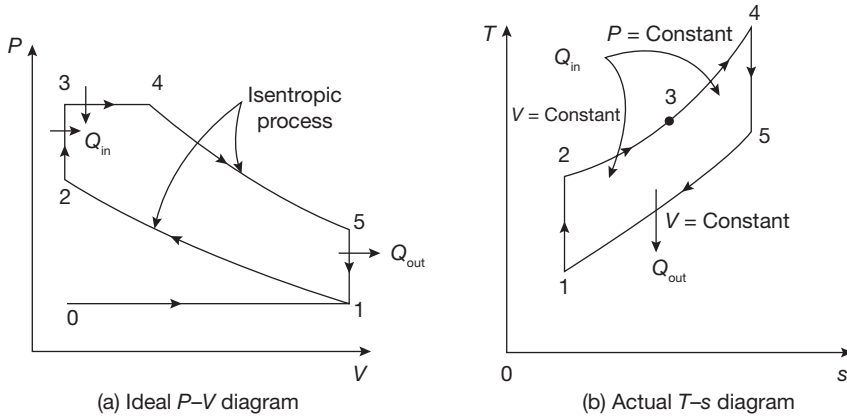
$$\text{or } \frac{V_3}{V_2} = 1.679;$$

$$\text{Heat supplied, } Q_h = C_p (T_3 - T_2) = C_p T_2 \left( \frac{T_3}{T_2} - 1 \right) = C_p T_2 \left( \frac{V_3}{V_2} - 1 \right)$$

$$= 1.005 \text{ kJ/kgK} \times 841.98 \text{ K} (1.679 - 1) = \mathbf{574.56 \text{ kJ/kg}}$$

**6.8 ► DUAL CYCLE**

For same compression ratio, Otto cycle is more efficient but delivers less power than the diesel cycle. Therefore, in dual cycle partly heat is added at constant volume and partly at constant pressure as shown in Figure 6.17.


**FIGURE 6.17**

P-V and T-S Diagrams for Dual Cycle

$$Q_{in} = m C_v (T_3 - T_2) + m C_p (T_4 - T_3); \quad Q_{out} = m C_v (T_5 - T_1)$$

$$\text{Pressure ratio, } r_p = \frac{P_3}{P_2}; \quad \text{Compression ratio, } r_k = \frac{V_1}{V_2}; \quad \text{Cut-off ratio, } r_c = \frac{V_4}{V_3}$$

$$\begin{aligned} \text{Thermal efficiency of Dual cycle, } \eta_{th} &= \frac{Q_{in} - Q_{out}}{Q_{in}} \\ &= \frac{m C_v (T_3 - T_2) + m C_p (T_4 - T_3) - m C_v (T_5 - T_1)}{m C_v (T_3 - T_2) + m C_p (T_4 - T_3)} \\ &= 1 - \frac{(T_5 - T_1)}{(T_3 - T_2) + \gamma (T_4 - T_3)} \end{aligned}$$

$$\text{For isentropic compression process } 1-2, \quad \frac{T_2}{T_1} = \left( \frac{V_1}{V_2} \right)^{\gamma-1} = (r_k)^{\gamma-1}; \quad T_2 = T_1 (r_k)^{\gamma-1}$$

$$\text{For constant volume heat addition process } 2-3, \quad \frac{T_3}{T_2} = \frac{P_3}{P_2}; \quad T_3 = T_2 \frac{P_3}{P_2} = T_3 = T_1 r_p (r_k)^{\gamma-1}$$

$$\text{For constant pressure heat addition process } 3-4, \quad \frac{T_4}{T_3} = \frac{V_4}{V_3} = r_c; \quad T_4 = T_3 r_c = T_1 r_p (r_k)^{\gamma-1} r_c$$

$$\text{For isentropic expansion process } 4-5, \quad T_5 = T_4 \left( \frac{V_4}{V_5} \right)^{\gamma-1} = T_1 r_p (r_k)^{\gamma-1} r_c \left( \frac{V_4}{V_5} \right)^{\gamma-1}$$

$$\text{Now } \frac{V_4}{V_5} = \frac{V_4}{V_1} = \frac{V_4}{V_3} \times \frac{V_3}{V_1} = \frac{V_4}{V_3} \times \frac{V_2}{V_1} = \frac{r_c}{r_k}$$

$$\text{Hence, } T_5 = T_1 r_p (r_k)^{\gamma-1} r_c \left( \frac{r_c}{r_k} \right)^{\gamma-1} = T_1 r_p r_c^\gamma; \quad \text{and } \eta_{th} = 1 - \frac{1}{r_k^{\gamma-1}} \left[ \frac{r_p r_c^\gamma - 1}{(r_p - 1) + \gamma r_p (r_c - 1)} \right]$$



**EXAMPLE 6.6**

An air standard dual cycle has a compression ratio of 18 and compression starts at 0.1 MPa and 300 K. The maximum pressure is 8 MPa. The heat transferred to air at constant pressure is equal to that at constant volume. Determine: (i) temperatures and pressures at the end points of all the processes, (ii) cycle efficiency, and (iii) mean effective pressure.  $C_p = 1.005$  kJ/kg,  $C_v = 0.718$  kJ/kgK,  $\gamma_{air} = 1.4$ .

**SOLUTION**

Given:  $r_k = \frac{V_1}{V_2} = 18$ ,  $P_1 = 0.1$  MPa,  $T_1 = 300$  K,  $P_3 = P_4 = 8$  MPa,  $Q_1 = Q_2$  where  $Q_1$  is heat added at constant volume and  $Q_2$  is heat added at constant pressure

$$P_1 V_1^\gamma = P_2 V_2^\gamma; P_2 = P_1 \left( \frac{V_1}{V_2} \right)^\gamma = 100 \text{ kPa} (18)^{1.4} = 5.72 \text{ MPa.}$$

$$V_2 = \frac{V_1}{18} = \frac{RT_1}{18P_1} = \frac{0.287 \text{ kJ/kgK} \times 300 \text{ K}}{18 \times 100 \text{ kPa}} = 0.0478 \text{ m}^3 = V_3$$

$$V_1 = V_5 = 0.861 \text{ m}^3; T_2 = T_1 \left( \frac{V_1}{V_2} \right)^{\gamma-1} = 300 \text{ K} (18)^{0.4} = 953.3 \text{ K}$$

$$\frac{P_2}{T_2} = \frac{P_3}{T_3} \text{ for constant volume process 2-3.}$$

$$T_3 = \frac{P_3}{P_2} T_2 = \frac{8 \times 10^3 \text{ kPa}}{5720 \text{ kPa}} \times 953.3 \text{ K} = 1333.33 \text{ K}$$

$$Q_1 = C_v (T_3 - T_2) = 0.718 \text{ kJ/kgK} (1333.33 \text{ K} - 953.3 \text{ K}) = 272.86 \text{ kJ/kg}$$

$$= Q_2 = C_p (T_4 - T_3)$$

$$T_4 = \frac{272.86 \text{ kJ/kg}}{1.005 \text{ kJ/kgK}} + 1333.33 \text{ K} = 1604.83 \text{ K}$$

$$\frac{V_4}{T_4} = \frac{V_3}{T_3} \text{ for constant pressure process 3-4; } V_4 = \frac{V_3}{T_3} T_4 = \frac{0.0478 \text{ m}^3}{1333.33 \text{ K}} \times 1604.83 \text{ K}$$

$$= 0.057 \text{ m}^3$$

$$P_4 V_4^\gamma = P_5 V_5^\gamma; P_4 = \left( \frac{0.057 \text{ m}^3}{0.861 \text{ m}^3} \right)^{1.4} \times 8 \times 10^3 \text{ kPa} = 0.178 \text{ MPa}$$

$$T_5 = \frac{P_5}{P_1} T_1 = \frac{0.178 \text{ MPa}}{0.1 \text{ MPa}} \times 300 \text{ K} = 534 \text{ K}$$

Hence,

$$\left. \begin{aligned} P_1 &= 0.1 \text{ MPa}, T_1 = 300 \text{ K}, V_1 = 953.3 \text{ K} \\ P_2 &= 5.72 \text{ MPa}, T_2 = 953.3 \text{ K}, V_2 = 0.0478 \text{ m}^3 \\ P_3 &= 8 \text{ MPa}, T_3 = 1333.33 \text{ K}, V_3 = 0.0478 \text{ m}^3 \\ P_4 &= 8 \text{ MPa}, T_4 = 1604.83 \text{ K}, V_4 = 0.057 \text{ m}^3 \\ P_5 &= 0.17 \text{ MPa}, T_5 = 534 \text{ K}, V_5 = 0.861 \text{ m}^3 \end{aligned} \right\}$$

$$Q_{\text{out}} = C_v(T_5 - T_1) = 0.718 \text{ kJ/kgK}(534 \text{ K} - 300 \text{ K}) = 168.012 \text{ kJ/kg}$$

$$Q_1 = Q_2 = C_v(T_3 - T_2) = 0.718 \text{ kJ/kgK}(1333.33 \text{ K} - 953.3 \text{ K}) = 272.86$$

$$W_{\text{net}} = Q_1 + Q_2 - Q_{\text{out}} = 272.86 \text{ kJ/kg} + 272.86 \text{ kJ/kg} - 168.012 \text{ kJ/kg} \\ = 377.708 \text{ kJ/kg}$$

$$\eta_{\text{th}} = \frac{W_{\text{net}}}{Q_1 + Q_2} = \frac{377.708 \text{ kJ/kg}}{545.72 \text{ kJ/kg}} = 0.6921 = 69.21\%$$

$$P_m = \frac{W_{\text{net}}}{V_1 - V_2} = \frac{377.708 \text{ kJ/kg}}{0.861 \text{ m}^3 - 0.047 \text{ m}^3} = 464.01 \text{ kN/m}^2$$

## 6.9 ► ENGINE PERFORMANCE PARAMETERS

There are several parameters to indicate the performance of an I.C. engine, for example, indicated thermal efficiency ( $\eta_{\text{th}}$ ), brake thermal efficiency ( $\eta_{\text{bth}}$ ), mechanical efficiency ( $\eta_{\text{mech}}$ ), volumetric efficiency ( $\eta_v$ ), relative efficiency of efficiency ratio ( $\eta_{\text{rel}}$ ), mean effective pressure ( $P_m$ ), mean piston speed ( $S_p$ ), specific power output ( $P_s$ ), specific fuel consumption (SFC), and air-fuel ratio (A/F).

**Indicated Thermal Efficiency:** It is the ratio of energy in the indicated diagram ( $I_p$ ) to the input fuel energy.

$$\eta_{\text{ith}} = \frac{i_p \text{ [kJ/s]}}{\text{mass of fuel [kg/s]} \times \text{calorific value of the fuel [kJ/kg]}}$$

**Brake Thermal Efficiency:** It is the ratio of energy in brake power ( $B_p$ ) to the input fuel energy. Brake power is obtained by subtraction of friction losses from indicated power.

$$\eta_{\text{bth}} = \frac{b_p \text{ [kJ/s]}}{\text{mass of fuel [kg/s]} \times \text{calorific value of the fuel [kJ/kg]}}$$

**Mechanical Efficiency:** It is the ratio of the brake power to the indicated power.

$$\eta_{mech} = \frac{b_p}{i_p} = \frac{b_p}{b_p + f_p}; \text{ where } f_p \text{ is a friction power.}$$

**Volumetric Efficiency:** It is the ratio of the volume of air inducted at ambient conditions to the swept volume of the engine.

$$\eta_v = \frac{\text{Volume of charge aspirated per stroke at ambient conditions}}{\text{Stroke volume}}$$

**Relative Efficiency or Efficiency Ratio:** It is the ratio of the thermal efficiency of the actual cycle and the ideal cycle.

$$\eta_{rel} = \frac{\text{Actual thermal efficiency}}{\text{Air standard efficiency}}$$

**Mean Effective Pressure:** It is the average pressure inside the cylinder of an I.C. engine on the measured power output. For any particular engine operating at given speed and power output, there will be a specific indicated mean effective pressure and corresponding brake mean effective pressure. They can be expressed as:

$$P_{im} = \frac{60,000 \times i_p}{lAnk} \quad \text{and} \quad p_{bm} = \frac{60,000 \times b_p}{lAnk}$$

Where  $P_{im}$  = indicated mean effective pressure (N/m<sup>2</sup>)

$p_{bm}$  = brake mean effective pressure (N/m<sup>2</sup>)

$l$  = stroke length (m)

$A$  = Cross-sectional area of piston (m<sup>2</sup>)

$N$  = speed in revolution per minute

$N$  = number of power strikes (N/2 for four-stroke engine and N for two-stroke engine)

$k$  = Number of cylinders

**Mean Piston Speed:** It is defined as— $S_p = 2lN$ , where  $l$  is stroke length in m and  $N$  is the rotational speed of the crankshaft in rpm.

**Specific Power Output:** It is defined as the power output per unit piston area.

$$P_s = \frac{b_p}{A}, \text{ where } b_p \text{ is brake power in kW and } A \text{ is piston area in m}^2.$$

**Specific Fuel Consumption:** It is inversely proportional to thermal efficiency. It is the ratio of fuel consumption per unit time and the power.

**Air-fuel Ratio:** This is the ratio of the mass of air and fuel.

**EXAMPLE 6.7**

The following data were noted for a 4-cylinder, 4-stroke engine:

Diameter = 101 mm, stroke = 114 mm, speed = 1600 rpm, fuel consumption = 0.204 kg/min, heating value of fuel = 41,800 kJ/kg. Difference in either side of the brake pulley = 378 N, Brake circumference = 3.35 m. Assume mechanical efficiency = 83%. Calculate: (i) brake thermal efficiency, (ii) indicated thermal efficiency, (iii) mean effective pressure of cylinder, and (iv) fuel consumption per brake power.

**SOLUTION**

Brake power ( $b_p$ ) =  $\frac{2\pi NT}{60,000} = \frac{2\pi NRW}{60,000}$ ; where N is speed in rotation per minute,

T is braking torque, R is radius, W is braking load.

$$= \frac{3.35\text{ m} \times 1600\text{ rpm} \times 378\text{ N}}{60,000} = 33.77\text{ kW};$$

Brake thermal efficiency ( $\eta_b$ ) =  $\frac{b_p \times 60}{w_f \times H.V.}$ ; where  $w_f$  is fuel consumption in kg/min.

and H.V is heating value of fuel

$$= \frac{33.77\text{ kW} \times 60}{0.204\text{ kg/min} \times 41800\text{ kJ/kg}} = \mathbf{23.8\%}$$

Indicated thermal efficiency ( $\eta_i$ ) =  $\frac{\eta_b}{\eta_{mech}} = \frac{0.237}{0.83} \times 100 = \mathbf{28.5\%}$

Indicated power ( $i_p$ ) =  $\frac{2P_i l A N}{60,000}$ ; where  $P_i$  is indicated mean effective pressure,

l is stroke length, A is internal cross-sectional area of cylinder.

$$\begin{aligned} \text{m.e.p., } P_i &= \frac{60,000 \times b_p}{2lAN \eta_{mech}} = \frac{60,000 \times 33.77\text{ kW}}{2 \times 0.114\text{ m} \times \frac{\pi(0.101\text{ m})^2}{4} \times 1600\text{ rpm} \times 0.83} \\ &= \mathbf{835.75\text{ kPa}} \end{aligned}$$

Brake specific fuel consumption (bsfc) =  $\frac{w_f \times 60}{b_p} = \frac{0.204\text{ kg/min} \times 60\text{ sec}}{33.77\text{ kW}}$   
 $= \mathbf{0.36\text{ kg/bkWh.}}$

## **6.10 ► EMISSION CONTROL**

Emission is the waste gas or flue gas produced by the vehicles or the industry. It produces environmental pollution and results in harmful effect for the human body. Nowadays, pollution is a major issue with the industrial growth. The Government makes an effort to increase awareness among the people about the clean environment and emission control.

### **6.10.1 Types of Emissions**

The major constituents of the air pollutants in the emission are discussed here under.

**Hydrocarbons:** Vehicle produces unburned or partially burned hydrocarbons. Hydrocarbons are toxins that may cause asthma, liver disease, lung disease, and cancer. Regulations governing hydrocarbons vary according to the type of vehicles/engines and jurisdiction; in some cases, non-methane hydrocarbons are regulated while in other cases total hydrocarbons are regulated. Methane is not directly toxic but is more difficult to break down in catalytic converters and also it is a greenhouse gas. Thus, elimination of methane from emission is very important.

**Carbon Monoxide:** It is produced due to incomplete combustion of a fuel. Carbon monoxide reduces the blood's ability to carry oxygen and its overexposure may result in a fatality. It is a killer in high concentrations.

**Nitrogen Oxide (NO<sub>x</sub>):** Nitrogen oxide is produced inside the engine cylinder at high-temperature and pressure by reacting with oxygen. It may result in smog and acid rain. NO<sub>x</sub> is the sum of NO and NO<sub>2</sub>, NO<sub>2</sub> is highly reactive.

**Particulate Matter:** It is a soot or smoke particle of micro sizes. It causes respiratory disease, cancer, and other health problems.

**Volatile Organic Compounds:** They are organic compounds having a boiling point less than 250°C. Some of the volatile organic compounds as the constituents of emission are chlorofluorocarbons (CFCs) and formaldehyde. They are dangerous to health.

**Sulfur Oxide (SO<sub>x</sub>):** It is emitted from motor vehicles burning fuel containing sulfur. Therefore, the reduced amount of sulfur for petroleum products is very important

### **6.10.2 Emission Control Techniques**

#### ***Positive Crankcase Ventilation (PCV) Valve***

The purpose of the positive crankcase ventilation (PCV) system is to take the vapors produced in the crankcase during the normal combustion process, and redirecting them

into the air/fuel intake system to be burned during combustion. These vapors dilute the air/fuel mixture so they have to be carefully controlled and metered in order to not affect the performance of the engine. This is the job of the positive crankcase ventilation (PCV) valve.

At idle, when the air/fuel mixture is very critical, just little vapors are allowed into the intake system. At high speed when the mixture is less critical and the pressures in the engine are greater, more of the vapors are allowed into the intake system. When the valve or the system is clogged, vapors will back up into the air filter housing or at worst; the excess pressure will push past seals and create engine oil leaks. If the wrong valve is used or the system has air leaks, the engine will idle rough, or at worst, engine oil will be sucked out of the engine.

### *Exhaust Gas Recirculation Valve (EGR) Valve*

The purpose of the exhaust gas recirculation valve (EGR) valve is to meter a small amount of exhaust gas into the intake system; this dilutes the air/fuel mixture so as to lower the combustion chamber temperature. Excessive combustion chamber temperature creates oxides of nitrogen, which is a major pollutant. While the EGR valve is the most effective method for controlling oxides of nitrogen, in its varying design it adversely affects engine performance. The engine was not designed to run on exhaust gas. For this reason, the amount of exhaust entering the intake system has to be carefully monitored and controlled. This is accomplished through a series of electrical and vacuum switches and the vehicle computer. Since EGR action reduces performance by diluting the air/fuel mixture, the system does not allow EGR action when the engine is cold or when the engine needs full power.

### *Catalytic Converter*

One of the ways to control the automotive emission is to provide an additional area for oxidation or combustion to occur. This additional area is called a catalytic converter. The catalytic converter looks like a muffler. It is located in the exhaust system ahead of the muffler. A honeycomb made of platinum or palladium is arranged inside the converter. The platinum or palladiums are used as a catalyst (a catalyst is a substance used to speed up a chemical process). As hydrocarbons or carbon monoxide in the exhaust passes over the catalyst, it is chemically oxidized or converted to carbon dioxide and water. The leaded fuel puts a coating on the platinum or palladium and renders the converter ineffective. This is the reason that the use of unleaded petrol is suggested.

### *Air Injection*

Since no internal combustion engine provides the complete combustion, there is always some unburned fuel in the exhaust. This increases hydrocarbon emissions. To eliminate this

source of emissions an air injection system has been created. Combustion requires fuel, oxygen, and heat. Without any one of the three, combustion cannot occur. Inside the exhaust manifold, there is sufficient heat to support combustion if some oxygen is induced than any unburned fuel will ignite. This combustion will not produce any power, but it will reduce excessive hydrocarbon emissions. Unlike in the combustion chamber, this combustion is uncontrolled, so if the fuel content of the exhaust is excessive, explosions that sound like popping will occur.

## **6.11 ► SOME RECENT DEVELOPMENTS IN AUTOMOTIVE TECHNOLOGY**

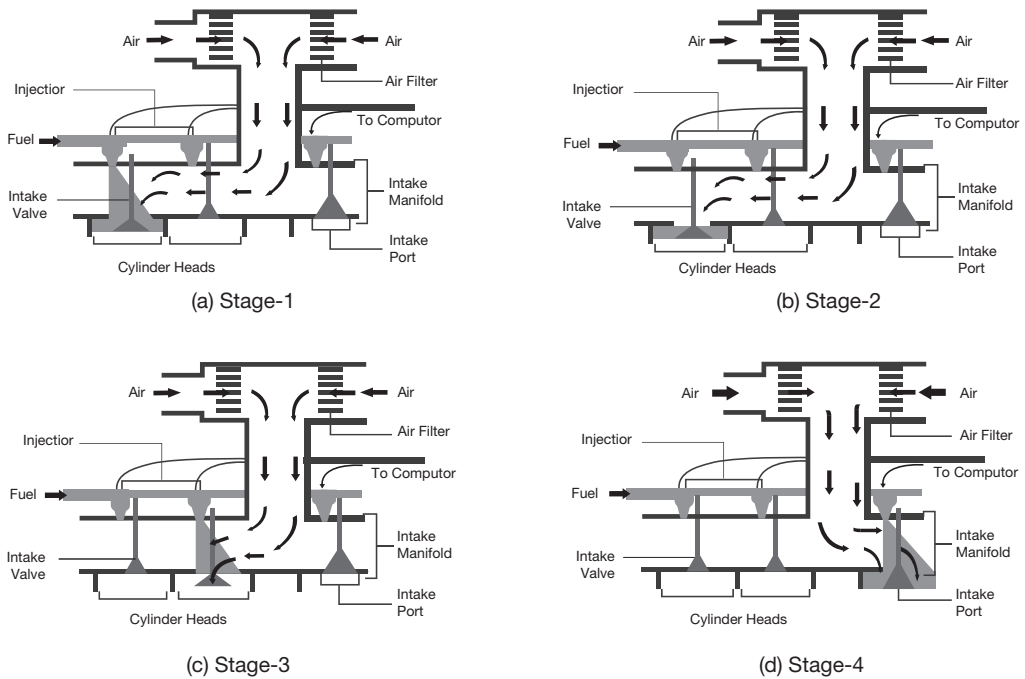
In the recent years, some great development in the automotive technology has been observed. The research and development in the automotive area has been the area of interest of the researchers as well as practitioners. Some of the most fundamental principles of the I.C. Engines have been changed. For example, the use of carburetor in petrol engine has been replaced by the multi-point fuel injection system (MPFI) and simple injection system in the diesel engine has been replaced by the common rail direct injection system (CRDI). In this section, MPFI and CRDI have been introduced.

### **6.11.1 Multi-point Fuel Injection**

Before the invention of the MPFI engine, the carburetor was used to mix the petrol and air in the proper ratio. The mixed air fuel is sent to the combustion chamber for the combustion and a mechanical power is produced from the heat energy of the fuel. The main problem with the carburetor is that the mixing of fuel and air is not in the proper ratio, which results in incomplete combustion and more pollution. To minimize the emission in the carburetor engine, MPFI engine is developed.

In a petrol engine, the power is produced by burning the petrol inside the cylinder. At first, the petrol is allowed to mix with air. It is then ignited in a cylinder called as the **combustion chamber**. The MPFI is an advanced version of carburetor engine. The MPFI engine consists of a fuel injector for each cylinder. A small computer/microcontroller is used to control each and every fuel injector individually. This microcontroller monitors each **fuel injectors** and controls the amount of fuel to be injected into the cylinder so that the fuel wastage can be minimized. Since there is a controlled fuel usage, the engine is known for its fuel efficient engine.

The working of MPFI engine is shown in Figure 6.18 in four stages. The amount of fuel to be injected into the combustion chamber is decided by analyzing the inputs given to the computerized system of the MPFI engine. In modern MPFI engines, a memory unit is additionally installed. This makes the MPFI engine capable of storing the user settings so that it can operate easily. The driving habits of a driver can also be detected by this



**FIGURE 6.18**

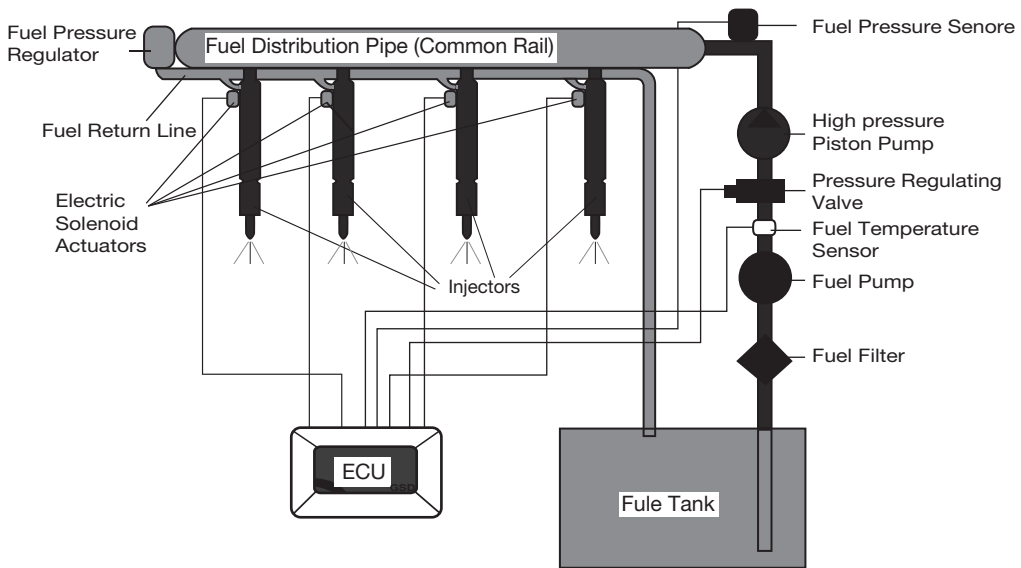
Multi-point Fuel Injection Engine

system so that the **MPFI system** itself can change the predefined settings, which suits the user.

Even though the working of MPFI engine is very much similar to the **carburetor** engine, each cylinder is treated individually. An input is fed to the computerized system in order to calculate the amount of air and fuel to be mixed and send to the combustion chamber. Several stages of calculations are to be made in order to decide the right amount of fuel to be mixed. After this calculation, the proper fuel is delivered at the proper instance. Many sensors are used in the MPFI engine. At the time when the inputs are given to the car's computer, it begins to read the sensors. The information which can be received from the sensors are given below:

- ▶ The engine temperature of the vehicle.
- ▶ The speed at which the engine is running.
- ▶ The engine load.
- ▶ The position of the accelerator.
- ▶ The cylinder's air-fuel pressure.
- ▶ The rate of exhaust.



**FIGURE 6.19**

CRDI Line Diagram

### 6.11.2 Common Rail Direct Injection (CRDI)

CRDI is an advanced fuel injection technology, which is most commonly referred to diesel engines. This is very similar to the technology used in petrol engines and the same is differentiated by classifying it as gasoline direct injection (GDI) or fuel stratified injection (FSI). Although both these technologies have a similarity in design as they consist of a common “fuel-rail” to supply fuel to the injectors, they considerably differ from each other in pressures and the type of fuel used.

In the CRDI system, commencement of combustion takes place directly into the main combustion chamber located in a cavity on the top of the piston crown. Today, CRDI technology is being widely used to overcome some of the deficiencies of conventional diesel engines, which were sluggish, noisy, and poor in performance when implemented especially in passenger vehicles. The line diagram of CRDI technique is shown in Figure 6.19.

The CRDI technology works in with the engine control unit (ECU), which instruction from various sensors to find the exact quantity of fuel and timing of injection. The conventional injectors are replaced with solenoid operated injectors. The injectors are opened with an ECU signal depending upon the variables such as engine speed, load, engine temperature, etc.

In a Common Rail system, a common fuel-rail or a fuel distribution pipe is used to maintain optimum residual fuel pressure and acts as a shared fuel reservoir for all the injectors. The fuel is constantly supplied at the required pressure for injection.

The pressure generation takes place in the high-pressure pump. The pump compresses the fuel at the pressures at about 1,500 bar and above. It then supplies the fuel via a high-pressure pipe to the inlet of the rail. From there, the fuel is distributed to the individual injectors, which inject it into the cylinder's combustion chamber.

Most modern diesel engines use this system with Unit-Injector system combined with a Turbocharger to achieve increased power output and meet stringent emission norms. This helps to improve engine power, throttle response, fuel efficiency, and control emissions.

### 6.11.3 Hybrid Engine

In a traditional hybrid vehicle, we have a complete electric or the gasoline/diesel cars. In an electric car, the electric motor provides all of the power to the wheel and the batteries supply electricity to the motor. In a gasoline engine powering a generator, the engine of the very small power of 10 to 20 horsepower is designed to run at just one speed to provide maximum efficiency. The purpose of this small efficient engine is to provide enough power for the car at its cruising speed. During times of acceleration, the batteries provide the extra power necessary. When the car is decelerating or standing still the batteries recharge. This sort of hybrid car is essentially an electric car with a built-in recharger for longer range. The advantage is that the small, efficient gasoline engine gets great mileage.

The only problem with a traditional hybrid car is the weight. The car has to carry the weight of the electric motor, the generator, the gasoline engine, and the batteries.

Most hybrids use the following advanced technologies:

- ▶ **Regenerative Braking System:** Regenerative braking recaptures energy normally lost during braking. It uses the forward motion of the wheels to turn the motor in reverse. This generates electricity and helps to slow down the vehicle.
- ▶ **Electric Motor Drive/Assist:** The electric motor provides power to assist the engine in accelerating, passing, or hill climbing. This allows a smaller, more-efficient engine to be used. In some hybrids, the electric motor alone propels the vehicle at low speeds, where gasoline engines are least efficient.
- ▶ **Automatic Start/Stop:** Automatically shuts off the engine when the vehicle comes to a stop and restarts it when the accelerator is pressed. This reduces wasted energy from idling.

## RECAP ZONE .....



### Points to Remember

- The heat engine, in which the combustion takes place inside the cylinder or the product of combustion (flue gas) directly goes to the cylinder and the heat energy of the flue gas is converted into mechanical energy, is known as “**Internal Combustion Engine** (I.C. Engine)”.
- In four strokes of a spark ignition engine, the cycle of operations is completed in 4-strokes of the piston or two revolutions of the crankshaft.
- The **compression ratio** of S.I. Engine varies from 6 to 10 whereas in C.I. Engines it ranges from 16 to 20.
- In a four-stroke S.I. engine, there is one power stroke in two revolutions of the crankshaft and two strokes, viz., suction and exhausts are non-productive.
- In two strokes of a spark ignition engine, the cycle of operations is completed in 2-strokes of the piston or one revolution of the crankshaft.
- S.I. Engine is based on Otto cycle or constant volume heat addition and rejection cycle.
- C.I. Engine is based on a diesel cycle or constant pressure heat addition and constant volume heat rejection cycle.
- In **Otto cycle**, heat added and rejected at constant volume.
- In **Diesel cycle**, heat is added at constant pressure and heat rejected at constant volume.
- **Valve timing diagram** is a graphical representation of valves opening and closing time with ignition time in terms of angle of crank revolution.
- For same compression ratio, Otto cycle is more efficient, but delivers less power than the diesel cycle. Therefore, in dual cycle partly heat is added at constant volume and partly at constant pressure.
- **Indicated thermal efficiency** is the ratio of energy in the indicated diagram ( $I_p$ ) to the input fuel energy.
- **Brake thermal efficiency** is the ratio of energy in brake power ( $B_p$ ) to the input fuel energy. Brake power is obtained by subtraction of friction losses from indicated power.
- **Mechanical efficiency** is the ratio of the brake power to the indicated power.
- **Volumetric efficiency** is the ratio of the volume of air inducted at ambient conditions to the swept volume of the engine.
- **Relative efficiency** or **efficiency ratio** is the ratio of the thermal efficiency of the actual cycle and the ideal cycle.
- **Mean effective pressure** is the average pressure inside the cylinder of an I.C. engine on the measured power output.

## Important Formulae

1. Thermal efficiency of Otto cycle:  $\eta_{th} = 1 - (r_k)^{1-\gamma} = 1 - \frac{1}{(r_k)^{\gamma-1}}$
2. Thermal efficiency of diesel cycle:  $\eta_{th} = 1 - \frac{1}{(r_k)^{\gamma-1}} \left[ \frac{(r_c)^\gamma - 1}{\gamma(r_c - 1)} \right]$
3. Thermal efficiency of dual cycle:  $\eta_{th} = 1 - \frac{1}{r_k^{\gamma-1}} \left[ \frac{r_p r_c^\gamma - 1}{(r_p - 1) + \gamma r_p (r_c - 1)} \right]$
4. Indicated thermal efficiency of an I.C. engine:  

$$\eta_{ith} = \frac{i_p \text{ [kJ/s]}}{\text{mass of fuel [kg/s]} \times \text{calorific value of the fuel [kJ/kg]}}$$
5. Brake thermal efficiency of an I.C. engine:  

$$\eta_{bth} = \frac{b_p \text{ [kJ/s]}}{\text{mass of fuel [kg/s]} \times \text{calorific value of the fuel [kJ/kg]}}$$
6. Mechanical efficiency:  

$$\eta_{mech} = \frac{b_p}{i_p} = \frac{b_p}{b_p + f_p}; \text{ where } f_p \text{ is a friction power.}$$
7. Volumetric efficiency:  

$$\eta_v = \frac{\text{Volume of charge aspirated per stroke at ambient conditions}}{\text{Stroke volume}}$$
8. Relative efficiency or efficiency ratio:  $\eta_{rel} = \frac{\text{Actual thermal efficiency}}{\text{Air standard efficiency}}$
9. Mean effective pressure:  $P_{im} = \frac{60,000 \times i_p}{lAnk}$  and  $p_{bm} = \frac{60,000 \times b_p}{lAnk}$

## REVIEW ZONE .....



### Multiple-choice Questions

1. In I.C. engines, power developed inside the cylinder is known as:
  - (a) Brake horse power
  - (b) Indicated horse power
  - (c) Pumping power
  - (d) None of the above
2. The power spent in suction and exhaust strokes are known as:
  - (a) Brake horse power
  - (b) Indicated horse power
  - (c) Net indicated horse power
  - (d) None of the above
3. The difference of total power produced and pumping power is known as:
  - (a) Brake horse power
  - (b) Indicated horse power
  - (c) Net indicated horse power
  - (d) None of the above

4. The power available at the shaft of an I.C. engine is known as:
  - (a) Brake horse power
  - (b) Indicated horse power
  - (c) Net indicated horse power
  - (d) None of the above
5. In a four-stroke engine, number of revolutions of the crankshaft for completion of working cycle is:
  - (a) One
  - (b) Two
  - (c) Three
  - (d) Four
6. In a two-stroke engine, number of revolutions of the crankshaft for completion of working cycle is:
  - (a) One
  - (b) Two
  - (c) Three
  - (d) Four
7. Theoretically, four-stroke engine should develop power as compared to two-stroke engine is:
  - (a) Half
  - (b) Same
  - (c) Double
  - (d) Four times
8. At the same speed, the number of power strokes given by a two-stroke engine as compared to a four-stroke engine is:
  - (a) Half
  - (b) Same
  - (c) Double
  - (d) Four times
9. Thermal efficiency of two-stroke engine in comparison to four-stroke engine is:
  - (a) More
  - (b) Same
  - (c) Less
  - (d) None of the above
10. Mechanical efficiency of two-stroke engine in comparison to four-stroke engine is:
  - (a) More
  - (b) Same
  - (c) Less
  - (d) None of the above
11. In a petrol engine, charge is ignited with:
  - (a) Spark plug
  - (b) Compression
  - (b) Intake valve closed after bottom dead center
  - (c) Exhaust valve closes after top dead center
  - (c) Both
  - (d) Exhaust valve closes after bottom dead center
  - (d) None of the above
12. In four-stroke petrol engine:
  - (a) Intake valve closes after top dead center
13. Compression ratio in petrol engine ranges from:
  - (a) 6 to 10
  - (b) 10 to 15
  - (c) 15 to 25
  - (d) 25 to 40
14. Compression ratio in diesel engine ranges from:
  - (a) 6 to 10
  - (b) 10 to 15
  - (c) 14 to 22
  - (d) 25 to 40
15. If compression ratio in petrol engines kept higher than that is in diesel engines, then:
  - (a) Pre-ignition of fuel will occur
  - (b) Ignition of fuel will be delayed
  - (c) Detonation will occur
  - (d) None of the above
16. In C.I. Engines, the combustion is:
  - (a) Homogeneous
  - (b) Heterogeneous
  - (c) Both
  - (d) None of the above
17. Which of the following is not related to C.I. engine:
  - (a) Fuel pump
  - (b) Fuel injector:
  - (c) Carburetor
  - (d) Flywheel
18. Indicator on an engine is used to determine:
  - (a) B.H.P
  - (b) Speed
  - (c) Temperature
  - (d) I.H.P and M.E.P
19. Morse test is conducted on:
  - (a) Vertical engines
  - (b) Horizontal engines
  - (c) Single cylinder engines
  - (d) Multi cylinder engines
20. The m.e.p. of a diesel engine with fixed compression ration can be improved by:
  - (a) Increasing cut-off ratio
  - (b) Increasing back pressure
  - (c) Increasing operating pressure
  - (d) Reducing charge density

## Fill in the Blanks

21. An engine is said to be square if cylinder bores equal to \_\_\_\_\_.
22. The period during both inlet and exhaust valve remain open is known as \_\_\_\_\_.
23. A two-stroke engine employs \_\_\_\_\_ cut in the wall of cylinder instead of \_\_\_\_\_.
24. In four-stroke petrol engine, size of intake valve is \_\_\_\_\_ than that of exhaust valve.
25. Carburetion is the process of \_\_\_\_\_ and \_\_\_\_\_.

## Answers

- |                   |             |                                  |                   |         |         |
|-------------------|-------------|----------------------------------|-------------------|---------|---------|
| 1. (b)            | 2. (c)      | 3. (c)                           | 4. (a)            | 5. (b)  | 6. (a)  |
| 7. (a)            | 8. (c)      | 9. (c)                           | 10. (a)           | 11. (a) | 12. (b) |
| 13. (a)           | 14. (c)     | 15. (a)                          | 16. (b)           | 17. (c) | 18. (d) |
| 19. (d)           | 20. (a)     | 21. stroke length                | 22. Valve overlap |         |         |
| 23. ports, valves | 24. Smaller | 25. Mixing, vaporization of fuel |                   |         |         |

## Theory Questions

1. Define internal combustion engine and explain how it is different from external combustion engines?
2. What are the different bases for classification of an internal combustion engine? Explain with a neat sketch of various types of the engines.
3. Differentiate S.I. engine and C.I. engine.
4. Explain the fundamental differences between Otto cycle and Diesel cycle mentioning the advantages over each other.
5. What are the fundamental differences between two-stroke and four-stroke engines?
6. Explain the structure and working of four-stroke petrol engine with a neat sketch.
- \*7. Explain the structure and working of four-stroke diesel engine with a neat sketch.
8. What is scavenging? Explain the structure and working of two-stroke petrol engine.
9. What is supercharging? Explain the structure and working of two-stroke diesel engine.
10. Explain the valve timing diagram of four-stroke petrol and diesel engines.
11. Derive an expression for the efficiency of Otto cycle.
12. Explain the working of the dual cycle with the help of  $P-V$  and  $T-S$  diagrams. Derive an expression for air standard efficiency of the dual cycle in terms of compression ratio, pressure ratio, cut-off ratio, and adiabatic index.
13. Write down working of two-stroke petrol engine with neat sketch.
- \*14. Draw the diesel cycle on  $P-V$  and  $T-S$  coordinates and explain its functioning.
- \*15. How are I.C. engines classified? Draw  $P-V$  diagrams of Otto and diesel engine cycles.
- \*16. Differentiate between C.I and S.I. engine.
- \*17. Explain with the neat sketch, working of the two-stroke petrol engine.
- \*18. Derive an equation for air standard efficiency of Otto cycle.
- \*19. Derive the equation for air standard efficiency of Diesel cycle.
- \*20. Differentiate between Petrol engine and diesel engine.
- \*21. Explain the working of four-stroke petrol engine with neat sketch.
- \*22. Explain the working of four-stroke petrol engine with neat sketch and  $P-V$  diagram.
- \*23. With the neat sketch, explain the principle of MPFI?
- \*24. With the neat sketch, explain the principle of CRDI?
- \*25. Give advantages of two-stroke engine over four-stroke engine.
- \*26. Draw a schematic diagram of I.C. engines and name the parts.
- \*27. Define—Thermal efficiency and mechanical efficiency of I.C. engine.

\* indicates that similar questions have appeared in various university examinations.

## Numerical Problems

- In an air standard Otto cycle, the pressure and temperature at the start of compression stroke are 1 bar and 30°C, respectively. The temperature at the end of compression is 270°C and heat addition at constant volume is 2,000 kJ. Calculate: (i) thermal efficiency, (ii) net work per kg of air, (iii) maximum temperature in the cycle, and (iv) mean effective pressure.
- In an Otto cycle, air at 1 bar and 300K is compressed isentropically until the pressure rises to 16 bar. The heat is added at constant volume until the pressure rises to 30 bar. Calculate the air standard efficiency and mean effective pressure of the cycle. Take  $C_v = 0.717 \text{ kJ/kgK}$ ;  $R = 8.314 \text{ kJ/kg mole}$ .
- In an air standard diesel cycle, the temperatures at the start and at the end of compression stroke are 298 K and 800 K, respectively. The energy added at constant pressure is 800 kJ/kg of air. Determine: (i) compression ratio, (ii) cut-off ratio, (iii) maximum cycle temperature, and (iv) thermal efficiency. Assume  $C_p = 1.005 \text{ kJ/kg}$ .
- A diesel engine has a compression ratio of 16 and cut-off take place at 7% of the stroke. Find the air standard efficiency.
- In an ideal dual cycle, the compression ratio is 12 and maximum pressure is limited to 80 bar. If the heat supplied is 2,000 kJ/kg, find the temperature and pressure at all cardinal points and the cycle efficiency. The pressure and temperature of air at the commencement of compression are 1 bar and 90°C, respectively. Assume  $C_p = 1.005 \text{ kJ/kgK}$  and  $C_v = 0.717 \text{ kJ/kgK}$  of air.
- A dual cycle operates with a compression ratio  $r_k = 10$  and cut-off ratio 1.6. The maximum pressure is given by  $P_{\max} = 60P_1$ , where  $P_1$  is the pressure before compression. Assume indices of compression and expansion as 1.4, find the mean effective pressure in the terms of  $P_1$ .
- The following readings were taken during the test of four-stroke single cylinder petrol engine:  
Load on brake drum = 50 kg;  
Diameter of brake drum = 1,250 mm  
Spring balance reading = 7 kg;  
Engine speed = 450 rpm  
Fuel consumption = 4 kg/hr;  
Calorific value of fuel = 43,000 kJ/kg  
Calculate: (i) indicated thermal efficiency, and (ii) brake thermal efficiency. Assume mechanical efficiency as 70%.
- The following results refer to a test on C.I. Engine:  
Indicated power = 37 kW;  
Frictional power = 6 kW;  
Brake specific fuel consumption = 0.28 kg/KWh;  
Calorific value of fuel = 44,300 kJ/kg  
Calculate: (i) mechanical efficiency, (ii) brake thermal efficiency, and (iii) indicated thermal efficiency.
- During testing of single cylinder two-stroke petrol engine, following data were obtained—brake torque = 640 Nm; cylinder diameter = 21 cm, speed = 250 rpm; stroke = 28 cm; m.e.p. = 5.6 bar; oil consumption = 8.16 kg/hr; C.V. = 42,705 kJ/kg. Determine: (i) mechanical efficiency, (ii) indicated thermal efficiency, and (iii) Brake specific fuel consumption.
- Following readings were taken during test of single cylinder four-stroke engine:  
Cylinder diameter = 250 mm; stroke length = 400 mm; m.e.p. = 6.5 bar; Engine speed = 250 rpm; net load on brake = 1,080 N; effective diameter of brake = 1.5 m; fuel used per hour = 10 kg; calorific value of fuel = 44,300 kJ/kg.  
Calculate: (i) indicated horse power, (ii) brake horse power, (iii) mechanical efficiency, and (iv) indicated thermal efficiency.
- In an ideal diesel cycle, the temperatures at the beginning and at the end of compression are 57°C and 603°C, respectively. The temperatures at the beginning and at the end of expansion are 1959°C and 870°C, respectively. Determine the ideal efficiency of the cycle if the pressure at the beginning is 1 bar. Calculate maximum pressure in the cycle.
- In an air standard Otto cycle, the compression ratio is 10 and begins at 37.8°C, 1 bar and maximum temperature of the cycle is 1060°C. Determine: (i) heat supplied per kg of air, (ii) work

- done per kg of air, (iii) maximum pressure of the cycle, and (iv) the thermal efficiency.
13. In an air standard diesel cycle, the compression ratio is 15 and pressure and temperature of the air at the beginning of the compression are 1 bar and 288 K. The peak temperature in the cycle is 2,700 K. Calculate: (i) heat supplied, (ii) work done, (iii) cycle efficiency, (iv) peak pressure of the cycle, (v) cut-off ratio, and (vi) m.e.p.
  14. A gas engine working on four-stroke cycle has a cylinder of 250 mm diameter, length of stroke 450 mm and is running at 180 rpm. Its mechanical efficiency is 80%; mean effective pressure is 0.65 MPa, Find: (i) indicated power, (ii) brake power, and (iii) friction power.
  15. A four-stroke single cylinder petrol engine has a bore of 150 mm and stroke of 250 mm. At 500 rpm and full load, the net load on friction brake is 435 N and torque arm is 0.45 m. The indicator diagram gives a net area of 580 mm<sup>2</sup> and a length of 70 mm with a spring rating of 0.85 bar/mm<sup>2</sup>. Determine: (i) indicated power, (ii) brake power, and (iii) mechanical efficiency.
  16. Following observations were made during a trial on four-stroke diesel engine. Cylinder diameter = 250 mm, stroke = 400 mm, speed = 250 rpm brake load = 70 kg, brake drum diameter = 2m. m.e.p. = 6 bar, diesel oil consumption = 0.1 m<sup>3</sup>/min., specific gravity of fuel = 0.78, C.V. = 43,900 kJ/kg. Determine: (i) IP, (ii) BP, (iii) FP, (iv) Mechanical efficiency, (v) brake thermal efficiency, and (vi) indicated thermal efficiency.
  17. Following data were collected from a four-stroke single cylinder I.C. engine at full load. Bore = 200 mm, stroke = 280 mm, speed = 300 rpm, m.e.p. = 5.6 bar, torque = 250 Nm. Oil consumption = 4.2 kg/h, C.V. = 41,000 kJ/kg. Determine: (i) mechanical efficiency, (ii) indicated thermal efficiency, and (iii) brake thermal efficiency.
  - \*18. During testing of single cylinder two-stroke petrol engine following data were obtained. Brake torque = 640 Nm, cylinder diameter 21 cm, speed 350 rpm, stroke length = 28 cm, mean effective pressure = 5.6 bar, oil consumption = 8.16 kg/h, calorific value of the fuel = 42,705 kJ/kg. Determine: (i) mechanical efficiency, (ii) Indicated thermal efficiency, (iii) Brake thermal efficiency, and (iv) brake specific fuel consumption.
  - \*19. In an engine working on Otto cycle, air has a pressure of 1.0 bar and temperature 30°C at the entry. Air is compressed with a compression ratio of 6. The heat is added at constant volume until the temperature rises to 1,500°C. Determine: (i) air standard efficiency, (ii) pressure and temperature at the end of compression, and (iii) heat supplied. Take  $C_v = 0.718 \text{ kJ/kg K}$ ,  $R = 0.287 \text{ kJ/kg K}$ .
  - \*20. In an Otto cycle, the compression ratio is 10. The temperature at the beginning of compression and at the end of heat supply is 300 and 1600 K, respectively. Assume,  $\gamma = 1.4$  and  $C_v = 0.717 \text{ KJ/kgK}$ . Find: (i) Heat supplied, and (ii) Efficiency of the cycle.
  - \*21. The following data refers to a single cylinder 4 strokes petrol engine. Cylinder diameter = 30 cm, piston stroke = 40 cm, engine speed = 1,400 rpm, indicated mean effective pressure = 5 bar, fuel consumption = 17.568 kg/h, calorific value of the fuel is 45,000 kJ/kg; specific gravity of the fuel is 0.8. Determine the indicated thermal efficiency.
  - \*22. In ideal constant volume cycle, the pressure and temperature at the beginning of compression are 97 kPa and 50°C, respectively. The volume ratio is 8. The heat is supplied during the cycle is 930 kJ/kg of working fluid. Calculate: (i) the maximum temperature attained in the cycle, (ii) the thermal efficiency of the cycle, and (iii) work done during the cycle/kg of working fluid.
  - \*23. A four cylinder two-stroke petrol engine with stroke to bore ratio 1.2 develops 35 kW brake power at 2,200 rpm. The mean effective pressure in each cylinder is 9 bar and mechanical efficiency is 78%. Determine: (i) Diameter and stroke of each cylinder, (ii) brake thermal efficiency, and (iii) indicated thermal efficiency. If fuel consumption 8 kg/h having C.V. = 43,000 kJ/kg.
  - \*24. An engine operates on the air standard diesel cycle. The conditions at the start of the compression stroke are 353 K and 100 kPa, while at the

\* indicates that similar questions have appeared in various university examinations.



end of compression stroke the pressure is 4 MPa. The energy absorbed is 700 kJ/kg of air. Calculate: (i) the compression ratio, (ii) the cut-off ratio, (iii) the work done per kg air, and (iv) the thermal efficiency.

- \*25. An air at 15°C and 1 bar is compressed adiabatically to 15 bar by an engine working on Otto cycle. The maximum pressure of the cycle is 40 bar. Calculate air standard efficiency, mean effective pressure. Take  $C_v = 0.718 \text{ kJ/kg K}$  and  $R = 0.287 \text{ kJ/kg K}$ .
- \*26. A four-stroke diesel engine has a piston diameter 250 mm and stroke 400 mm. The mean effective pressure is 4 bar and speed is 500 rpm the diameter of the brake drum is 1,000 mm and the effective brake load is 4,000 N. Find IP, BP, FP.
- \*27. A gas engine working on 4-stroke cycle has a cylinder diameter 300 mm and stroke length of 500 mm is running at 220 rpm. Its mechanical efficiency is 80% when the mean effective pressure is 0.65 MPa. Find (i) indicated power, (ii) brake power, and (iii) friction power.

## Learning Objectives

*By the end of this chapter, the student will be able:*

- To understand the different modes of heat transfer
- To describe the concepts of heat transfer through wall, hollow cylinder, and hollow sphere
- To apply the concept of heat transfer in the different engineering applications

## 7.1 ► INTRODUCTION

This chapter deals with different modes of heat transfer, which are usually classified as conduction, convection, and radiation. From the second law of thermodynamics, we know that the heat flows whenever there is existence of temperature difference or temperature gradient. Heat is a form of energy which is transferred from one body to another body at a lower temperature, by virtue of the temperature difference between the bodies. The concept of heat transfer is widely applicable to different fields of mechanical engineering such as heat exchanger, boiler, radiator, nuclear power plant, refrigeration, and air conditioning, etc. In this chapter, we will learn about the basic concepts of different modes of heat transfer.

### 7.1.1 Conduction

Conduction is the heat transfer from one part of a substance to another part of the same substance, or from one substance to another in Physical contact with it, without appreciable displacement of the molecules forming the substance. On the elementary particle level, the conduction is visualized as the exchange of kinetic energy between the particles in high and

low-temperature regions. Therefore, the conduction is attributed to the elastic collisions of molecules in gases and liquids, to the motion of free electrons in metals, and to the longitudinal oscillation of atoms in solid insulators of electricity. A distinguishing characteristic of conduction is that it takes place within the boundary of a medium, or across the boundary of a medium into another medium in contact with the first, without an appreciable displacement of the matter.

The heat transfer in conduction mode at a macroscopic level and use of a phenomenological law is based on experiments of Biot and formulated by J.B. Fourier in 1882. This law can be illustrated by considering a wall of thickness  $L$ , surface area  $A$  and whose faces are kept at temperatures  $t_1$ , and  $t_2$ , as shown in Figure 7.1.  $t_1$  is greater than  $t_2$ . Under these conditions, heat flows from the face of high-temperature to the face of low-temperature. According to Fourier's law of heat conduction, the rate of heat transfer in the  $x$ -direction through the wall element,  $dx$ , located at  $x$  is proportional to:

- the gradient of temperature in that direction,  $dt/dx$ , and
- the surface area normal to the direction of heat transfer,  $A$

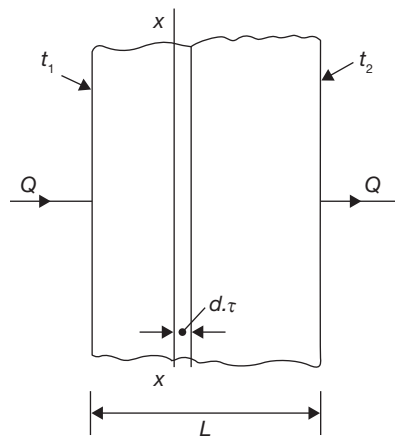
Therefore, the heat transfer rate is given by:

$$Q \propto -A \frac{dt}{dx}$$

or,

$$q = \frac{Q}{A} = -k \frac{dt}{dx}$$

where  $k$  is the constant of proportionality and it is called the "thermal conductivity"; it is a property of the material. The negative sign appearing in Equation is due to the convention that the heat is taken to be positive in the direction of increasing  $x$  and also ensures that heat flows in the direction of decreasing temperature, thus satisfies the second law of thermodynamics. If  $Q$  is in  $W$ ,  $A$  in  $m^2$ , and  $dt/dx$  in  $^{\circ}C/m$ , then the unit of  $k$  is  $W/m^2 \text{ } ^{\circ}C/m$ . This may be written as  $W/m \text{ } ^{\circ}C$ .



**FIGURE 7.1**

Heat Transfer through Wall of Thickness  $L$

**EXAMPLE 7.1**

The inner surface of a plain brick wall is at  $60^{\circ}\text{C}$  and the outer surface is at  $20^{\circ}\text{C}$ . Calculate the rate of heat transfer per  $\text{m}^2$  of the surface area of the wall, which is 260 mm thick. The thermal conductivity of the brick is  $0.55 \text{ W/mK}$ .

**SOLUTION**

Given:  $t_1 = 60^{\circ}\text{C}$ ;  $t_2 = 20^{\circ}\text{C}$ ;  $x = 260 \text{ mm}$ ;  $k = 0.55 \text{ W/mK}$

$$q = \frac{Q}{A} = -k \frac{dt}{dx} = \frac{0.55 \text{ W/mK}}{0.260 \text{ m}} (60^{\circ}\text{C} - 20^{\circ}\text{C}) = 84.6 \text{ W/m}^2$$

**7.1.2 Convection**

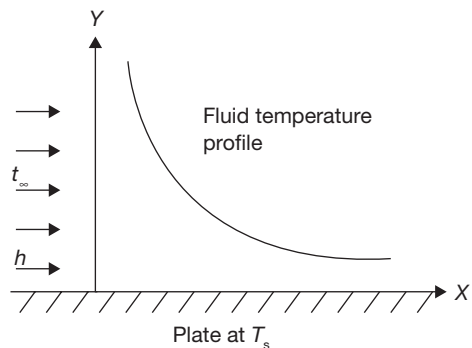
Convection is the term used for heat transfer mechanism which takes place in a fluid because of a combination of conduction due to the molecular interactions and energy transport and, the macroscopic motion of the fluid itself. In the above definition, the motion of the fluid is essential otherwise the heat transfer mechanism becomes a static conduction situation as illustrated in Figure 7.2. When the term of convection is used, usually a solid surface is present next to the fluid. There are also cases of convection where only fluids are present, such as a hot jet entering into a cold reservoir. However, the most industrial applications involve a hot or cold surface transferring heat to the fluid or receiving heat from the fluid.

The convective heat transfer can be explained using Newton's Law of cooling which states that the rate of heat transfer per unit area is directly proportional to the temperature difference between a surface and the fluid and mathematically can be expressed as below:

$$\frac{Q}{A} \propto (t_s - t_{\infty})$$

or, 
$$\frac{Q}{A} = h.(t_s - t_{\infty})$$

or, 
$$Q = h.A.(t_s - t_{\infty})$$

**FIGURE 7.2**

Convective Heat Transfer from Fluid to a Metal Plate

Where  $t_s$  is surface temperature and  $t_\infty$  in  $^\circ\text{C}$ ;  $h$  is the coefficient of proportionality, called the heat transfer coefficient. Its unit is  $\text{W}/\text{m}^2\ ^\circ\text{C}$ . Its value depends on properties of fluid as well as its flow conditions.

### 7.1.3 Radiation

All matter continuously radiates electromagnetic radiation unless its temperature is absolute zero. It is observed that the higher the temperature then the greater amount of energy is radiated. If two bodies at different temperatures are so placed that the radiation from each body is intercepted by the other, then the body at the lower temperature will receive more energy than it is radiating, and hence its internal energy will increase; similarly, the internal energy of the body at a higher temperature will decrease. Thus, there is a net transfer of energy from the high-temperature body to low-temperature body by virtue of the temperature difference between the bodies. Radiant energy, being electromagnetic radiation, requires no medium for its propagation, and will pass through a vacuum. Heat transfer by radiation is most frequent between solid surfaces, although radiation from gases also occurs.

#### *Stefan–Boltzmann Law of Thermal Radiation*

The law states that the rate of radiation heat transfer per unit area from a black surface is directly proportional to fourth power of the absolute temperature of the surface and is given by

$$\frac{Q}{A} \propto T_s^4 \quad \text{or} \quad \frac{Q}{A} = \sigma T_s^4$$

where  $T_s$  is absolute temperature in K; and  $\sigma$  is proportionality constant and called as Stefan–Boltzman constant equal to  $5.67 \times 10^{-8} \text{ W}/\text{m}^2\text{K}^4$ . The heat flux emitted by a real surface is less than that of black surface and is given by,

$$\frac{Q}{A} = \sigma \epsilon T_s^4$$

where  $\epsilon$  is radiative properties of surface, called emissivity.

The net rate of radiation heat exchange between a real surface and its surrounding is

$$\frac{Q}{A} = \sigma \epsilon (T_s^4 - T_\infty^4);$$

where  $T_\infty$  and  $T_s$  are surrounding and surface temperature in K, respectively.

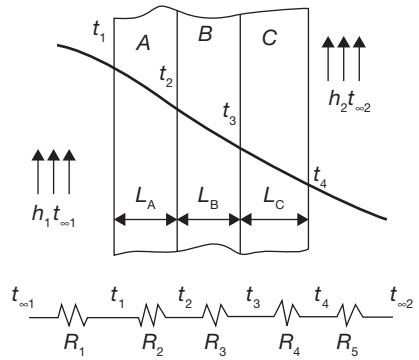
## 7.1.4 Combined Heat Transfer

### Plane Walls with Convection on Sides

There are many cases in practice when different materials are constructed in layers to form a composite wall. This wall may be composed of plaster layer, bricklayer, tiles layer, etc. as shown in Figure 7.3.

In Figure 7.3 there are three layers A, B, C, of thickness  $L_A$ ,  $L_B$ , and  $L_C$ , respectively. The thermal conductivities of the layers are  $k_A$ ,  $k_B$ , and  $k_C$ . On one side of the composite wall, there is a fluid at temperature  $t_{\infty 1}$  and heat transfer coefficient from fluid to the wall is  $h_1$ ; on another side of the composite wall there is fluid at temperature  $t_{\infty 2}$  and the heat transfer coefficient from fluid to the wall is  $h_2$ . Let the temperature of the wall in contact with fluid on one side is  $t_1$  and on other side  $t_4$ . The interface temperatures of the composite wall are  $t_2$  and  $t_3$ . To solve the heat flow problem an analog of electrical current may be used. The heat flow is caused by temperature difference whereas the current flow is caused by a potential difference. Hence, it is possible to postulate a thermal resistance analog to an electrical resistance. From Ohm's law we have,  $V = IR$  or  $I = V/R$ ; where  $V$  is a potential difference,  $I$  is the current, and  $R$  is the resistance.

Thermal resistance,  $R = \frac{x}{kA}$  and thermal resistance for a fluid film,  $R = \frac{1}{hA}$ ; where  $Q$  is analogs to  $I$  and  $\Delta t$  is analogs to  $\Delta V$ .



**FIGURE 7.3**

Plane Walls with Convection on Sides

$$R_1 = \frac{1}{h_1 A}; R_2 = \frac{L_A}{k_A A}; R_3 = \frac{L_B}{k_B A}; R_4 = \frac{L_C}{k_C A}; R_5 = \frac{1}{h_2 A};$$

$$R = \frac{1}{h_1 A} + \sum \frac{L}{kA} + \frac{1}{h_2 A} = \frac{1}{h_1 A} + \frac{L_A}{k_A A} + \frac{L_B}{k_B A} + \frac{L_C}{k_C A} + \frac{1}{h_2 A}$$

$$\begin{aligned} \text{Thus, } Q &= \frac{t_{\infty 1} - t_{\infty 2}}{R} = \frac{t_{\infty 1} - t_1}{\frac{1}{h_1 A}} = \frac{t_1 - t_2}{\frac{L_A}{k_A A}} = \frac{t_2 - t_3}{\frac{L_B}{k_B A}} = \frac{t_3 - t_4}{\frac{L_C}{k_C A}} = \frac{t_4 - t_{\infty 2}}{\frac{1}{h_2 A}} \\ &= \frac{t_{\infty 1} - t_{\infty 2}}{\frac{1}{h_1 A} + \frac{L_A}{k_A A} + \frac{L_B}{k_B A} + \frac{L_C}{k_C A} + \frac{1}{h_2 A}} \end{aligned}$$

**EXAMPLE 7.2**

Derive the expression for the heat transfer through series and parallel composite walls as shown in Figure 7.4.

**SOLUTION**

The electrical current analogy of the heat transfer is shown in Figure 7.5

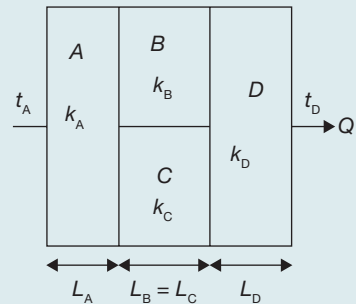
$$R_A = \frac{L_A}{k_A A}; R_B = \frac{L_B}{k_B A_B};$$

$$R_C = \frac{L_C}{k_C A_C}; R_D = \frac{L_D}{k_D A};$$

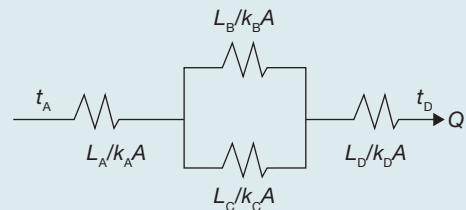
$$R = \sum \frac{L}{kA} = \frac{L_A}{k_A A} + \frac{\frac{L_B}{k_B A_B} \times \frac{L_C}{k_C A_C}}{\frac{L_B}{k_B A_B} + \frac{L_C}{k_C A_C}} + \frac{L_D}{k_D A}$$

$$Q = \frac{t_A - t_D}{R} = \frac{t_A - t_D}{\frac{L_A}{k_A A} + \frac{\frac{L_B}{k_B A_B} \times \frac{L_C}{k_C A_C}}{\frac{L_B}{k_B A_B} + \frac{L_C}{k_C A_C}} + \frac{L_D}{k_D A}};$$

(Here  $A_B = A_C = A/2$ )

**FIGURE 7.4**

Heat Transfer through Composite Wall

**FIGURE 7.5**

Electrical Analogy of Heat Transfer for Composite Wall Shown in Figure 7.4

**EXAMPLE 7.3**

A steel tank of wall thickness 8 mm contains water at 80°C. Calculate the rate of heat loss per m<sup>2</sup> of tank surface area when the atmospheric temperature is 20°C. The thermal conductivity of mild steel is 50 W/mK, and the heat transfer coefficients for the inside and outside of the tank are 2,500 and 20 W/m<sup>2</sup>K, respectively. Also, calculate the temperature of the outside surface of the tank.

**SOLUTION**

$$R = \frac{1}{h_i A} + \frac{x}{kA} + \frac{1}{h_o A} = \frac{1}{A} \left( \frac{1}{h_i} + \frac{x}{k} + \frac{1}{h_o} \right) = \frac{1}{A} \left( \frac{1}{2500 \text{ W/m}^2\text{K}} + \frac{0.008 \text{ m}}{50 \text{ W/mK}} + \frac{1}{20 \text{ W/m}^2\text{K}} \right) = \frac{0.0858}{A}$$

$$q = \frac{Q}{A} = \frac{(80^\circ\text{C} - 20^\circ\text{C})}{0.0858} = 699.3 \text{ W/m}^2$$

$$q = h_o(t_2 - t_o) \Rightarrow 699.3 = 20(t_o - 20)$$

$$t_o = 54.96^\circ\text{C}$$

### EXAMPLE 7.4

A furnace wall consists of 120 mm thick refractory brick and 120 mm thick insulating firebrick separated by an air gap as shown in Figure 7.6. The outside wall is covered with a 10 mm thickness of plaster. The inner surface of the wall is at  $1,000^\circ\text{C}$  and the room temperature is  $20^\circ\text{C}$ . Calculate the rate at which heat is lost per  $\text{m}^2$  of the wall surface. The heat transfer coefficient from the outside wall surface to the air in the room is  $20 \text{ W/m}^2\text{K}$ , and the resistance to heat flow of the air gap is  $0.15 \text{ K/W}$ . The thermal conductivity of refractory brick, insulating firebrick, and plaster are 1.6, 0.3, and  $0.14 \text{ W/mK}$ , respectively. Also, calculate each interface temperature of the outside of the wall.

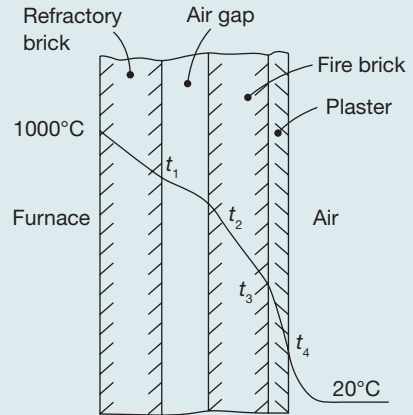


FIGURE 7.6

Composite Walls

### SOLUTION

Given:  $x_{\text{wall}} = 120 \text{ mm};$

$$x_{\text{firebrick}} = 120 \text{ mm}; \quad x_{\text{plaster}} = 10 \text{ mm};$$

$$t_f = 1000^\circ\text{C}; \quad t_a = 20^\circ\text{C}$$

$$h_{fa} = 20 \text{ W/m}^2\text{K}; \quad k_{\text{wall}} = 1.6 \text{ W/mK};$$

$$k_{\text{firebrick}} = 0.3 \text{ W/mK}; \quad k_{\text{plaster}} = 0.14 \text{ W/mK};$$

$$R_{\text{airgap}} = 0.15 \text{ K/W}$$

$$\begin{aligned} R &= R_{\text{wall}} + R_{\text{air gap}} + R_{\text{firebrick}} + R_{\text{plaster}} + \frac{1}{h_{fa}A} \\ &= \frac{0.12 \text{ m}}{1.6 \text{ W/mK}} + 0.15 \text{ K/W} + \frac{0.12 \text{ m}}{0.3 \text{ W/mK}} + \frac{0.01}{0.14 \text{ W/mK}} + \frac{1}{20 \text{ W/m}^2\text{K}} = 0.746 \text{ K/m} \end{aligned}$$

$$q = \frac{t_f - t_a}{R} = \frac{1,000^\circ\text{C} - 20^\circ\text{C}}{0.746 \text{ K/W}} = 1,313.672 \text{ W/m}^2$$

$$q = \frac{t_f - t_1}{R_{\text{wall}}} = h_{\text{air gap}}(t_1 - t_2) = \frac{t_2 - t_3}{R_{\text{firebrick}}} = \frac{t_3 - t_4}{R_{\text{plaster}}} = h_{\text{air}}(t_4 - t_a)$$



$$1,313.672 = \frac{1.6 \text{ W/mK}(1,000^\circ\text{C} - t_1)}{0.12} \quad \text{or, } t_1 = 901.474^\circ\text{C}$$

$$1,313.672 = \frac{(901.474^\circ\text{C} - t_2)}{0.15} \quad \text{or, } t_2 = 704.423^\circ\text{C}$$

$$1,313.672 = \frac{0.3 \text{ W/mK}(704.423^\circ\text{C} - t_3)}{0.12} \quad \text{or, } t_3 = 178.954^\circ\text{C}$$

$$1,313.672 = \frac{0.14 \text{ W/mK}(178.954^\circ\text{C} - t_4)}{0.01} \quad \text{or, } t_4 = 85.12^\circ\text{C}$$

### Heat Transfer through Hollow Cylinder

Consider a cylinder of internal radius  $r_1$  and external radius  $r_2$  as shown in Figure 7.7. Let the inside and outside temperatures be  $t_1$  and  $t_2$ , respectively. Consider the heat flow through a small element of thickness,  $dr$  at any radius  $r$ , where the temperature is  $t$ . Let the thermal conductivity of the material be  $k$ , the temperature of fluid flow inside the cylinder be  $t_{f1}$ , heat transfer coefficient be  $h_{f1}$ , the temperature of fluid flow outside the cylinder be  $t_{f2}$ , and heat transfer coefficient be  $h_{f2}$ , the heat transfer through the elemental area of length  $l$  can be given by:

$$Q = -kA \frac{dt}{dx} = -k2\pi r l \frac{dt}{dr}$$

$$\text{or, } Q \frac{dr}{r} = -k2\pi l dt$$

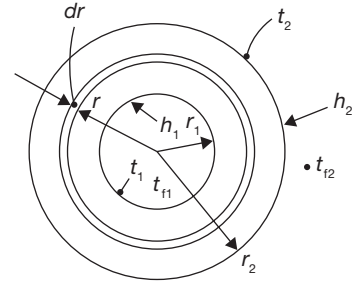
Integrating between the inside and outside surfaces,

$$Q \int_{r_1}^{r_2} \frac{dr}{r} = -k2\pi l \int_{t_1}^{t_2} dt$$

$$\text{or, } Q \log_e \frac{r_2}{r_1} = -k2\pi l(t_2 - t_1) = k2\pi l(t_1 - t_2)$$

$$\text{or, } Q = \frac{k2\pi l(t_1 - t_2)}{\log_e \frac{r_2}{r_1}}$$

$$Q = \frac{k2\pi l(t_1 - t_2)}{\log_e \frac{r_2}{r_1}}; \text{ For the unit length of the cylinder}$$



**FIGURE 7.7**

Heat Transfer through Cylindrical Wall

If we put mean area  $A_m$  and mean radius  $r_m$  in the earlier equation as:

$$A_m = \frac{2\pi(r_2 - r_1)}{\log_e \frac{r_2}{r_1}} = \frac{A_2 - A_1}{\log_e \frac{r_2}{r_1}}; \text{ and}$$

$$r_m = \frac{r_2 - r_1}{\log_e \frac{r_2}{r_1}}$$

In the case of a composite cylinder the most convenient approach is again that of the electrical analogy; by using  $R = \frac{x}{kA_m} = \frac{\log_e \frac{r_2}{r_1}}{2\pi k}$ ; where  $x$  is the thickness of a layer and  $A_m$  is the logarithmic mean area for that layer.

The film of fluid on the inside and outside surfaces can be treated as:

$$R_{inside} = \frac{1}{h_1 A_1} \text{ and } R_{outside} = \frac{1}{h_2 A_2}$$

### EXAMPLE 7.5

A steel pipe of 80 mm bore and 8 mm wall thickness, carrying steam at 250 °C, is insulated with 36 mm of a molded high-temperature diatomaceous earth covering. This covering is in turn insulated with 50 mm of asbestos felt. If the atmospheric temperature is 20 °C, calculate the rate at which heat is lost by the steam per meter length of pipe. The heat transfer coefficients for the inside and outside surfaces are 525 and 27 W/m<sup>2</sup>K, respectively, and the thermal conductivity of steel, diatomaceous earth, and asbestos felt are 55, 0.1, and 0.08 W/mK, respectively. Also, calculate the temperature of the outside surface.

### SOLUTION

Given:  $r_i = 40$  mm;  $r_1 = 48$  mm;  $r_2 = 84$  mm;  $r_o = 134$  mm;  $h_i = 525$  W/m<sup>2</sup>K;  $m^2K = 2$  W/m<sup>2</sup>K

$$R = \frac{1}{h_i A_i} + R_{steel} + R_{diatomaceous} + R_{asbestos} + \frac{1}{h_o A_o}$$

Now resistance of per unit length of pipe

$$R = \frac{1}{h_i 2\pi r_i} + \frac{\log_e \left( \frac{r_1}{r_i} \right)}{2\pi k_{steel}} + \frac{\log_e \left( \frac{r_2}{r_1} \right)}{2\pi k_{diatomaceous}} + \frac{\log_e \left( \frac{r_o}{r_2} \right)}{2\pi k_{asbestos}} + \frac{1}{h_o 2\pi r_o}$$

$$= \frac{10^3}{525 \text{ W/m}^2\text{K} \times 2\pi \times 40\text{mm}} + \frac{\log_e \left( \frac{48 \text{ mm}}{40\text{mm}} \right)}{2\pi \times 55 \text{ W/mK}} + \frac{\log_e \left( \frac{84 \text{ mm}}{48\text{mm}} \right)}{2\pi \times 0.1 \text{ W/mK}} + \frac{\log_e \left( \frac{134 \text{ mm}}{84\text{mm}} \right)}{2\pi \times 0.08 \text{ W/mK}}$$

$$+ \frac{10^3}{27 \text{ W/m}^2\text{K} \times 2\pi \times 134\text{mm}} \text{ K/W}$$

$$\begin{aligned}
 &= 0.0007582 \text{ K/W} + 0.000229245 \text{ K/W} + 0.387063 \text{ K/W} \\
 &\quad + 0.403713 \text{ K/W} + 0.044012 \text{ K/W} \\
 &= \mathbf{0.8357 \text{ K/W}}
 \end{aligned}$$

$$Q = \frac{t_{fi} - t_{fo}}{R} = \frac{250^\circ\text{C} - 20^\circ\text{C}}{0.8357 \text{ K/W}} = 242.91 \text{ W per meter of length.}$$

$$Q = 242.91 \text{ W} = \frac{t_o - t_{fo}}{h_o A_o} = \frac{t_o - 20}{0.044012}$$

$$\text{or, } t_o = \mathbf{30.69^\circ\text{C}}$$

### Heat Transfer through Hollow Sphere

Consider a hollow sphere of internal radius  $r_1$  and external radius  $r_2$  as shown in Figure 7.8. Let the inside and outside surface temperature be  $t_1$  and  $t_2$ ; and let the thermal conductivity be  $k$ . Consider a small element of thickness,  $dr$  at any radius  $r$ . It can be shown that the surface area of this spherical element is given by  $4\pi r^2$ . The heat transfer rate

$$Q = -kA \frac{dt}{dr} = -k4\pi r^2 \frac{dt}{dr}$$

$$\text{or, } Q \frac{dr}{r^2} = -k4\pi dt$$

On integrating, we get

$$Q \int_{r_1}^{r_2} \frac{dr}{r^2} = -k4\pi \int_{t_1}^{t_2} dt$$

$$\text{or, } Q \frac{r_2 - r_1}{r_1 r_2} = k4\pi(t_1 - t_2)$$

$$\text{or, } Q = \frac{4\pi k r_1 r_2 (t_1 - t_2)}{r_2 - r_1}$$

Applying electrical analogy we get,

$$R = \frac{r_2 - r_1}{4\pi k r_1 r_2}$$

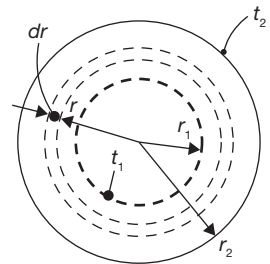
If the concepts of mean area,  $A_m$  and mean radius,  $r_m$  are applied

$$Q = \frac{kA_m(t_1 - t_2)}{x} = \frac{kA_m(t_1 - t_2)}{r_2 - r_1}$$

where,

$$A_m = 4\pi r_m^2 = 4\pi r_1 r_2; \text{ and } r_m = \sqrt{r_1 r_2}$$

$r_m$  is geometric mean.



**FIGURE 7.8**

Heat Transfer through Sphere

**EXAMPLE 7.6**

A small hemispherical oven is built of an inner layer of insulating firebrick 120 mm thick, and an outer covering 80% magnesia 40 mm thick. The inner surface of the oven is 820°C and the heat transfer coefficient for the outside surface is 10 W/m<sup>2</sup>K; the room temperature is 22°C. Calculate the heat loss through the hemisphere, if the inside radius is 0.8 m. Take the thermal conductivities of firebrick and 80% magnesia as 0.31 and 0.05 W/mK.

**SOLUTION**

Given:

$$r_i = 0.8 \text{ m}; r_1 = 0.92 \text{ m}; r_3 = 0.96 \text{ m};$$

$$t_i = 820^\circ \text{C}; t_o = 22^\circ \text{C}; h_{\text{air}} = 10 \text{ W/m}^2 \text{K}$$

$$k_{\text{firebrick}} = 0.31 \text{ W/mK}; k_{\text{magnesia}} = 0.05 \text{ W/mK}$$

$$R = R_{\text{firebrick}} + R_{\text{magnesia}} + R_{\text{air}}$$

$$= \frac{0.12 \text{ m}}{4\pi \times 0.31 \text{ W/mK} \times 0.8 \text{ m} \times 0.92 \text{ m}} + \frac{0.04 \text{ m}}{4\pi \times 0.05 \text{ W/mK} \times 0.92 \text{ m} \times 0.96 \text{ m}}$$

$$+ \frac{1}{10 \text{ W/m}^2 \text{K} \times 4\pi \times (0.96 \text{ m})^2}$$

$$= 0.0418 + 0.0721 + 0.00863 = 0.12253 \text{ K/W}$$

$$Q = \frac{820^\circ \text{C} - 22^\circ \text{C}}{0.122 \text{ K/W}} = 6540.98 \text{ W} = \mathbf{6.54 \text{ kW}}$$

**RECAP ZONE** .....**Points to Remember**

- From the second law of thermodynamics, the heat flows whenever there is the existence of temperature difference or temperature gradient.
- **Heat** is a form of energy, which is transferred from one body to another body at a lower temperature, by virtue of the temperature difference between the bodies.
- Conduction is the heat transfer from one part of a substance to another part of the same substance, or from one substance to another in Physical contact with it, without appreciable displacement of the molecules forming the substance.
- The heat transfer in conduction mode at a macroscopic level and use a phenomenological law is based on experiments of Biot and formulated by J.B. Fourier in 1882.
- Convection is the term used for heat transfer mechanism which takes place in a fluid because of a combination of conduction due to the molecular interactions and energy transport due to the macroscopic motion of the fluid itself.
- All matter continuously radiates electromagnetic radiation unless its temperature is absolute zero.

## Important Formulae

$$1. \quad q = \frac{Q}{A} = -k \frac{dt}{dx}$$

$$2. \quad Q = h.A.(t_s - t_\infty)$$

$$3. \quad \frac{Q}{A} = \sigma \epsilon (T_s^4 - T_\infty^4)$$

$$4. \quad Q = \frac{k2\pi(t_1 - t_2)}{\log_e \frac{r_2}{r_1}}; \text{ For unit length of the cylinder}$$

$$5. \quad A_m = \frac{2\pi(r_2 - r_1)}{\log_e \frac{r_2}{r_1}} = \frac{A_2 - A_1}{\log_e \frac{r_2}{r_1}}$$

$$6. \quad r_m = \frac{r_2 - r_1}{\log_e \frac{r_2}{r_1}}$$

$$7. \quad Q = \frac{kA_m(t_1 - t_2)}{x} = \frac{kA_m(t_1 - t_2)}{r_2 - r_1}$$

$$8. \quad A_m = 4\pi r_m^2 = 4\pi r_1 r_2; \text{ and } r_m = \sqrt{r_1 r_2}$$

$$9. \quad Q = 2\pi r l U \frac{(\theta_1 - \theta_2)}{\log_e \frac{\theta_1}{\theta_2}}$$

$$10. \quad Q = UA\theta_m$$

$$11. \quad \theta_m = \frac{(\theta_1 - \theta_2)}{\log_e \frac{\theta_1}{\theta_2}}$$

## REVIEW ZONE .....



### Multiple-choice Questions

- |   |  |
|---|--|
| <p>1. Heat transfer takes place as per:</p> <p>(a) Zeroth law of thermodynamics<br/>         (b) First law of thermodynamics<br/>         (c) Second law of thermodynamics<br/>         (d) All the three</p> | <p>2. When heat is transferred from one particle of hot body to another by actual motion of the heated particles, it is referred to as heat transfer by:</p> <p>(a) Conduction            (b) Convection<br/>         (c) Radiation              (d) None of these</p> |
|---|--|

3. When heat is transferred from hot body to cold body, in a straight line, without affecting the intervening medium, it is referred to as heat transfer by:
- (a) Conduction (b) Convection  
(c) Radiation (d) None of these
4. Heat transfer in liquids and gases takes place by:
- (a) Conduction (b) Convection  
(c) Radiation (d) None of these
5. When heat is transferred by molecular collision, it is referred to as heat transfer by:
- (a) Conduction (b) Convection  
(c) Radiation (d) None of these
6. Heat flows from one body to other when they have:
- (a) Different heat contents  
(b) Different specific heat  
(c) Different atomic structure  
(d) Different temperature
7. The amount of heat flow through a body by conduction is:
- (a) Directly proportional to the surface area of the body  
(b) Dependent upon material of the body  
(c) Directly proportional to the temperature difference:  
(d) All of the above
8. Thermal conductivity of a material may be defined as the:
- (a) Quantity of heat flowing in one second through one cubic meter of material when opposite faces are maintained at a temperature difference of 1°C.  
(b) Quantity of heat flowing in one second through one square meter of the area and of 1 m thickness of material when opposite faces are maintained at a temperature difference of 1°C.  
(c) Both  
(d) None of these
9. Heat transfer by radiation mainly depends upon:
- (a) Its temperature  
(b) Nature of the body  
(c) Kind and extent of its surface  
(d) All of the above
10. If two surfaces of area A distance L apart, of a material having thermal conductivity k, are at temperatures  $t_1$  and  $t_2$  then heat flow rate through it will be:
- (a)  $kA(t_1-t_2)/L$  (b)  $LA(t_1-t_2)/k$   
(c)  $Lk(t_1-t_2)/A$  (d) None of these
11. According to Stefan's Law, the total radiation from a black body per second per unit area is proportional to:
- (a) T (b)  $T^2$   
(c)  $T^3$  (d)  $T^4$
12. If the inner and outer surfaces of a hollow cylinder (having radii  $r_1$  and  $r_2$  and length L) are at temperature  $t_1$  and  $t_2$ , then rate of radial heat flow will be:
- (a)  $\frac{k}{2\pi L} \cdot \frac{t_1-t_2}{\log_e \frac{r_2}{r_1}}$  (b)  $\frac{1}{2\pi kL} \cdot \frac{t_1-t_2}{\log_e \frac{r_2}{r_1}}$   
(c)  $\frac{2\pi L}{k} \cdot \frac{t_1-t_2}{\log_e \frac{r_2}{r_1}}$  (d)  $2\pi kL \cdot \frac{t_1-t_2}{\log_e \frac{r_2}{r_1}}$
13. If the inner and outer walls of a hollow sphere having surface areas of  $A_1$  and  $A_2$ , and inner and outer radii  $r_1$  and  $r_2$ , are maintained at temperatures  $t_1$  and  $t_2$ , then rate of heat flow will be:
- (a)  $k\sqrt{A_1A_2} \cdot \frac{t_1-t_2}{r_2-r_1}$  (b)  $\frac{k}{\sqrt{A_1A_2}} \cdot \frac{t_1-t_2}{r_2-r_1}$   
(c)  $\frac{4\pi k}{\sqrt{A_1A_2}} \cdot \frac{t_1-t_2}{r_2-r_1}$  (d)  $\frac{4\pi k r_1 r_2}{\sqrt{A_1A_2}} \cdot \frac{t_1-t_2}{r_2-r_1}$
14. LMTD for a heat exchanger is given by:
- (a)  $\frac{\Delta t_2 - \Delta t_1}{\log_e \frac{\Delta t_2}{\Delta t_1}}$  (b)  $\frac{\Delta t_2 - \Delta t_1}{\log_e \frac{\Delta t_1}{\Delta t_2}}$   
(c) Both (d) None of these
15. The heat flow equation through a sphere of inner radius  $r_1$  and outer radius  $r_2$  is to be written in the same form as that for heat flow through a plane wall. For wall thickness  $(r_2-r_1)$ , the equivalent mean radius for the spherical shell is:
- (a)  $\frac{r_1+r_2}{2}$  (b)  $r_1 r_2$   
(c)  $\sqrt{r_1 r_2}$  (d)  $\frac{r_1+r_2}{\log_e (r_2/r_1)}$

## Answers

1. (c)      2. (a)      3. (c)      4. (b)      5. (a)      6. (d)  
7. (d)      8. (c)      9. (d)      10. (a)      11. (d)      12. (d)  
13. (a)      14. (a)      15. (c)

## Theory Questions

1. What do you mean by heat transfer? Explain its applications in engineering.
2. Explain the different modes of heat transfer.
3. Derive the expression for heat flow in steady state conduction without heat generation using Fourier Law.
4. Explain Newton's law of cooling and derive the heat flow in convection.
5. Explain Stefan and Boltzmann's law of and derive the heat flow in convection.

## Numerical Problems

1. The inner surface of a plain brick wall is at  $80^{\circ}\text{C}$  and the outer surface is at  $30^{\circ}\text{C}$ . Calculate the rate of heat transfer per  $\text{m}^2$  of the surface area of the wall, which is 280 mm thick. The thermal conductivity of the brick is  $0.75 \text{ W/mK}$ .
2. A steel tank of wall thickness 10 mm contains water at  $90^{\circ}\text{C}$ . Calculate the rate of heat loss per  $\text{m}^2$  of tank surface area when the atmospheric temperature is  $15^{\circ}\text{C}$ . The thermal conductivity of mild steel is  $55 \text{ W/mK}$ , and the heat transfer coefficients for the inside and outside of the tank are 2,550 and  $24 \text{ W/m}^2\text{K}$ , respectively. Also, calculate the temperature of the outside surface of the tank.
3. A furnace wall consists of 100 mm thick refractory brick and 800 mm thick insulating firebrick separated by an air gap. The outside wall is covered with a 20 mm thickness of plaster. The inner surface of the wall is at  $1,100^{\circ}\text{C}$  and the room temperature is  $26^{\circ}\text{C}$ . Calculate the rate at which heat is lost per  $\text{m}^2$  of the wall surface. The heat transfer coefficient from the outside wall surface to the air in the room is  $22 \text{ W/m}^2\text{K}$ , and the resistance to heat flow of the air gap is  $0.16 \text{ K/W}$ . The thermal conductivity of refractory brick, insulating firebrick, and plaster are 1.5, 0.25, and  $0.13 \text{ W/mK}$ , respectively. Also, calculate each interface temperature of the outside of the wall.
4. A steel pipe of 100 mm bore and 10 mm wall thickness, carrying steam at  $250^{\circ}\text{C}$ , is insulated with 30 mm of a molded high-temperature diatomaceous earth covering. This covering is in turn insulated with 60 mm of asbestos felt. If the atmospheric temperature is  $22^{\circ}\text{C}$ , calculate the rate at which heat is lost by the steam per meter length of pipe. The heat transfer coefficients for the inside and outside surfaces are 520 and  $28 \text{ W/m}^2\text{K}$ , respectively, and the thermal conductivity of steel, diatomaceous earth, and asbestos felt are 54, 0.12, and  $0.09 \text{ W/mK}$ , respectively. Also, calculate the temperature of the outside surface.
5. A small hemispherical oven is built of an inner layer of insulating firebrick 110 mm thick, and an outer covering 80% magnesia 45 mm thick. The inner surface of the oven is  $850^{\circ}\text{C}$  and the heat transfer coefficient for the outside surface is  $12 \text{ W/m}^2\text{K}$ ; the room temperature is  $26^{\circ}\text{C}$ . Calculate the heat loss through the hemisphere, if the inside radius is 1.0 m. Take the thermal conductivities of firebrick and 80% magnesia as 0.32 and  $0.06 \text{ W/mK}$ .

# Refrigeration and Air Conditioning

## Learning Objectives

*By the end of this chapter, the student will be able:*

- To understand the basic concepts of refrigeration and air conditioning
- To describe the different types of refrigeration cycles
- To demonstrate the structure and working of a household refrigerator
- To understand the properties of air-vapour mixture
- To differentiate the working of the window and split air conditioners

## 8.1 ► INTRODUCTION

Initially, the main purpose of refrigeration was to conserve foods. The Chinese were the first to find out that ice increased the life and improved the taste of drinks and for centuries Eskimos have conserved food by freezing it. At the beginning of the 19<sup>th</sup> century, it had been observed that the growth of microorganisms is temperature-dependent, that growth declines as temperature falls, and that growth becomes very slow at temperatures below +10°C. As a consequence of this knowledge, it was now possible to use refrigeration to conserve food-stuffs and natural ice came into use for this purpose.

The idea of air conditioning started before a machine was created to produce the cooling effect desired. The first attempt at building an air conditioner was made by Dr. John Gorrie (1803–1855), an American physician, in Apalachicola, Florida. During his practice there in the 1830s, Dr. Gorrie creating an ice-making machine that essentially blew air over a bucket of ice for cooling hospital rooms of patients suffering from malaria and yellow fever.



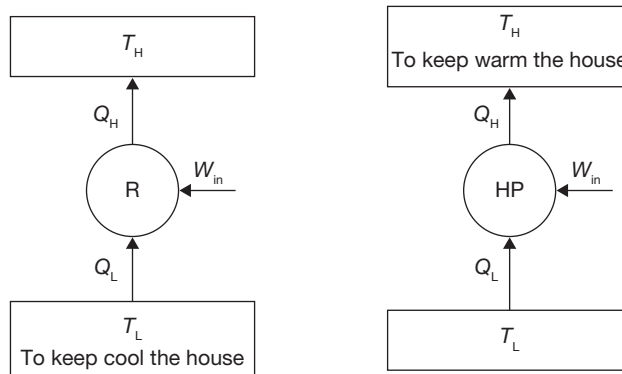
## 8.2 ► REFRIGERATOR AND HEAT PUMP

Clausius, statement of the Second Law of Thermodynamics: *It is impossible to construct a device that, operating in a cycle, has no effect other than the transfer of heat from a cooler to a hotter body.* Thus, the Clausius statement tells us that heat will not flow from cold to hot regions without the assistance of outside agents. The devices that provide this assistance are called *refrigerators* and *heat pumps*. The working of refrigeration and heat pump is shown in Figure 8.1. The distinction between refrigerator and heat pump is one of purpose more than technique. The refrigeration unit transfers heat from cold to hot regions for the purpose of cooling the cold region while the heat pump does the same thing with the intent of heating the hot region. The performance of the refrigerators and the heat pump is expressed in terms of the Coefficient of Performance (COP), which is defined as:

$$COP_R = \frac{\text{Desired output}}{\text{Required input}} = \frac{\text{Cooling effect}}{\text{Work input}} = \frac{Q_L}{W_{in}}$$

$$COP_{HP} = \frac{\text{Desired output}}{\text{Required input}} = \frac{\text{Heating effect}}{\text{Work input}} = \frac{Q_H}{W_{in}}$$

$$COP_{HP} = COP_R + 1$$



**FIGURE 8.1**

Working of Refrigeration and Heat Pump

**Tones of Refrigeration (TR):** the cooling effect produced is quantified as tons of refrigeration, also referred to as “chiller tonnage”.

$$TR = Q \times C_p \times (T_i - T_o)/3024 = 210 \text{ kJ/min or } 3.5 \text{ kJ/s.}$$

Where  $Q$  - mass flow rate of coolant in  $kg/h$

$C_p$  - coolant specific heat in  $kCal/kg\ ^\circ C$

$T_i$  - inlet temperature of coolant to the evaporator (chiller) in  $^\circ C$

$T_o$  - outlet temperature of coolant from the evaporator (chiller) in  $^\circ C$ .

1 TR of refrigeration = 3,024  $kCal/h$  heat rejected

Power of unit of refrigerator =  $Q_L/COP$

Capacity of refrigeration plant = Heat removal rate in tones.

## 8.3 ► COMPONENTS OF REFRIGERATION SYSTEM

There are five basic components of a refrigeration system, these are:

- Evaporator
- Compressor
- Condenser
- Expansion valve
- Refrigerant; to conduct the heat from the product in order for the refrigeration cycle to operate successfully each component must be present within the refrigeration system.

### 8.3.1 Evaporator

The purpose of the evaporator is to remove unwanted heat from the product, via the liquid refrigerant. The liquid refrigerant contained within the evaporator is boiling at a low-pressure. The level of this pressure is determined by two factors:

- The rate at which the heat is absorbed from the product to the liquid refrigerant in the evaporator.
- The rate at which the low-pressure vapor is removed from the evaporator by the compressor to enable the transfer of heat, the temperature of the liquid refrigerant must be lower than the temperature of the product being cooled. Once transferred, the liquid refrigerant is drawn from the evaporator by the compressor via the suction line. When leaving the evaporator coil the liquid refrigerant is in vapor form.

### 8.3.2 Compressor

The purpose of the compressor is to draw the low-temperature, low-pressure vapor from the evaporator via the suction line. Once drawn, the vapor is compressed. When vapor is compressed it rises in temperature. Therefore, the compressor transforms the vapor from a low-temperature vapor to a high-temperature vapor, in turn increasing the pressure. The vapor is then released from the compressor into the discharge line.

### 8.3.3 Condenser

The purpose of the condenser is to extract heat from the refrigerant to the outside air. The condenser is usually installed on the reinforced roof of the building, which enables the transfer of heat. Fans mounted above the condenser unit are used to draw air through the condenser coils. The temperature of the high-pressure vapor determines the temperature at which the condensation begins. As heat has to flow from the condenser to the air, the condensation temperature must be higher than that of the air; usually between  $-12^{\circ}\text{C}$  and  $-1^{\circ}\text{C}$ . The high-pressure vapor within the condenser is then cooled to the point where it becomes a liquid refrigerant once more, whilst retaining some heat. The liquid refrigerant then flows from the condenser in to the liquid line.

### 8.3.4 Expansion Valve

Within the refrigeration system, the expansion valve is located at the end of the liquid line, before the evaporator. The high-pressure liquid reaches the expansion valve, having come from the condenser. The valve then reduces the pressure of the refrigerant as it passes through the orifice, which is located inside the valve. On reducing the pressure, the temperature of the refrigerant also decreases to a level below the surrounding air. This low-pressure, low-temperature liquid is then pumped in to the evaporator.

## 8.4 ► TYPES OF REFRIGERATION SYSTEMS

Broadly, the refrigeration systems can be categorized as:

- Air-refrigeration system
- Vapor compression refrigeration system
- Absorption refrigeration system

### 8.4.1 Air-refrigeration System

#### *Reversed Carnot Cycle*

Reversed Carnot cycle is shown in Figure 8.2. It consists of the following processes. *Process a-b*: Absorption of heat by the working fluid from the refrigerator at constant low-temperature  $T_L$  during isothermal expansion.

*Process b-c*: Isentropic compression of the working fluid with the aid of external work. The temperature of the fluid rises from  $T_L$  to  $T_H$ .

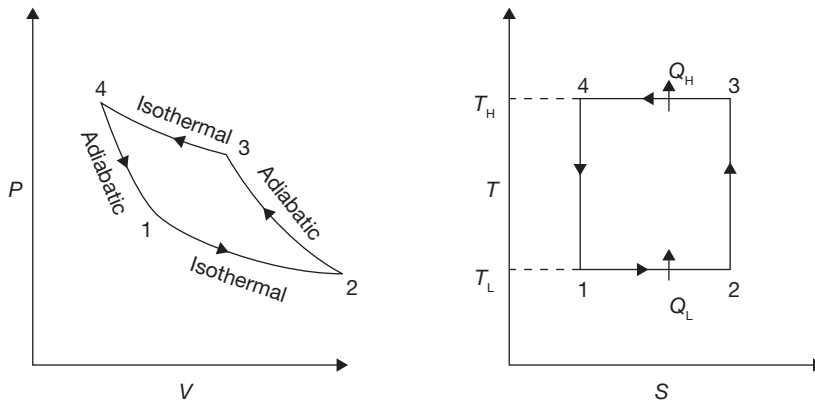
*Process c-d*: Isothermal compression of the working fluid during which heat is rejected at constant high-temperature  $T_H$ .

**Process d-a:** Isentropic expansion of the working fluid. The temperature of the working fluid falls from  $T_H$  to  $T_L$ .

**COP of Refrigerator:**

$$\begin{aligned} \text{COP} &= \frac{\text{Heat absorbed}}{\text{Work supplied}} = \frac{\text{Heat absorbed}}{\text{Heat rejected} - \text{Heat absorbed}} \\ &= \frac{T_L(S_2 - S_1)}{T_H(S_2 - S_1) - T_L(S_2 - S_1)} = \frac{T_L}{T_H - T_L} \end{aligned}$$

Practical use of the reversed Carnot cycle is not possible for refrigeration purpose as the isentropic process requires a very high-speed operation, whereas the isothermal process requires a very low-speed operation.



**FIGURE 8.2**

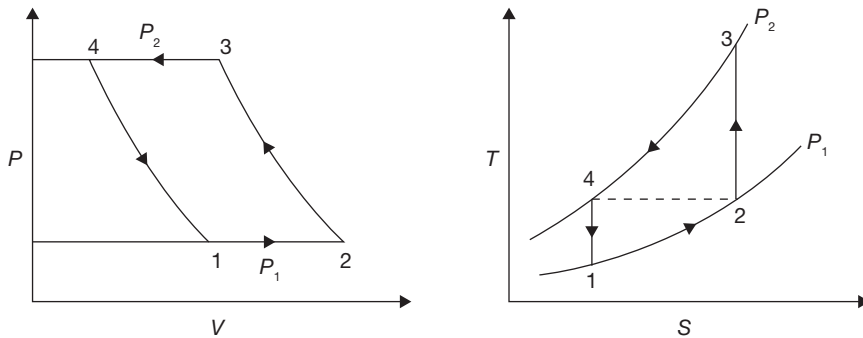
P-V and T-S Diagrams for Reversed Carnot Cycle

### *Bell–Coleman Cycle or Reversed Brayton Cycle*

In this system, air is taken into the compressor from the atmosphere and compressed then the hot compressed air is cooled in heat exchanger up to the atmospheric temperature. The cooled air is then expanded in an expander. The temperature of the air coming out from the expander is below the atmospheric temperature due to isentropic expansion. The low-temperature air coming out from the expander enters into the evaporator and absorbs the heat. The cycle is repeated again and again. The working of Reversed Brayton Cycle is represented on P-V and T-S diagrams in Figure 8.3.

**Process 1-2:** Suction of air into the compressor.

**Process 2-3:** Isentropic compression of air by the compressor.


**FIGURE 8.3**

Reversed Brayton Cycle

**Process 3-4:** Discharge of high-pressure air from the compressor into the heat exchanger (The reduction in the volume of air from  $V_3$  to  $V_4$  is due to the cooling of air in the heat exchanger.)

**Process 4-1:** Isentropic expansion of air in the expander.

**Process 1-2:** Absorption of heat from the evaporator at constant pressure and suction of air into the compressor.

$$\text{COP} = \frac{\text{Net refrigeration effect}}{\text{Net work supplied}}$$

Work done per kg of air for the isentropic compression process 2-3 is given by:

$$W_{\text{comp}} = C_p(T_3 - T_2)$$

Work developed per kg of air for the isentropic expansion process 4-1 is given by:

$$W_{\text{exp}} = C_p(T_4 - T_1)$$

$$W_{\text{net}} = (W_{\text{comp}} - W_{\text{exp}}) = C_p(T_3 - T_2) - C_p(T_4 - T_1)$$

Net refrigerating effect per kg of air is given by:

$$R_{\text{net}} = C_p(T_2 - T_1)$$

$$\text{COP} = \frac{R_{\text{net}}}{W_{\text{net}}} = \frac{C_p(T_2 - T_1)}{C_p\{(T_3 - T_2) - (T_4 - T_1)\}}$$

For perfect inter-cooling, the required condition is  $T_4 = T_2$

$$\text{COP} = \frac{(T_2 - T_1)}{(T_3 - T_2) - (T_4 - T_1)} = 1 / \frac{T_3(1 - \frac{T_2}{T_3})}{T_2(1 - \frac{T_1}{T_2})} - 1$$

For isentropic compression process 2-3 and for expansion process 5-6, we have,

$$\frac{T_3}{T_2} = \left(\frac{P_2}{P_1}\right)^{\frac{\gamma-1}{\gamma}} = \frac{T_4}{T_1}$$

$$\Rightarrow \text{COP} = \frac{T_2}{T_3 - T_2}$$

### Advantages and Disadvantages of Air-refrigeration System

#### Advantages

- ▶ Air is a cheaper refrigerant and available easily compared to other refrigerants. There is no danger of fire or toxic effects due to leakage.
- ▶ The total weight of the system per ton of refrigerating capacity is less.

#### Disadvantages:

- ▶ The quantity of air required per ton refrigerating capacity is far greater than other systems. The COP is low and hence maintenance cost is high. The danger of frosting at the expander valves is more as the air taken into the system always contains moisture.

### EXAMPLE 8.1

Carnot refrigeration cycle absorbs heat at 250 K and rejects heat at 300 K.

- (a) Calculate the coefficient of performance of this refrigeration cycle.
- (b) If the cycle is absorbing 1,050 kJ/min at 250 K, how many kJ of work is required per second.
- (c) If the Carnot heat pump operates between the same temperatures as the above refrigeration cycle, what is the coefficient of performance?
- (d) How many kJ/min will the heat pump deliver at 300 K if it absorbs 1,050 kJ/min at 250 K.

### SOLUTION

Given:  $T_1 = 250$  K;  $T_2 = 300$  K

- (a) Coefficient of performance of Carnot refrigeration cycle We know that coefficient of performance of Carnot refrigeration cycle,

$$(\text{COP})_R = \frac{T_1}{T_2 - T_1} = \frac{250\text{ K}}{300\text{ K} - 250\text{ K}} = 5$$

- (b) Work required per second

Let  $W_R =$  Work required per second

Heat absorbed at 250 K (i.e.,  $T_1$ ),  $Q_1 = 1050 \text{ kJ/min} = 17.5 \text{ kJ/s}$

$$\text{We know that } (\text{COP})_R = \frac{Q_1}{W_R} \Rightarrow W_R = \frac{Q_1}{(\text{COP})_R} = \frac{17.5 \text{ kJ/s}}{5}$$

$$W_R = 3.5 \text{ kJ/s}$$

(c) Coefficient of performance of Carnot heat pump

We know that coefficient of performance of a Carnot heat pump,

$$(\text{COP})_P = \frac{T_2}{T_2 - T_1} = \frac{300 \text{ K}}{300 \text{ K} - 250 \text{ K}} = 6$$

(d) Heat delivered by heat pump at 300 K

Let  $Q_2$  = Heat delivered by heat pump at 300 K.

Heat absorbed at 250 K (i.e.,  $T_1$ ),

$Q_1 = 1050 \text{ kJ/min}$  (Given)

$$(\text{COP})_P = \frac{Q_2}{Q_2 - Q_1} = \frac{Q_2}{Q_2 - 1050 \text{ kJ/min}} = 6 \Rightarrow Q_2 = 1,260 \text{ kJ/min.}$$

### EXAMPLE 8.2

The capacity of a refrigerator is 150 TR when working between  $-5^\circ\text{C}$  and  $20^\circ\text{C}$ . Determine the mass of ice produced per day from water at  $20^\circ\text{C}$ . Also, find the power required to drive the unit. Assume that the cycle operates on reversed Carnot cycle and latent heat of ice is  $336 \text{ kJ/kg}$ .

### SOLUTION

Given:  $Q = 150 \text{ TR}$ ;  $T_1 = -5^\circ\text{C} = -5^\circ\text{C} + 273 = 268 \text{ K}$ ;  $T_2 = 20^\circ\text{C} = 20 + 273 = 293 \text{ K}$

Mass of ice produced per day

Heat extraction capacity of the refrigerator =  $150 \text{ TR} \times 210 \text{ kJ/min} = 31,500 \text{ kJ/min}$

Heat removed from 1 kg of water at  $20^\circ\text{C}$  to form ice at  $0^\circ\text{C}$  ( $\text{ITR} = 210 \text{ kJ/min}$ )

$$= \text{Mass} \times \text{Sp. Heat} \times (\text{Change in Temperature}) + h_{fg} \text{ (ice)}$$

$$\text{Heat} = 1 \times 4.18 \text{ kJ/kgK} \times 20^\circ\text{C} + 336 \text{ kJ/kg} = 419.6 \text{ kJ/kg}$$

Mass of ice produced per min =  $31,500 \text{ kJ/min} / 419.6 \text{ kJ/kg} = 75.07 \text{ kg/min}$ .

Mass of ice produced per day =  $75.07 \text{ kg/min} \times 60 \text{ min} \times 24 \text{ hours}$

$$= 108,102.95 \text{ kg} = \mathbf{108.10 \text{ tonnes}}$$

$$(\text{COP})_R = \frac{T_1}{T_2 - T_1} = \frac{268\text{ K}}{293\text{ K} - 268\text{ K}} = 10.72$$

$$(\text{COP})_R = \frac{\text{Heat extraction capacity}}{\text{Work done per min}}$$

$$\text{Work done per min.} = \frac{31,500\text{ kJ/min}}{10.72} = 2,938.43\text{ kJ/min}$$

$$\text{Power required to drive the unit} = \frac{2,938.43\text{ kJ/min}}{60} = \mathbf{48.97\text{ kW}}$$

### 8.4.2 Vapour Compression Refrigeration System

A simple vapor compression refrigeration system consists of the following equipments (Figure 8.4):

- (i) Compressor,
- (ii) Condenser,
- (iii) Expansion valve,
- (iv) Evaporator.

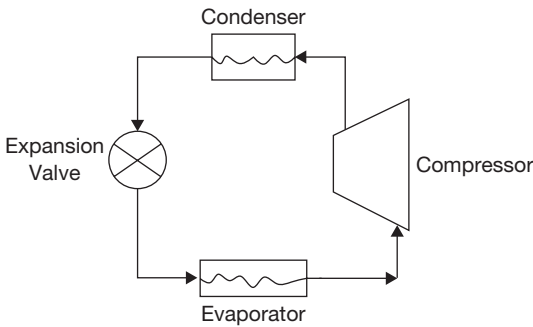
The low-temperature and low-pressure vapor is compressed by a compressor to high-temperature and high-pressure vapor. This vapor is then condensed into condenser at constant pressure and then passes through the expansion valve. Here, the vapor is throttled down to a low-pressure liquid and passed through an evaporator, where it absorbs heat from the surroundings and vaporizes into low-pressure vapor. The cycle then repeats again and again. The heat and work interaction in vapor compression process takes place in following way:

- (i) Compressor requires work ( $W$ ). The work is supplied to the system.
- (ii) During condensation, heat  $Q_H$  the equivalent of latent heat of condensation, etc, is removed from the refrigerant.
- (iii) During evaporation, heat  $Q_L$  equivalent to the latent heat of vaporization is absorbed by the refrigerant.
- (iv) There is no exchange of heat during throttling process through the expansion valve as this process occurs at constant enthalpy.

Figure 8.5 shows a simple vapor compression refrigeration cycle on  $T$ - $S$  diagram for different compression processes. The cycle works between temperatures  $T_1$  and  $T_2$  representing the condenser and evaporator temperatures, respectively. The thermodynamic process of the cycle A-B-C-D is given as:

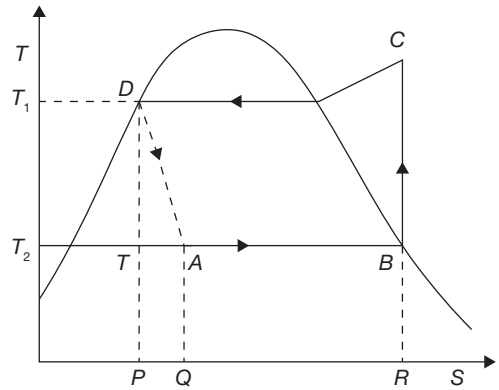
- (i) Process B-C: Isentropic compression of the vapor from state B to C.
- (ii) Process C-D: Heat rejection in condenser is at constant pressure.





**FIGURE 8.4**

Schematic Diagram of Refrigeration Systems



**FIGURE 8.5**

T-S Diagram of Vapor Compression Refrigeration Cycle

- (iii) Process D–A: An irreversible adiabatic expansion of vapor through the expansion valve. The pressure and temperature of the liquid are reduced. The process is accompanied by partial evaporation of some liquid. The process is shown by dotted line.
- (iv) Process A–B: Heat absorption in the evaporator at constant pressure. The final state depends on the quantity of heat absorbed and same may be wet, dry or superheated.

**COP of Vapor Compression Cycle:**

$$\text{COP} = \frac{\text{Heat extracted at low-temperature}}{\text{Work supplied to compressor}}$$

Heat extracted from the system (i.e., absorbed in absorber) = Heat transfer during the process, A–B = refrigerating effect.

$$Q_L = h_B - h_A$$

Work of compression,

$$W = h_C - h_B$$

$$\text{COP} = \frac{h_B - h_A}{h_C - h_B}$$

Heat rejected from condenser,

$$Q_H = W + Q_L = h_C - h_B + h_B - h_A = h_C - h_A = h_C - h_D$$

### *Factors Affecting the Performance of Vapour Compression Refrigeration System*

- (a) **Sub-cooling:** By passing the liquid refrigerant from the condenser through a heat exchanger through, which the cold vapor at suction from the evaporator is allowed to flow in the reversed direction. This process sub-cools the liquid but superheats the vapor. Thus, COP is not improved though refrigeration effect is increased. But, by making use of enough quantity of cooling water so that the liquid refrigerant is further cooled below the temperature of saturation. In some cases, a separate sub cooler is also made use of for this purpose. In this case, COP is improved.
- (b) **Superheating of Vapor:** If the vapor at the compressor entry is in the superheated state, which is produced due to higher heat absorption in the evaporator, then the refrigerating effect is increased. However, COP may increase, decrease or remain unchanged depending upon the range of pressure of the cycle.
- (c) **Change in Suction Pressure:** The decrease in suction pressure decreases the refrigeration effect and at the same time increases the work of compression. But, both the effects tend to decrease the COP.
- (d) **Change in Discharge Pressure:** The increase in discharge pressure results in lower COP. Hence, the discharge pressure should be kept as low as possible depending upon the temperature of the cooling medium available.
- (e) **Effect of Volumetric Efficiency of Compressor:** The factors like clearance volume, pressure drop through discharge and suction valves, leakage of vapor along the piston and superheating of cold vapor due to contact with hot cylinder walls, affects the volume of the vapor actually pumped by the compressor. The volumetric efficiency of a compressor is defined as;

$$\eta_{vol} = \frac{\text{Actual mass of vapor drawn at suction conditions}}{\text{Theoretical mass that can be filled in the displacement volume}}$$

The actual amount of vapor sucked during the suction stroke is  $(V_1 - V_2)$  while the stroke volume is  $(V_1 - V_C)$ . Volumetric efficiency decreases the refrigeration effect.

### *Comparison between Vapour Compression Cycle and Reversed Carnot Cycle*

- ▶ Vapor compression cycle requires more compression work than the Reversed Carnot cycle.
- ▶ No work is done during the throttling process in Vapor compression cycle but work is done in expansion process in Reversed Carnot cycle.
- ▶ In vapor compression expansion process is irreversible whereas in Reversed Carnot cycle it is reversible.

### *Advantages and Disadvantages of Vapour Refrigeration Systems over Air-refrigeration Systems*

#### *Advantages*

- ▶ Vapor refrigeration system has higher COP than the Air refrigeration system.
- ▶ Vapor refrigeration system has easier controllable expansion process.
- ▶ It has low running cost.
- ▶ It requires smaller evaporator.

#### *Disadvantages*

- ▶ Vapor refrigeration system has higher capital cost.
- ▶ In Vapor refrigeration, system leakage problem may occur.

### **8.4.3 Absorption Refrigeration Cycle**

The absorption cycle is a process by which refrigeration effect is produced through the use of two fluids and some quantity of heat input, rather than electrical input as in the more familiar vapor compression cycle. Both vapor compression and absorption refrigeration cycles accomplish the removal of heat through the evaporation of a refrigerant at a low pressure and the rejection of heat through the condensation of the refrigerant at a higher pressure. The method of creating the pressure difference and circulating the refrigerant is the primary difference between the two cycles. The vapor compression cycle employs a mechanical compressor to create the pressure differences necessary to circulate the refrigerant. In the absorption system, a secondary fluid or absorbent is used to circulate the refrigerant. Because the temperature requirements for the cycle fall into the low-to-moderate temperature range, and there is significant potential for electrical energy savings, absorption would seem to be a good prospect for the geothermal application.

Absorption machines are commercially available today in two basic configurations. For applications above 32° F (primarily air conditioning), the cycle uses lithium bromide as the absorbent and water as the refrigerant. For applications below 32° F, an ammonia/water cycle is employed with ammonia as the refrigerant and water as the absorbent.

### **8.5 ► TYPE OF REFRIGERANTS**

Research on the use of refrigerant is continuously going on due to an adverse effect on depletion of ozone layer. The production of many refrigerants will soon end, including R-22 and R-123 in accordance to the requirements of the Montreal Protocol. Suppliers currently offer a range of refrigerants based on chiller type, capacity, and regulatory requirements. The refrigerants can be classified into following classes:

## (a) HaloCarbons

Halocarbon Refrigerants are all synthetically produced and were developed as the Freon family of refrigerants. Some of the refrigerants in this class are given below:

CFCs: R11, R12, R113, R114, R115

HCFCs: R22, R123

HFCs: R134a, R404a, R407C, R410a

## (b) Inorganic Refrigerants

Following refrigerants are used as inorganic refrigerants:

Carbon Dioxide, Water, Ammonia, Air, Sulphur dioxide.

## (c) Zeotropic Refrigerants: A stable mixture of two or several refrigerants whose vapor and liquid phases retain identical compositions over a wide range of temperatures.

## (d) Hydrocarbon Refrigerants

Following hydrocarbon gases have been used as refrigerants in industrial, commercial and domestic applications:

R170, Ethane ( $C_2H_6$ )

R290, Propane ( $C_3H_8$ )

R600, Butane ( $C_4H_{10}$ )

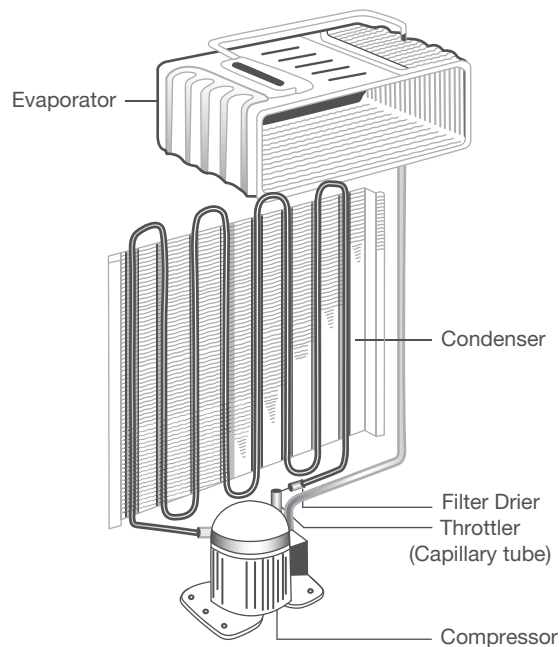
R600a, Isobutane ( $C_4H_{10}$ )

Blends of the above Gases.

## 8.6 ► DOMESTIC REFRIGERATOR

Domestic or household refrigerator is an appliance used for the short term preservation of food products by means of refrigeration. A domestic refrigerator is a metal cabinet with a built-in hermetically sealed refrigerating unit. Inside the cabinet is a cold chamber with shelves for storing products. Heat insulation is placed between the walls of the cold chamber and the case of the refrigerator. The air in the cold chamber is cooled by means of heat transfer between the air and the cold surface of the evaporator. Domestic refrigerators have a storage space of 20 to 800 L. The domestic refrigerator may be of compression type or absorption type, but on these days most of the domestic refrigerators are of compression type. The major parts of the refrigerator that carry out actual working of the refrigerator are discussed in Figure 8.6:

**Refrigerant:** The refrigerant flows through all the internal parts of the refrigerator. It absorbs the heat from the substance to be cooled in the evaporator (chiller or freezer) and throws it to the atmosphere via the condenser. The refrigerant keeps on circulating through all the internal parts of the refrigerator in a cycle.

**FIGURE 8.6**

Major Components of Domestic Refrigerators

**Compressor:** The compressor is located on the back side and in the bottom of the refrigerator. The compressor draws the refrigerant from the evaporator and discharges it at high pressure and temperature. The compressor is driven by the electric motor and it is a major power consuming device of the refrigerator.

**Condenser:** The condenser is a thin coil of copper tubing located at the back of the refrigerator. The refrigerant from the compressor enters the condenser where it is cooled by the atmospheric air thus losing heat absorbed by it in the evaporator and the compressor.

**Expansive valve or the capillary:** The refrigerant leaving the condenser enters into the expansion device, which is the capillary tube in case of the domestic refrigerators. The capillary is the thin copper tubing made up of a number of turns of the copper coil. When the refrigerant is passed through the capillary its pressure and temperature drops down suddenly and then enters the evaporator.

**Evaporator:** Evaporator is a device, which is used to absorb the heat from the atmosphere by means of refrigerant, which gets evaporated. The evaporator is located in the atmosphere of substance, which is to be cooled or chilled. After evaporator, refrigerant again enters into the compressor.

## 8.7 ► PSYCHROMETRY

Psychrometry is the study of air-water vapor mixtures. It is also sometimes referred to as hygrometry. Many mechanical engineering devices exploit psychrometric processes, such as air conditioning systems and cooling towers. Two important principles upon which psychrometric relationships are based are the perfect gas equation and Dalton's law regarding the mixture. The perfect gas equation,  $PV = RT$ , is a fundamental tool used to manipulate the characteristics as one sets out to analyze both definitions and various conditions. Since  $d = 1/v$ , another useful form of the equation is  $p = dRT$ .

**Dalton's Law of Partial Pressure:** Dalton's states that in a mixture of perfect gases, each constituent of the mixture behaves individually as the others are not present. This statement can be expressed as a series of mathematical relationships based on the following logic statements:

- ▶ The total pressure of the mixture is the sum of the individual or partial pressures of the constituents.
- ▶ The mass of the mixture is the sum of the masses of the individual constituents.
- ▶ The temperature of each constituent is equal to the temperature of the mixture.
- ▶ The volume of each of the constituents is equal to the volume of the mixture.
- ▶ The enthalpy of the mixture is the sum of the enthalpies of the individual constituents.

Total pressure of the air-water vapor mixture ( $p_B$ ) can be expressed by Dalton's law equation as the sum of the partial pressures of the constituents;  $p = p_a + p_v$  and if the water vapor is saturated  $p = p_a + p_{vs}$ .

**Relative Humidity ( $\phi$ ):** It is defined as the ratio of partial pressure of water vapor in a mixture and saturated pressure of pure water at the same temperature  $T$ .

$$\phi = \frac{p_v}{p_{vs}} = \frac{m_v}{m_{vs}} = \frac{n_v}{n_{vs}} = \frac{x_v}{x_{vs}}$$

$$= \frac{\text{mass of water vapor in a given vol. of air at temperature } T}{\text{mass of water vapor when the same vol. of air is saturated at temperature } T}$$

**Humidity Ratio or Specific Humidity:** The humidity ( $w$ ) ratio is defined as the mass of water vapor per unit mass of dry air in the mixture of air and water vapor. This term can be

$\omega = \frac{m_v}{m_a} = \frac{d_v}{d_a} = 0.622 [p_v / (p - p_v)]$  and if mixture is saturated  $\omega_s = 0.622 [p_{vs} / (p - p_{vs})]$  as

$$\omega = \frac{m_v}{m_a} = \frac{p_v}{p_a} \cdot \frac{R_a}{R_v} = \frac{p_v}{p - p_v} \cdot \frac{8.3143 / 28.96}{8.3143 / 18} = 0.622 \frac{p_v}{p - p_v}$$

**Degree of Saturation ( $\mu$ ):** It is the ratio of actual specific humidity and the saturated specific humidity, both at the same temperature  $T$ .

$$\mu = \frac{\omega}{\omega_s} = \frac{0.622 [p_v / (p - p_v)]}{0.622 [p_{vs} / (p - p_{vs})]} = \frac{p_v}{p_{vs}} \cdot \frac{(p - p_{vs})}{(p - p_v)}$$

**Dry Bulb Temperature (DBT):** It is the temperature of the mixture as measured by a standard thermometer. The word ‘dry’ is used to imply that the sensor is exposed to the vapor mixture without any liquid present.

**Wet Bulb Temperature (or Saturation Temperature, (WBT):** It is the temperature at which water evaporating into moist air at a given dry-bulb temperature and humidity ratio can bring air to saturation adiabatically at the same pressure.

**Specific Volume ( $v$ ):** It is commonly used, but with units of mixture volume per kilogram of the dry air.

**Dew Point Temperature (DPT):** It is the temperature of moist air saturated at the same pressure and humidity ratio as a given specimen of humid air. If we cool it further, water will start condensing and separates out as fog/dew.

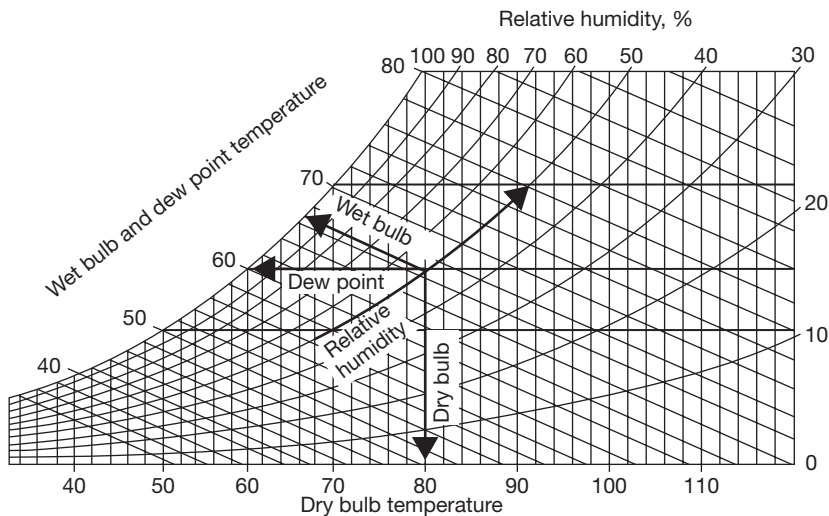
## 8.8 ► PSYCHROMETRIC PROCESSES

### 8.8.1 Psychrometric Chart

A view of psychrometric chart is shown in Figure 8.7. The different psychrometric processes are shown in Figure 8.8.

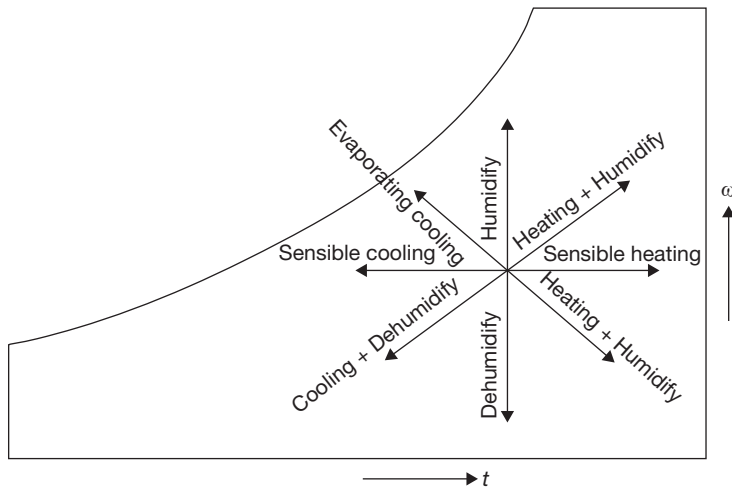
#### *Sensible Cooling*

During this process, the moisture content of air remains constant but its temperature decreases as it passes over a cooling coil. To keep the moisture content constant, the



**FIGURE 8.7**

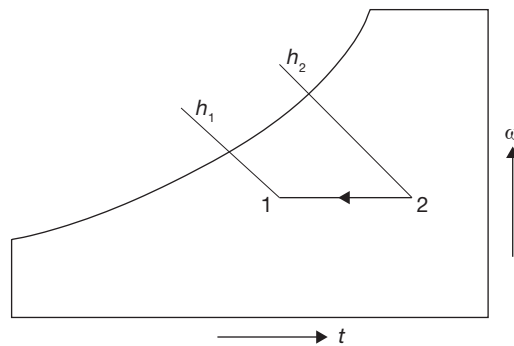
Psychrometric Chart

**FIGURE 8.8**

Psychrometric Processes

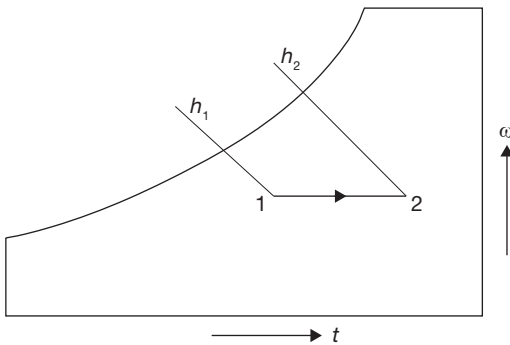
surface of the cooling coil should be dry and its surface temperature should be greater than the dew point temperature of the air. If the cooling coil is 100% effective, then the exit temperature of the air will be equal to the coil temperature. However, in practice, the exit air temperature will be higher than the cooling coil temperature. Figure 8.9 shows the sensible cooling process 2–1 on a psychrometric chart. The heat rejection rate during this process is given by:

$$Q_c = m_a(h_2 - h_1) = m_a c_{pm}(T_2 - T_1)$$

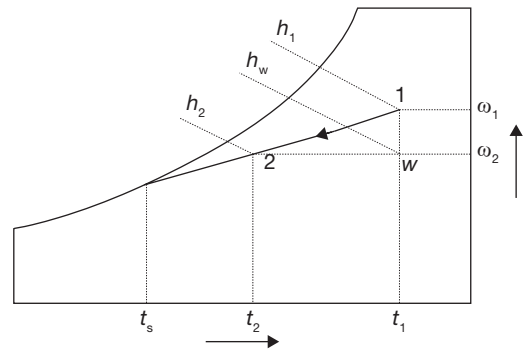
**FIGURE 8.9**

Sensible Cooling Process 2-1 on Psychrometric Chart





**FIGURE 8.10**  
Sensible Heating Process 1-2 on Psychrometric Chart



**FIGURE 8.11**  
Cooling and Dehumidification Process

### Sensible Heating

During this process, the moisture content of air remains constant and its temperature increases as it flows over a heating coil. The heat addition rate during this process is given by:

$$Q_h = m_a(h_2 - h_1) = m_a c_{pm} (T_2 - T_1)$$

where  $c_{pm}$  is the humid specific heat ( $\approx 1.0216 \text{ kJ/kg dry air}$ ) and  $m_a$  is the mass flow rate of dry air ( $\text{kg/s}$ ). Figure 8.10 shows the sensible heating process on a psychrometric chart.

### Cooling and Dehumidification

When moist air is cooled below its dew-point by bringing it in contact with a cold surface, some of the water vapor in the air condenses and leaves the air stream as a liquid, as a result, both the temperature and humidity ratio of air decreases as shown. This is the process air undergoes in an air conditioning system. The actual process path depends on the type of cold surface, the surface temperature, and flow conditions, but for simplicity, the process line is assumed to be a straight line as shown in Figure 8.11. The heat and mass transfer rates can be expressed in terms of the initial and final conditions by applying the conservation of mass and conservation of energy equations as given below:

By applying mass balance for the water:

$$m_a \cdot \omega_a = m_a \cdot \omega_2 + m_w$$

By applying energy balance:

$$m_a \cdot h_a = Q_r + m_w \cdot h_w + m_a \cdot h_2$$

From the above two equations, the load on the cooling coil,  $Q_c$  is given by:

$$Q_c = m_a (h_1 - h_2) - m_a (\omega_1 - \omega_2) h_w$$

The 2<sup>nd</sup> term on the RHS of the above equation is normally small compared to the other terms, so it can be neglected. Hence,

$$Q_r = m_a(h_1 - h_2)$$

It can be observed that the cooling and de-humidification process involves both latent and sensible heat transfer processes, hence, the total, latent and sensible heat transfer rates ( $Q_r$ ,  $Q_l$ , and  $Q_s$ ) can be written as:

$$Q_r = Q_l + Q_s$$

where

$$Q_l = m_a(h_1 - h_w) = m_a \cdot h_{fg}(\omega_1 - \omega_w)$$

and

$$Q_s = m_a(h_w - h_2) = m_a \cdot c_{pm}(T_1 - T_2)$$

### Sensible Heat Factor (SHF)

It is defined as the ratio of sensible to total heat transfer rate ( $Q_t$ ), i.e.,

$$\text{SHF} = Q_s / Q_t = Q_s / (Q_s + Q_l)$$

From the above equation, we can observe that an SHF of 1.0 corresponds to no latent heat transfer and an SHF of 0 corresponds to no sensible heat transfer. An SHF of 0.75 to 0.80 is quite common in air conditioning systems in a normal dry-climate. A lower value of SHF, say 0.6, implies a high latent heat load such as that occurs in a humid climate.

The temperature,  $T_s$ , is the effective surface temperature of the cooling coil and is known as apparatus dew-point (ADP) temperature. In an ideal situation, when all the air comes in perfect contact with the cooling coil surface, then the exit temperature of the air will be same as ADP of the coil. However, in the actual case, the exit temperature of the air will always be greater than the apparatus dew-point temperature due to boundary layer development as air flows over the cooling coil surface and also due to temperature variation along the fins, etc. Hence, we can define a *by-pass factor (BPF)* as it can be easily seen that higher the by-pass factor larger will be the difference between air outlet temperature and the cooling coil temperature. When BPF is 1.0, all the air bypasses the coil and there will not be any cooling or de-humidification.

$$\text{BPF} = \frac{T_c - T_s}{T_a - T_s}; \text{ CF (Contact Factor) } = 1 - \text{BPF}$$

Where  $T_c$  temperature of air leaving,  $T_a$  is temperature of air entering and  $T_s$  is temperature of surface of cooling coil.

### Heating and Humidification

During winter it is essential to heat and humidity the room air for comfort. As shown in Figure 8.11, this is normally done by first sensible heating the air and then adding water vapor to the air stream through steam nozzles as shown in Figure 8.12.

Mass balance of water vapor for the control volume yields the rate, at which steam has to be added, i.e.,  $m_w$ :

$$m_w = m_a(\omega_2 - \omega_1)$$

where  $m_a$  is the mass flow rate of dry air. From energy balance:

$$Q_h = m_a(h_2 - h_1) - m_w h_w$$

where  $Q_h$  is the heat supplied through the heating coil and  $h_w$  is the enthalpy of steam. Since this process also involves simultaneous heat and mass transfer, we can define a sensible heat factor for the process in a way similar to that of a cooling and dehumidification process.

### Cooling and Humidification

As the name implies, during this process, the air temperature drops and its humidity increases. As shown in Figure 8.13, this can be achieved by spraying cool water in the air stream. The temperature of the water should be lower than the dry-bulb temperature of air but higher than its dew-point temperature to avoid condensation ( $T_{DPT} < T_2 < T_1$ ).

During this process, there is sensible heat transfer from air to water and latent heat transfer from water to air. Hence, the total heat transfer depends upon the water temperature. If the temperature of the water sprayed is equal to the wet-bulb temperature of the air, then the net transfer rate will be zero as the sensible heat transfer from air to water will be equal to latent heat transfer from water to air. If the water temperature is greater than WBT, then there will be a net heat transfer from water to air. If the water temperature is less than WBT, then the net heat transfer will be from air to water. Under a special case when the spray water is entirely recirculated and is neither heated nor cooled, the system is perfectly insulated and the make-up water is supplied at WBT, then at steady-state, the air undergoes an adiabatic saturation process, during which its WBT remains

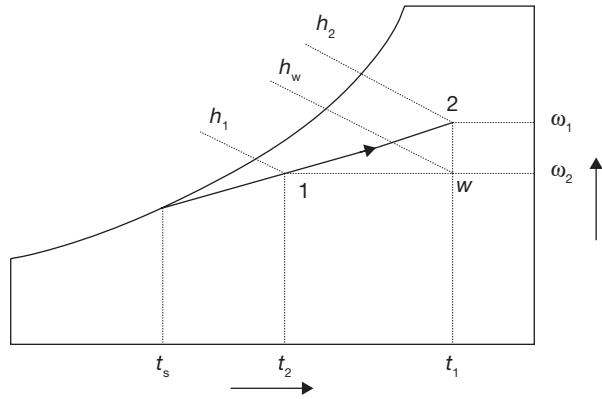


FIGURE 8.12

Heating and Humidification Process

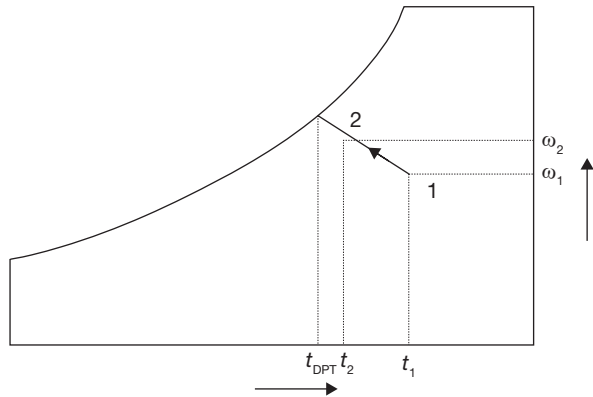


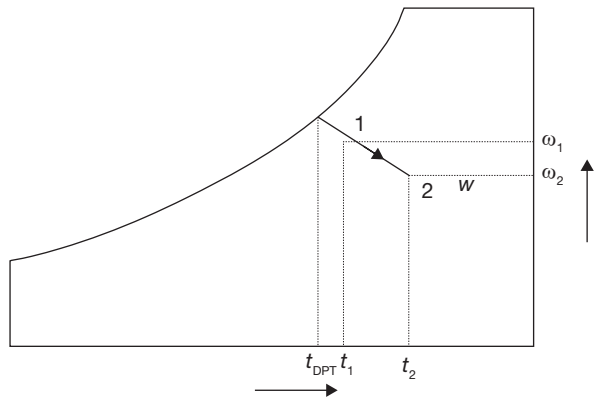
FIGURE 8.13

Cooling and Humidification Process

constant. This is the process of adiabatic saturation. The process of cooling and humidification is encountered in a wide variety of devices such as evaporative coolers, cooling towers, etc.

### Heating and Dehumidification

This process can be achieved by using a hygroscopic material, which absorbs or adsorbs the water vapor from the moisture. If this process is thermally isolated, then the enthalpy of air remains constant, as a result, the temperature of air increases as its moisture content decreases as shown in Figure 8.14. This hygroscopic material can be a solid or a liquid. In general, the absorption of water by the hygroscopic material is an exothermic reaction, as a result heat is released during this process, which is transferred to air and the enthalpy of air increases.



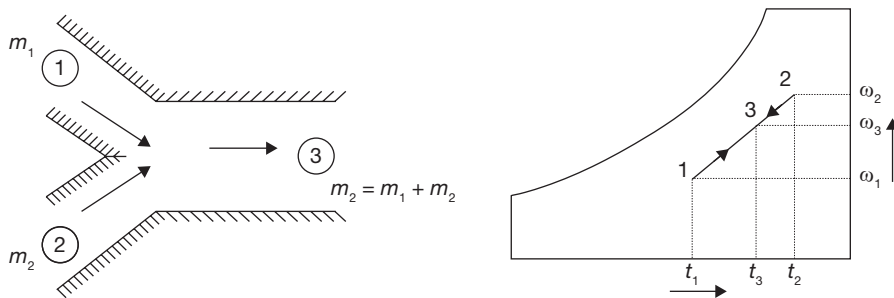
**FIGURE 8.14**

Heating Dehumidification Process

### Mixing of Air Streams

Mixing of air streams at different states is commonly encountered in many processes, including in air conditioning. Depending upon the state of the individual streams, the mixing process can take place with or without condensation of moisture.

- (i) Without condensation: Figure 8.15 shows an adiabatic mixing of two moist air streams during which no condensation of moisture takes place. When two air streams at state points 1 and 2 mix, the resulting mixture condition 3 can be obtained from mass and energy balance.



**FIGURE 8.15**

Mixing of Two Air Streams without Condensation

From the mass balance of dry air and water vapor:

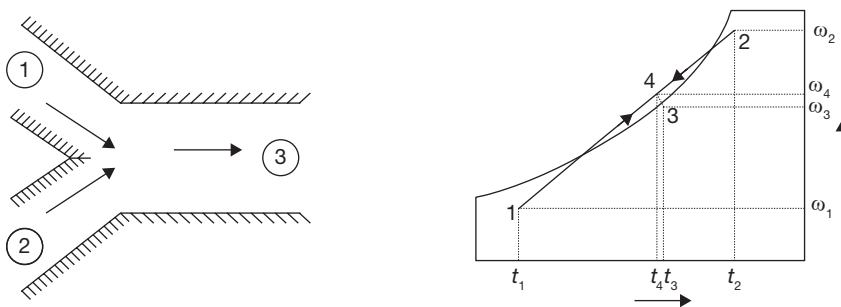
$$m_{a1}\omega_1 + m_{a2}\omega_2 = (m_{a1} + m_{a2})\omega_3$$

From energy balance:

$$m_{a1}h_1 + m_{a2}h_2 = (m_{a1} + m_{a2})h_3$$

From the above equations, it can be observed that the final enthalpy and the humidity ratio of mixture are weighted averages of inlet enthalpies and humidity ratios. A generally valid approximation is that the final temperature of the mixture is the weighted average of the inlet temperatures. With this approximation, the point on the psychrometric chart representing the mixture lies on a straight line connecting the two inlet states. Hence, the ratio of distances on the line, i.e., (1-3)/(2-3) is equal to the ratio of flow rates  $m_{a2}/m_{a1}$ . The resulting error (due to the assumption that the humid specific heats being constant) is usually less than 1%.

- (ii) Mixing with condensation: As shown in Figure 8.16, when very cold and dry air mixes with warm air at high relative humidity, the resulting mixture condition may lie in the two-phase region, as a result, there will be condensation of water vapor and some amount of water will leave the system as liquid water. Due to this, the humidity ratio of the resulting mixture (point 3) will be less than that at point 4. Corresponding to this will be an increase in temperature of air due to the release of latent heat of condensation. This process rarely occurs in an air conditioning system, but this is the phenomenon which results in the formation of fog or frost (if the mixture temperature is below 0°C). This happens in winter when the cold air near the earth mixes with the humid and warm air, which develops towards the evening or after rains.



**FIGURE 8.16**

Mixing of Two Air Streams with Condensation

**EXAMPLE 8.3**

A glass of water is mixed with ice. The moisture from the air begins to condense on the surface of glass when the temperature of water comes 10°C. If the room temperature and pressure are 20°C and 1.01325 bar, Determine the partial pressure and mass of water vapor in grams per kg of dry air.

**SOLUTION**

From steam table:

Partial pressure of water vapor at 10°C,  $p_v = 0.01 \text{ bar}$

Partial pressure of dry air,  $p_a = p_{\text{atm.}} - p_v = 1.013 - 0.012 = 1 \text{ bar}$

Specific humidity,  $\omega = 0.622 \frac{p_v}{p_a} = 0.622 \frac{0.01}{1} = 0.00622 \text{ kg/kg of dry air} = 6.22 \text{ g/kg dry air}$

Mass of water vapor in mixture is given by,  $\frac{m_v}{m_{\text{mix}}} = \frac{\omega}{1 + \omega} = \frac{0.006222}{1 + 0.00622} = 6.18 \text{ g/kg of mixture}$

**EXAMPLE 8.4**

The pressure and temperature of the mixture of air and water vapor at 1 bar and 20°C. The dew point temperature of the mixture is 14°C. Find partial pressure of water vapor the in mixture, relative humidity, specific humidity, enthalpy of mixture per kg of dry air, and specific Volume of mixture per kg of dry air.

**SOLUTION**

From Steam Table:

At 14°C, vapor pressure of moisture,  $p_v = 0.015983 \text{ bar}$

At 20°C, saturation pressure,  $p_{vs} = 0.02339 \text{ bar}$

Relative humidity,  $\phi = \frac{p_v}{p_{vs}} = \frac{0.015983 \text{ bar}}{0.02339 \text{ bar}} = 68.33\%$

Specific humidity,  $\omega = 0.622 \frac{p_v}{p_{\text{atm}} - p_v} = 0.622 \frac{0.0159 \text{ bar}}{1.0132 \text{ bar} - 0.0159 \text{ bar}} = 0.00991 \text{ kg/kg of dry air}$   
**= 9.91 gm/kg of dry air**

Enthalpy of water vapor,  $h_s = c_p \times \text{DBT} + h_{fg} = 4.18 \text{ kJ/kgK} \times 20^\circ \text{C} + 2454.1 \text{ kJ/kg}$  (from steam table)  
**= 2537.7 kJ / kg**

Enthalpy of mixture per kg of dry air,  $h_{\text{mix}} = h_a + \omega \times h_s$   
**= 1 × 20° C + 0.0099 kg/kg of dry air × 2537.7 kJ / kg**  
**= 45.12 kJ/kg of dry air**

Specific volume of mixture is equal to the volume of 1 kg of dry air,  $v_a = \frac{R_a T}{P_a}$

$$= \frac{287 \text{ J/kgK} \times (20^\circ \text{C} + 273)}{(1.0132 - 0.0159) \times 10^5 P_a}$$

$$= 0.843 \text{ m}^3/\text{kg of dry air.}$$

**EXAMPLE 8.5**

50 m<sup>3</sup> of air at 20°C DBT and 15°C WBT are mixed with 20 m<sup>3</sup> of dry air at 30°C DBT and 20°C WBT. Determine the DBT and WBT of the mixture.

**SOLUTION**

From psychrometric chart, at 20°C DBT and 15°C WBT, the psychrometric property values can be given as:

$$V_{a1} \text{ (Sp. Vol.)} = 0.8412 \text{ m}^3/\text{kg}$$

$$\omega_1 = 0.00875 \text{ kg/kg of dry air,}$$

$$h_1 = 42.34 \text{ kJ/kg}$$

$$m_1 = 50/0.8412 = 59.43 \text{ kg of dry air}$$

Similarly,

From the psychrometric chart, at 30°C DBT and 20°C WBT, the psychrometric property values can be given as:

$$V_{a2} \text{ (Sp. Vol.)} = 0.8699 \text{ m}^3/\text{kg}$$

$$\omega_2 = 0.01076 \text{ kg/kg of dry air,}$$

$$h_2 = 57.71 \text{ kJ/kg}$$

$$m_2 = 20/0.8699 = 22.99 \text{ kg of dry air}$$

$$\omega_3 = \frac{m_1 \omega_1 + m_2 \omega_2}{m_1 + m_2} = \frac{59.43 \text{ kg} \times 0.00875 \text{ kg/kg of dry air} + 22.99 \text{ kg} \times 0.01076 \text{ kg/kg of dry air}}{59.43 \text{ kg} + 22.99 \text{ kg}}$$

$$= 0.00931 \text{ kg/kg of dry air}$$

$$h_3 = \frac{m_1 h_1 + m_2 h_2}{m_1 + m_2} = \frac{59.43 \text{ kg} \times 42.34 \text{ kJ/kg} + 22.99 \text{ kg} \times 57.71 \text{ kJ/kg}}{59.43 \text{ kg} + 22.99 \text{ kg}} = 46.627 \text{ kJ/kg}$$

(Use Psychrometric chart to find DBT and WBT at the mixture's final specific humidity and enthalpy.)

**EXAMPLE 8.6**

The DBT and RH of air are 40°C and 70%, respectively. The atmospheric pressure is 1 bar. Determine the specific humidity and vapor pressure of moisture in the air. If 8 grams of water vapor is removed from the air and temperature is reduced to 30°C. Find the relative humidity and DPT.

**SOLUTION**

$$\text{Relative humidity, } \phi = \frac{p_v}{p_{vs}} \Rightarrow 0.7 = \frac{p_v}{0.07384 \text{ (at } 40^\circ\text{C from steam table)}}$$

$$p_v = 0.0516 \text{ bar}$$

$$\text{Specific humidity, } \omega = 0.622 \frac{p_v}{p_{atm} - p_v} = 0.622 \frac{0.0516 \text{ bar}}{1 \text{ bar} - 0.0516 \text{ bar}}$$

$$= 0.03384 \text{ kg/kg} = 33.84 \text{ gm/kg}$$

If 8 grams of water are removed from air,  $\omega = 33.84 - 8 = 25.84 \text{ gram/kg}$

$$0.02584 = 0.622 \frac{p_v}{1 - p_v} \Rightarrow p_v = 0.0398 \text{ bar}$$

$$\text{Relative humidity, } \phi = \frac{p_v}{p_{vs}} = \frac{0.0398 \text{ bar}}{0.04246 \text{ bar (from steam table, at } 30^\circ\text{C)}}$$

$$= \mathbf{0.938}$$

**EXAMPLE 8.7**

100 m<sup>3</sup> of air per minute at 30°C and 60% is cooled to 22°C DBT (sensible cooling). Find the heat removed from the air, relative humidity of the cooled air, WBT of cooled air (Take air pressure = 1 bar).

**SOLUTION**

From steam table, at 30°C DBT,  $p_{vs1} = 0.0425 \text{ bar}$

$$\text{Relative humidity, } \phi_1 = \frac{p_{v1}}{p_{vs1}} \Rightarrow 0.6 = \frac{p_{v1}}{0.0425}; p_{v1} = 0.6 \times 0.0425 = 0.0255 \text{ bar}$$

$$\text{Specific humidity, } \omega_1 = 0.622 \frac{p_{v1}}{p_{atm} - p_{v1}} = 0.622 \times \frac{0.0255 \text{ bar}}{1 \text{ bar} - 0.0255 \text{ bar}} = 0.0154 \text{ kg/kg of dry air}$$



$$\begin{aligned} \text{Enthalpy of water vapor mixture, } h_1 &= C_{pa} \cdot \text{DBT} + \omega (C_{pw} \cdot \text{DBT} + h_{fg}) \\ h_1 &= 1.005 \text{ kJ/kgK} \times 30^\circ\text{C} + 0.0154 \\ &\quad (1.88 \text{ kJ/kgK} \times 30^\circ\text{C} + 2430.5 \text{ kJ/kg}) \\ &= 68.44 \text{ kJ/kg} \end{aligned}$$

$$\text{At } 22^\circ\text{C DBT,} \quad \omega_2 = \omega_1 = 0.0154 \text{ kg/kg of dry air}$$

$$\text{Relative humidity, } \phi_2 = \frac{p_{v2}}{p_{vs2}} = \frac{0.0255 \text{ bar}}{0.0265 \text{ (from steam table, at } 22^\circ\text{C DBT) bar}} = \mathbf{96.25\%}$$

$$\begin{aligned} \text{Enthalpy of water vapor mixture, } h_2 &= C_{pa} \cdot \text{DBT} + \omega (C_{pw} \cdot \text{DBT} + h_{fg}) \\ h_2 &= 1.005 \text{ kJ/kgK} \times 22^\circ\text{C} + 0.0154 \\ &\quad (1.88 \text{ kJ/kgK} \times 22 + 2449.5 \text{ kJ/kg}) \\ &= 60.48 \text{ kJ/kg} \\ m_a &= \frac{p_{a1} V_{a1}}{RT_1} = \frac{(1 \text{ bar} - 0.0255 \text{ bar}) \times 10^5 \times 100 \text{ m}^3}{287 \text{ J/kgK} \times 303 \text{ K}} = 260 \text{ kg/min.} \\ \text{Heat removed, } Q &= m_a (h_1 - h_2) = 260 \text{ kg} (68.44 \text{ kJ/kg} - 60.48 \text{ kJ/kg}) \\ &= \mathbf{2069.6 \text{ kJ/min.}} \end{aligned}$$

## 8.9 ► AIR WASHERS

An air washer is a device for conditioning air. As shown in Figure 8.17, in an air washer air comes in direct contact with a spray of water and there will be an exchange of heat and mass (water vapor) between air and water. The outlet condition of air depends upon the temperature of water sprayed in the air washer. Hence, by controlling the water temperature externally, it is possible to control the outlet conditions of air, which then can be used for air conditioning purposes.

## 8.10 ► HUMAN COMFORT CONDITIONS

Air conditioning is the process whereby the condition of air, as defined by its temperature and moisture content, is changed as per requirement. In practice, other factors should also be taken into account especially cleanliness; odor, velocity, and distribution pattern. Comfort is a very subjective matter. The Engineer aims to ensure comfort for most people found from statistical surveys. Most people (90%) are comfortable when the air temperature is between 18–22°C and the % saturation is between 40–65%.

There are following general conditions required for human comfort

- Supply of oxygen per person should always be more than 0.65 m<sup>3</sup> per person per hour.
- The amount of carbon dioxide should not be more than 2% in the air.

- (c) The temperature range may vary from 22°C to 26°C.
- (d) Humidity range may vary from 60% to 70%.

## 8.11 ► ROOM AIR CONDITIONER

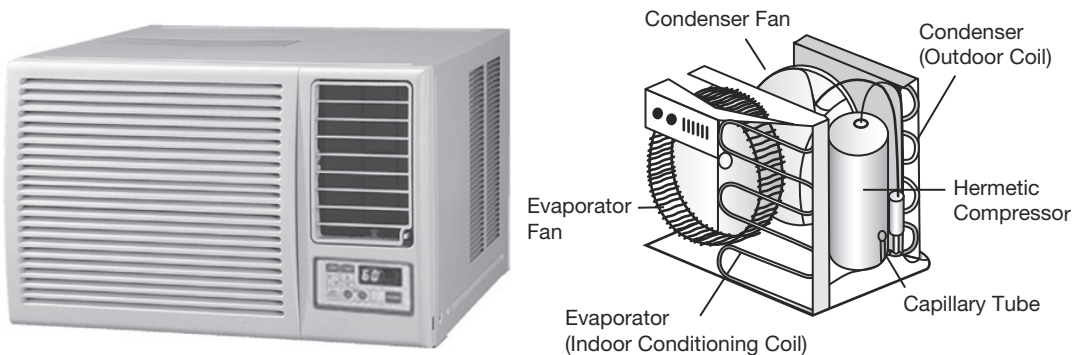
Generally, two main types of room air conditioners are used; one is a window air conditioner and another is a split air conditioner. The details of the working of these air conditioners are discussed below:

### 8.11.1 Window Air Conditioner

The most common air conditioner, which is used for small houses and offices, is window air conditioner as shown in Figure 8.17. It is a cubical unit, a complete conditioning system in itself; it requires a window, or such space, where it can be installed with its face inside the room, and the exterior part outside the room, as it discharges heat outside. It is very easy to install. As compressor and evaporator, both are in one unit, so its cooling capacity is limited, this makes it suitable only for small places. The main components of a window AC are Compressor, Expansion valve, Hot condenser coil (exterior) Cold evaporator coil (interior) Two fans Control unit.

#### Front Panel

The front panel is that part of the window unit, which is seen inside from the room by the user. It has a user interface controlled either manually or through remote control. The older unit usually is of mechanical control type with rotary knobs to control the temperature



**FIGURE 8.17**

Window Air Conditioner and its Components

and fan speed of the air conditioner. The newer units come with electronic control system where the functions are controlled using remote control and touch panel with digital display. The front panel has adjustable horizontal and vertical louvers to adjust the direction of air flow as per the desire of the user. The fresh intake of air called VENT (ventilation) is provided at the panel in the event that user would like to have a certain amount of fresh air from the outside.

### ***Indoor Side Components***

The inside parts include:

- ▶ *Cooling Coil* with an air filter mounted on it. The cooling coil is where the heat exchange takes place between the refrigerant in the system and the air in the room.
- ▶ *Fan Blower* is a centrifugal evaporator blower to discharge the cool air to the room.
- ▶ *Capillary Tube* is used as an expansion device. It can be noisy while operating if it is installed too close to the evaporator.
- ▶ *Operation Panel* is used to control the temperature and the speed of the blower fan. A thermostat is used to sense the return air temperature and another one to monitor the temperature of the coil.
- ▶ *Filter Drier* is used to remove the moisture from the refrigerant.
- ▶ *Drain Pan* is used to collect the water that condensate from the cooling coil and is discharged out to the outdoor by gravity.

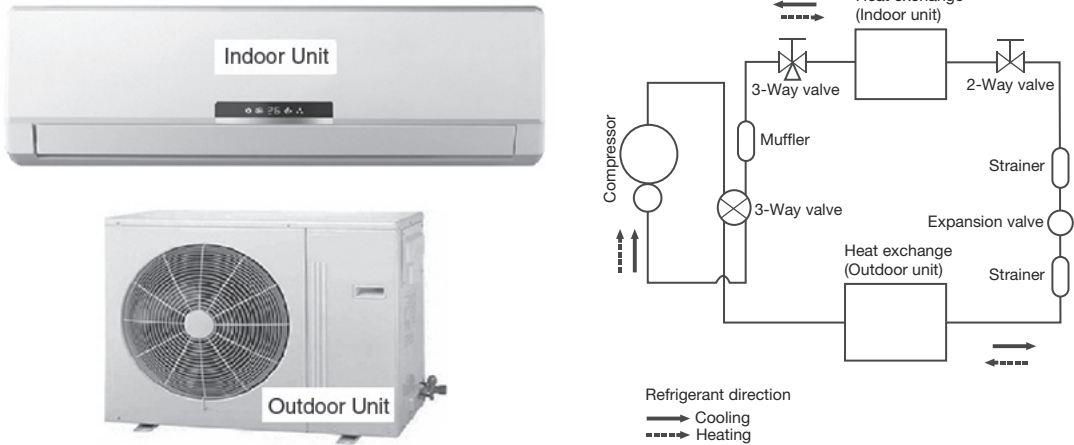
### ***Outdoor Side Components***

The outdoor side parts include:

- ▶ *Compressor* is used to compress the refrigerant.
- ▶ *Condenser Coil* is used to reject heat from the refrigerant to the outside air.
- ▶ *Propeller Fan* is used in the air-cooled condenser to help move the air molecules over the surface of the condensing coil.
- ▶ *Fan Motor* is located here. It has a double shaft where the indoor blower and outdoor propeller fan are connected together.

## **8.11.2 Split Air Conditioner**

The split air conditioner comprises of two parts: the outdoor unit and the indoor unit (Figure 8.18). The outdoor unit consists of components like the compressor, condenser, and expansion valve fitted outside the room and the indoor unit consists of the evaporator or cooling coil and the cooling fan fitted inside the room. Split units have aesthetic looks and add to the beauty of the room. The split air conditioner can be used to cool one or two rooms.

**FIGURE 8.18**

Split Air Conditioner and Its Working Line Diagram

Since the compressor and condenser unit can be installed outside the room, inside the air conditioner feels calm and quiet. Split AC is an excellent option for office use and for large commercial buildings. Due to its compact size split AC is becoming popular even for household usage.

### 8.11.3 Difference Between Split and Window ACs

The working principle of both window AC and split AC are same, both but as they have different capacities, so both are used for different places. Split AC, being divided into two parts, has a large capacity, so it's ideal for use in large offices and big rooms in the house. On the other hand, window AC is one unit conditioner, so it's suitable for small rooms only. Window AC creates noise, whereas Split unit is found to be calm. Window AC is smaller in size as compared to split AC. Window AC is easy to install, but in the case of split AC, the exterior unit is to be connected to the interior unit through rubber tubes, which might cause troubles. Moreover, a window is necessary if you want to install window AC in your room, but for split AC, the interior unit will be connected to compressor unit through a small hole in the wall.



## RECAP ZONE .....

### Points to Remember

- The **refrigeration unit** transfers heat from cold to hot regions for the purpose of cooling the cold region while the **heat pump** does the same thing with the intent of heating the hot region.
- There are five basic components of a refrigeration system, these are: Evaporator, Compressor, Condenser, and Expansion Valve.
- The purpose of the **evaporator** is to remove unwanted heat from the product, via the liquid refrigerant.
- The purpose of the **compressor** is to draw the low-temperature, low-pressure vapor from the evaporator via the suction line. Once drawn, the vapor is compressed.
- The purpose of the **condenser** is to extract heat from the refrigerant to the outside air.
- Within the refrigeration system, the expansion valve is located at the end of the liquid line, before the evaporator.
- By passing the liquid refrigerant from the condenser through a heat exchanger through which the cold vapor at suction from the evaporator is allowed to flow in the reversed direction. This process subcools the liquid but superheats the vapor.
- If the vapor at the compressor entry is in the superheated state which is produced due to higher heat absorption in the evaporator, then the refrigerating effect is increased.
- The decrease in suction pressure decreases the refrigeration effect and at the same time increases the work of compression.
- The increase in discharge pressure results in lower COP.
- The factors like clearance volume, the pressure drop through discharge and suction valves, leakage of vapor along the piston and superheating of cold vapor due to contact with hot cylinder walls, affects the volume of the vapor actually pumped by the compressor.
- Generally, two main types of room air conditioners are used; one is a window air conditioner and another is split air conditioner.

### Important Formulae

1. Coefficient of performance: 
$$COP_R = \frac{\text{Desired output}}{\text{Required input}} = \frac{\text{Cooling effect}}{\text{Work input}} = \frac{Q_L}{W_{in}}$$

$$COP_{HP} = \frac{\text{Desired output}}{\text{Required input}} = \frac{\text{Heating effect}}{\text{Work input}} = \frac{Q_H}{W_{in}}$$

$$COP_{HP} = COP_R + 1$$
2. Tonnes of refrigeration:  $TR = Q \times C_p \times (T_i - T_o) / 3024 = 210 \text{ kJ/min or } 3.5 \text{ kJ/s}$
3. COP of refrigerator: 
$$COP = \frac{\text{Heat absorbed}}{\text{Work supplied}} = \frac{\text{Heat absorbed}}{\text{Heat rejected} - \text{Heat absorbed}} = \frac{T_L}{T_H - T_L}$$
4. Volumetric efficiency of compressor: 
$$\eta_{vol} = \frac{\text{Actual mass of vapor drawn at suction conditions}}{\text{Theoretical mass that can be filled in the displacement volume}}$$
5. Saturation pressure at DPT =  $P_v$

6.	Saturation pressure at $DBT + P_{vs}$
7.	Partial pressure of air, $P_a = P_{atm} - P_v$
8.	Humidity ratio or specific humidity, $\omega = 0.622 \frac{P_v}{P_a}$
9.	Saturation pressure at $DBT = P_{vs}$
10.	Relative humidity, $\phi = \frac{P_v}{P_{vs}}$
11.	Mass of water vapor in mixture = $\frac{\omega}{1+\omega}$
12.	Enthalpy of water vapor mixture = $C_{pa} \cdot DBT + \omega(C_{pw} \cdot DBT + h_{fg})$
13.	If DPT is not given and only WBT and DBT are given then $P_v$ can be calculated from Carrier's equation as: $P_v = (P_{vs})_{WBT} - \frac{[P_a - (P_{vs})_{WBT}][(DBT - WBT) * 1.8]}{[2800 - 1.3(1.8 * DBT + 32)]}$
14.	Density of water vapor mixture = $\rho_a + \rho_v = \frac{P_a}{R_a T} + \frac{P_v}{R_v T}$ ; where $R_a = 287 \text{ kJ/kg}$ and $R_v = 461 \text{ kJ/kg}$
15.	Enthalpy per kg of air = $\frac{h}{1+\omega}$

## REVIEW ZONE .....



### Multiple-choice Questions

- The cooling effect in refrigeration is obtained by:
  - Mechanical refrigeration technique
  - Passing a direct current through the junction of two dissimilar metals
  - Sublimation of carbon dioxide
  - Throttling of a real gas
 Which of the above statements are correct?
  - (i) and (ii)
  - (i), (ii) and (iii)
  - (i), (ii) and (iv)
  - (i), (ii), (iii) and (iv)
- The cooling effect produced by refrigeration finds application in:
  - Construction of cold storages
  - Cooling of concrete in dams
  - Comfort air conditioning of hospitals
  - Liquidation of gases and vapors
 Select your answer from the following codes:
  - (i) and (iii)
  - (i), (ii) and (iii)
  - (i), (iii) and (iv)
  - (i), (ii), (iii) and (iv)
- A refrigeration system:
  - Removes heat from a system at low-temperature and transfers the same to a system at high-temperature
  - Delivers less heat to the system at high-temperature than it extracts from the system at low-temperature
  - Transfers heat from a high-temperature source to a low-temperature sink
  - Violates second law of thermodynamics
- The COP of a Carnot refrigeration cycle decreases on:
  - Decreasing the difference in operating temperatures
  - Keeping the upper-temperature constant and increasing the lower-temperature
  - Increasing the upper-temperature and keeping the lower-temperature constant
  - Increasing the upper-temperature and decreasing the lower-temperature
- A Carnot refrigerating cycle used in house air conditioning delivers heat to the surroundings at the rate of 10 kw of power. The coefficient of performance of this refrigerator would be:
  - 1.5
  - 1.67
  - 2.5
  - 0.6

6. If a Carnot cycle is to have a coefficient of performance of 5, the ratio of maximum temperature to minimum temperature in the cycle should be:  
 (a) 1.2 (b) 1.5  
 (c) 2.0 (d) 2.5
7. A Carnot refrigerator rejects 3000 kJ of heat at 400 K while using 1000 kJ of work. The lowest operating temperature in the cycle should be:  
 (a) 15° C (b) 27° C  
 (c) -6° C (d) 0° C
8. A Carnot engine has an efficiency of 80%. If the cycle is reversed in direction and made to operate as a refrigerator, its COP will be:  
 (a) 0.25 (b) 0.5  
 (c) 0.75 (d) 1.25
9. A condenser of a refrigeration system rejects heat at a rate of 120 kW, while its compressor consumes a power of 30 kW. The coefficient of performance of the system would be:  
 (a) 2 (b) 3  
 (c) 4 (d) 5
10. The operating temperature of cold storage is 280° K and the heat leakage from the surroundings is 35 kW for the ambient temperature of 310° K. If the actual COP of the refrigeration plant is one-fourth of an ideal plant working between the same temperature limits, the power required to drive the plant would be:  
 (a) 3.7 kW (b) 7.5 kW  
 (c) 12 kW (d) 15 kW
11. A Carnot heat pump for domestic heating works between a cold system (the contents of refrigerator cabinet) at 0° C and the water in the radiator system at 80° C. The coefficient of performance of this heat pump would be about:  
 (a) 1.4 (b) 3.4  
 (c) 4.4 (d) 6.2
12. A heat pump working on a reversed Carnot cycle has a COP of 5. If it is made to work as a refrigerator taking 1 kW of work input, the refrigerating effect will be:  
 (a) 1 kW (b) 2 kW  
 (c) 3 kW (d) 4 kW
13. The capacity of refrigerating m/c is expressed as:  
 (a) Inside volume of cabinet  
 (b) Lowest temperature attained  
 (c) Gross weight of m/c in tons  
 (d) Rate of abstraction of heat from the space being cooled
14. One TOR implies that the m/c has a refrigerating effect (capacity of heat extraction from the system being cooled) equal to:  
 (a) 50 kCal/sec (b) 50 kCal/min  
 (c) 50 kCal/hr (d) 50 kCal/day
15. One TOR is equivalent to:  
 (a) 1 kW (b) 2.5 kW  
 (c) 3.5 kW (d) 5 kW
16. The domestic refrigerator has a refrigerating load of the order of:  
 (a) Less than 0.25 ton  
 (b) Between 0.5 and 1 ton  
 (c) More than 1 ton  
 (d) More than 5 ton
17. The refrigerating capacity of 165 domestic refrigerators is approximately equal to:  
 (a) 0.05 ton (b) 0.1 ton  
 (c) 2 ton (d) 5 ton
18. Round the clock cooling of an apartment having a load of 300 MJ/day requires an air conditioning plant of capacity about:  
 (a) 1 ton (b) 5 ton  
 (c) 10 tons (d) 25 tons
19. The refrigerating system of passenger air craft works on reversed:  
 (a) Brayton cycle (b) Atkinson cycle  
 (c) Ericsson cycle (d) Carnot cycle
20. A Bell-Coleman cycle is a reversed:  
 (a) Brayton cycle (b) Atkinson cycle  
 (c) Ericsson cycle (d) Carnot cycle
21. The Bell-Coleman refrigeration cycle uses \_\_\_\_\_ as working fluid.  
 (a) Hydrogen (b) Carbon dioxide  
 (c) Air (d) Any inert gas

## Answers

- |         |         |         |         |         |         |
|---------|---------|---------|---------|---------|---------|
| 1. (d)  | 2. (d)  | 3. (a)  | 4. (d)  | 5. (a)  | 6. (a)  |
| 7. (b)  | 8. (a)  | 9. (c)  | 10. (d) | 11. (c) | 12. (d) |
| 13. (d) | 14. (b) | 15. (c) | 16. (a) | 17. (b) | 18. (a) |
| 19. (a) | 20. (d) | 21. (c) |         |         |         |

## Theory Questions

1. Differentiate the working of refrigeration and heat pump, thermodynamically.
2. Enumerate the various components used in a refrigerator and explain their working.
3. Write advantages and disadvantages of air refrigeration cycle.
4. Find the expression for COP using Reversed Carnot cycle and Bell Coleman cycle.
5. Find the derivation for COP in Vapor Compression cycle.
6. Explain the effect of subcooling and superheating on COP of Vapor Compression Cycle.
7. Compare vapor compression and Reversed Carnot Cycle.
8. Write advantages and disadvantages of Vapor Compression Cycle over Air Refrigeration Cycle.
- \*9. Explain the working of vapor absorption cycle.
10. What do you mean by sensible heating and sensible cooling?
11. What do you mean by latent heating and latent cooling?
12. Write notes on bypass factor and sensible heat factor.
13. What are the human comfort conditions?
14. What are the various types of refrigerators have been in the application? Explain them.
15. Explain the various refrigerants used in refrigeration and air conditioning.
16. Write short notes on Window Air Conditioner and Split Air Conditioner.
- \*17. Differentiate between refrigeration and air conditioning, vapor compression refrigeration and vapor absorption refrigeration. With a neat sketch, explain the working of a room air conditioner.
- \*18. Define the following: (i) COP, (ii) unit of refrigeration, and (iii) air conditioning.
- \*19. Explain with neat sketch the principle and construction of vapor absorption refrigeration system.
- \*20. What is refrigeration? What is refrigeration effect? Explain window air conditioner with neat sketch.
- \*21. Explain with a neat sketch the working of a vapor compression refrigerator. Also draw p-h and T-s diagram for the same.
- \*22. Define air-conditioning. Classify the air conditioning system in detail.
- \*23. Define:
  - (i) Sensible heat
  - (ii) Latent heat
  - (iii) Dryness Fraction
  - (iv) Enthalpy of evaporation
- \*24. What should be the properties of common refrigerants?
- \*25. Define air conditioning. State the basic component of air conditioning systems.
- \*26. Sketch and explain split air conditioner?
- \*27. Discuss about psychrometry and their properties?
- \*28. Explain the working of domestic refrigeration system with a neat sketch?
- \*29. Name any six properties of refrigerants.
- \*30. Distinguish between a heat engine, a heat pump, and a refrigerator.
- \*31. With a neat sketch of a room air-conditioner, explain its working principle.

\* indicates that similar questions have appeared in various university examinations.



## Numerical Problems

1. Carnot refrigeration cycle absorbs heat at 280 K and rejects heat at 310 K.
  - (a) Calculate the coefficient of performance of this refrigeration cycle.
  - (b) If the cycle is absorbing 1120 kJ/min at 280 K, how many kJ of work is required per second?
  - (c) If the Carnot heat pump operates between the same temperatures as the above refrigeration cycle, what is the coefficient of performance?
  - (d) How many kJ/min will the heat pump deliver at 310 K if it absorbs 1120 kJ/min at 280 K.
2. The capacity of a refrigerator is 200 TR when working between  $-4^{\circ}\text{C}$  and  $22^{\circ}\text{C}$ . Determine the mass of ice produced per day from water at  $22^{\circ}\text{C}$ . Also, find the power required to drive the unit. Assume that the cycle operates on reversed Carnot cycle and latent heat of ice is 336 kJ/kg.
3. A glass of water is mixed with ice. The moisture from the air begins to condense on the surface of glass when the temperature of water comes  $12^{\circ}\text{C}$ . If the room temperature and pressure are  $25^{\circ}\text{C}$  and 1.01325 bars, Determine the partial pressure and mass of water vapor in grams per kg of dry air.
4. The pressure and temperature of the mixture of air and water vapor at 1 bar and  $22^{\circ}\text{C}$ . The dew point temperature of the mixture is  $12^{\circ}\text{C}$ . Find partial pressure of water vapor in the mixture, relative humidity, specific humidity, enthalpy of mixture per kg of dry air, and specific volume of mixture per kg of dry air.
5.  $50\text{ m}^3$  of air at  $18^{\circ}\text{C}$  DBT and  $12^{\circ}\text{C}$  WBT are mixed with  $20\text{ m}^3$  of dry air at  $32^{\circ}\text{C}$  DBT and  $24^{\circ}\text{C}$  WBT. Determine the DBT and WBT of the mixture.
6. The DBT and RH of air are  $38^{\circ}\text{C}$  and 60% respectively. The atmospheric pressure is 1 bar. Determine the specific humidity and vapor pressure of moisture in the air. If 10 grams of water vapor is removed from the air and temperature is reduced to  $28^{\circ}\text{C}$ . Find the relative humidity and DPT.
7.  $80\text{ m}^3$  of air per minute at  $32^{\circ}\text{C}$  and 70% is cooled to  $24^{\circ}\text{C}$  DBT (sensible cooling). Find the heat removed from the air, relative humidity of cooled air, WBT of the cooled air (Take air pressure = 1 bar).
- \*8. A perfect reversed heat engine is used for making ice at  $-5^{\circ}\text{C}$  from water available at  $25^{\circ}\text{C}$ . The temperature of the freezing mixture is  $-10^{\circ}\text{C}$ . Calculate the quantity of ice formed per kwh. For ice specific heat =  $2.1\text{ kJ/kg}^{\circ}\text{K}$  and latent heat = 335 kJ/kg.

\* indicates that similar questions have appeared in various university examinations.

# Fluid Mechanics and Hydraulic Machines

## Learning Objectives

*By the end of this chapter, the student will be able:*

- To understand the basic concepts of fluid mechanics and the force analysis
- To describe the construction details, design, and working of hydraulic turbines
- To describe the construction details, design, and working of hydraulic pumps
- To demonstrate the working of hydraulic coupling and torque converter

## FLUID MECHANICS

### 9.1 ► INTRODUCTION

Engineering mechanics can be divided into three parts—mechanics of the rigid body, mechanics of solids, and mechanics of fluids. In the Mechanics of rigid body, it is assumed that there is no internal deformation in the body and we study about the static and dynamic position of the body subjected to external forces. In the mechanics of solid, it is assumed that the solid deforms subjected to external forces and we study about the nature of deformation in the body. In the fluid mechanics, shape and size of the body are not constant and we study about statics and dynamics of flow of fluid subjected to various types of forces on it.

### 9.2 ► PROPERTIES OF FLUIDS

The study of properties of fluids is a base for the basic understanding of flow or static condition of fluids. Some important properties of fluids are density, viscosity, surface tension, bulk modulus and vapor pressure, etc. Viscosity causes resistance to flow between two adjacent

layers of fluid. Surface tension leads to capillary effects. Bulk modulus is involved in the propagation of disturbances like sound waves in fluids. Vapour pressure can cause flow disturbances due to evaporation at locations of low pressure. It plays an important role in cavitation studies in hydraulic machines.

### 9.2.1 Density

The fluid density is the quantity of fluid contained in its unit volume. It can be expressed in three different ways—mass density, specific weight, and relative density.

#### *Mass Density*

Mass Density ( $\rho$ ) is defined as the mass of a substance per unit volume. S.I. unit of mass density is Kilograms per cubic meter,  $\text{kg/m}^3$  and dimensions is  $\text{ML}^{-3}$ .

#### *Specific Weight*

Specific Weight ( $\omega$ ), sometimes  $\gamma$ , and sometimes known as specific gravity is defined as the weight per unit volume or the force exerted by gravity,  $g$ , upon a unit volume of the substance. The Relationship between  $g$  and  $\omega$  can be determined by Newton's 2<sup>nd</sup> Law, since weight per unit volume = mass per unit volume  $\times g$ ;  $\omega \rho = g$ . S.I. unit of fluid is Newton per cubic meter,  $\text{N/m}^3$  and dimension is  $\text{ML}^{-2} \text{T}^{-2}$ .

#### *Relative Density*

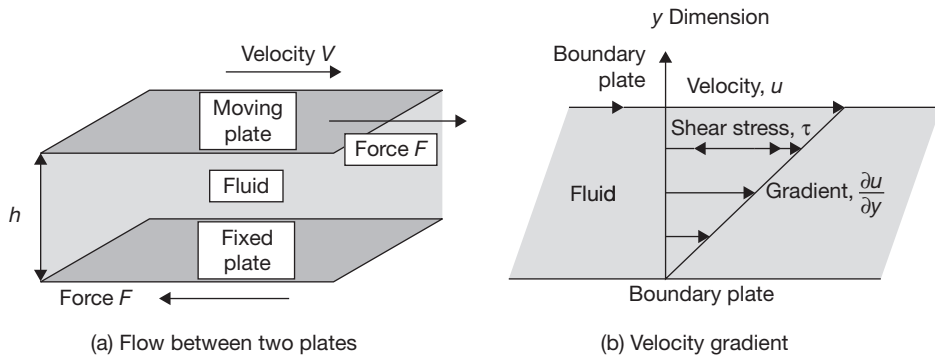
Relative Density ( $\sigma$ ) is defined as the ratio of the mass density of a fluid to some standard mass density. For solids and liquids, this standard mass density is the maximum mass density for water (which occurs at 4° C) at atmospheric pressure.

$$\sigma_{\text{Relative}} = \frac{\sigma_{\text{Fluid}}}{\sigma_{\text{water at 4°C and atmospheric pressure}}}$$

### 9.2.2 Viscosity

Viscosity,  $\mu$  is a property of a fluid which offers resistance to shear deformation. Different fluids deform at different rates under the same shear stress. Fluid with a high viscosity, such as lubricant oil deforms more slowly than the fluid with a low viscosity such as water.

In any fluid flow, layers move at different velocities and the fluid's viscosity arises from the shear stress developed between the layers that ultimately oppose any applied force. The relationship between the shear stress and the velocity gradient can be understood as two plates closely spaced at a distance,  $\partial y$  and separated by a homogeneous substance. Assuming that the plates are of large area 'A' and that the lower plate is fixed. A force 'F' is applied to the


**FIGURE 9.1**

Velocity Variation Near Solid Boundary

upper plate. If this force causes the substance between the plates to undergo shear flow with a velocity gradient  $\partial u / \partial y$ , the substance is called a fluid.

The applied force is proportional to the area and velocity gradient in the fluid. Combining these three relations results in the equation:

$$F \propto A \frac{\partial u}{\partial y} \quad \text{or} \quad F = \mu A \frac{\partial u}{\partial y}$$

Where  $\mu$  is proportionality constant called as *viscosity*.

$$\mu = \frac{F / A}{\frac{\partial u}{\partial y}} = \frac{\tau}{\frac{\partial u}{\partial y}} = \frac{\text{Shear stress}}{\text{Shear strain}}$$

or,

$$\tau = \mu \frac{\partial u}{\partial y}$$

Thus, for straight, parallel and uniform flow, the shear stress between layers is proportional to the velocity gradient in the direction perpendicular to the layers. This statement is known as *Newton's Law of Viscosity*.

Here,  $\mu$  is known as dynamic viscosity and its unit is Newton Second per square meter. The ratio of dynamic viscosity and density of the fluid is known as kinematic viscosity ( $\nu$ ). Its unit is meter<sup>2</sup>/sec. 1 stoke =  $10^{-4}$  m<sup>2</sup>/sec.

$$1 \text{ N-sec/m}^2 = 10 \text{ Poise and } 1 \text{ stoke} = 10^{-4} \text{ m}^2/\text{sec.}$$

**Variations in Viscosity with Temperature:** The viscosity of liquid decreases with increase in temperature while the viscosity of gases increases with increase in temperature.

$$\mu = \mu_0 \left( \frac{1}{1 + \alpha + \beta t^2} \right) \quad \text{for liquids}$$

$$\mu = \mu_0 + \alpha - \beta t^2 \quad \text{for gases}$$

Where  $\alpha$  and  $\beta$  are constants and  $t$  is the temperature.  $\mu_0$  is the viscosity at  $0^\circ \text{C}$ .

### EXAMPLE 9.1

The dynamic viscosity of lubricating oil used between shaft and sleeve is 10 poise. The diameter of the shaft, which rotates at 200 rpm, is 0.5 m. The sleeve length is 100 mm. Calculate the power lost if the thickness of oil film is 2 mm.

### SOLUTION

$$\mu = 10 \text{ poise} = 1 \text{ N sec} / \text{m}^2$$

$$u = \frac{\pi DN}{60} = \frac{\pi \times 0.5 \text{ m} \times 200 \text{ rpm}}{60} = 5.234 \text{ m/sec}$$

$$du = u - 0 = u = 5.234 \text{ m/sec}$$

$$dy = t = 2 \times 10^{-3} \text{ m}$$

$$\tau = \mu \frac{du}{dy} = 1 \times \frac{5.234 \text{ m/sec}}{2 \times 10^{-3} \text{ m}} = 2616.66 \text{ N/m}^2$$

$$\begin{aligned} \text{Shear force on the shaft, } F &= \tau \times A = 2616.66 \text{ N/m}^2 \times \pi DL \\ &= 2616.66 \text{ N/m}^2 \times \pi \times 0.5 \text{ m} \times 100 \times 10^{-3} \text{ m} = 410.81 \text{ N} \end{aligned}$$

$$\text{Torque on shaft, } T = F \times \frac{D}{2} = 410.81 \text{ N} \times 0.25 \text{ m} = 102.70 \text{ Nm.}$$

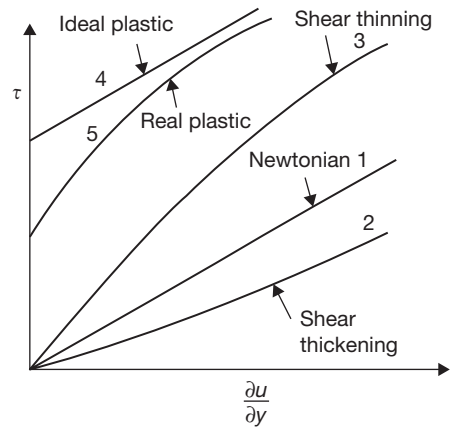
$$\text{Power lost, } P = \frac{2\pi NT}{60} = \frac{2 \times \pi \times 200 \text{ rpm} \times 102.70 \text{ Nm}}{60} = 2149.94 \text{ Watt}$$

## 9.2.3 Newtonian and Non-newtonian Fluids

An ideal fluid has zero viscosity. Shear force is not involved in its deformation. An ideal fluid must be incompressible. Shear stress is zero irrespective of the value of  $\partial u / \partial y$ . Bernoulli equation can be used to analyze the flow. Real fluids having viscosity are divided into two categories, namely, Newtonian and non-Newtonian fluids. In *Newtonian fluids*, a linear relationship exists between the magnitude of the applied shear stress and

the resulting rate of deformation. It means that the proportionality parameter,  $\mu$  is constant in the case of Newtonian fluids. The viscosity at any given temperature and pressure is constant for a Newtonian fluid and is independent of the rate of deformation. The characteristics are shown plotted in Figure 9.2.

Non-Newtonian fluids can be further classified as simple non-Newtonian, ideal plastic and shear thinning, shear thickening and real plastic fluids. In non-Newtonian fluids, viscosity varies with variation in the rate of deformation. A linear relationship between shear stress and rate of deformation ( $\partial u / \partial y$ ) does not exist. In plastics, up to a certain value of applied shear stress, there is no flow. After this limit, it has a constant viscosity at any given temperature. In shear thickening materials, the viscosity increases with ( $\partial u / \partial y$ ) deformation rate. In shear thinning, materials viscosity decreases with  $\partial u / \partial y$ .



**FIGURE 9.2**

Type of Fluids

### 9.2.4 Surface Tension

Surface tension is the tendency of the surface of a liquid to behave like a stretched elastic membrane. There is a natural tendency for liquids to minimize their surface area. The obvious case is that of a liquid droplet on a horizontal surface that is not wetted by the liquid—mercury on glass, or water on a surface that also has a thin film of oil on it. All liquid molecules exhibit cohesive forces binding them with each other. This cohesive bond exhibits a tensile strength of the surface layer and this is known as surface tension.

Surface tension may also be defined as the work (in  $\text{Nm/m}^2$  or  $\text{N/m}$ ) required to create a unit surface area of the liquid. The work is actually required for pulling up the molecules with lower energy from below, to form the surface. Another definition for surface tension is the force required to keep the unit length of the surface film in equilibrium ( $\text{N/m}$ ). The formation of bubbles, droplets, and free jets are due to the surface tension of the liquid.

**Surface Tension on Liquid Droplets:** Let  $\sigma$  be the surface tension of the liquid,  $p$  be the pressure intensity inside the droplets, and  $d$  be the diameter of droplets. The tensile force due to surface tension acting around the circumference of the liquid droplets will be equal to pressure force on the projected area.

$$\sigma \times \pi d = p \times \frac{\pi}{4} d^2 \Rightarrow p = \frac{4\sigma}{d}$$

**Surface Tension on a Hollow Bubble:** A hollow bubble (such as soap bubble) has two surfaces in contact with air—one internal surface and another external surface. Thus, pressure force inside the bubble is equal to two times of tensile force on the bubble surfaces.

$$2 \times \sigma \times \pi d = p \times \frac{\pi}{4} d^2 \Rightarrow p = \frac{8\sigma}{d}$$

Surface tension on a liquid jet:  $p = \frac{2\sigma}{d}$

### EXAMPLE 9.2

The surface tension of water in contact with air at ambient temperature is 0.10 N/m. The pressure inside the water droplet is 0.03 N/cm<sup>2</sup> greater than the outside pressure. Calculate the diameter of the water droplet.

#### SOLUTION

$$\sigma = 0.10 \text{ N/m}; \quad p = 0.03 \times 10^4 \text{ N/m}^2$$

Also, 
$$p = \frac{4\sigma}{d} \Rightarrow d = \frac{4\sigma}{p} = \frac{4 \times 0.1 \text{ N}}{0.03 \times 10^4 \text{ N/m}^2} = 1.33 \text{ mm}$$

### EXAMPLE 9.3

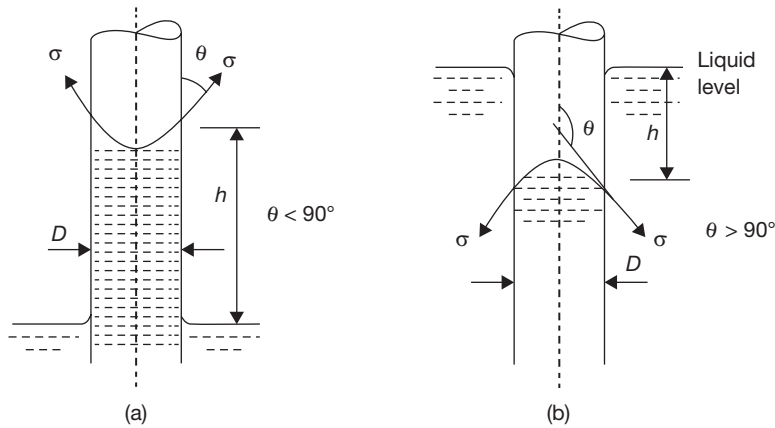
Find the surface tension in a soap bubble of 50 mm diameter when the inside pressure is 4 N/m<sup>2</sup> above atmospheric pressure.

#### SOLUTION

$$p = \frac{8\sigma}{d} \Rightarrow \sigma = \frac{p \times d}{8} = \frac{4 \text{ N/m}^2 \times 50 \times 10^{-3} \text{ m}}{8} = 0.025 \text{ N/m.}$$

## 9.2.5 Capillarity

Capillarity is a phenomenon of rise or fall of the liquid surface in a small tube relative to the adjacent general level of liquid when the tube is held vertically in the liquid. The rise of the liquid surface is known as capillary rise and fall of the liquid surface is known as capillary depression as shown in Figure 9.3.


**FIGURE 9.3**

(a) Capillary Rise and (b) Capillary Depression

**Capillary Rise:** Let  $h$  = height of liquid in the tube,  $\sigma$  = surface tension of the liquid, and  $\theta$  = angle of contact between liquid and glass tube.

The weight of liquid of height in the tube = Area of tube  $\times h \times \rho \times g = \frac{\pi}{4} d^2 \times h \times \rho \times g$

Vertical component of surface tensile force =  $\sigma \times \text{circumference} \times \cos \theta = \sigma \times \pi d \times \cos \theta$

$$\frac{\pi}{4} d^2 \times h \times \rho \times g = \sigma \times \pi d \times \cos \theta$$

$$h = \frac{4\sigma \cos \theta}{\rho \times g \times d}$$

**Capillary Depression:** Let  $h$  = fall in height of liquid in the tube,  $\sigma$  = surface tension of the liquid, and  $\theta$  = angle of contact between liquid and glass tube.

Hydrostatic pressure force acting upward =  $P \times \text{Area of tube}$

$$= h \times \rho \times g \times \frac{\pi}{4} d^2 = \frac{\pi}{4} d^2 \times h \times \rho \times g$$

Vertical component of surface tensile force =  $\sigma \times \text{circumference} \times \cos \theta = \sigma \times \pi d \times \cos \theta$

$$\frac{\pi}{4} d^2 \times h \times \rho \times g = \sigma \times \pi d \times \cos \theta$$

$$h = \frac{4\sigma \cos \theta}{\rho \times g \times d}$$



**EXAMPLE 9.4**

Calculate the capillary rise in a glass tube of diameter 2 mm when immersed vertically in: (i) water and (ii) mercury. Assume surface tension for water as 0.07 and for mercury as 0.5 in contact with air. The specific gravity for mercury is 13.6 and angle of contact is  $130^\circ$ .

**SOLUTION**

Capillary rise for water at  $\theta = 0$

$$h = \frac{4\sigma}{\rho \times g \times d} = \frac{4 \times 0.07 \text{ N/m}}{1000 \text{ kg/m}^3 \times 9.81 \text{ m/sec}^2 \times 2 \times 10^{-3} \text{ m}} = 1.42 \text{ cm}$$

Capillary rise for mercury at  $\theta = 130^\circ$

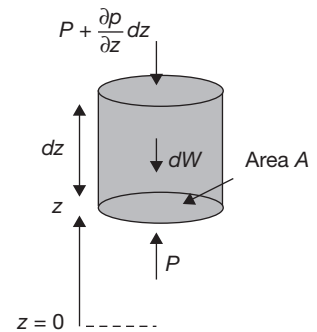
$$h = \frac{4\sigma \times \cos \theta}{\rho \times g \times d} = \frac{4 \times 0.5 \text{ N/m} \times \cos 130^\circ}{(13.6 \times 1000) \text{ kg/m}^3 \times 9.81 \text{ m/sec}^2 \times 2 \times 10^{-3} \text{ m}} = -0.48 \text{ cm}$$

**9.2.6 Pressure Variation with Depth**

The interaction of the static fluid with its surroundings is in the form of force, which is applied equally on all contact points. This force is the result of the pressure applied on a particular unit area. The pressure in the fluid is not constant throughout. The pressure in any body of the fluid varies with depth and it increases with the depth of the fluid. But at the same level relative to the vertical direction the pressure will be same in the fluid. The increase in pressure as we go down the fluid is due to the weight of the fluid column above that level.

The variation of the pressure with the depth of the liquid column can be formulated with this simple analysis. Consider a vertical column of a liquid with a constant cross-sectional area. The liquid under consideration is at rest so there is no shear force acting or coming into the picture. The liquid column is in equilibrium so all the forces are balanced in the column. At any point in the column, the net force is zero. The weight of the column at any particular depth is balanced by the force due to pressure at that point. Thus, the pressure at that point is equal to the weight of the column at that point divided by the area of cross section of the liquid column.

Let  $P$  denote the pressure at the base of the cylinder; since  $p$  changes at a rate  $\frac{\partial p}{\partial z}$  with elevation, the pressure is found from the definition of a derivative to be  $P + \left(\frac{\partial p}{\partial z}\right) dz$  at the

**FIGURE 9.4**

Forces Acting on Cylinder of Fluid

top of the cylinder. (Note that we do not anticipate a reduction of pressure with elevation here; hence, the plus sign is used. If indeed—as proves to be the case—pressure falls with increasing elevation, then the subsequent development will tell us that  $\frac{\partial p}{\partial z}$  is negative.) Hence, the fluid exerts an upward force of  $pA$  on the base of the cylinder, and a downward force of  $[P + (\frac{\partial p}{\partial z}) dz] A$  on the top of the cylinder.

Next, apply Newton's second law of motion by equating the net upward force to the mass times the acceleration which is zero, since the cylinder is stationary:

$$pA - \left( p + \frac{\partial p}{\partial z} dz \right) A - \rho \times A \times dz \times g = 0$$

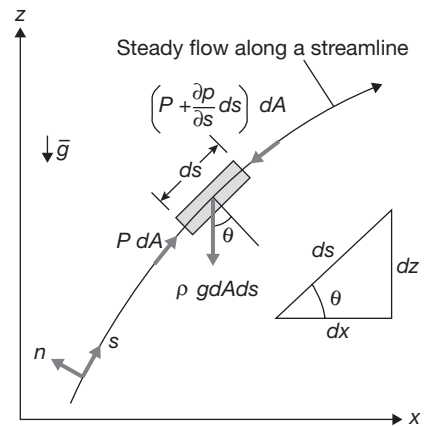
Cancellation of  $PA$  and division by  $A dz$  leads to the following differential equation, which governs the rate of change of pressure with elevation:

$$\frac{\partial p}{\partial z} = -\rho g$$

**Note:** Pressure at the depth  $h$  in a fluid of density  $\rho$  may be given as  $P = P_0 + \rho \times g \times h$ , where  $P_0$  is pressure at the open surface of the fluid.

### 9.3 ► BERNOULLI'S EQUATION

The Bernoulli's equation is an approximate relation between pressure, velocity, and elevation, and is valid in regions of steady and incompressible flow where net frictional forces are negligible. Despite its simplicity, it has proven to be a very useful tool in fluid mechanics. The key approximation in the derivation of the Bernoulli equation is that viscous effects are negligibly small compared to inertial, gravitational, and pressure effects. Since all fluids have a viscosity, this approximation cannot be valid for an entire flow field of practical interest. In other words, we cannot apply the Bernoulli equation everywhere in a flow, no matter how small the fluid's viscosity. However, it turns out that the approximation is reasonable in certain regions of many practical flows. We refer to such regions as inviscid regions of flow, and we stress that they are not regions where the fluid itself is inviscid or frictionless, but rather they are regions where net viscous or frictional forces are negligibly small compared to other forces acting on fluid particles.



**FIGURE 9.5**

Forces on Fluid Element

Considering a streamline flow takes place in  $s$ -direction as shown in Figure 9.5. A small element of fluid of cross-sectional area  $dA$  and length  $ds$  is considered for force analysis. The forces acting on this element are given as:

- (i) pressure force,  $p dA$  in the direction of flow,
- (ii) pressure force  $\left(p + \frac{\partial p}{\partial s} ds\right) dA$  opposite to the direction of flow,
- (iii) the weight of the fluid element,  $\rho g dA ds$ .

The resultant force on the fluid element in the direction of flow must be equal to the mass of fluid element  $\times$  acceleration in the direction.

$$p dA - \left(p + \frac{\partial p}{\partial s} ds\right) dA - \rho g dA ds \cos \theta = \rho dA ds \times a_s \quad (9.1)$$

where  $a_s$  is acceleration in direction  $s$ .

Now, 
$$a_s = \frac{dV}{dt}, \text{ where velocity, } V \text{ is a function of } s \text{ and } t.$$

$$= \frac{\partial V}{\partial s} \frac{ds}{dt} + \frac{\partial V}{\partial t} = \frac{V \partial V}{\partial s} + \frac{\partial V}{\partial t}$$

For steady flow, 
$$\frac{\partial V}{\partial t} = 0$$

$$a = \frac{V \partial V}{\partial s}$$

Putting the value of  $a_s$  in Equation (9.1), we get

$$-\frac{\partial p}{\rho \partial s} - g \cos \theta = \frac{V \partial V}{\partial s}$$

or, 
$$\frac{\partial p}{\rho \partial s} + g \cos \theta + \frac{V \partial V}{\partial s} = 0$$

Therefore,

Putting the value of  $\cos \theta = \frac{dz}{ds}$ ; from Figure 9.5

$$\frac{1}{\rho} \frac{\partial p}{\partial s} + g \frac{dz}{ds} + \frac{V \partial V}{\partial s} = 0$$

or, 
$$\frac{\partial p}{\rho} + g dz + V dV = 0$$

This is known as Euler's Equation of motion.

Bernoulli's equation is obtained by integrating the Euler's equation of motion.

$$\int \frac{dp}{\rho} + \int g dz + \int V dV = \text{constant}$$

$$\frac{p}{\rho} + gz + \frac{V^2}{2} = \text{constant}$$

$$\frac{p}{\rho g} + \frac{V^2}{2g} + z = \text{constant}$$

Here,  $\frac{p}{\rho g}$  represents the pressure energy per unit weight;

$\frac{V^2}{2g}$  represents the kinetic energy per unit weight;

$z$  represents the potential energy per unit weight.

### EXAMPLE 9.5

The water is flowing through a pipe having diameters 30 cm and 20 cm at two sections 1 and 2, respectively. The rate of flow through the pipe is 80 liters/sec. Section 1 is 8 m above the datum and section 2 is 5 m above the datum. If the pressure at section 1 is 4 bar, find the intensity of pressure at section 2.

### SOLUTION

$$\text{Area at section 1, } A_1 = \frac{\pi}{4} d_1^2 = \frac{\pi}{4} (0.3 \text{ m})^2 = 0.07 \text{ m}^2$$

$$\text{Area at section 2, } A_2 = \frac{\pi}{4} d_2^2 = \frac{\pi}{4} (0.2 \text{ m})^2 = 0.0314 \text{ m}^2$$

$$p_1 = 4 \times 10^5 \text{ N/m}^2; z_1 = 8 \text{ m}, z_2 = 5 \text{ m}$$

$$p_2 = ?$$

$$\text{Velocity at section 1, } V_1 = \frac{Q}{A_1} = \frac{0.08 \text{ m}^3 / \text{sec}}{0.07 \text{ m}^2} = 1.142 \text{ m/sec.}$$

$$\text{Velocity at section 2, } V_2 = \frac{Q}{A_2} = \frac{0.08 \text{ m}^3 / \text{sec}}{0.0314 \text{ m}^2} = 2.547 \text{ m/sec.}$$

From Bernoulli's Equation, we get

$$\frac{p_1}{\rho g} + \frac{V_1^2}{2g} + z_1 = \frac{p_2}{\rho g} + \frac{V_2^2}{2g} + z_2$$

$$\begin{aligned}
 &= \frac{4 \times 10^5 \text{ N / m}^2}{1000 \text{ kg / m}^3 \times 9.81 \text{ m / sec}^2} + \frac{(1.142 \text{ m / sec})^2}{2 \times 9.81 \text{ m / sec}^2} + 8 \text{ m} \\
 &= \frac{p_2}{1000 \text{ kg / m}^3 \times 9.81 \text{ m / sec}^2} + \frac{(4.456 \text{ m / sec})^2}{2 \times 9.81 \text{ m / sec}^2} + 5 \text{ m} \\
 & \quad p_2 = 4.201 \text{ bar}
 \end{aligned}$$

## 9.4 ► TYPES OF FLOW

**Steady and Unsteady Flow:** Steady flow is that type of flow in which the fluid characteristics such as velocity, pressure, density, etc. at a point do not change with time. Unsteady flow is that type of flow in which the fluid characteristics such as velocity, pressure, density, etc. at a point change with time.

**Uniform and Non-uniform Flow:** Uniform flow is that type of flow in which velocity of the fluid does not change with respect to space. Non-uniform flow is that type of flow in which velocity of the fluid changes with respect to space.

**Laminar and Turbulent Flow:** Laminar flow is that type of flow in which the fluid particles move along well-defined paths of streamline and all the streamlines are straight and parallel to each other. This type of flow is also known as streamline or viscous flow. Turbulent flow is that type of flow in which fluid particles move in a zig-zag way. This zig-zag motion of the fluid particles results in eddies formation which is responsible for energy loss.

**Compressible and Incompressible Flow:** Compressible flow is that type of flow in which density of fluid changes from point to point. Incompressible flow is that type of flow in which density of fluid remains constant throughout the flow.

**Rotational and Irrotational Flow:** In rotational flow, fluid particles moving on stream lines also rotate about their axes. In irrotational flow fluid particles do not rotate about their axes, they smoothly move in stream line.

# HYDRAULIC MACHINES

## 9.5 ► INTRODUCTION

Hydraulic machines are the devices that convert hydraulic energy into mechanical energy or mechanical energy into hydraulic energy. Hydraulic turbines are the basic prime movers which convert the hydraulic energy (in the form of pressure/kinetic energy) into mechanical energy. Pressure energy is developed due to the head of water in the form of potential energy and kinetic energy is developed due to the mass flow of water with some velocity. The shaft

of hydraulic turbine rotates due to impact/reaction force of water on hydraulic blades; the shaft of the turbine is coupled to a generator which produces electrical energy. Pump converts mechanical energy into hydraulic energy (pressure energy).

## 9.6 ► HYDRAULIC TURBINES

### 9.6.1 Classification of Hydraulic Turbines

There is a number of the basis on which the classification of hydraulic turbines can be done. Some important bases among them are discussed below as:

#### a) Energy Available at the Inlet of the Turbine

*Impulse turbine:* The energy available at the inlet of the turbine is kinetic energy. A jet of water impacts on the turbine blades mounted on the shaft and results in the shaft rotation at high speed. Impulse turbine works on the principle of impulse-momentum equation. The change in momentum of water produces impulse on the blades of the turbine, which acts as torque for rotation of turbine shaft. Example: Pelton turbine.

*Reaction turbines* produce back thrust or reaction on the blade due to the difference in pressure at inlet and outlet of the turbine. The pressure at the inlet of the reaction turbine is more than that of the outlet as the reverse of the impulse turbine in which pressure remains constant at inlet and outlet of the turbine. Example: Francis turbine and Kaplan turbine.

#### b) Direction of Flow of Water

*Tangential flow turbine:* The turbine, in which water flows along the tangent of the runner, is known as tangential flow turbine. Example: Pelton turbine

*Radial flow turbine:* The turbine, in which water flows in a radial direction inward or outward, is known as radial flow turbine.

*Axial flow turbine:* The turbine, in which water flows through the runners along the of the turbine, is known as axial flow turbine. Example: Kaplan turbine.

*Mixed flow turbine:* The turbine, in which water flows through the runner in the radial direction but leaves the turbine in the axial direction, is known as mixed flow turbine. Example: Francis turbine.

#### c) Head

*High head turbine* (Head > 180 meter). Example: Pelton Turbine.

*Medium head turbine* (60 < Head < 150 meter). Example: Francis turbine.

*Low head turbine* (30 < head < 60 meter). Example: Kaplan turbine.

#### d) Specific Speed of the Turbine

*Low specific speed turbine* (10 to 35). Example: Pelton turbine.

*Medium specific speed turbine* (60-300). Example: Francis turbine.

*High specific speed turbine* (300-1000). Example: Kaplan turbine.

## 9.7 ► TERMINOLOGY USED IN TURBINE

**Gross Head:** It is the difference between the water level in reservoir and tail race and indicated by  $H_g$ .

**Net Head:** It is the net head available at the inlet of the turbine after deduction the various types of head losses due to friction, pipe bend, and fitting, etc.

$$H_{net} = H_g - h_f$$

where,  $h_f$  (head loss due to friction) =  $\frac{4fLv^2}{2gD}$

$f$  is coefficient of friction,

$L$  is length of penstock,

$v$  is velocity of water, and

$D$  is diameter of penstock.

**Hydraulic Efficiency:** It is the ratio of power delivered to runner and power available at the inlet of the turbine. Power at inlet of the turbine is more than the power supplied to the runner due to losses in flow through the runner

$$\eta_h \text{ (Hydraulic efficiency)} = \frac{\text{Power delivered to the runner}}{\text{Power available at the inlet of the turbine}}$$

**Mechanical Efficiency:** It is the ratio of the power produced at the shaft of the turbine and power supplied to the runner of the turbine.

$$\eta_{mech} \text{ (Mechanical efficiency)} = \frac{\text{Power produced at the shaft of the turbine}}{\text{Power supplied to the runner}}$$

**Volumetric Efficiency:** It is the ratio of the actual volume of water striking the runner and the volume of water supplied to the turbine.

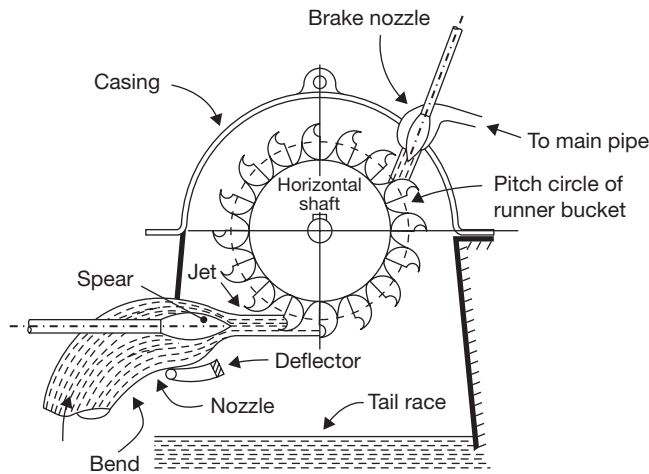
$$\eta_v \text{ (Volumetric efficiency)} = \frac{\text{Actual volume of water striking the runner}}{\text{Volume of the water supplied to the turbine}}$$

**Overall Efficiency:** It is the ratio of the power available at the shaft of the turbine and power supplied at the inlet of the turbine.

$$\eta_o = \frac{\text{Power available at the shaft of the turbine}}{\text{Power supplied at the inlet of the turbine}}$$

## 9.8 ► PELTON TURBINE

Pelton turbine is named after L. A. Pelton an American Engineer; it is a high head, tangential flow, and low specific speed turbine. This turbine is most suitable for the high head. In the case of low head, flow is to be increased and for increased flow, a bigger jet diameter is required. The bigger jet diameter requires bigger runner diameter, which results in the bulky turbine and low peripheral velocity. Thus, the efficiency of Pelton turbine decreases with a low head of the water. A Schematic diagram of Pelton turbine is shown in Figure 9.6.



**FIGURE 9.6**

General Layout of Pelton Turbine

### 9.8.1 Main Components of Pelton Turbine

**Penstock:** Penstock is a steel or concrete conduit, through which water flows from the reservoir to nozzle. Its size is large due to conduction of flow of water from the high head (200 m) to the nozzle.

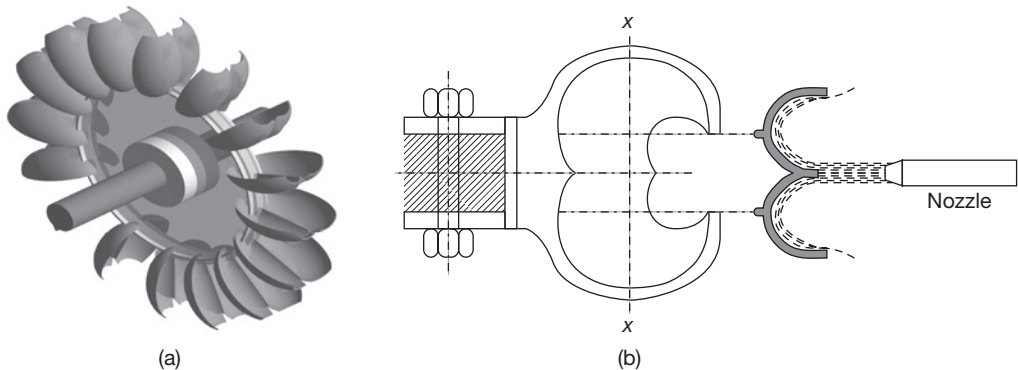
**Nozzle and Guiding Mechanism:** The pressure head at the inlet of the turbine is converted into kinetic energy using the nozzle. The velocity of the of water jet at the tip of the nozzle depends on the net head ( $H$ );  $V = \sqrt{2gH}$ . The high velocity jet of water strikes on the bucket and deviates at  $165^\circ$  and results into impulse on the buckets. Buckets mounted on shaft rotate at high velocity and produce shaft power.

The guide mechanism is used to control the flow of water from the nozzle and to control the speed of the turbine as shown in Figure 9.6. The main function of the spear is to change the flow area of the nozzle moving in forward and backward directions. The flow area is



decreased by the movement of the spear in the forward direction and increased by the movement of the spear in the backward direction. But, water in penstock causes hammering due to sudden increase and decrease pressure resulting from a sudden change in the flow area. Therefore, to prevent the high-pressure generation in the penstock, a deflector is used in front of the nozzle, which deflects the flow of water to decrease the shaft speed.

**Bucket:** The splitter, a sharp edge at the center of the bucket, divides it into two hemispherical part. The splitter helps the jet to be divided into two parts without producing a shock on the bucket and moving the same sideways in opposite directions. The rear of the bucket is so designed that water should not interfere during passage the bucket proceeding in order of rotation as shown in Figure 9.7. The jet should be deflected backward at an angle of  $160^{\circ}$  to  $165^{\circ}$ ; the materials used for the bucket may be cast iron, bronze or stainless steel.



**FIGURE 9.7**

(a) Buckets of Pelton Wheel, and (b) Cross-sectional View of Bucket

**Casing:** Casing has no hydraulic importance; it is only used to prevent the splashing of water and to discharge the water to tail race; and the other purpose is to provide a safeguard to the wheel.

### 9.8.2 Selection of Speed of Pelton Turbine

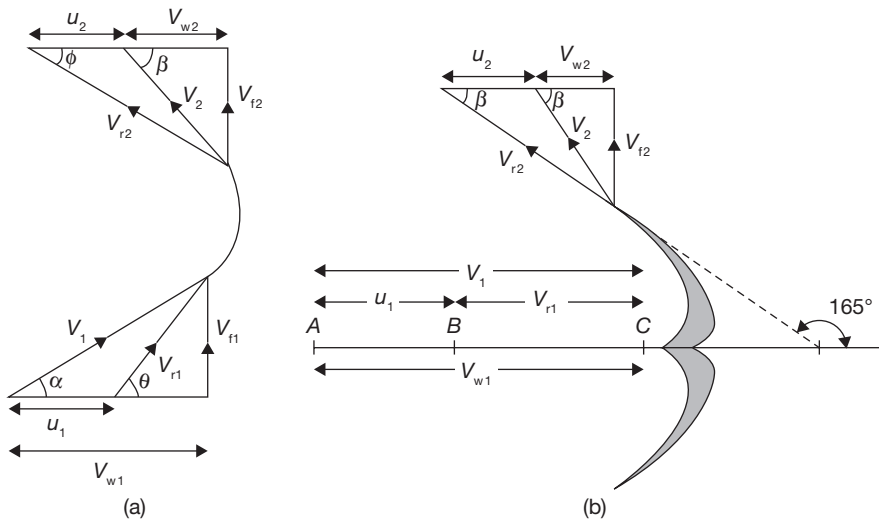
Specific speed of the Pelton turbine ranges from 10 to 35. If the speed of the turbine is made higher, following changes may be required:

- ▶ Specific speed of turbine will increase.
- ▶ Size of the turbine will increase.
- ▶ The jet diameter will decrease to increase the jet ratio and turbine efficiency.
- ▶ Multiple jets will be required; the governing of multiple jet becomes complex.

- The number of poles required in the generator coupled with the turbine will be less due to high speed.

**Hydraulic Brake:** To stop the turbine quickly in short interval of time, some smaller nozzles are fixed in such a way that water jets strike the bucket from the back side.

### 9.8.3 Velocity Triangle for Pelton Turbine



**FIGURE 9.8**

(a) Velocity Triangle for Series of Radial Vane, and (b) Velocity Triangle for Pelton Turbine

Here,  $V_1$  and  $V_2$  are velocities of jet at inlet and outlet, respectively;

$V_{r1}$  and  $V_{r2}$  are relative velocities of jet with respect to bucket at inlet and outlet, respectively;

$u_1$  and  $u_2$  are bucket velocities at inlet and outlet, respectively;

$V_{f1}$  and  $V_{f2}$  are velocities of flow, i.e., component of  $V_1$  and  $V_2$  in the direction of motion of bucket at inlet and outlet, respectively;

$V_{\omega 1}$  and  $V_{\omega 2}$  are velocities of whirl at inlet and outlet, respectively;

$\alpha$  is an angle between the direction of jet and direction of motion of bucket;

$\theta$  is an angle between  $V_{r1}$  and direction of motion of bucket;

$\beta$  is an angle between  $V_2$  and direction of motion of bucket;

$\phi$  is an angle between  $V_{r2}$  and direction of motion of bucket.

In the case of Pelton wheel,  $\alpha = 0$ ,  $\theta = 0$ ,  $u_1 = u_2 = u = \pi DN / 60$ ,  $V_1 = V_{\omega 1}$ ,  $V_{r1} = V_1 - u_1 = V_1 - u$

Where D is the diameter of wheel and N is rpm.

$$V_1 = C_v \sqrt{2gH};$$

where H is net head equals to  $H_g - H_f$ .

$H_g$  and  $H_f$  is gross and friction heads, respectively.  $C_v$  is coefficient of velocity.

From Velocity triangle in Figure 9.8 (b),

$$V_{r2} = V_{r1} \text{ and } V_{\omega 2} = V_{r2} \cos \phi - u$$

Force exerted by water on the bucket,  $F_x = m \{V_{\omega 1} - (-V_{\omega 2})\} = \rho \times a \times V_1 [V_{\omega 1} + V_{\omega 2}]$

$$m = \rho \times a \times V_1, \quad \text{for series of vanes}$$

$$= \rho \times a \times V_{r1}, \quad \text{for single vane}$$

$$a = \frac{\pi}{4} d^2 = \text{Area of jet; where } d \text{ is jet diameter.}$$

Work done by water per sec,  $W = F_x \times u = \rho \times a \times V_1 [V_{\omega 1} + V_{\omega 2}] \times u \text{ Nm / sec.}$

$$\text{Work done per unit weight of water} = \frac{\rho \times a \times V_1 [V_{\omega 1} + V_{\omega 2}] \times u}{\rho \times a \times V_1 \times g} = \frac{[V_{\omega 1} + V_{\omega 2}] \times u}{g}$$

$$\text{Hydraulic efficiency, } \eta_h = \frac{\text{Work done per second}}{\text{Kinetic energy of jet per second}}$$

$$= \frac{\rho \times a \times V_1 [V_{\omega 1} + V_{\omega 2}] \times u}{\frac{1}{2} (\rho \times a \times V_1) \times \rho \times a \times V_1^2} = \frac{2 [V_{\omega 1} + V_{\omega 2}] \times u}{V_1^2}$$

$$V_{\omega 1} = V_1$$

$$V_{\omega 2} = V_{r2} \cos \phi - u = V_{r1} \cos \phi - u = (V_1 - u) \cos \phi - u$$

$$\eta_h = \frac{2 [V_1 + (V_1 - u) \cos \phi - u] \times u}{V_1^2} = \frac{2 (V_1 - u) [1 + \cos \phi] \times u}{V_1^2}$$

For maximum efficiency,  $\frac{d\eta_h}{du} = 0$

$$\frac{d}{du} \left[ \frac{2 (V_1 - u) (1 + \cos \phi) \times u}{V_1^2} \right] = 0$$

or, 
$$u = \frac{V_1}{2} \text{ and } \eta_h = \frac{1 + \cos \phi}{2}$$

**EXAMPLE 9.6**

A Pelton turbine is coupled to an electric generator of 10000 kW. The head of water available at the nozzle is 800 m. Assuming generator efficiency as 95%, Pelton wheel efficiency as 85%, coefficient of velocity for nozzle as 0.96, speed ratio as 0.36, jet deflection angle by the bucket as 165°, and relative velocity at outlet as 0.95 times that of inlet, calculate: (i) diameter of jet, (ii) flow of water in m<sup>3</sup>, and (iii) force exerted by jet on bucket. If the ratio of bucket diameter to jet diameter is 10, find the synchronous speed for the generation at 50 cycles per second and the corresponding mean diameter of the runner.

**SOLUTION**

Given:  $P = 10000 \text{ kW}$ ;  $H = 800 \text{ m}$ ;  $\eta_{\text{gen}} = 0.95$ ;  $\eta_t = 0.85$ ;  $C_v = 0.96$ ;  $C_u = 0.36$ ;  $\phi = 180^\circ - 165^\circ = 15^\circ$

$V_{r2} = 0.95V_{r1}$ ;  $D/d = 10$ ;  $f = 50 \text{ cycles/sec}$ .

$$\text{Power input to the generator, } P_t = \frac{P}{\eta_{\text{gen}}} = \frac{10000 \text{ kW}}{0.95} = 10526.316 \text{ kW.} \quad (9.2)$$

$$\text{Power input to the turbine, } P_a = \frac{P_t}{\eta_t} = \frac{10526.316 \text{ kW}}{0.85} = 12383.901 \text{ kW.} \quad (9.3)$$

$$\text{Also, Power available at the turbine, } P_a = \frac{\rho \times g \times Q \times H}{1000} \text{ kW.} \quad (9.4)$$

$$\begin{aligned} \text{From Eequations (9.2) and (9.3), } Q &= \frac{12383.901 \text{ kW} \times 1000}{1000 \text{ kg/m}^3 \times 9.81 \text{ m/sec}^2 \times 800 \text{ m}} \\ &= 1.5 \text{ m}^3 / \text{sec.} \end{aligned}$$

$$Q = A_{\text{jet}} \times V_1 = \frac{\pi}{4} \times d^2 \times C_v \sqrt{2gH}$$

$$\Rightarrow d = \frac{\sqrt{4Q}}{\sqrt{\pi C_v \sqrt{2gH}}} = \frac{\sqrt{4 \times 1.5 \text{ m}^3 / \text{sec}}}{\sqrt{\pi \times 0.96 \sqrt{2 \times 9.81 \text{ m/sec}^2 \times 800 \text{ m}}}} = 0.126 \text{ m}$$

$$D = 10d = 1.26 \text{ m} \quad A_{\text{jet}} = 0.124 \text{ m}^2$$

$$V_1 = C_v \sqrt{2gH} = 0.96 \sqrt{2 \times 9.81 \text{ m/sec}^2 \times 800 \text{ m}} = 120.272 \text{ m/sec.}$$

$$u_1 = C_u \sqrt{2gH} = 0.36 \sqrt{2 \times 9.81 \text{ m/sec}^2 \times 800 \text{ m}} = 45.102 \text{ m/sec.}$$

$$V_{r1} = V_1 - u_1 = 120.272 \text{ m/sec} - 45.102 \text{ m/sec} = 75.172 \text{ m/sec.}$$

$$V_{r2} = 0.95V_{r1} = 0.95 \times 75.172 \text{ m/sec} = 71.411 \text{ m/sec.}$$

$$u_2 = u_1 = 45.102 \text{ m / sec.}$$

$$V_{\omega 2} = V_{r2} \cos \phi - u_2 = 71.411 \text{ m / sec} \times \cos 15^\circ - 45.102 \text{ m / sec} \\ = 23.876 \text{ m / sec.}$$

$$F_t = \rho Q (V_{\omega 1} + V_{\omega 2}) = 1000 \text{ kg / m}^3 \times 1.5 \text{ m}^3 / \text{sec} \\ (120.272 \text{ m / sec} + 23.876 \text{ m / sec}) \\ = \mathbf{216222.318 \text{ N}}$$

$$N = \frac{u \times 60}{\pi \times D} = \frac{45.102 \text{ m / sec} \times 60}{\pi \times 1.26 \text{ m}} = 683.63 \text{ rpm.}$$

Frequency of generator,  $f = \frac{P \times N}{60}$ , where  $P$  is number of pairs of poles and  $N$  is synchronous speed.

$$N = \frac{f \times 60}{P} = \frac{60 \times 50 \text{ cycles/sec}}{5} = 600 \text{ rpm; Revised diameter} = 1.26 \times \frac{683.63 \text{ rpm}}{600 \text{ rpm}} = 1.43 \text{ m}$$

### EXAMPLE 9.7

A Pelton wheel is to be designed with following specifications: Shaft power = 12000 kW, Head = 400m, Speed = 800 rpm, Overall efficiency = 86%, jet diameter is one-tenth of wheel diameter. Determine: (i) the wheel diameter, (ii) the number of jets required, and (iii) diameter of the jet. Assume  $C_v = 0.98$  and  $C_u = 0.45$ .

### SOLUTION

$$V_1 = C_v \sqrt{2gH} = 0.98 \sqrt{2 \times 9.81 \text{ m / sec}^2 \times 400 \text{ m}} = 86.81 \text{ m / sec.}$$

$$u = u_1 = u_2 = C_u \sqrt{2gH} = 0.45 \sqrt{2 \times 9.81 \text{ m / sec}^2 \times 400 \text{ m}} \\ = 39.86 \text{ m / sec}$$

$$D = \frac{u \times 60}{\pi \times N} = \frac{39.86 \times 60 \text{ m}}{\pi \times 800 \text{ rpm}} = \mathbf{0.951 \text{ m}}$$

$$d = \frac{D}{10} = \frac{0.951 \text{ m}}{10} = \mathbf{0.0951 \text{ m}}$$

$$\text{Discharge of one jet, } q = \frac{\pi}{4} d^2 \times V_1 = \frac{\pi}{4} (0.0951 \text{ m})^2 \times 86.81 \text{ m / sec} = 0.6175 \text{ m}^3 / \text{sec.}$$

$$\text{Overall efficiency, } \eta_o = \frac{\text{Shaft power}}{\text{Water power}} = \frac{12000 \text{ kW}}{\frac{\rho \times g \times Q \times H}{1000}}$$

$$\Rightarrow Q = \frac{12000 \text{ kW} \times 1000}{(0.86 \times 1000) \text{ kg/m}^3 \times 9.81 \text{ m/sec}^2 \times 400 \text{ m}} = 3.555 \text{ m}^3 / \text{sec.}$$

$$\text{Number of jets} = \frac{Q}{q} = \frac{3.555 \text{ m}^3 / \text{sec}}{0.6175 \text{ m}^3 / \text{sec}} = 5.75 \approx \mathbf{6 \text{ jets}}$$

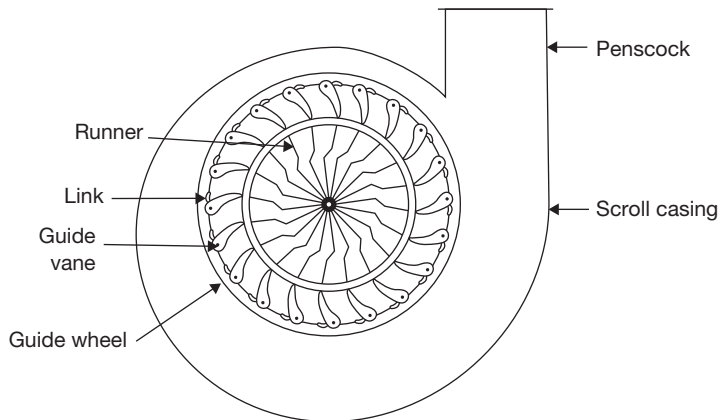
## 9.9 ► FRANCIS TURBINE

Initially, Francis turbine was designed as a pure radial flow reaction turbine by an American Engineer James B. Francis. Modern Francis turbine is mixed flow reaction turbine as water enters the turbine in radial direction and exits in the axial direction. It operates under medium heads and also requires a medium quantity of water. It is employed in the medium head power plants. It covers a wide range of heads from 30 to 150 m. Water is brought down to turbine from reservoir and directed to a number of stationary orifices fixed all around the circumference of a runner, which is known as guide vane.

Water head is partly converted into kinetic head and rest remains as pressure head. There is the difference in pressure between guide vane and runner, called as reaction pressure. The reaction pressure is responsible for the motion of the runner. Therefore, a Francis turbine is called a reaction turbine.

### 9.9.1 Main Components of Francis Turbine

There are following components of Francis Turbine (Figure 9.9)



**FIGURE 9.9**

Francis Turbine

**Penstock:** Penstock is a waterway to carry water from the reservoir to the turbine casing. It is very similar to all types of turbines.

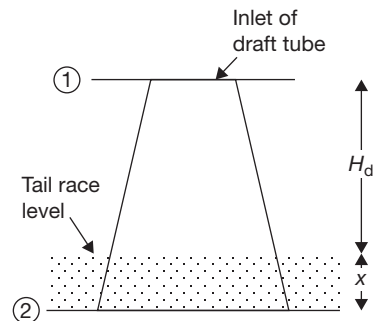
**Spiral or Scroll Casing:** In a spiral casing, the cross sectional area decreases around the periphery of guide wheel from the entrance to tip. A spiral casing is shown in Figure 9.9. This type of casing used to prevent the eddy formation that causes the loss in efficiency.

**Guide Vane:** Guide vanes have aerofoil cross-section to reduce the friction loss and prevent the eddies formation. Each guide vane can turn about its pivot by means of regulating shaft and link connected to guide vane so that it can be opened or closed to allow the passage for the variable quantity of water according to the needs. The regulating shaft is operated by means of a governor whose function is to keep the speed constant to the turbine at varying loads.

**Runner:** Runner is fixed to the turbine shaft. Water flows, radially inward to the runner and exits axially. For high specific speed runner, it is wider than low specific speed runner, since it has to handle a large amount of water. It is made of corrosion resistant materials.

**Draft Tube:** If the water is discharged freely from the runner, the effective head of the turbine will be reduced and will be equal to the height of the reservoir from runner outlet. So a taper draft tube is used at the outlet of the turbine to increase the head of water by the height of the draft tube. Since there is a big loss of head due to high kinetic energy at the outlet of the turbine. The loss is recovered by converting these kinetic head into pressure head at the exit of the draft tube. It is mainly used in reaction turbine.

Let  $H_d$  is the height of the draft tube above the tailrace and  $x$  is a distance of the bottom of the draft tube from tail-race level. From Bernoulli's Equation "Total energy at any section during flow remains constant".



**FIGURE 9.10**

Draft Tube

$$\frac{P_1}{\rho g} + \frac{V_1^2}{2g} + (H_d + x) = \frac{P_2}{\rho g} + \frac{V_2^2}{2g} + h_f + 0$$

Where  $h_f$  is loss of energy due to friction in draft tube

$$\frac{P_2}{\rho g} = \text{Atmospheric pressure head} + x = \frac{P_a}{\rho g} + x$$

Therefore,

$$\frac{P_1}{\rho g} + \frac{V_1^2}{2g} + (H_d + x) = \frac{P_a}{\rho g} + x + \frac{V_2^2}{2g} + h_f$$

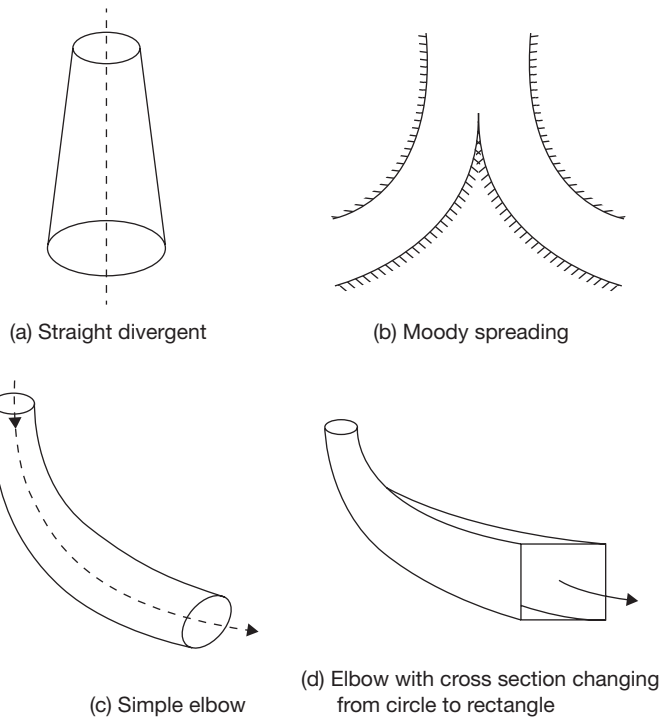
$$\frac{P_1}{\rho g} = \frac{P_a}{\rho g} - H_d - \left( \frac{V_1^2}{2g} - \frac{V_2^2}{2g} - h_f \right)$$

From the above equation, it can be observed that  $P_1 < P_a$

Efficiency of draft tube,

$$\eta_d = \frac{\left( \frac{V_1^2}{2g} - \frac{V_2^2}{2g} \right) - h_f}{\left( \frac{V_1^2}{2g} \right)}$$

### 9.9.2 Different Shapes of Draft Tubes



**FIGURE 9.11**

Different Types of Draft Tubes

### Velocity Triangle for Francis Turbine

Here,  $V_1$  and  $V_2$  are velocities of jet at inlet and outlet, respectively;  
 $V_{r1}$  and  $V_{r2}$  are relative velocities of jet with respect to bucket at inlet and outlet, respectively;  
 $u_1$  and  $u_2$  are bucket velocities at inlet and outlet, respectively;



$V_{f1}$  and  $V_{f2}$  are velocities of flow, i.e., component of  $V_1$  and  $V_2$  in the direction of motion of bucket at inlet and outlet, respectively;

$V_{\omega 1}$  and  $V_{\omega 2}$  are velocities of whirl at inlet and outlet, respectively;

$\alpha$  is an angle between the direction of jet and direction of motion of bucket;

$\theta$  is an angle between  $V_{r1}$  and direction of motion of bucket;

$\beta$  is an angle between  $V_2$  and direction of motion of bucket;

$\phi$  is an angle between  $V_{r2}$  and direction of motion of bucket.

The work done per second on runner by water,

$$W = \rho a V_1 [V_{\omega 1} u_1 \pm V_{\omega 2} u_2] \\ = \rho Q [V_{\omega 1} u_1 \pm V_{\omega 2} u_2]$$

Where  $u_1 = \frac{\pi D_1 N}{60}, u_2 = \frac{\pi D_2 N}{60}$

The work done per second per unit weight of water

$$= \frac{\rho Q (V_{\omega 1} u_1 \pm V_{\omega 2} u_2)}{\rho Q g} = \frac{(V_{\omega 1} u_1 \pm V_{\omega 2} u_2)}{g}$$

Here, +ve sign is taken if  $\beta < 90^\circ$ ; -ve sign is taken if  $\beta > 90^\circ$ , and  $V_{\omega 2} = 0$ , if  $\beta = 90^\circ$ .

In case of Francis turbine  $\beta = 90^\circ$

Now, work done per second per unit weight of water =  $\frac{V_{\omega 1} u_1}{g}$

$$\eta_h = \frac{V_{\omega 1} u_1}{g \times H}; \quad \text{speed ratio} = \frac{V_1}{\sqrt{2gH}} (= 0.65 \text{ to } 0.85); \quad \text{flow ratio} = \frac{V_{f1}}{\sqrt{2gH}} (= 0.5)$$

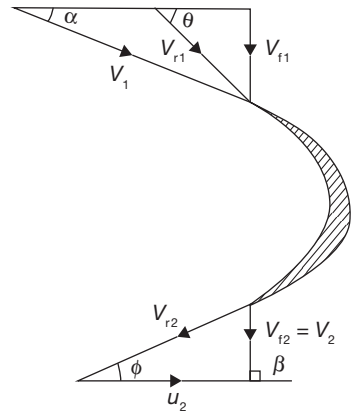


FIGURE 9.12

Velocity Triangle for Francis Turbine

### EXAMPLE 9.8

A Francis turbine working under a head of 8 m. The overall efficiency is 70% and power required to produce 150 kW. The peripheral and radial velocities at inlet are  $0.3\sqrt{2gH}$  and  $0.96\sqrt{2gH}$ , respectively. The wheel runs at 160 rpm and hydraulic efficiency of the turbine is 78%. Assuming radial discharge, find (i) the guide blade angle, (ii) vane angle at inlet, (iii) diameter of the wheel at the inlet, and (iv) width of the wheel at the inlet.

**SOLUTION**

Given:

$$\eta_o = 70\%, \eta_h = 78\%, \text{ Shaft power} = 150\text{ kW}, H = 8\text{ m}$$

$$u_1 = 0.3\sqrt{2gH} = 0.3\sqrt{2 \times 9.81\text{ m/sec}^2 \times 8\text{ m}} = 3.75\text{ m/sec.}$$

$$V_{f1} = 0.96\sqrt{2gH} = 0.96\sqrt{2 \times 9.81\text{ m/sec}^2 \times 8\text{ m}} = 12.02\text{ m/sec.}$$

$$N = 160\text{ rpm}$$

There is radial discharge at outlet, therefore  $V_{\omega 2} = 0$  and  $V_{f2} = V_2$ .

$$\text{Hydraulic efficiency, } \eta_h = \frac{V_{\omega 1} u_1}{gH} = 0.78$$

$$\Rightarrow V_{\omega 1} = \frac{0.78 \times 9.81\text{ m/sec}^2 \times 8\text{ m}}{3.75\text{ m/sec}} = 16.32\text{ m/sec.}$$

(i) Guide blade angle,  $\alpha$

$$\begin{aligned} \tan \alpha &= \frac{V_{f1}}{V_{\omega 1}} = \frac{12.02\text{ m/sec}}{16.32\text{ m/sec}} = 0.736 \Rightarrow \alpha = \tan^{-1} 0.736 \\ &= 36.37^\circ \end{aligned}$$

(ii) Wheel vane angle at inlet,  $\theta$

$$\begin{aligned} \tan \theta &= \frac{V_{f1}}{V_{\omega 1} - u_1} = \frac{12.02\text{ m/sec}}{16.32\text{ m/sec} - 3.75\text{ m/sec}} = 0.956 \\ \Rightarrow \theta &= \tan^{-1} 0.956 = 43.71^\circ \end{aligned}$$

(iii) Diameter of wheel at inlet,  $D_1$

$$D_1 = \frac{60 \times u_1}{\pi \times N} = \frac{60 \times 3.75\text{ m/sec}}{\pi \times 160\text{ rpm}} = 0.447\text{ m}$$

(iv) Width of the wheel at inlet,  $b_1$

$$\begin{aligned} \eta_o &= \frac{\text{Shaft power}}{\text{Water power}} = \frac{150\text{ kW}}{\frac{\rho \times g \times Q \times H}{1000}} \\ \Rightarrow Q &= \frac{150\text{ kW} \times 1000}{1000 \times 9.81\text{ m/sec}^2 \times 8\text{ m} \times 0.7} = 2.73\text{ m}^3/\text{sec.} \\ 2.73\text{ m}^3/\text{sec} &= \pi \times 0.447\text{ m} \times b_1 \times 12.02\text{ m/sec} \\ b_1 &= \frac{2.73\text{ m}^3/\text{sec}}{\pi \times 0.447\text{ m} \times 12.02\text{ m/sec}} = 0.1617\text{ m} \end{aligned}$$

**EXAMPLE 9.9**

An inward flow reaction turbine rotates at 360 rpm. The wheel vanes are radial at the inlet and the inner diameter of the wheel is half of the outer diameter. The constant velocity of flow in the wheel is 2.5 m/sec. Water enters the wheel at an angle of 15° to the tangent at the wheel at the inlet. The width of the wheel at the inlet is 90 mm and area of flow blocked by vane is 2% of the gross area of flow at the inlet. Assuming radial discharge, find (i) head available, (ii) vane angle at the outlet, (iii) the outer and inner diameter of the wheel, and (iv) the theoretical water power developed by the wheel.

**SOLUTION**

$$V_{f1} = V_1 \sin \alpha = V_{f2}$$

$$V_1 = \frac{V_{f1}}{\sin \alpha} = \frac{2.5 \text{ m/sec}}{\sin 15^\circ} = \frac{2.5 \text{ m/sec}}{0.2588} = 9.659 \text{ m/sec.}$$

$$V_{\omega} = u_1 = V_1 \cos \alpha = 9.659 \text{ m/sec} \cos 15^\circ = 9.33 \text{ m/sec.}$$

$$u_1 = \frac{\pi D_1 N}{60} \Rightarrow D_1 = \frac{u_1 \times 60}{\pi \times N} = \frac{9.33 \text{ m/sec} \times 60}{\pi \times 360 \text{ rpm}} = \mathbf{0.4949 \text{ m}}$$

$$D_2 = \frac{0.4949 \text{ m}}{2} = \mathbf{0.247 \text{ m}}$$

Head available,  $H = \frac{V_{\omega} u_1}{g} = \frac{9.33 \text{ m/sec} \times 9.33 \text{ m/sec}}{9.81} = \mathbf{8.87 \text{ m}}$

$$u_2 = \frac{\pi \times D_2 \times N}{60} = \frac{\pi \times 0.247 \text{ m} \times 360 \text{ rpm}}{60} = 4.655 \text{ m/sec.}$$

$$V_{f2} = V_{f1} = 2.5 \text{ m/sec.}$$

$$\tan \phi = \frac{V_{f2}}{u_2} = \frac{2.5 \text{ m/sec}}{4.655 \text{ m/sec}} = 0.536$$

or  $\phi = \mathbf{28.23^\circ}$

Quantity of water flow,  $Q = \text{area of flow} \times \text{velocity of flow}$

$$= K \times \pi \times D_1 \times b_1 \times V_{f1}$$

$$= 0.98 \times \pi \times 0.4449 \text{ m} \times 0.09 \text{ m} \times 2.5 \text{ m/sec} = 0.3428 \text{ m}^3 / \text{sec.}$$

Water power,  $P_a = \frac{\rho \times g \times Q \times H}{1000}$

$$= \frac{1000 \text{ kg/m}^3 \times 9.81 \text{ m/sec}^2 \times 0.3428 \text{ m}^3 / \text{sec} \times 8.87 \text{ m}}{1000} = \mathbf{29.828 \text{ kW}}$$

## 9.10 ► KAPLAN TURBINE

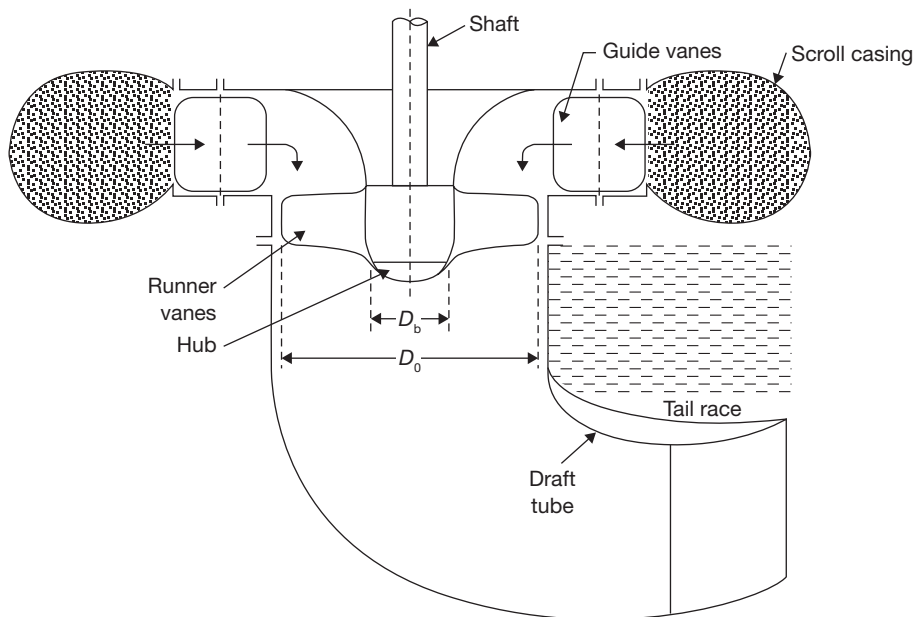
Kaplan turbine is an axial flow, low head, high specific speed, reaction type turbine. There is a similar turbine known as propeller turbine having fixed vane in place of the adjustable vane as in Kaplan turbine.

Kaplan turbine has following components (Figure 9.13 and 9.14):

**Scroll Casing:** Its function is very similar to scroll casing in Francis turbine as explained earlier. It reduces the eddies formation and hence minimizes the eddy loss.

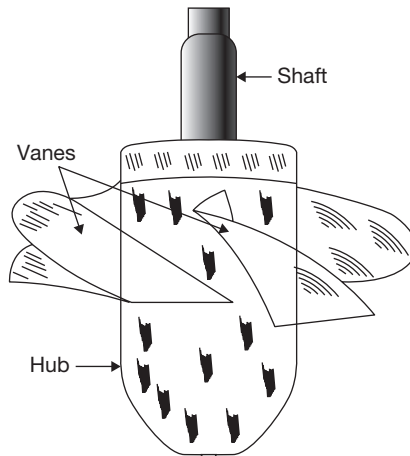
**Guide Mechanism:** It has a similar function as in Francis turbine.

**Hub, Vane/Runner:** The extended bottom end of the shaft is known as hub boss. On the periphery of boss 3 to 6 vanes are mounted that are fixed in propeller turbine and adjustable in Kaplan turbine. Propeller turbine is used where head and load are constant but Kaplan turbine is used where load and head are variable. During operation, vanes are adjusted by Servomotor mechanism. Servomotor mechanism consists of a cylinder with a piston working under oil pressure on either side.



**FIGURE 9.13**

Main Components of Kaplan Turbine



**FIGURE 9.14**  
Kaplan Turbine

### 9.10.1 Velocity Triangle for Kaplan Turbine

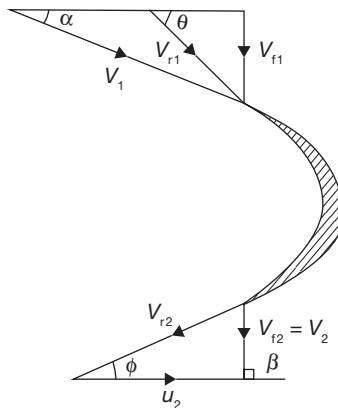
Area of flow at inlet =  $\frac{\pi}{4}(D_o^2 - D_b^2)$ , where  $D_o$  is outer diameter of runner and  $D_b$  is hub diameter.

Velocity of flow at inlet = Velocity of flow at outlet

i.e.,  $V_{f1} = V_{f2}$

Peripheral velocity at inlet and outlet are equal,  $u = u_1 = u_2 = \frac{\pi D_o N}{60}$

Discharge through runner,  $Q = \frac{\pi}{4}(D_o^2 - D_b^2) \times V_{f1}$



**FIGURE 9.15**

Velocity Triangle for Kaplan Turbine

**EXAMPLE 9.10**

A Kaplan turbine is working under a head of 20 m. The hub diameter is 0.25 times the runner diameter. The rpm of the turbine is 500. Runner angle at the outlet is  $15^\circ$  and flow ratio is 0.6. Calculate: (i) diameter of runner and (ii) discharge rate of water.

**SOLUTION**

$$H = 20\text{ m}, D_b = 0.25D_0, N = 500\text{ rpm}, \phi = 15^\circ$$

$$\text{Flow ratio} = 0.6 = \frac{V_{f1}}{\sqrt{2gH}}$$

$$V_{f1} = 0.6\sqrt{2 \times 9.81\text{ m/sec}^2 \times 20\text{ m}} = 11.885\text{ m/sec} = V_{f2}$$

$$\tan \phi = \frac{V_{f2}}{u_2} \Rightarrow u_2 = \frac{V_{f2}}{\tan \phi} = \frac{11.885\text{ m/sec}}{0.267} = 44.355\text{ m/sec}$$

For Kaplan turbine,  $u_1 = u_2 = 44.355\text{ m/sec}$ .

$$u_1 = \frac{\pi \times D_0 \times N}{60} \text{ or } D_0 = \frac{60 \times u_1}{\pi \times N} = \frac{60 \times 44.355\text{ m}}{\pi \times 500\text{ rpm}} = 1.694\text{ m}$$

$$D_b = 0.25D_0 = 0.25 \times 1.694\text{ m} = \mathbf{0.433235\text{ m}}$$

$$\begin{aligned} \text{Discharge rate} &= \frac{\pi}{4} (D_0^2 - D_b^2) \times V_{f1} \\ &= \frac{\pi}{4} \left( (1.694\text{ m})^2 - (0.423\text{ m})^2 \right) \times 11.885\text{ m/sec} = \mathbf{25.11\text{ m}^3/\text{sec}} \end{aligned}$$

**EXAMPLE 9.11**

A Kaplan turbine is designed to develop 7000 kW shaft power. The head available is 10 m. Assuming speed ratio as 2.1, flow ratio as 0.6, overall efficiency as 70%, and diameter of the boss as one-third of the diameter of runner. Find the diameter of runner and its speed.

**SOLUTION**

$$\text{Speed ratio, } 2.1 = \frac{u_1}{\sqrt{2gH}} \Rightarrow u_1 = 2.1 \times \sqrt{2 \times 9.81\text{ m/sec}^2 \times 10\text{ m}} = 29.41\text{ m/sec}$$

$$\text{Flow ratio, } 0.6 = \frac{V_{f1}}{\sqrt{2gH}} \Rightarrow V_{f1} = 0.6 \times \sqrt{2 \times 9.81\text{ m/sec}^2 \times 10\text{ m}} = 8.4\text{ m/sec}$$

$$\eta_o = 0.7 = \frac{\text{Shaft power}}{\text{Water power}} = \frac{7000 \text{ kW}}{\frac{\rho g Q H}{1000}} = \frac{7000 \text{ kW} \times 1000}{1000 \text{ kg/m}^3 \times 9.81 \text{ m/sec}^2 \times Q \times 10 \text{ m}}$$

$$\Rightarrow Q = 101.93 \text{ m}^3 / \text{sec}$$

$$\text{Also, } Q = \frac{\pi}{4} (D_o^2 - D_b^2) \times V_{f1}$$

$$\text{or } 101.93 \text{ m}^3 / \text{sec} = \frac{\pi}{4} \left[ D_o^2 - \left( \frac{D_o}{3} \right)^2 \right] \times V_{f1}$$

$$\text{or } D_o = \sqrt{\frac{101.93 \text{ m}^3 / \text{sec} \times 4 \times 9}{\pi \times 8 \times V_{f1}}} = \sqrt{\frac{101.93 \text{ m}^3 / \text{sec} \times 4 \times 9}{\pi \times 8 \times 8.4 \text{ m/sec}}} = 4.16 \text{ m}$$

$$D_b = \frac{1}{3} \times 4.16 \text{ m} = 1.389 \text{ m}$$

$$u_2 = \frac{\pi \times D_o \times N}{60}$$

$$N = \frac{60 \times u_2}{\pi \times D_o} = \frac{60 \times 29.41 \text{ m/sec}}{\pi \times 4.16 \text{ m}} = 135.02 \text{ rpm}$$

### EXAMPLE 9.12

A conical draft tube having inlet and outlet diameters 2 m and 2.5 m discharges water at the outlet with a velocity of 3 m/sec. The total length of the draft tube is 8 m out of which 2 m of the length of the draft tubes immersed in water. If atmospheric pressure head is 10.3 m of water and loss of head due to friction in the draft tube is equal to 0.2 times of velocity head at the outlet of the tube. Find: (i) pressure head at inlet and (ii) Efficiency of draft tubes.

### SOLUTION

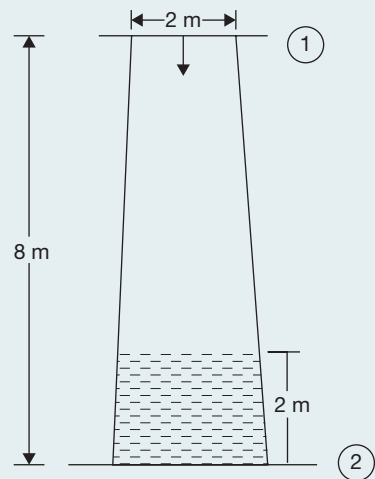
$$D_1 = 2 \text{ m}, D_2 = 2.5 \text{ m}, V_2 = 3 \text{ m/s}$$

$$H_d + x = 8 \text{ m}, x = 2 \text{ m}$$

$$H_d = 8 - 2 = 6 \text{ m}$$

$$h_f = 0.2 \times \frac{V_2^2}{2g} = 0.2 \times \frac{(3 \text{ m/sec})^2}{2 \times 9.81 \text{ m/sec}^2} = 0.091 \text{ m}$$

$$\frac{P_a}{\rho g} = 10.3 \text{ m}$$



$$Q = A_2 \times V_2 = \frac{\pi}{4} \times D_2^2 \times 3 = \frac{\pi}{4} \times (2.5\text{ m})^2 \times 3\text{ m/sec} = 14.72\text{ m}^3/\text{sec}$$

$$V_1 = \frac{Q}{A_1} = \frac{14.72\text{ m}^3/\text{sec}}{\frac{\pi}{4} \times (2\text{ m})^2} = 4.687\text{ m/sec}$$

$$\begin{aligned} \text{(i) Pressure head at inlet, } \frac{P_1}{\rho g} &= \frac{P_a}{\rho g} - H_d - \left( \frac{V_1^2}{2g} - \frac{V_2^2}{2g} - h_f \right) \\ &= 10.3\text{ m} - 6\text{ m} - \left( \frac{(4.687\text{ m/sec})^2}{2 \times 9.81\text{ m/sec}^2} - \frac{(3\text{ m/sec})^2}{2 \times 9.81\text{ m/sec}^2} - 0.091\text{ m} \right) \\ &= 3.73\text{ m (abs.)} \end{aligned}$$

$$\begin{aligned} \text{(ii) Efficiency of draft tube, } \eta_d &= \frac{\frac{V_1^2}{2g} - \frac{V_2^2}{2g} - h_f}{\frac{V_1^2}{2g}} = \frac{1.119\text{ m} - 0.4587\text{ m} - 0.091\text{ m}}{1.119\text{ m}} \\ &= 50.87\% \end{aligned}$$

### Cavitation

Cavitation is defined as the phenomenon of formation of vapor bubbles due to fall in pressure below its vapor pressure and sudden bursting of these bubbles in a high-pressure zone. It is an undesirable phenomenon.

### Effects of Cavitation

- (i) Cavities are formed on the surface and metallic surface is damaged.
- (ii) Due to sudden collapse of vapor bubbles, considerable noise and vibrations are produced.
- (iii) The efficiency of turbine decreases.

Cavitation depends on vapor pressure, absolute or barometric pressure, suction pressure, and effective dynamic head and absolute velocity of water at runner exit.

### Precaution against Cavitation

- (i) Pressure of flowing fluid at any part should not fall below vapor pressure.
- (ii) Specific materials or coating such as aluminum, bronze, and stainless steel, which are capitation resistant materials should be used.



## 9.11 ► GOVERNING OF TURBINES

Governing of turbines is required to control the speed of the turbine since it is coupled with an electric generator with fixed number of poles provided in the generator. The speed of the turbine is controlled by controlling the water flow. This is done by means of a governor, which is running due to the motion of the shaft of the turbine. There is a servomotor in which cylinder and piston are used to control the flow area of water by a spear. If the turbine speed increases due to decreasing load on the generator, the speed is reduced by decreasing the flow of water with the help of spear movement controlled by piston and cylinder servomotors.

## 9.12 ► PUMPS

Working principle of hydraulic pumps is the just reverse of the hydraulic turbines. Hydraulic turbine transforms the hydraulic energy into mechanical work whereas hydraulic pump transforms mechanical work into hydraulic energy. The pumps may be a reciprocating type or rotary type. Centrifugal pump is a rotary type pump, which is used for large delivery and small head and the reciprocating pump is used for small delivery and high head.

## 9.13 ► CENTRIFUGAL PUMP

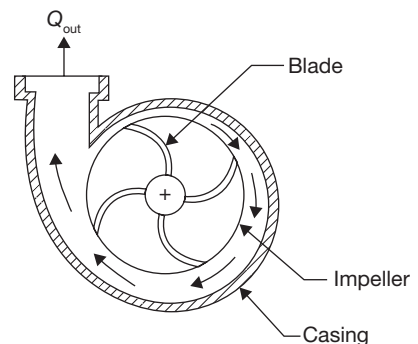
Centrifugal pump works on the reverse of the principle of working of radial inward flow reaction turbine. The pressure at the periphery will be high due to centrifugal force on the water. The centrifugal force is subjected on the water due to forced vortex motion. Water enters in the axial direction and leaves radial direction (Figure 9.16). The pressure is proportional to the square of radius as a rise in pressure head.

$$F = \frac{V^2}{2g} = \frac{\omega^2 r^2}{2g}$$

Due to high-pressure head at the periphery, water can be lifted to a higher level.

### 9.13.1 Main Components of Centrifugal Pump

Main components of a centrifugal pump are Impeller, casing, suction pipe, foot valve, strainer, delivery pipe as further discussed.

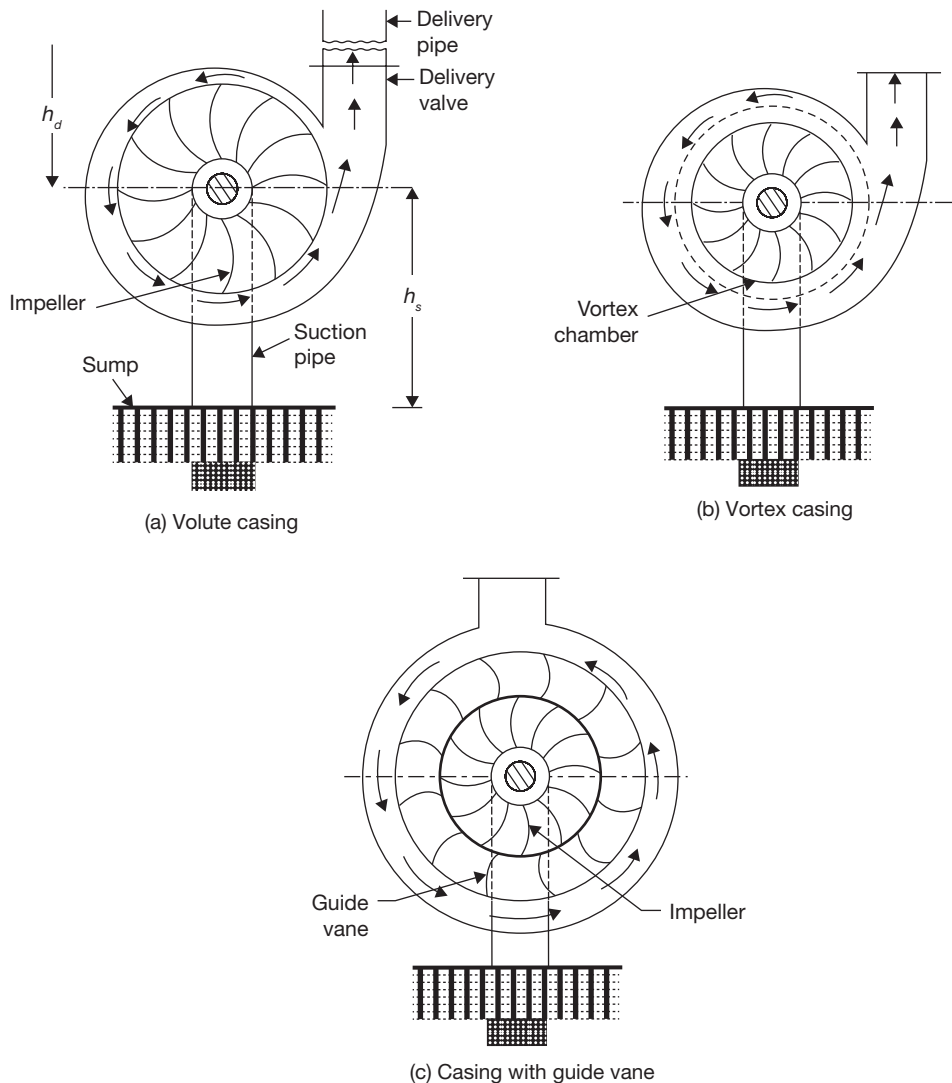


**FIGURE 9.16**

Construction Feature of Centrifugal Pump

**Impeller:** Impeller is a backward curved vane. It is mounted on the shaft coupled to the electric motor. Thus, it is a rotating part of centrifugal pump.

**Casing:** It is air tight passage surrounding the pump. Its function is to convert the kinetic energy of water into pressure energy before entering the delivery pipe. Different types of casing used in the centrifugal pump are volute casing, vortex casing, and casing with guide blade as shown in Figure 9.17 (a), (b), and (c).



**FIGURE 9.17**

Different Types of Casing Used in Centrifugal Pump

The volute casing is a spiral type casing. The area of the passage increases gradually so that velocity of water decrease and pressure increases. The main limitation of this casing is eddies formation which causes the loss of energy. In vortex casing, eddies formation is eliminated by employing a circular chamber in between impeller and casing as shown in Figure 9.17 (b). Thus, the efficiency of vortex casing is more than that of volute casing.

Casing with guide blades allows water to enter into the guide blade without shocks. Guide blade works as a diffuser, since the area of guide blade increases, which converts the kinetic energy of water into pressure energy.

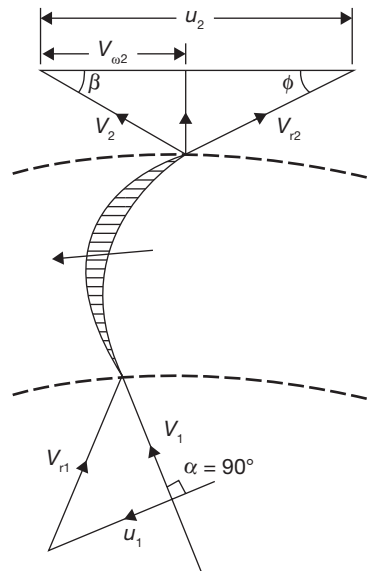
**Suction Pipe, Foot-valve, and Strainer:** A pipe, whose one end is connected to the inlet of the pump and other end dips into the water in a sump, is known as a suction pipe. A foot valve is a non-return type valve which is fitted with the lower end of the suction pipe. The foot valve opens only in upward direction. A strainer is also fitted at the lower end of the suction pipe. It works as a filter.

**Delivery Pipe:** A pipe, whose one end is connected to the outlet of the pump and other end is connected to the supply at some height, is known as a delivery pipe.

### 9.13.2 Velocity Triangle for Centrifugal Pump

Here,

- ▶  $N$  is the speed of impeller in rpm;
- ▶  $D_1, D_2$  are diameter of impeller at inlet and outlet, respectively;
- ▶  $U_1, u_2$  are tangential velocities at inlet and outlet, respectively;
- ▶  $V_1, V_2$  are absolute velocities of water at inlet and outlet, respectively;
- ▶  $V_{r1}, V_{r2}$  are the relative velocities of water at inlet and outlet;
- ▶  $\alpha$  is an angle made by absolute velocity  $V_1$  at the inlet with the direction of motion of vane;
- ▶  $\theta$  is an angle between  $V_{r1}$  and the direction of motion of vane;
- ▶  $\beta, \phi$  are the corresponding angles of  $\alpha$  and  $\theta$  at the outlet.



**FIGURE 9.18**

Velocity Triangle for Centrifugal Pump

The Water enters the impeller radially, therefore  $\alpha = 0^\circ$ ,  $V_{\omega 1} = 0$ .

Work done per unit weight of water by impeller

$$W = -\left(\frac{V_{\omega 1} u_1 - V_{\omega 2} u_2}{g}\right) = \frac{V_{\omega 2} u_2}{g}$$

Work done by impeller on water per second =  $\rho Q V_{\omega 2} u_2$

### 9.13.3 Various Heads and Efficiencies of Centrifugal Pumps

**Suction Head,  $h_s$ :** It is height of center (eye) of the pump from water level.

**Delivery Head,  $h_d$ :** It is the height of the tank from the center of the pump.

**Static Head,  $H_s$ :** it is the sum of suction and delivery heads, i.e.,  $H_s = h_s + h_d$

**Manometric Head,  $H_m$ :** It is the head against which a centrifugal pump has to work.

$$H_m = \left(\frac{P_o}{\rho g} + \frac{V_o^2}{2g} + z_o\right) - \left(\frac{P_i}{\rho g} + \frac{V_i^2}{2g} + z_i\right);$$

where subscript  $o$  is used for outlet and  $i$  is used for inlet.

$$\begin{aligned} H_m &= \frac{V_{\omega 2} u_2}{g} - \text{Losses in impeller and casing} \\ &= h_s + h_d + h_{fs} + h_{fd} + \frac{V_d^2}{2g} \end{aligned}$$

where  $h_{fs}$  is friction loss in suction pipe;  $h_{fd}$  is friction loss in delivery pipe, and  $V_d$  is discharge velocity

$$\text{Manometric efficiency } (\eta_{\text{man}}) = \frac{\text{Manometric head}}{\text{Head imparted by impeller on water}} = \frac{gH_m}{V_{\omega 2} u_2}$$

$$\text{Mechanical efficiency } (\eta_{\text{mech}}) = \frac{\text{Power at the impeller}}{\text{Power at the shaft}} = \rho Q \left(\frac{V_{\omega 2} u_2}{1,000}\right) / \text{Shaft power}$$

$$\text{Overall efficiency } (\eta_o) = \eta_{\text{man}} \times \eta_{\text{mech}} = \left(\frac{\rho Q \times H_m}{1,000}\right) / \text{Shaft power}$$

### 9.13.4 Some Important Points Related to Centrifugal Pump

(i) Minimum speed required for starting a centrifugal pump:

$$N = \frac{120 \times \eta_{\text{max}} \times V_{\omega 2} \times D_2}{\pi(D_2^2 - D_1^2)}$$

- (ii) In multistage centrifugal pump:
- For high head, pumps are coupled in series
  - For high discharge, pumps are coupled in parallel
  - Specific speed,

$$N_s = \frac{N\sqrt{Q}}{H_m^{3/4}}$$

- (iii) Priming of centrifugal pump: Priming of a centrifugal pump is defined as the operation in which the suction pipe, casing of the pump and a part of the delivery pipe up to the delivery valve is completely filled with water and air from these parts of the pump is removed.

### EXAMPLE 9.13

A centrifugal pump running at 1,500 rpm has internal and external impeller diameter of 200 mm and 300 mm, respectively. The vane angles of the impeller at inlet and outlet are  $25^\circ$  and  $30^\circ$ , respectively. If water enters the impeller radially and velocity of flow remains constant. Determine the work done by the impeller per unit weight of water.

### SOLUTION

$$u_1 = \frac{\pi \times D_1 \times N}{60} = \frac{\pi \times 0.2 \text{ m} \times 1500 \text{ rpm}}{60} = 15.7 \text{ m / sec.}$$

$$u_2 = \frac{\pi \times D_2 \times N}{60} = \frac{\pi \times 0.3 \text{ m} \times 1500 \text{ rpm}}{60} = 23.56 \text{ m / sec.}$$

$$\tan \theta = \frac{V_{f1}}{u_1}$$

$$\Rightarrow V_{f1} = \tan \theta \times u_1 = \tan 25^\circ \times 15.7 \text{ m / sec} = 7.32 \text{ m / sec}$$

$$\tan \phi = \frac{V_{f2}}{u_2 - V_{\omega 2}} = \frac{7.32 \text{ m / sec}}{23.56 \text{ m / sec} - V_{\omega 2}}$$

$$\begin{aligned} \Rightarrow V_{\omega 2} &= 23.56 \text{ m / sec} - \frac{7.32 \text{ m / sec}}{\tan \phi} = 23.56 \text{ m / sec} - \frac{7.32 \text{ m / sec}}{\tan 30^\circ} \\ &= 10.879 \text{ m / sec.} \end{aligned}$$

$$\text{Work done by impeller per kg of water per second} = \frac{V_{\omega 2} u_2}{g}$$

$$= \frac{10.879 \text{ m / sec} \times 23.56 \text{ m / sec}}{9.81 \text{ m / sec}^2} = 26.1287 \text{ Nm / sec.}$$

**EXAMPLE 9.14**

A centrifugal pump having an internal and external diameter of impeller 150 mm and 600 mm, respectively, is running at 800 rpm. It has a constant velocity of flow of 3 m/sec and discharges through the pump are  $0.03 \text{ m}^3/\text{sec}$ . The diameters of suction and delivery pipes are 100 mm and 75 mm, respectively and suction and delivery heads are 5 m and 25 m of water, respectively. If outlet vane angle is  $40^\circ$  and power required to drive the pump is 15 kW, determine: (i) vane angle at the inlet, (ii) overall efficiency of the pump, and (iii) manometric efficiency of the pump.

**SOLUTION**

Given:  $D_1 = 150 \text{ mm}$ ;  $D_2 = 600 \text{ mm}$ ;  $N = 800 \text{ rpm}$ ;  $V_{f1} = V_{f2} = 3 \text{ m/s}$ ;  
 $Q = 0.03 \text{ m}^3/\text{s}$ ;  $d_s = 100 \text{ mm}$ ;  $d_d = 75 \text{ mm}$ ;  $H_s = 5 \text{ m}$ ;  $H_d = 25 \text{ m}$ ;  $\phi = 40^\circ$ ;  
 $P = 15 \text{ kW}$ .

$$(i) \quad u_1 = \frac{\pi \times D_1 \times N}{60} = \frac{\pi \times 0.15 \text{ m} \times 800 \text{ rpm}}{60} = 6.283 \text{ m/s}$$

$$\tan \theta = \frac{V_{f1}}{u_1} = \frac{3 \text{ m/sec}}{6.283 \text{ m/sec}} = 0.477 \Rightarrow \theta = 25.5^\circ$$

$$(ii) \quad V_d = \frac{\text{Discharge}}{\text{Area of delivery pipe}} = \frac{0.03 \text{ m}^3/\text{sec}}{\frac{\pi}{4} \times (0.075 \text{ m})^2} = 6.79 \text{ m/s}$$

$$V_s = \frac{\text{Discharge}}{\text{Area of suction pipe}} = \frac{0.03 \text{ m}^3/\text{sec}}{\frac{\pi}{4} \times (0.1 \text{ m})^2} = 3.81 \text{ m/s}$$

$$H_m = \left( \frac{p_o}{\rho g} + \frac{V_o^2}{2g} + z_o \right) - \left( \frac{p_i}{\rho g} + \frac{V_i^2}{2g} + z_i \right)$$

Here, subscript o stands for outlet and i stands for inlet

$$z_o = z_i$$

$$\therefore H_m = \left( \frac{p_o}{\rho g} + \frac{V_o^2}{2g} \right) - \left( \frac{p_i}{\rho g} + \frac{V_i^2}{2g} \right); \quad V_o = V_d \quad \text{and} \quad V_i = V_s$$

$$H_m = \left( 25 \text{ m} + \frac{(6.79 \text{ m/sec})^2}{2 \times 9.81 \text{ m/sec}^2} \right) - \left( 5 \text{ m} + \frac{(3.81 \text{ m/sec})^2}{2 \times 9.81 \text{ m/sec}^2} \right) = 21.6 \text{ m}.$$

$$\begin{aligned} \text{Overall efficiency of the pump, } \eta_o &= \frac{W_{Hm}}{\text{Shaft power}} = \frac{\rho \times g \times Q \times H_m}{1000P} = \frac{\rho \times g \times Q \times H_m}{1000P} \\ &= \frac{1000 \text{ kg/m}^3 \times 9.81 \text{ m/sec}^2 \times 0.03 \text{ m}^3/\text{sec} \times 21.6 \text{ m}}{1000 \times 15 \text{ kW}} = 42.37\% \end{aligned}$$

(iii) Manometric efficiency of the pump

$$\begin{aligned} u_2 &= \frac{\pi D_2 N}{60} = \frac{\pi \times 0.6 \text{ m} \times 800 \text{ rpm}}{60} = 25.132 \text{ m/sec.} \\ \tan \phi &= \frac{V_{f2}}{u_2 - V_{\omega 2}} = \frac{3 \text{ m/sec}}{25.132 \text{ m/sec} - V_{\omega 2} \text{ m/sec}} \\ \Rightarrow V_{\omega 2} &= 25.132 \text{ m/sec} - \frac{3 \text{ m/sec}}{\tan 40^\circ} = 21.557 \text{ m/sec} \\ \eta_{man} &= \frac{gH_m}{V_{\omega 2} \times u_2} = \frac{9.81 \text{ m/sec}^2 \times 21.6 \text{ m}}{21.557 \text{ m/sec} \times 25.132 \text{ m/sec}} = 39.11\% \end{aligned}$$

### EXAMPLE 9.15

Following data of a centrifugal pump are given as: Diameter at inlet = 0.5 m; Diameter at outlet = 1.0 m; Speed = 250 rpm; Flow rate = 1800 liters/sec; Vane exit angle =  $25^\circ$ ; Velocity of flow = 3 m/sec; head = 8 m. Find the least speed to start the pump and manometric efficiency.

### SOLUTION

$$\begin{aligned} u_2 &= \frac{\pi \times D_2 \times N}{60} = \frac{\pi \times 1 \text{ m} \times 250 \text{ rpm}}{60} = 13.08 \text{ m/sec.} \\ \tan \phi &= \frac{V_{f2}}{u_2 - V_{\omega 2}} = \frac{3 \text{ m/sec}}{13.08 \text{ m/sec} - V_{\omega 2}} \Rightarrow V_{\omega 2} = 13.08 \text{ m/sec} - \frac{3 \text{ m/sec}}{\tan 25^\circ} \\ &= 6.64 \text{ m/sec} \\ \eta_{man} &= \frac{gH_m}{V_{\omega 2} \times u_2} = \frac{9.81 \text{ m/sec}^2 \times 8 \text{ m}}{6.64 \text{ m/sec} \times 13.08 \text{ m/sec}} = 90.27\% \\ u_1 &= \frac{\pi \times D_1 \times N}{60} = \frac{\pi \times 0.5 \text{ m} \times 250 \text{ rpm}}{60} = 6.54 \text{ m/sec} \end{aligned}$$

Least speed to start the pump

$$\frac{u_2^2}{2g} - \frac{u_1^2}{2g} = H_m \quad \text{or} \quad \frac{(\omega r_2)^2}{2g} - \frac{(\omega r_1)^2}{2g} = H_m$$

$$\frac{\omega(1\text{m})^2}{8g} - \frac{\omega(0.5\text{m})^2}{8g} = 8\text{m} \Rightarrow \omega = 837.12 \text{ rad/sec} = \frac{2\pi N}{60}$$

$$N = \frac{837.12 \text{ rad/sec} \times 60 \text{ sec}}{2 \times \pi} = 7993.9 \text{ rpm}$$

## 9.14 ► RECIPROCATING PUMP

In a centrifugal pump, the transformation of energy from mechanical to hydraulic form is done by rotating action of the impeller, but in the reciprocating pump, this energy transformation is done by the reciprocating action of the piston. In a reciprocating pump, the rotary motion of crankshaft is converted into the reciprocating motion of pump by means of a connecting rod. Pressure on water is applied by reducing the volume by positive displacement method.

The main components of the reciprocating pump are a cylinder, piston, or plunger, connecting rod, crank, suction pipe, and delivery pipe as shown in Figure 9.19. Suction and delivery pipes are connected to the cylinder through one-way valves. In a single acting reciprocating pump, piston moves towards right through  $0^\circ$  to  $180^\circ$  of the crank and small vacuum is created inside the cylinder. Due to this vacuum, suction valve is pushed up and water enters into the cylinder. When the piston moves towards right through  $180^\circ$  to  $360^\circ$  of crank rotation, suction valve is closed and the delivery valve is open due to the high pressure of water. Thus, water is forced into the delivery pipe and raised to a required height.

Discharge through centrifugal pump,

$$Q = \frac{ALN}{60} \quad \text{for single acting reciprocating pump}$$

$$= \frac{2ALN}{60} \quad \text{for double acting reciprocating pump}$$

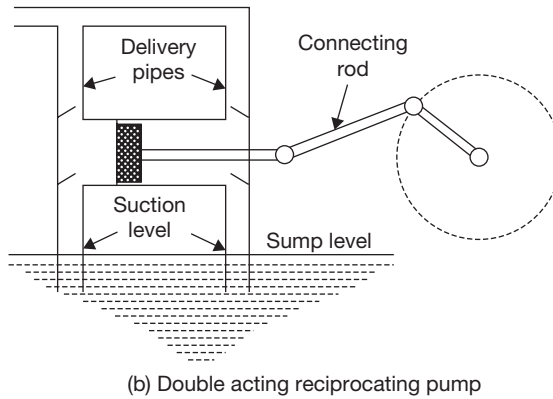
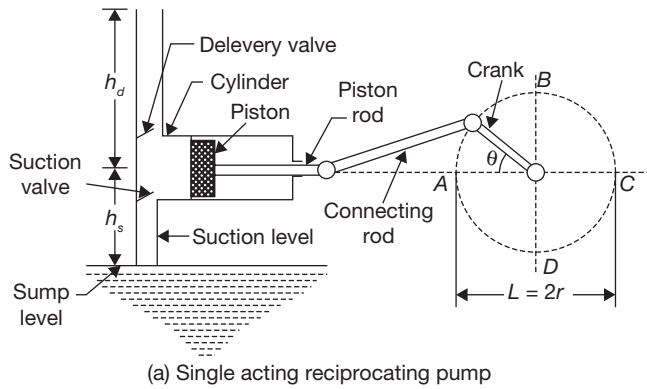
$$\text{Power deveeed, } P = \frac{ALN}{60} \times \rho g \times (h_s + h_d) \quad \text{for single acting reciprocating pump}$$

$$= \frac{2ALN}{60} \times \rho g \times (h_s + h_d) \quad \text{for double acting reciprocating pump}$$

**Slip:** It is difference between theoretical and actual discharge of reciprocating pump

$$\text{Slip} = Q_{\text{theoretical}} - Q_{\text{actual}}$$

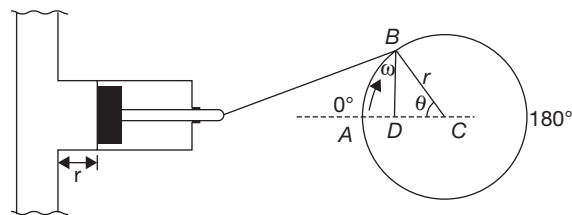




**FIGURE 9.19**

Working of Reciprocating Pump

*Variation in Acceleration Head in the Suction and Delivery Pipes Due to Acceleration of the Piston*



**FIGURE 9.20**

Velocity and Acceleration of Piston

Pressure head due to acceleration in suction and delivery pipes:

$$h_{as} = \frac{l_s}{g} \times \frac{A}{a_s} \times \omega^2 r \cos \theta$$

$$h_{ad} = \frac{l_d}{g} \times \frac{A}{a_d} \times \omega^2 r \cos \theta$$

where  $A$  is area of piston and  $a_s$  and  $a_d$  areas of suction and delivery pipes, respectively.

Thus, acceleration heads depend on the value of  $\theta$ .

### Variation in Friction Head in Suction and Delivery Pipes Due to Variation in Velocity of Piston

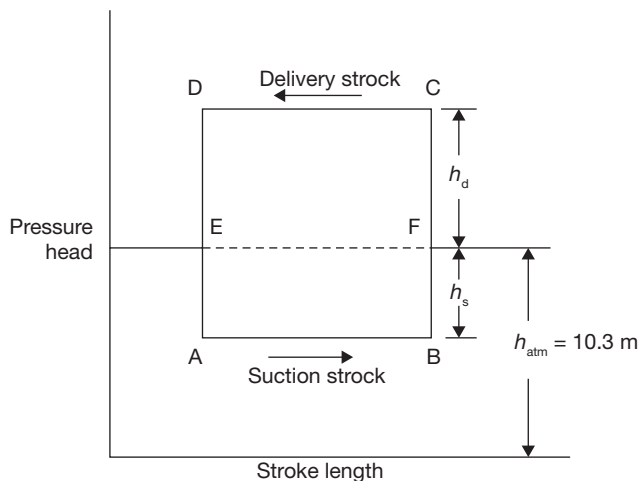
Head loss due to friction is given by

$$h_f = \frac{4fLV^2}{2gd}, \text{ where the value of } V \text{ depends on } \theta, \text{ i.e., } V = \frac{A}{a} \omega \sin \theta$$

$$h_{fs} = \frac{4fl_s}{2gd_s} \left( \frac{A}{a_s} \omega \sin \theta \right)^2, \text{ and } h_{fd} = \frac{4fl_d}{2gd_d} \left( \frac{A}{a_d} \omega \sin \theta \right)^2$$

At  $\theta = 90^\circ$  head loss due to friction will be maximum and at  $\theta = 0^\circ$  head loss will be zero.

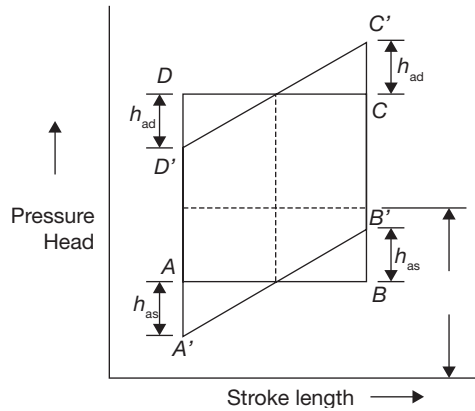
**Case I:** When acceleration heads and friction heads are zero.



**FIGURE 9.21**

Ideal Indicator Diagram without Acceleration and Friction Heads

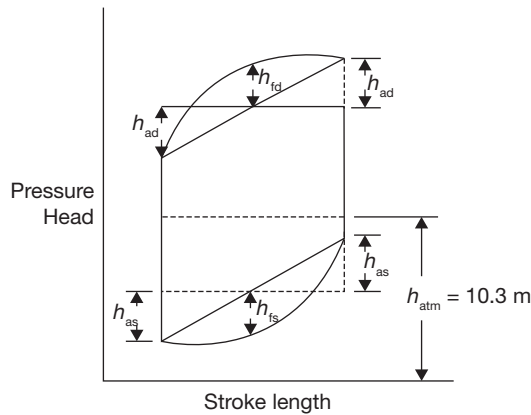
*Case II:* When acceleration heads are not equal to zero.



**FIGURE 9.22**

Indicator Diagram, When Acceleration Heads are not Equal to Zero, But Friction Heads are Zero.

*Case III:* When acceleration heads and friction heads are not equal to zero



**FIGURE 9.23**

Indicator Diagram, When Acceleration Heads and Friction Heads are not Equal to Zero

Work done by pump for a single acting reciprocating pump

$$W = \frac{\rho g A L N}{60} \left( h_s + h_d + \frac{2}{3} h_{fs} + \frac{2}{3} h_{fd} \right)$$

Work done by pump for a double acting reciprocating pump

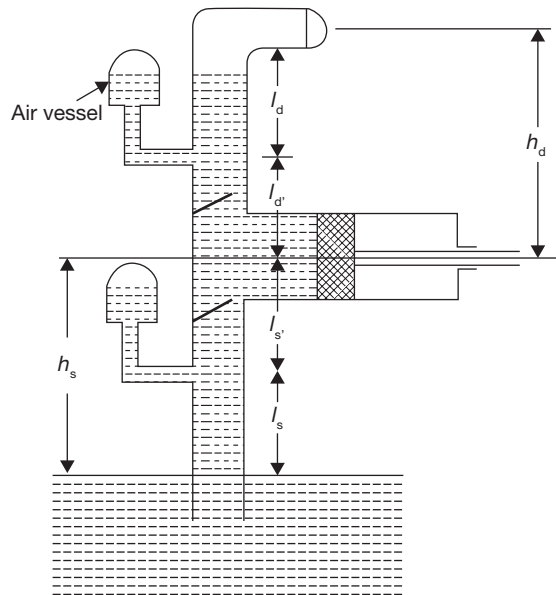
$$W = \frac{2\rho gALN}{60} \left( h_s + h_d + \frac{2}{3}h_{fs} + \frac{2}{3}h_{fd} \right)$$

$$h_f = \frac{4fLV^2}{2gd}; \text{ where } \bar{V} = \frac{A}{a} \times \omega r$$

### 9.14.1 Air Vessels

Air vessel is a closed chamber containing compressed air in the top space and liquid at the bottom of the chamber. At the base of the chamber, there is an opening through which the liquid (water) may flow into or out from the vessel. When liquid enters the air vessel, air gets compressed and when liquid exits from the vessel, the air gets expanded. An air vessel is fitted to the suction pipe and to the delivery pipe at a point close to the cylinder of a single acting reciprocating pump. The purposes of its application are as given below:

- (i) to obtain a continuous supply of liquid at a uniform rate,
- (ii) to save a considerable amount to work in overcoming the friction resistance in the suction and delivery pipes, and
- (iii) to run the pump at high speed without separation.



**FIGURE 9.24**

Reciprocating Pump with Air Vessels

Work done by reciprocating pump with air vessels fitted to suction and delivery pipes

$$W = \frac{\rho g A L N}{60} [h_s + h_d + h_{fs} + h_{fd}]$$

Work done by reciprocating pump with air vessels fitted to suction and delivery pipes

$$W = \frac{\rho g A L N}{60} [h_s + h_d + h_{fs} + h_{fd}]$$

$$h_f = \frac{4 f l \bar{V}^2}{2 g d}; \text{ where } \bar{V} = \frac{A}{a} \times \frac{\omega r}{\pi}$$

### EXAMPLE 9.16

A single acting reciprocating pump running at 100 rpm delivers  $0.10 \text{ m}^3/\text{sec}$  of water. The diameter of the piston is 500 mm and the stroke length is 400 mm. Determine: (i) the theoretical discharge, (ii) percentage slip, and (iii) coefficient of discharge.

### SOLUTION

$$Q_{\text{theoretical}} = \frac{L \times A \times N}{60} = \frac{0.4 \text{ m} \times \frac{\pi}{4} \times (0.5 \text{ m})^2 \times 100 \text{ rpm}}{60 \text{ sec}} = 0.13 \text{ m}^3/\text{sec}$$

$$Q_{\text{actual}} = 0.10 \text{ m}^3/\text{sec}$$

$$\text{Slip} = Q_{\text{theoretical}} - Q_{\text{actual}} = 0.13 - 0.10 = 0.03$$

$$\% \text{ slip} = \frac{Q_{\text{theoretical}} - Q_{\text{actual}}}{Q_{\text{theoretical}}} \times 100 = \frac{0.03 \text{ m}^3/\text{sec}}{0.13 \text{ m}^3/\text{sec}} \times 100 = 23.07\%$$

$$\text{Co-efficient of discharge} = \frac{Q_{\text{actual}}}{Q_{\text{theoretical}}} = \frac{0.1 \text{ m}^3/\text{sec}}{0.13 \text{ m}^3/\text{sec}} = 0.769$$

### EXAMPLE 9.17

A double acting reciprocating pump has a piston of 300 mm diameter and piston rod of 60 mm diameter. Stroke length is 400 mm and speed is 50 rpm. The suction and discharge heads are 8 m and 18 m, respectively. Determine: (i) the force required to run the pump during in and out strokes, (ii) quantity of water in  $\text{m}^3/\text{sec}$  raised by the pump, and (iii) power required to run the pump.

**SOLUTION**

Given:  $D = 300\text{ mm}$ ;  $d = 60\text{ mm}$ ;  $L = 400\text{ mm}$ ;  $N = 50\text{ rpm}$ ;  $H_s = 8\text{ m}$ ; and  $H_d = 18\text{ m}$

(i) Force required during in-stroke,  $F = \rho g [A \times H_s + (A - a)H_d]$

$$= 1000\text{ kg/m}^3 \times 9.81\text{ m/s}^2 \left[ \frac{\pi}{4} \times D^2 \times H_s + \left( \frac{\pi}{4} \times D^2 - \frac{\pi}{4} \times d^2 \right) H_d \right]$$

$$= 1000\text{ kg/m}^3 \times 9.81\text{ m/s}^2 \left[ \frac{\pi}{4} \times (0.3\text{ m})^2 \times 8\text{ m} + \left( \frac{\pi}{4} \times (0.3\text{ m})^2 - \frac{\pi}{4} \times (0.06\text{ m})^2 \right) 18\text{ m} \right]$$

$$= \mathbf{13.831\text{ kN}}$$

Force required during out-stroke =  $F = \rho g [A \times H_d + (A - a)H_s]$

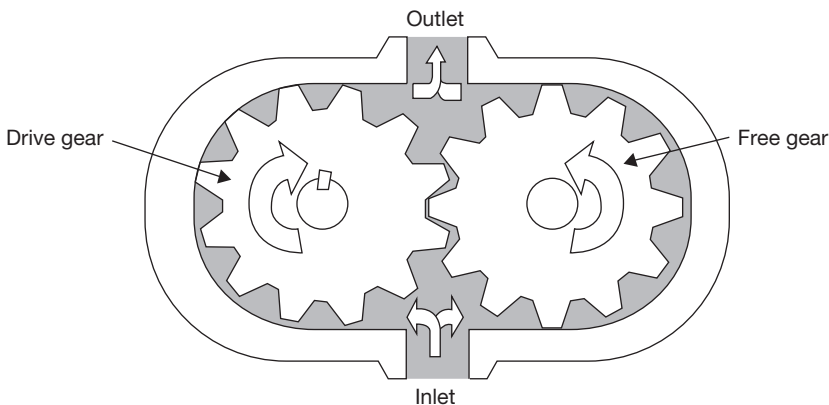
$$= 1000\text{ kg/m}^3 \times 9.81\text{ m/s}^2 \left[ \frac{\pi}{4} \times D^2 \times H_d + \left( \frac{\pi}{4} \times D^2 - \frac{\pi}{4} \times d^2 \right) H_s \right]$$

$$= 1000\text{ kg/m}^3 \times 9.81\text{ m/s}^2 \left[ \frac{\pi}{4} \times (0.3\text{ m})^2 \times 18\text{ m} + \left( \frac{\pi}{4} \times (0.3\text{ m})^2 - \frac{\pi}{4} \times (0.06\text{ m})^2 \right) 8\text{ m} \right]$$

$$= 17.807\text{ kN}$$

$$(ii) \quad Q = \frac{2LAN}{60} = \frac{2 \times 0.4\text{ m} \times \frac{\pi}{4} \times (0.3\text{ m})^3 \times 50\text{ rpm}}{60\text{ sec}} = \mathbf{0.0471\text{ m}^3/\text{sec}}$$

$$(iii) \quad \text{Power required} = \frac{\rho \times g \times Q \times H}{1000} = \frac{1000\text{ kg/m}^3 \times 9.81\text{ m/s}^2 \times 0.0471\text{ m}^3/\text{sec} \times (8 + 18)\text{ m}}{1000} \\ = \mathbf{12.01\text{ kW}}$$

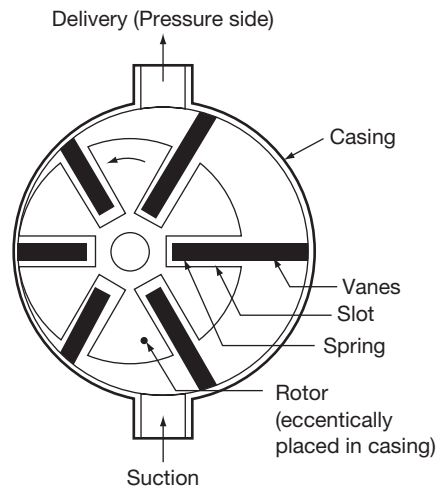
**9.15 ► GEAR PUMP**

**FIGURE 9.25**

Schematic Diagram of Gear Pump

A gear pump maintains the flow of fluid by carrying the fluid between the teeth of two meshed gears. One gear is connected to drive shaft and other is meshed with the first gear. The pumping chambers formed between the gear teeth are enclosed by the pump housing and the side plates. A low-pressure region is created at the inlet as the gear teeth separate. As a result, fluid flows in and is carried around by the gears. As the teeth mesh again at the outlet, high pressure is created and the fluid is forced out. Figure 9.25 shows the construction of an internal gears pump; most of the gear type pumps are fixed displacement. They range in output from very low to high volume. Usually, they operate at comparatively low pressure.

### 9.16 ► VANE PUMP

In a vane pump, a rotor is coupled to the drive shaft and rotates inside a cam ring. Vanes are fitted to the rotor slots and follow the inner surface of the ring as the rotor turns (Figure 9.26). Centrifugal force and pressure under the vanes keep them pressed against the ring. Pumping chambers are formed between the vanes and are enclosed by the rotor, ring, and two side plates. At the pump inlet, a low-pressure region is created as the space between the rotor and ring increases. Oil entering here is trapped in the pumping chambers and then is forced into the outlet as the volume decreases.

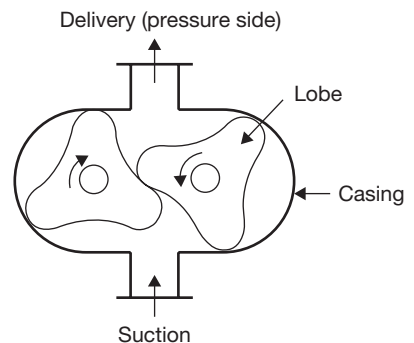


**FIGURE 9.26**

Vane Pump

### 9.17 ► LOBE PUMP

This is also used to pump oils. The schematic diagram of a lobe pump is shown in Figure 9.27. This is a three-lobed pump. The two-lobed pump is also used. Two lobes are arranged in a casing. As the rotor rotates, oil is trapped in the space between the lobe and the casing and is carried to the pressure side. Helical lobes along the axis are used for the smooth operation. Oil has to be filled before starting the pump. The constant contact between the lobes makes a leak tight joint preventing oil leakage from the pressure side. The maximum pressure of operation is controlled by the back leakage through the clearance. This type of pump has a higher capacity compared to the gear pump.



**FIGURE 9.27**

Lobe Pump

## 9.18 ► SCREW PUMP

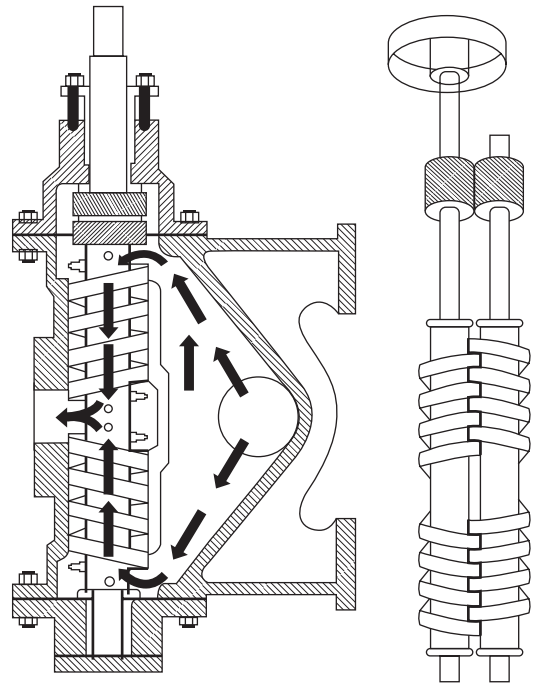
There are many variants screw type positive displacement, rotary pump. The various design depends on the number of intermeshing screws involved, the pitch of the screws, and the direction of fluid flow. Two common designs are the two-screw, low-pitch, double-flow pump, and the three-screw, high-pitch, double-flow pump.

### 9.18.1 Two-screw, Low-pitch, Screw Pump

The two-screw, low-pitch, screw pump consists of two screws of right handed and left handed threads mesh with close clearances, mounted on two parallel shafts. The driving shaft drives the other shaft through a set of herringbone timing gears. The gears maintain the clearances between the screws as they rotate and to promote quiet operation. The screws rotate in closely fitting duplex cylinders that have overlapping bores. All clearances are small, but there is no actual contact between the two screws or between the screws and the cylinder walls.

The complete assembly and the flow diagram are shown in Figure 9.28. The liquid is trapped at the outer end of each pair of screws. As the first space between the screw threads rotates away from the opposite screw, a one-turn, spiral-shaped quantity of liquid is enclosed when the end of the screw again meshes with the opposite screw. As the screw continues to rotate, the entrapped spiral turns

of the liquid slide along the cylinder toward the center discharge space while the next slug is being entrapped. Each screw works in similar fashion, and each pair of screws discharges an equal quantity of liquid in opposed streams toward the center, thus eliminating hydraulic thrust. The removal of liquid from the suction end by the screws produces a reduction in pressure, which draws liquid through the suction line.



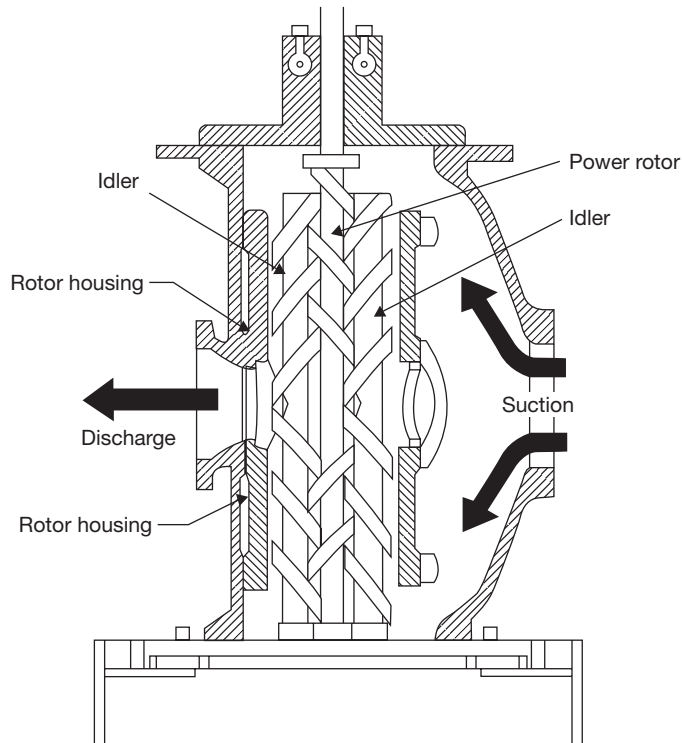
**FIGURE 9.28**

Two-screw, Low-pitch, Screw Pump

### 9.18.2 Three-screw, High-pitch, Screw Pump

The three-screw, high-pitch, screw pump has many of the same elements as the two-screw, low-pitch, screw pump, and their operations are similar as shown in Figure 9.29. Three





**FIGURE 9.29**

Three-screw, High-pitch, Screw Pump

screws, oppositely threaded on each end, are employed. They rotate in a triple cylinder, the two outer bores of which overlap the center bore. The pitch of the screws is much higher than in the low pitch screw pump; therefore, the center screw, or power rotor, is used to drive the two outer idler rotors directly without external timing gears. Pedestal bearings at the base support the weight of the rotors and maintain their axial position. The liquid being pumped enters the suction opening, flows through passages around the rotor housing, and through the screws from each end, in opposed streams, toward the center discharge. This eliminates unbalanced hydraulic thrust. The screw pump is used for pumping viscous fluids, usually lubricating, hydraulic, fuel oil, etc.



## RECAP ZONE .....

### Points to Remember

- In fluid mechanics, shape and size of the body are not constant and we study about statics and dynamics of flow of fluid subjected to various types of forces on it.
- The **fluid density** is the quantity of fluid contained in its unit volume. It can be expressed in three different ways—mass density, specific weight, and relative density.
- **Viscosity**,  $\mu$  is a property of a fluid, which offers resistance to shear deformation.
- In any fluid flow, layers move at different velocities and the fluid's viscosity arises from the shear stress developed between the layers that ultimately oppose any applied force.
- An **ideal fluid** has zero viscosity.
- **Shear force** is not involved in its deformation.
- An ideal fluid must be incompressible.
- In **Newtonian fluids**, a linear relationship exists between the magnitude of the applied shear stress and the resulting rate of deformation.
- **Surface tension** is the tendency of the surface of a liquid to behave like a stretched elastic membrane.
- Surface tension may also be defined as the work (in  $\text{Nm/m}^2$  or  $\text{N/m}$ ) required to create a unit surface area of the liquid.
- **Capillarity** is a phenomenon of rise or fall of the liquid surface in a small tube relative to the adjacent general level of liquid when the tube is held vertically in the liquid.
- The Bernoulli's equation is an approximate relation between pressure, velocity, and elevation, and is valid in regions of steady and incompressible flow where net frictional forces are negligible.
- **Hydraulic machines** are the devices that convert hydraulic energy into mechanical energy or mechanical energy into hydraulic energy.
- **Hydraulic turbines** are the basic prime movers which convert the hydraulic energy (in the form of pressure/kinetic energy) into mechanical energy.
- **Pump** converts mechanical energy into hydraulic energy (pressure energy).
- Pelton turbine is named after L. A. Pelton an American Engineer; it is a high head, tangential flow, and low specific speed turbine.
- Initially, **Francis turbine** was designed as a pure radial flow reaction turbine by an American Engineer James B. Francis.
- **Modern Francis turbine** is mixed flow reaction turbine.
- A **taper draft tube** is used at the outlet of the turbine to increase the head of water by the height of the draft tube.
- **Kaplan turbine** is an axial flow, low head, high specific speed, reaction type turbine.
- **Cavitation** is defined as the phenomenon of formation of vapor bubbles due to fall in pressure below its vapor pressure and sudden bursting of these bubbles in a high-pressure zone.
- **Governing** of turbines is required to control the speed of the turbine.
- **Centrifugal pump** works on the reverse of the principle of working of radial inward flow reaction turbine.
- In a **reciprocating pump**, this energy transformation is done by the reciprocating action of the piston.
- A **gear pump maintains** the flow of fluid by carrying the fluid between the teeth of two meshed gears.
- Hydraulic coupling is used to transmit the power from one shaft to another.

## Important Formulae

$$1. \quad \tau = \mu \frac{\partial u}{\partial y}$$

$$2. \quad \mu = \mu_0 \left( \frac{1}{1 + \alpha t + \beta t^2} \right) \quad \text{for liquids}$$

$$\mu = \mu_0 + \alpha t - \beta t^2 \quad \text{for gases}$$

$$3. \quad p = \frac{4\sigma}{d} \quad \text{for liquid droplets}$$

$$4. \quad p = \frac{8\sigma}{d} \quad \text{for soap bubble}$$

$$5. \quad p = \frac{2\sigma}{d} \quad \text{for liquid jet}$$

$$6. \quad h = \frac{4\sigma \cos \theta}{\rho \times g \times d}$$

$$7. \quad \frac{p}{\rho g} + \frac{V^2}{2g} + z = \text{constant}$$

$$8. \quad \eta_h \text{ (Hydraulic efficiency)} = \frac{\text{Power delivered to the runner}}{\text{Power available at the inlet of the turbine}}$$

$$9. \quad H_{net} = H_g - h_f$$

$$\text{where, } h_f \text{ (head loss due to friction)} = \frac{4fLv^2}{2gD}$$

$f$  is coefficient of friction,

$L$  is length of penstock,

$v$  is velocity of water, and

$D$  is diameter of penstock.

$$10. \quad \eta_{mech} \text{ (Mechanical efficiency)} = \frac{\text{Power produced at the shaft of the turbine}}{\text{Power supplied to the runner}}$$

$$11. \quad \eta_v \text{ (Volumetric efficiency)} = \frac{\text{Actual volume of water striking the runner}}{\text{Volume of the water supplied to the turbine}}$$

$$12. \quad \eta_o = \frac{\text{Power available at the shaft of the turbine}}{\text{Power supplied at the inlet of the turbine}}$$

$$13. \quad \text{For Pelton Turbine, } \eta_h = \frac{2[V_1 + (V_1 - u)\cos\phi - u] \times u}{V_1^2} = \frac{2(V_1 - u)[1 + \cos\phi] \times u}{V_1^2}$$

14. For maximum efficiency,

$$u = \frac{V_1}{2} \text{ and } \eta_h = \frac{1 + \cos\phi}{2}$$

15. Efficiency of draft tube,  $\eta_d = \frac{\left(\frac{V_1^2}{2g} - \frac{V_2^2}{2g}\right) - h_f}{\left(\frac{V_1^2}{2g}\right)}$

16. For radial flow reaction Turbine:

The work done per second per unit weight of water

$$= \frac{\rho Q [V_{\omega 1} u_1 \pm V_{\omega 2} u_2]}{\rho Q g} = \frac{[V_{\omega 1} u_1 \pm V_{\omega 2} u_2]}{g}$$

17. For Francis Turbine  $V_{\omega 2} = 0$ :

Work done per second per unit weight of water =  $\frac{V_{\omega 1} u_1}{g}$

$$\eta_h = \frac{V_{\omega 1} u_1}{g \times H}; \text{ Speed ratio} = \frac{V_1}{\sqrt{2gH}} \quad (= 0.65 \text{ to } 0.85); \text{ Flow ratio} = \frac{V_{f1}}{\sqrt{2gH}} \quad (= 0.5)$$

18. For Kaplan Turbine:

Peripheral velocity at inlet and outlet are equal,  $u = u_1 = u_2 = \frac{\pi D_o N}{60}$

Discharge through runner,  $Q = \frac{\pi}{4} (D_o^2 - D_b^2) \times V_{f1}$

19. For Centrifugal pump:

$$W = - \left[ \frac{V_{\omega 1} u_1 - V_{\omega 2} u_2}{g} \right] = \frac{V_{\omega 2} u_2}{g}$$

Work done by impeller on water per second =  $\rho Q V_{\omega 2} u_2$

20. Manometric Efficiency ( $\eta_{man}$ ) =  $\frac{\text{Manometric head}}{\text{Head imparted by impeller on water}} = \frac{gH_m}{V_{\omega 2} u_2}$

Mechanical efficiency ( $\eta_{mech}$ ) =  $\frac{\text{Power at the impeller}}{\text{Power at the shaft}} = \rho Q \left( \frac{V_{\omega 2} u_2}{1000} \right) / \text{Shaft power}$

Overall efficiency ( $\eta_o$ ) =  $\eta_{man} \times \eta_{mech} = \left( \frac{\rho Q \times H_m}{1000} \right) / \text{Shaft power}$

21. Minimum speed required for starting a centrifugal pump

$$N = \frac{120 \times \eta_{\max} \times V_{\omega 2} \times D_2}{\pi (D_2^2 - D_1^2)}$$

22. In multistage centrifugal pump

23. For high head, pumps are coupled in series;

24. For high discharge, pumps are coupled in parallel

Specific speed,

$$i. N_s = \frac{N \sqrt{Q}}{H_m^{3/4}}$$

25. Priming of centrifugal pump: Priming of a centrifugal pump is defined as the operation in which the suction pipe, casing of the pump and a part of the delivery pipe up to the delivery valve is completely filled with water and air from these parts of the pump is removed.

For Reciprocating pump:

- 26.

$$Q = \frac{ALN}{60} \quad \text{for single acting reciprocating pump}$$

$$= \frac{2ALN}{60} \quad \text{for double acting reciprocating pump}$$

$$\text{Power developed, } P = \frac{ALN}{60} \times \rho g \times (h_s + h_d) \quad \text{for single acting reciprocating pump}$$

$$= \frac{2ALN}{60} \times \rho g \times (h_s + h_d) \quad \text{for double acting reciprocating pump}$$

$$h_{as} = \frac{l_s}{g} \times \frac{A}{a_s} \times \omega^2 r \cos \theta$$

$$h_{ad} = \frac{l_d}{g} \times \frac{A}{a_d} \times \omega^2 r \cos \theta$$

where  $A$  is area of piston and  $a_s$  and  $a_d$  area as of suction and delivery pipes, respectively.

$$h_{fs} = \frac{4fl_s}{2gd_s} \left( \frac{A}{a_s} \omega r \sin \theta \right)^2, \quad \text{and}$$

$$h_{fd} = \frac{4fl_d}{2gd_d} \left( \frac{A}{a_d} \omega r \sin \theta \right)^2$$

At  $\theta = 90^\circ$  head loss due to friction will be maximum and at  $\theta = 0^\circ$  head loss will be zero.

27. Work done by pump for a single acting reciprocating pump

$$W = \frac{\rho g ALN}{60} \left( h_s + h_d + \frac{2}{3}h_{fs} + \frac{2}{3}h_{fd} \right)$$

28. Work done by pump for a double acting reciprocating pump

$$W = \frac{2\rho g ALN}{60} \left( h_s + h_d + \frac{2}{3}h_{fs} + \frac{2}{3}h_{fd} \right)$$

29. Work done by reciprocating pump with air vessels fitted to suction and delivery pipes

$$W = \frac{\rho g ALN}{60} [h_s + h_d + h_{fs} + h_{fd}]$$

30. Work done by reciprocating pump with air vessels fitted to suction and delivery pipes

$$W = \frac{\rho g ALN}{60} [h_s + h_d + h_{fs} + h_{fd}]$$



## REVIEW ZONE

### Multiple-choice Questions

- Fluid is a substance that:
  - Cannot be subjected to shear force
  - Always expands until it fills any container
  - Has the same shear stress at a point regardless of its motion
  - Cannot remain at rest under action of any shear force
- A fluid is said to be ideal, if it is:
  - Incompressible
  - Inviscous
  - Viscous and incompressible
  - Inviscous and incompressible
- The volumetric change of the fluid caused by a resistance is known as:
  - Volumetric strain
  - Compressibility
  - Adhesion
  - Cohesion
- Surface tension:
  - Acts in the plane of the interface normal to any line in the surface
  - Is also known as capillarity
  - Is a function of the curvature of the interface
  - Decrease with fall in temperature
- The stress-strain relation of the Newtonian fluid is:
  - Linear
  - Parabolic
  - Hyperbolic
  - None of these
- Unit of surface tension is:
  - Energy per unit area
  - Force per unit length
  - Both
  - None of these
- Capillary action is due to the:
  - Surface tension
  - Cohesion of the liquid
  - Adhesion of the liquid molecules and the molecules on the surface of a solid
  - All of the above
- The rise or fall of head 'h' in a capillary tube of diameter 'd' and liquid surface tension ' $\sigma$ ' and specific weight 'w' is equal to:
  - $\frac{4\sigma}{wd}$
  - $\frac{4d\sigma}{w}$
  - $\frac{4wd}{\sigma}$
  - None of these
- Cavitation will begin when:
  - The pressure at any location reaches an absolute pressure equal to the saturated vapor pressure of the liquid
  - Pressure becomes more than the critical pressure
  - Flow is increased
  - Pressure is increased
- Bernoulli's theorem deals with the conservation of:
  - Mass
  - Force
  - Momentum
  - Energy
- Euler's equation in the differential form for motion of liquids is given by:
  - $\frac{dp}{\rho} - gdz + vdv = 0$
  - $\frac{dp}{\rho} + gdz + vdv = 0$
  - $\frac{dp}{\rho} - gdz - vdv = 0$
  - $\frac{dp}{\rho} + gdz - vdv = 0$
- A fluid which obeys  $\mu = \frac{\tau}{du/dy}$ :
  - Real fluid
  - Perfect fluid
  - Newtonian fluid
  - None of these
- The speed of turbine and discharge through turbine are proportional to:
  - Head, H
  - $\sqrt{H}$
  - $H^2$
  - $H^{3/2}$
- Specific speed of a turbine depends on:
  - Speed, power, and discharge
  - Discharge and power
  - Speed and head
  - Speed, power, and head
- An impulse turbine:
  - Operates submerged
  - Requires draft tube
  - Is not exposed to atmosphere
  - Operates by initial complete conversion to kinetic energy

16. A Pelton wheel is:  
 (a) Tangential flow turbine  
 (b) Axial flow turbine  
 (c) Radial flow turbine  
 (d) Mixed flow turbine
17. Pelton wheels are used for minimum heads of:  
 (a) 20 m (b) 100 m  
 (c) 125 m (d) 180 m
18. The ratio of width of bucket for a Pelton wheel to the diameter of jet is of the order of:  
 (a) 15 (b) 14  
 (c) 13 (d) 12
19. Impulse turbine is used for:  
 (a) Low head (b) High head  
 (c) Medium head (d) High flow
20. If  $\alpha$  is the angle of blade tip at outlet, then maximum hydraulic efficiency of an impulse turbine is:  
 (a)  $\frac{1 + \cos \alpha}{2}$  (b)  $\frac{1 - \cos \alpha}{2}$   
 (c)  $\frac{1 + \tan \alpha}{2}$  (d)  $\frac{1 - \tan \alpha}{2}$
21. Francis turbine is best suited for:  
 (a) Medium head application (24 to 180 m)  
 (b) Low head installation (less than 30 m)  
 (c) High head installation (more than 180 m)  
 (d) None of these
22. In reaction turbine, draft tube is used:  
 (a) To transport water downstream without eddies  
 (b) To convert the kinetic energy to pressure energy by a gradual expansion of the flow cross-section  
 (c) For safety of turbine  
 (d) To increase flow rate
23. Francis, Kaplan and propeller turbines fall under the category of:  
 (a) Impulse turbine  
 (b) Reaction turbine  
 (c) Axial-flow turbine  
 (d) Mixed flow turbine
24. For pumping viscous oil, the pump used is:  
 (a) Centrifugal pump  
 (b) Reciprocating pump  
 (c) Screw pump  
 (d) None of these
25. The work requirement of a reciprocating pump with increase in acceleration head:  
 (a) Increases (b) Decreases  
 (c) Remains same (d) None of these
26. To avoid cavitation in centrifugal pumps:  
 (a) Suction pressure should be low  
 (b) Delivery pressure should be low  
 (c) Suction pressure should be high  
 (d) Delivery pressure should be high
27. Overall efficiency of centrifugal pump is equal to:  
 (a) Volumetric efficiency  $\times$  manometric efficiency  $\times$  mechanical efficiency  
 (b) Volumetric efficiency/manometric efficiency  $\times$  mechanical efficiency  
 (c) Volumetric efficiency  $\times$  manometric efficiency/mechanical efficiency  
 (d) Volumetric efficiency/manometric efficiency/mechanical efficiency
28. The action of centrifugal pump is that of a:  
 (a) Reaction turbine  
 (b) Impulse turbine  
 (c) Reverse of reaction turbine  
 (d) None of these
29. In double acting reciprocating pump compared to single acting reciprocating pump will have nearly:  
 (a) Double efficiency (b) Double head  
 (c) Double flow (d) Double weight
30. Specific speed of pump is:  
 (a)  $\frac{N\sqrt{Q}}{H^{3/4}}$  (b)  $\frac{N\sqrt{P}}{H^{5/4}}$   
 (c)  $\frac{N\sqrt{Q}}{H^{2/3}}$  (d)  $\frac{N\sqrt{Q}}{H^{3/2}}$
31. Power required to drive a centrifugal pump is proportional to:  
 (a) Impeller diameter (D)  
 (b)  $D^2$   
 (c)  $D^3$   
 (d)  $D^4$
32. Power required to drive a centrifugal pump is proportional to:  
 (a) Speed (N) (b)  $N^2$   
 (c)  $N^3$  (d)  $N^4$

## Answers

1. (d)	2. (d)	3. (b)	4. (a)	5. (a).	6. (c)
7. (d)	8. (a)	9. (a)	10. (d)	11. (b)	12. (c)
13. (a)	14. (d)	15. (d)	16. (a)	17. (d)	18. (d)
19. (b)	20. (a)	21. (a)	22. (b)	23. (b)	24. (c)
25. (c)	26. (c)	27. (a)	28. (c)	29. (c)	30. (a)
31. (d)	32. (c)				

## Theory Questions

- What do you understand by fluid mechanics? How does it differ from mechanics of solid or mechanics of the rigid body?
- Classify the fluids based on their properties.
- Derive the Bernoulli's equation.
- Derive the rise and fall of capillary action in a tube.
- Derive an equation for pressure on a submerged body in a fluid.
- What do you mean by a hydraulic turbine? How do you classify the hydraulic turbines?
- Explain the working of Pelton turbine with a neat sketch.
- Discuss the governing of Pelton turbine.
- Derive the expression for work done and mechanical efficiency of Pelton turbines.
- How does a hydraulic turbine differ from the hydraulic pump?
- What are the different types of the efficiency of a turbine? Define each.
- Draw inlet and outlet velocity triangle for Pelton turbine and find expression for hydraulic efficiency.
- Establish a relationship between jet velocity and bucket velocity for maximum efficiency of Pelton turbine?
- What is the basis of turbine selection at a particular place?
- Define velocity coefficient, speed ratio, flow ratio, and jet ratio.
- What are the ranges of specific speed and head of Pelton, Francis, and Kaplan turbines?
- What is a draft tube? Why is it used in a reaction turbine? Describe with a neat sketch.
- What is the centrifugal pump? How is it different from Francis turbine?
- \*19. Explain the working of a centrifugal pump with a neat sketch.
- Differentiate between the volute and vortex casing of a centrifugal pump.
- Explain different types of the efficiency of the centrifugal pump.
- Find the expression for the work done by impeller of a centrifugal pump on water per second per unit weight of water.
- \*23. What is priming? Why is it required in a centrifugal pump?
- What is the reciprocating pump? Explain its working with a neat sketch.
- What are the slip and coefficient of discharge?
- What is air vessel? What are the functions of air vessel?
- Draw indicator diagram and show acceleration head, friction head on the diagram.
- \*28. Explain the working of the double acting reciprocating pump and bucket pump with a neat sketch.
- \*29. What is the function of the pump? Classify the pumps. Explain with a sketch the working of the single acting reciprocating piston pump.

\* indicates that similar questions have appeared in various university examinations.



- \*30. Explain the working principle of vane pump with a neat sketch?
- \*31. What is the range of specific speed for Pelton, Francis, and Kaplan turbine?
- \*32. Explain how a hydraulic reaction turbine differs from a hydraulic impulse turbine.
- \*33. Discuss and draw the constructional details of Pelton turbine.
- \*34. With the help of neat sketch, explain the working of a Francis turbine.
- \*35. Explain the principle and working of reaction turbine.
- \*36. Define radial flow, axial flow, and mixed flow with respect to water turbine.
- \*37. How are water turbines classified?
- \*38. Sketch and explain the working of a Kaplan turbine.

## Numerical Problems

- The dynamic viscosity of lubricating oil used between shaft and sleeve is 12 poise. The diameter of the shaft, which rotates at 240 rpm, is 0.5 m. The sleeve length is 120 mm. Calculate the power lost if the thickness of oil film is 2.5 mm.
- The surface tension of water in contact with air at ambient temperature is 0.12 N/m. The pressure inside the water droplet is 0.02 N/cm<sup>2</sup> greater than the outside pressure. Calculate the diameter of the water droplet.
- Find the surface tension in a soap bubble of 60 mm diameter when the inside pressure is 5 N/m<sup>2</sup> above atmospheric pressure.
- Calculate the capillary rise in a glass tube of diameter 1.8 mm when immersed vertically in: (i) water and (ii) mercury. Assume surface tension for water as 0.07 and for mercury as 0.5 in contact with air. The specific gravity for mercury is 13.6 and angle of contact is 130°.
- The water is flowing through a pipe having diameters 32 cm and 18 cm at two sections 1 and 2, respectively. The rate of flow through the pipe is 100 L/sec. Section 1 is 8 m above the datum and section 2 is 8 m above the datum. If the pressure at section 1 is 5 bar, find the intensity of pressure at section 2.
- A penstock supplies water to Pelton turbine with a head of 80 m. One-third of head is lost in penstock due to friction. The flow rate of water from the nozzle is 2.5 m<sup>3</sup>/sec. The deflection angle of the jet is 165°. Speed ratio,  $C_u = 0.45$  and  $C_v = 0.95$ . Calculate power developed by the turbine and its hydraulic efficiency.
- A Pelton wheel is to be designed with following specifications:  
Shaft power = 10,000 kW, Head = 500 m, Speed = 500 rpm, Overall efficiency = 85%, jet diameter is one-tenth of wheel diameter. Determine: (i) the wheel diameter, (ii) the number of jets required, and (iii) diameter of the jet. Assume  $C_v = 0.98$  and  $C_u = 0.46$ .
- A Francis turbine working under a head of 10 m. The overall efficiency is 75% and power required to produce 180 kW. The peripheral and radial velocities at inlet are  $0.3\sqrt{2gH}$  and  $0.96\sqrt{2gH}$ , respectively. The wheel runs at 200 rpm and hydraulic efficiency of the turbine is 84%. Assuming radial discharge, find: (i) the guide blade angle, (ii) vane angle at inlet, (iii) diameter of the wheel at the inlet, and (iv) width of the wheel at the inlet.
- An inward flow reaction turbine rotates at 420 rpm. The wheel vanes are radial at the inlet and the inner diameter of the wheel is one-third of the outer diameter. The constant velocity of flow in the wheel is 2.8 m/sec. Water enters the wheel at an angle of 150° to the tangent at the wheel at the inlet. The width of the wheel at the inlet is 85 mm and area of flow blocked by vane is 2.5% of the gross area of flow at the inlet. Assuming radial discharge, find: (i) head available, (ii) vane angle at the outlet, (iii) the outer and inner diameter of the wheel, and (iv) the theoretical water power developed by the wheel.
- A Kaplan turbine is working under a head of 18 m. The hub diameter is 0.25 times the runner

\* indicates that similar questions have appeared in various university examinations.

diameter. The rpm of the turbine is 550. Runner angle at the outlet is  $15^\circ$  and flow ratio is 0.6. Calculate: (i) diameter of runner and (ii) discharge rate of water.

11. A Kaplan turbine is designed to develop 8,000 kW shaft power. The head available is 12 m. Assuming speed ratio as 2.1, flow ratio as 0.6, overall efficiency as 80%, and diameter of the boss as one-third of the diameter of runner. Find the diameter of runner and its speed.
12. A conical draft tube having inlet and outlet diameters 2.5 m and 3.0 m discharges water at the outlet with a velocity of 5 m/sec. The total length of the draft tube is 10 m out of which 3 m of the length of the draft tubes immersed in water. If atmospheric pressure head is 10.3 m of water and loss of head due to friction in the draft tube is equal to 0.2 times of velocity head at the outlet of the tube. Find: (i) pressure head at inlet, and (ii) Efficiency of draft tubes.
13. A centrifugal pump running at 2,000 rpm has internal and external impeller diameter of 250 mm and 350 mm, respectively. The vane angles of the impeller at inlet and outlet are  $25^\circ$  and  $30^\circ$ , respectively. If water enters the impeller radially and velocity of flow remains constant. Determine the work done by the impeller per unit weight of water.
14. A centrifugal pump having an internal and external diameter of impeller 150 mm and 450 mm, respectively, is running at 1,000 rpm. It has a constant velocity of flow of 5 m/sec and discharges through the pump is  $0.04 \text{ m}^3/\text{sec}$ . The diameters of suction and delivery pipes are 100 and 80 mm, respectively and suction and delivery heads are 8 and 20 m of water, respectively. If outlet vane angle is  $30^\circ$  and power required to drive the pump is 18 kW. Determine: (i) vane angle at the inlet, (ii) overall efficiency of the pump, and (iii) manometric efficiency of the pump.
15. Following data of a centrifugal pump are given as: Diameter at inlet = 0.4 m; Diameter at outlet = 1.0 m; Speed = 400 rpm; Flow rate = 2000 liters/sec; Vane exit angle =  $30^\circ$ ; Velocity of flow = 3 m/sec; head = 10 m. Find the least speed to start the pump and Manometric efficiency.
16. A double acting reciprocating pump has a piston of 400 mm diameter and piston rod of 40 mm diameter. Stroke length is 300 mm and speed is 60 rpm. The suction and discharge heads are 8 m and 18 m, respectively. Determine: (i) the force required to run the pump during in and out strokes, (ii) quantity of water in  $\text{m}^3/\text{sec}$  raised by the pump, and (iii) power required to run the pump.
17. A single acting reciprocating pump running at 50 rpm delivers  $0.10 \text{ m}^3/\text{sec}$  of water. The diameter of the piston is 600 mm and the stroke length is 500 mm. Determine: (i) the theoretical discharge, (ii) percentage slip, and (iii) coefficient of discharge.

## Learning Objectives

*By the end of this chapter, the student will be able:*

- To understand the different types of air compression process
- To demonstrate the single stage and multi-stage reciprocating air compressors
- To calculate the power required to run the compressors
- To describe the working of axial and centrifugal compressors

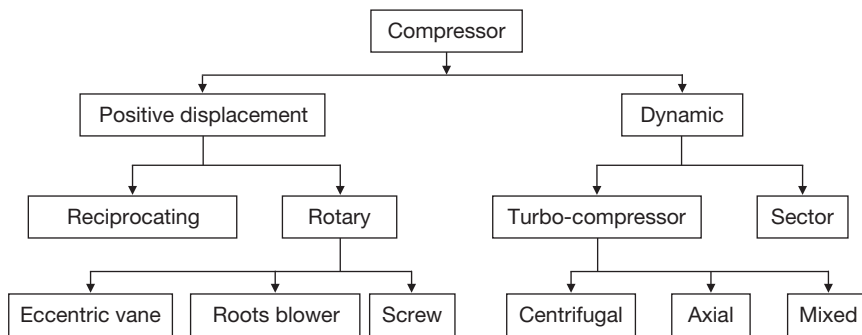
### 10.1 ► INTRODUCTION

The function of the compressor is to compress the gases and vapors from low pressure to high pressure. According to the second law of thermodynamics, this is only possible when work is done on the system, i.e., on the gas or vapor. Compressors have wide industrial and domestic applications such as compression of refrigerants in refrigerators and air conditioning plants, compression of air to fill the air in the wheel of automobiles, use of compressed fluids in nonconventional machining processes, etc.

### 10.2 ► CLASSIFICATION OF COMPRESSORS

Compressors can be classified on the basis of a range of pressures, capacity, pressure ratio, and design and principle of operations.

- (i) On the basis of the pressure range, compressors can be classified as:
  - Low-pressure compressor (below 10 bars)
  - Medium pressure compressor (10-80 bars)



**FIGURE 10.1**

Classification of Compressors

High-pressure compressor (80-1000 bars)

Hyper compressor (above 1000 bars)

(ii) On the basis of capacity, compressors can be classified as:

Low capacity compressor (below  $0.15 \text{ m}^3/\text{sec.}$ )

Medium capacity compressor ( $0.15$  to  $5 \text{ m}^3/\text{sec.}$ )

High capacity compressor (above  $5 \text{ m}^3/\text{sec.}$ )

(iii) On the basis of pressure ratio, compressors can be classified as:

Fan (Pressure ratio below 1.1)

Blower (Pressure ratio between 1.1 to 2.3)

Compressor (Pressure ratio above 2.3)

(iv) On the basis of design and principle of operations, compressors can be classified as shown in Figure 10.1:

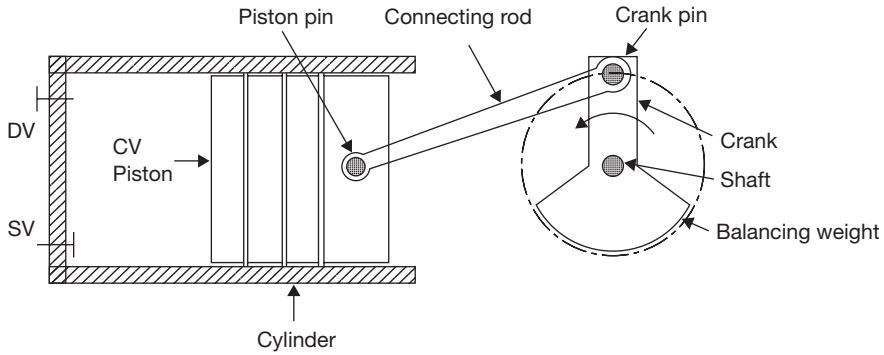
**Positive displacement compressor:** In this compressor, the pressure is raised by decreasing the volume of gas, i.e., positive displacement of gas.

**Dynamic compressor:** In this compressor, the kinetic energy imparted to the gas by the rotation of the rotor is converted into pressure energy partly in the rotor and rest in the diffuser.

### 10.3 ► RECIPROCATING COMPRESSORS

In these compressors, the gas volume decreases and pressure increases due to the action of one or more reciprocating piston moving axially in one or more cylinders. It may be single acting or double acting, single cylinder or multi-cylinder, and single stage or multi-stage compressors.

Figure 10.2 shows the schematic of a reciprocating compressor. Reciprocating compressors consist of a piston moving back and forth in a cylinder, with suction and discharge valves to achieve suction and compression of the gas. Its construction and working are very similar to a two-stroke engine, as suction and compression of the gas are completed

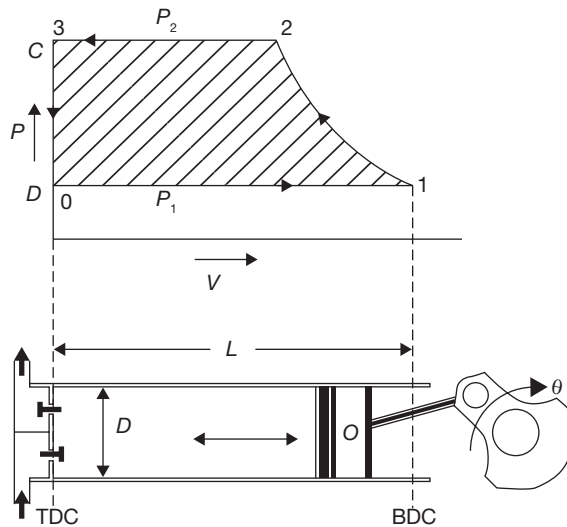


**FIGURE 10.2**

Schematic Diagram of Reciprocating Compressor

in one revolution of the crank. The suction (inlet) and the discharge (outlet) valves open and close due to pressure differences between the cylinder and inlet or outlet manifolds respectively. The pressure in the inlet manifold is equal to or slightly less than the atmospheric pressure. Similarly, the pressure in the outlet manifold is equal to the pressure of the compressor at the end of compression. The purpose of the manifolds is to provide stable inlet and outlet pressures for the smooth operation of the valves and also provide a space for mounting the valves.

Working principle of ideal reciprocating compressors is diagrammatically shown in Figure 10.3.



**FIGURE 10.3**

Ideal Reciprocating Compressor

An ideal reciprocating compressor has following assumptions:

- (i) There is no clearance volume in the cylinder.
- (ii) Working fluid behaves like a perfect gas.
- (iii) There is no friction loss.
- (iv) There is no loss during the passing of the fluid through valves.

**Process 0-1:** This is an isobaric suction process, during which the piston moves from the Top Dead Center (TDC) to the Bottom Dead Center (BDC). The suction valve remains open during this process and gas at a constant pressure  $P_1$  flows into the cylinder.

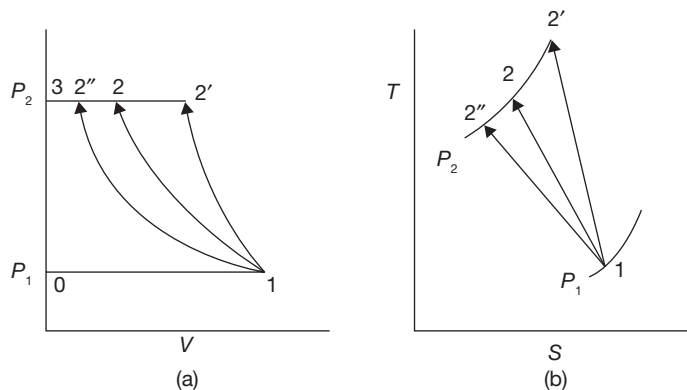
**Process 1-2:** This is an isentropic compression process. During this process, the piston moves from BDC towards TDC. Both the suction and discharge valves remain closed during the process and the pressure of the gas increases from  $P_1$  to  $P_2$ . Various types of compression process in reciprocating compressors are shown in  $P$ - $V$  and  $T$ - $S$  diagrams in Figure 10.4.

Isentropic compression	1-2'	$\Upsilon = 1.4$ for air
Polytropic compression	1-2	$\Upsilon = 1.25$ for air
Isothermal compression	1-2''	Temperature remains constant.

**Process 2-3:** This is an isobaric discharge process. During this process, the suction valve remains closed and the discharge valve opens. Gas at a constant  $P_2$  is expelled from the compressor as the piston moves to TDC.

### 10.3.1 Polytropic Compression

Area 0-1-2-3 represents the net work done when the compression follows the polytropic law.



**FIGURE 10.4**

(a)  $P$ - $V$  and  $T$ - $S$  Diagrams for Isentropic, Polytropic, and Isothermal Compression, and (b) Isentropic Compression

Net work on air per cycle = area 0-1-2-3 = Work done during compression (1-2) + work done during air delivery (2-3) – work done during suction (0-1).

$$\begin{aligned}
 &= \frac{P_2 V_2 - P_1 V_1}{n-1} + P_2 V_2 - P_1 V_1 = \frac{n}{n-1} (P_2 V_2 - P_1 V_1) \\
 &= \frac{n}{n-1} P_1 V_1 \left( \frac{T_2}{T_1} - 1 \right) = \frac{n}{n-1} P_1 V_1 \left[ \left( \frac{P_2}{P_1} \right)^{\frac{n-1}{n}} - 1 \right] \\
 W &= \frac{nm}{n-1} RT_1 \left[ \left( \frac{P_2}{P_1} \right)^{\frac{n-1}{n}} - 1 \right]
 \end{aligned}$$

Similarly, for **Isentropic compression**

$$W = \frac{\gamma m}{\gamma - 1} RT_1 \left[ \left( \frac{P_2}{P_1} \right)^{\frac{\gamma-1}{\gamma}} - 1 \right]$$

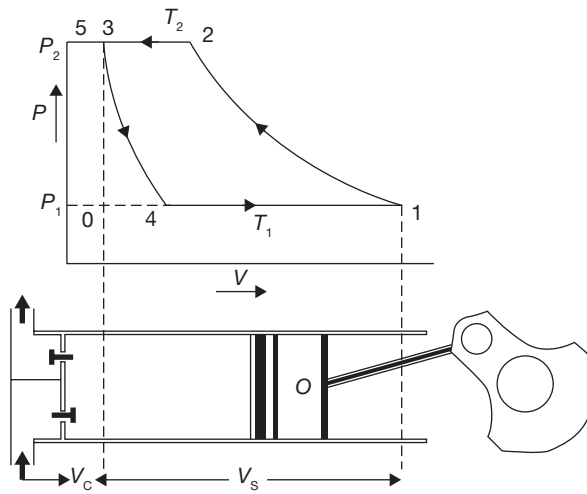
### 10.3.2 Isothermal Compression

$$\begin{aligned}
 W &= \text{area } 0-1-2''-3 \\
 &= P_2 V_2'' + P_1 V_1 \log_e \frac{V_1}{V_2''} - P_1 V_1; \quad \text{But, } P_2 V_2'' = P_1 V_1 \\
 W &= P_1 V_1 \log_e \frac{V_1}{V_2''} = P_1 V_1 \log_e \frac{P_2''}{P_1}
 \end{aligned}$$

In isothermal compression work done is minimum and is maximum for adiabatic compression.

### 10.3.3 Effect of Clearance on Work Done

$$\begin{aligned}
 \text{Work input per cycle} &= \text{area}(1-2-3-4) \quad (\text{Refer Figure 10.5}) \\
 &= \text{area}(0-1-2-5) - \text{area}(3-4-0-5) \\
 &= \frac{n}{n-1} m_1 R (T_2 - T_1) - \frac{n}{n-1} m_3 R (T_3 - T_4)
 \end{aligned}$$

**FIGURE 10.5**

Reciprocating Compressor with Clearance Volume

### 10.3.4 Volumetric Efficiency

The volumetric efficiency of a compressor is the ratio of actual free air delivered to the displacement of the compressor.

$$\eta_v = \frac{V_1 - V_4}{V_s} = \frac{V_s + V_c - V_4}{V_s} = 1 + \frac{V_c}{V_s} - \frac{V_4}{V_s} \quad (\text{Refer Figure 10.5}) \quad (10.1)$$

$$P_3 V_3^n = P_4 V_4^n \quad \Rightarrow \quad V_4 = \left( \frac{P_3}{P_4} \right)^{\frac{1}{n}} V_3$$

But,  $P_3 = P_2, P_4 = P_1$ , and  $V_3 = V_c$

$$V_4 = \left( \frac{P_2}{P_1} \right)^{\frac{1}{n}} V_c$$

Substituting the value of  $V_4$  in Equation (10.1), we get

$$\eta_v = 1 + \frac{V_c}{V_s} - \left( \frac{P_2}{P_1} \right)^{\frac{1}{n}} \frac{V_c}{V_s} = 1 + \frac{V_c}{V_s} \left( 1 - \left( \frac{P_2}{P_1} \right)^{\frac{1}{n}} \right) = 1 + \epsilon \left( 1 - r^{\frac{1}{n}} \right)$$

Where  $\epsilon$  is clearance ratio  $\left( \frac{V_c}{V_s} \right)$  and  $r$  is pressure ratio  $\left( \frac{P_2}{P_1} \right)$ .



**EXAMPLE 10.1**

A single cylinder, single acting air compressor has a cylinder diameter of 150 mm and stroke of 300 mm. It draws air into the cylinder at a pressure of 1 bar and temperature 27°C. This air is then compressed adiabatically to a pressure of 8 bars if the compressor runs at a speed of 120 rpm, find: (i) mass of air compressed per cycle, (ii) work required per cycle, and (iii) power required to drive the compressor. Neglect the clearance volume and take  $R = 0.287 \text{ kJ/kgK}$ .

**SOLUTION**

$$(i) \text{ Mass of air compressed} = \frac{P_1 V_1}{RT_1}$$

$$V_1 = L \times A = 0.3 \text{ m} \times \frac{\pi}{4} \times (0.15 \text{ m})^2 = 0.00529 \text{ m}^3$$

$$\therefore m = \frac{1 \times 10^5 \text{ N/m}^2 \times 0.00529 \text{ m}^3}{0.287 \times 10^3 \text{ J/kgK} \times 300 \text{ K}} = \mathbf{0.00615 \text{ kg per cycle}}$$

$$(ii) \text{ Work required per cycle, } W = \frac{\gamma m}{\gamma - 1} RT_1 \left[ \left( \frac{P_2}{P_1} \right)^{\frac{\gamma - 1}{\gamma}} - 1 \right]$$

$$= \frac{1.4 \times 0.00615 \text{ kg}}{1.4 - 1} \times 0.287 \text{ kJ/kgK} \times 300 \text{ K} \left[ \left( \frac{8 \text{ bar}}{1 \text{ bar}} \right)^{\frac{1.4 - 1}{1.4}} - 1 \right]$$

$$= \mathbf{1.503 \text{ kJ per cycle}}$$

$$(iii) \text{ Power required to run the compressor} = \text{Work required per cycle} \times \text{Cycle per sec}$$

$$= 1.503 \text{ kJ} \times \frac{120 \text{ cycles}}{60 \text{ sec}} = \mathbf{3.006 \text{ kW}}$$

**EXAMPLE 10.2**

A single stage reciprocating compressor is required to compress 1 kg of air from 1 bar to 5 bars. The initial temperature of the air is 27°C. Calculate work for isothermal, isentropic, and Polytropic compression for  $n = 1.25$ .

**SOLUTION**

$$W_{\text{isothermal}} = P_1 V_1 \log_e \frac{V_1}{V_2} = P_1 V_1 \log_e \frac{P_2}{P_1} = mRT_1 \log_e \frac{P_2}{P_1}$$

$$= 1 \text{ kg} \times 0.287 \text{ kJ/kgK} \times 300 \text{ K} \log_e \frac{5 \text{ bar}}{1 \text{ bar}} = \mathbf{138.57 \text{ kJ per cycle}}$$

$$\begin{aligned}
 W_{\text{isentropic}} &= \frac{\gamma m}{\gamma - 1} RT_1 \left[ \left( \frac{P_2}{P_1} \right)^{\frac{\gamma-1}{\gamma}} - 1 \right] = \frac{1.4 \times 1 \text{ kg}}{1.4 - 1} \times 0.287 \text{ kJ/kgK} \times 300 \text{ K} \left[ \left( \frac{5 \text{ bar}}{1 \text{ bar}} \right)^{\frac{1.4-1}{1.4}} - 1 \right] \\
 &= 175.92 \text{ kJ per cycle} \\
 W_{\text{polytropic}} &= \frac{nm}{n-1} RT_1 \left[ \left( \frac{P_2}{P_1} \right)^{\frac{n-1}{n}} - 1 \right] = \frac{1.25 \times 1 \text{ kg}}{1.25 - 1} \times 0.287 \text{ kJ/kgK} \times 300 \text{ K} \left[ \left( \frac{5 \text{ bar}}{1 \text{ bar}} \right)^{\frac{1.25-1}{1.25}} - 1 \right] \\
 &= 163.47 \text{ kJ per cycle}
 \end{aligned}$$

### 10.3.5 Multistage Compression

A number of stages required depends on the pressure to be developed in the compressor. Normally, following relationships are used with pressure and number of stages.

- ▶ Single stage compression is used for delivery pressures up to 5.6 kgf/cm<sup>2</sup>.
- ▶ Two stage compressions are used for delivery pressures up to 5.6 to 35 kgf/cm<sup>2</sup>.
- ▶ Three stage compressions are used for delivery pressures up to 35 to 84 kgf/cm<sup>2</sup>.

#### *Advantages of multistage compression*

- ▶ There is little chance of lubrication troubles due to lowering of maximum temperature.
- ▶ Leakage loss is minimized.
- ▶ There is a gain in volumetric efficiency.
- ▶ More uniform torque with the small size of the flywheel can be generated.

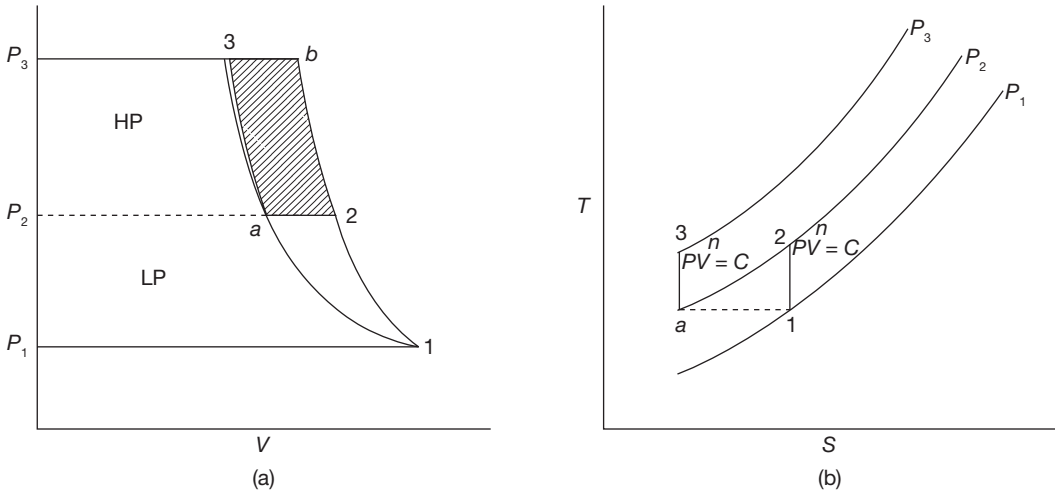
#### *Assumption in multistage compression*

The following assumptions are usually made in the calculation of work done in multistage compression:

- ▶ For each stage, pressures during suction and delivery remain constant.
- ▶ The index ( $n$ ) in polytropic law is same in each stage of compression.
- ▶ Intercooling in each stage is done at constant pressure.
- ▶ Low pressure and high-pressure cylinders handle the same mass of air.
- ▶ There is no interstage pressure drop, i.e., exhaust pressure of one stage equals the suction pressure of the next stage.

### 10.3.6 Work Done in Multistage Compression

$P$ - $V$  and  $T$ - $S$  diagrams for multistage compression are shown in Figure 10.6.



**FIGURE 10.6**

P-V and T-S Diagrams for Multistage Compressor

$$\text{Work input in L.P. cylinder} = \frac{n}{n-1} P_1 V_1 \left[ \left( \frac{P_2}{P_1} \right)^{\frac{n-1}{n}} - 1 \right]$$

$$\text{Work input in H.P. cylinder} = \frac{n}{n-1} P_2 V_a \left[ \left( \frac{P_3}{P_2} \right)^{\frac{n-1}{n}} - 1 \right]$$

$$\text{Total work input} = \frac{n}{n-1} P_1 V_1 \left[ \left( \frac{P_2}{P_1} \right)^{\frac{n-1}{n}} - 1 \right] + \frac{n}{n-1} P_2 V_a \left[ \left( \frac{P_3}{P_2} \right)^{\frac{n-1}{n}} - 1 \right]$$

$$W = \frac{n}{n-1} R T_1 \left[ \left( \frac{P_2}{P_1} \right)^{\frac{n-1}{n}} - 1 \right] + \frac{n}{n-1} R T_a \left[ \left( \frac{P_3}{P_2} \right)^{\frac{n-1}{n}} - 1 \right]$$

$$= \frac{n}{n-1} R \left[ T_1 \left( \left( \frac{P_2}{P_1} \right)^{\frac{n-1}{n}} - 1 \right) + T_a \left( \left( \frac{P_3}{P_2} \right)^{\frac{n-1}{n}} - 1 \right) \right]$$

If  $P_1$ ,  $T_1$  and delivery pressure  $P_3$  are fixed, the optimum value of the intermediate pressure  $P_2$  for minimum work can be obtained by setting the derivative  $dW/dP_2 = 0$ .

$$\frac{dW}{dP_2} = \frac{n}{n-1} R \left[ T_1 \times \frac{n-1}{n} \left( \frac{P_2}{P_1} \right)^{-\frac{1}{n}} \times \frac{1}{P_1} + T_a \times \frac{n-1}{n} \left( \frac{P_3}{P_2} \right)^{-\frac{1}{n}} \times \left( -\frac{P_3}{P_2^2} \right) \right] = 0$$

$$T_1 \left( \frac{P_2}{P_1} \right)^{-\frac{1}{n}} \times \frac{1}{P_1} = T_a \left( \frac{P_3}{P_2} \right)^{-\frac{1}{n}} \times \left( -\frac{P_3}{P_2^2} \right)$$

or, 
$$\frac{P_2}{P_1} = \sqrt[n]{\left( \frac{T_a}{T_1} \right)^{n-1} \frac{P_3}{P_1}}$$

For perfect cooling,  $T_a = T_1$

$$P_2 = \sqrt[n]{P_3 P_1}$$

In general, if there are  $N$  stages, the pressure ratio for each stage will be given by

$$\frac{P_2}{P_1} = \frac{P_3}{P_2} = \frac{P_4}{P_3} = \dots = \frac{P_{N+1}}{P_N}$$

and 
$$W = \frac{Nn}{n-1} RT_1 \left[ \left( \frac{P_{N+1}}{P_1} \right)^{\frac{n-1}{Nn}} - 1 \right]$$

*Heat rejected during compression process*

$$Q = \left[ C_p + C_v \left( \frac{\gamma - n}{n - 1} \right) \right] (T_2 - T_1)$$

*Mean Effective Pressure,  $p_m$*

$$p_m = \frac{60 \times \text{Indicator power (kW)}}{1000 \times A(\text{m}^2) \times L(\text{m}) \times N(\text{rpm})} \text{ N/m}^2 \text{ for single acting reciprocating compressor}$$

$$p_m = \frac{60 \times \text{Indicator power (kW)}}{1000 \times A(\text{m}^2) \times 2L(\text{m}) \times N(\text{rpm})} \text{ N/m}^2 \text{ for double acting reciprocating compressor}$$

### EXAMPLE 10.3

A single stage single acting air compressor has intake pressure 1 bar and delivery pressure 12 bar. The compression and expansion follow the law  $pV^{1.3} = \text{constant}$ . The piston speed and rotations of the shaft are 180 m/min and 350 rpm, respectively. Indicated power is 30 kW and volumetric efficiency is 92%. Determine the bore and stroke.

**SOLUTION**

The indicating power of single acting reciprocating compressor is

$$i_p = \frac{p_m \times 10^5 \times L \times A \times N}{1000 \times 60} \text{ kW}$$

$$\text{Also, } p_m = \frac{\text{Work done per cycle}}{\text{Stroke volume} \times \text{Volumetric efficiency}} = \frac{\frac{n}{n-1} P_1 V_1 \left[ \left( \frac{P_2}{P_1} \right)^{\frac{n-1}{n}} - 1 \right]}{V_1 \times \eta_v}$$

$$= \frac{\frac{1.3}{1.3-1} \times 1 \text{ bar} \times \left[ 12^{\left( \frac{1.3-1}{1.3} \right)} - 1 \right]}{0.92} = 3.95 \text{ bar}$$

Average piston speed =  $L \times N = 180 \text{ m/min}$ ; for single acting reciprocating pump

$$i_p = 30 \times 10^3 \text{ W} = \frac{3.95 \times 10^5 \text{ N/m}^2 \times A \times 180 \text{ m/min}}{60} \Rightarrow A = 0.0253 \text{ m}^2$$

$$A = 0.0253 \text{ m}^2 = \frac{\pi}{4} D^2 \Rightarrow D = \sqrt{\frac{4 \times 0.0253 \text{ m}^2}{\pi}} = 0.179 \text{ m} = 17.9 \text{ cm}$$

$$L = \frac{180 \text{ m/min}}{350 \text{ rpm}} = 0.514 \text{ m} = 51.4 \text{ cm}$$

**EXAMPLE 10.4**

An air compressor has eight stages of an equal pressure ratio of 1.35. The flow rate through the compressor and the overall efficiency are 50 kg/sec and 90%, respectively. If the air enters compressors at a pressure of 1.0 bar and temperature of 313 K. Determine: state of air at the exit of the compressor.

**SOLUTION**

$$\frac{p_2}{p_1} = \frac{p_3}{p_2} = \frac{p_4}{p_3} = \frac{p_5}{p_4} = \frac{p_6}{p_5} = \frac{p_7}{p_6} = \frac{p_8}{p_7} = \frac{p_9}{p_8} = 1.35$$

$$p_1 = 1 \text{ bar}$$

$$p_2 = 1.35 \times p_1 = 1.35 \text{ bar}$$

$$P_3 = 1.35 \times P_2 = 1.822 \text{ bar}$$

$$P_4 = 1.35 \times P_3 = 2.46 \text{ bar}$$

$$P_5 = 1.35 \times P_4 = 3.32 \text{ bar}$$

$$P_6 = 1.35 \times P_5 = 4.482 \text{ bar}$$

$$P_7 = 1.35 \times P_6 = 6.05 \text{ bar}$$

$$P_8 = 1.35 \times P_7 = 8.167 \text{ bar}$$

$$P_9 = 1.35 \times P_8 = 11.02 \text{ bar}$$

### EXAMPLE 10.5

A double acting, single cylinder, reciprocating air compressor has a piston displacement of  $0.015 \text{ m}^3$  per revolution, operates at 500 rpm and has a 5% clearance. The air is received at 1 bar and delivered at 6 bars. The compression and expansion are polytropic with  $n = 1.3$ . Determine: (i) the volumetric efficiency, (ii) the power required, and (iii) the heat transferred and its direction during compression if inlet temperature of the air is 293K.

### SOLUTION

$V = 0.015 \text{ m}^3$  per revolution;  $N = 500 \text{ rpm}$ ;  $\epsilon = 5\%$ ;  $n = 1.3$ ;  $P_1 = 1 \text{ bar}$ ; and  $P_2 = 6 \text{ bar}$ .

$$(i) \quad \eta_v = 1 + \epsilon - \epsilon \left( \frac{P_2}{P_1} \right)^{\frac{1}{n}} = 1 + 0.05 - 0.05(6 \text{ bar} / 1 \text{ bar})^{\frac{1}{1.3}} = 0.85 \text{ or } 85\%.$$

$$(ii) \quad \text{Power required} = \frac{n}{n-1} \times P_1 \times V_{\text{actual stroke}} \left[ \left( \frac{P_2}{P_1} \right)^{\frac{n-1}{n}} - 1 \right]$$

Where  $V_{\text{actual stroke}} = V_s \times 2 \times N \times \eta_v = 0.015 \text{ m}^3/\text{rev} \times 2 \times 500 \text{ rpm} \times 0.85 = 12.75 \text{ m}^3/\text{min}$ .

$$\text{Now power required} = \frac{1.3}{1.3-1} \times 1 \times 10^2 \text{ N/m}^2 \times 12.75 \text{ m}^3/\text{min} \left[ \left( \frac{6 \text{ bar}}{1 \text{ bar}} \right)^{\frac{0.3}{1.3}} - 1 \right] = 2835 \text{ kJ/min}.$$

$$= \frac{2835 \text{ kJ/min}}{60} = 47.2 \text{ kW}$$

$$(iii) \quad m = \frac{P_1 V_{\text{actual stroke}}}{RT_1} = \frac{1 \times 10^2 \times 12.75}{0.287 \times 293} = 15.6 \text{ kg/min.}$$

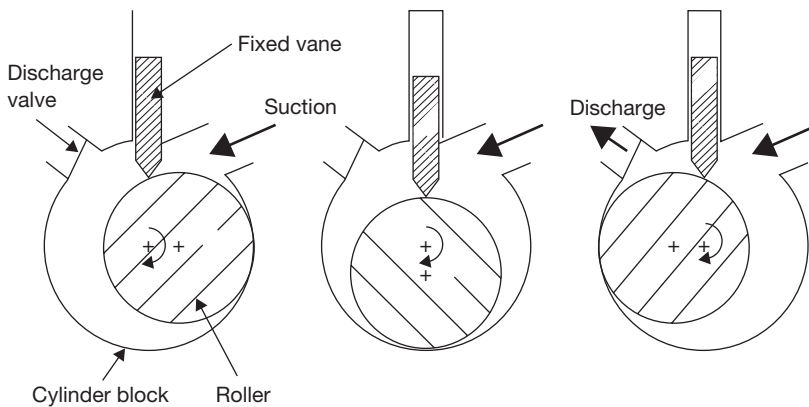
Heat rejected during compression.

$$\begin{aligned} Q &= m \left[ C_p + C_v \left( \frac{\gamma - n}{n - 1} \right) \right] (T_2 - T_1) = \left[ C_p + C_v \left( \frac{\gamma - n}{n - 1} \right) \right] T_1 \left( \left( \frac{P_2}{P_1} \right)^{\frac{n-1}{n}} - 1 \right) \\ &= 15.6 \text{ kg/min} \left[ 1.005 \text{ kJ/kgK} + 0.718 \text{ kJ/kgK} \left( \frac{1.4 - 1.3}{1.3 - 1} \right) \right] \times 298 \text{ K} \left( \left( \frac{6 \text{ bar}}{1 \text{ bar}} \right)^{\frac{0.3}{1.3}} - 1 \right) \\ &= 2950.116 \text{ kJ / min} \end{aligned}$$

## 10.4 ► ROTARY COMPRESSORS

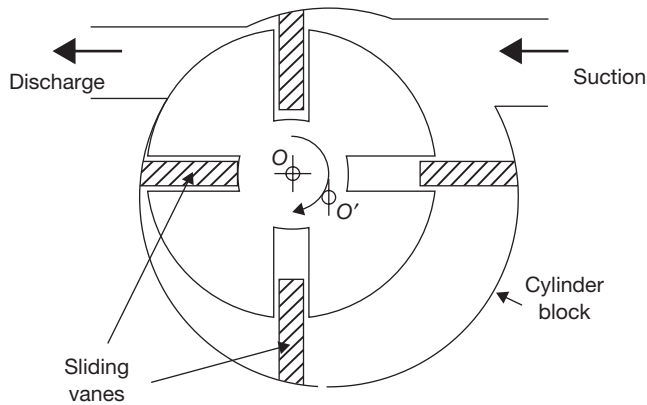
### 10.4.1 Fixed Vane Type Compressors

These compressors belong to the category of positive displacement type as compression is achieved by reducing the volume of the gas. In this type of compressors, the rotating shaft of the roller has its axis of rotation that matches with the centerline of the cylinder; however, it is eccentric with respect to the roller as shown in Figure 10.7. This eccentricity



**FIGURE 10.7**

Fixed Vane Type Rotary Compressor



**FIGURE 10.8**

Multiple Vane Type Rotary Compressor

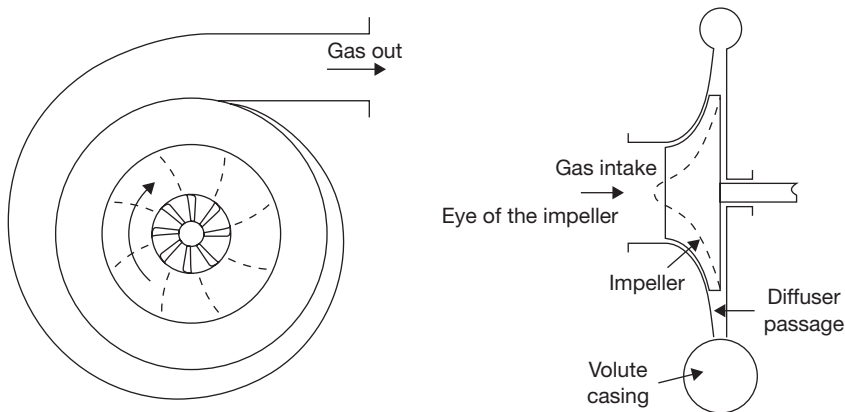
of the shaft with respect to the roller creates suction and compression of the gas. A single vane or blade is positioned in the non-rotating cylindrical block. The rotating motion of the roller causes a reciprocating motion of the single vane. This type of compressor does not require a suction valve but requires a discharge valve. The leakage is controlled through hydrodynamic sealing and matching between the mating components. The effectiveness of the sealing depends on the clearance, compressor speed, surface finish and oil viscosity. Close tolerances and good surface finishing are required to minimize internal leakage.

### 10.4.2 Multiple Vane Type Rotary Compressors

In multiple vane type compressors, the axis of rotation coincides with the center of the roller (O), however, it is eccentric with respect to the center of the cylinder (O') as shown in Figure 10.8. The rotor consists of a number of slots with sliding vanes. During the running of the compressor, the sliding vanes are held against the cylinder due to centrifugal forces. The number of compression strokes produced in one revolution of the rotor is equal to the number of sliding vanes, thus a 4-vane compressor produces 4 compression strokes in one rotation.

In these compressors, sealing is required between the vanes and cylinder, between the vanes and the slots on the rotor and between the rotor and the end plate. However, since pressure difference across each slot is only a fraction of the total pressure difference, the sealing is not as critical as in fixed vane type compressor. This type of compressor does not require suction or discharge valves, however, check valves are used on discharge side to prevent reverse rotation during off-time due to the pressure difference.



**FIGURE 10.9**

Centrifugal Compressor

## 10.5 ► CENTRIFUGAL COMPRESSORS

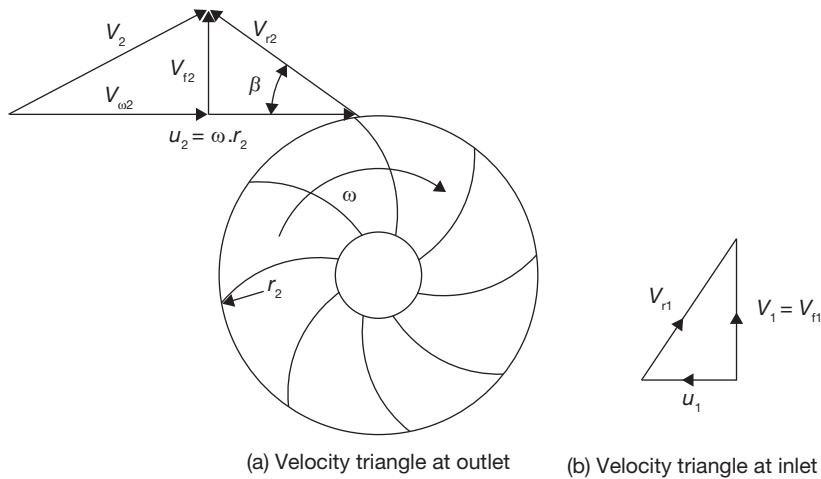
In these compressors, the pressure rise takes place due to the continuous conversion of angular momentum imparted to the gas by a high-speed impeller into static pressure. Unlike reciprocating compressors, centrifugal compressors are steady-flow devices hence they are subjected to less vibration and noise. Figure 10.9 shows the working principle of a centrifugal compressor. As shown in the Figure, low-pressure gas enters the compressor through the eye of the impeller. The impeller consists of a number of blades, which form flow passages for gas.

From the eye, the gas enters the flow passages formed by the impeller blades, which rotate at very high speed. As the gas flows through the blade passages towards the tip of the impeller, it gains momentum and its static pressure also increases. From the tip of the impeller, the gas flows into a stationary diffuser. In the diffuser, the gas is decelerated and as a result, the dynamic pressure drop is converted into static pressure rise, thus further increase in the static pressure. The gas from the diffuser enters the volute casing where further conversion of velocity into static pressure takes place due to the divergent shape of the volute. Finally, the pressurized gas leaves the compressor from the volute casing. The velocity triangle for the centrifugal compressor is shown in Figure 10.10.

Here,

- $V$  = absolute velocity of gas
- $u$  = blade velocity
- $V_r$  = relative velocity
- $V_\omega$  = whirl component of absolute velocity
- $V_f$  = flow or normal component of absolute velocity

Further, suffix 1 and 2 represent the conditions at inlet and outlet of the impeller.

**FIGURE 10.10**

Velocity Diagram at the Outlet of the Impeller of a Centrifugal Compressor

For inlet velocity diagram, it has been assumed that gas enters the impeller eye in an axial direction, i.e., the whirl component of absolute velocity,  $V_{\omega 1}$  is zero. Flow component of absolute velocity,  $V_{f1} = V_1$  (Figure 10.10 b)

In general, we consider the flow of a gas through a rotor of any shape, the rate of change of angular momentum is given by  $(V_{\omega 2}r_2 - V_{\omega 1}r_1)$  m/sec/kg

$$\begin{aligned} \text{Work done} &= (V_{\omega 2}r_2 - V_{\omega 1}r_1)\omega, \quad \text{As } V_{\omega 1} = 0 \\ &= V_{\omega 2}r_2\omega = V_{\omega 2}u_2 \text{ J/kg} \end{aligned}$$

It has been observed that for backward curved vanes ( $\beta < 90^\circ$ ), the tangential component of absolute velocity is much reduced and consequently for a given impeller speed, the impeller will have a low energy transfer. In the case of forward curved vanes ( $\beta > 90^\circ$ ), the tangential component of absolute velocity is increased and consequently, the energy transfer for forward curved vane is maximum. However, the absolute velocity at impeller outlet is also increased. The high value of the absolute velocity is not desirable as its conversion into static pressure cannot be carried out efficiently in diffuser section. Normally, backward vanes with  $\beta$  between  $20\text{--}25^\circ$  are employed except in the case where the high head is a major consideration.

## 10.6 AXIAL FLOW COMPRESSORS

In axial flow compressors, the flow proceeds throughout the compressor in a direction essentially parallel to the axis of the machine. The unit consists of an adjacent row of rotor blades and stator blades. One stage of the machine comprises a row of rotor blades followed

by a row of stator blades. For efficient operation, the blades are of aerofoil section based on aerodynamic design. The fixed blades serve the following purposes.

- ▶ To convert a part of the K.E. of the fluid into pressure energy. The conversion is achieved by diffusion process out in the diverge blade passage.
- ▶ To guide and redirect the fluid flow so that entry to the next stage is without shock.

### Surging

Surging is caused due to unsteady, periodic, and reversal flow of gas through the compressor when the compressor has to operate at less mass flow rate than a predetermined value. Thus, when flow through the compressor is less than a predetermined value, a surge or pulsation begins and air surges to and fro through the whole compressor instead of giving a stream in one direction.

### Choking

Mass flow rate reaches at a maximum value when the pressure ratio becomes unity. This generally occurs when the Mach number (ratio of gas velocity and sound velocity) corresponding to relative velocity at inlet becomes sonic. The maximum mass flow rate possible in a compressor is known as choking flow. Choking means fixed mass flow rate regardless of pressure ratio.

### Stalling

The phenomenon of reduction in lift force at higher angles of incidence is known as stalling. It is defined as an aerodynamic stall or the breakaway of the flow from the suction side of the blade aerofoil. The breakaway of flow from the suction side may be due to lesser mass flow rate than designed value or due to non-uniformity in blade profile.

## RECAP ZONE .....



### Points to Remember

- The function of the **compressor** is to compress the gases and vapors from low pressure to high pressure.
- In **positive displacement compressor**, the pressure is raised by decreasing the volume of gas, i.e., positive displacement of gas.
- In the **dynamic compressor**, the kinetic energy imparted to the gas by the rotation of the rotor is converted into pressure energy partly in the rotor and rest in the diffuser.
- In **reciprocating compressors**, the gas volume decreases and pressure increases due to the action of one or more reciprocating piston moving axially in one or more cylinders.
- In isothermal compression work done is minimum and is maximum for adiabatic compression.
- The **volumetric efficiency** of a compressor is the ratio of actual free air delivered to the displacement of the compressor.
- **Fixed van type compressors** belong to the category of positive displacement type as compression is achieved by reducing the volume of the gas.

- In these compressors, the pressure rise takes place due to the continuous conversion of angular momentum imparted to the gas by a high-speed impeller into static pressure.
- For backward curved vanes ( $\beta < 90^\circ$ ), the tangential component of absolute velocity is much reduced and consequently for a given impeller speed, the impeller will have a low energy transfer.
- For forward curved vanes ( $\beta > 90^\circ$ ), the tangential component of absolute velocity is increased and consequently, the energy transfer for forward curved vane is maximum.
- In **axial flow compressors**, the flow proceeds throughout the compressor in a direction essentially parallel to the axis of the machine.
- **Surging** is caused due to unsteady, periodic, and reversal flow of gas through the compressor when the compressor has to operate at less mass flow rate than a predetermined value.
- **Choking** occurs when mass flow rate reaches at a maximum value when the pressure ratio becomes unity. This generally occurs when the Mach number (ratio of gas velocity and sound velocity) corresponding to relative velocity at inlet becomes sonic.
- The phenomenon of reduction in lift force at higher angles of incidence is known as stalling.

## Important Formulae

1. Work done in polytropic compression in reciprocating compressor: 
$$W = \frac{nm}{n-1} RT_1 \left[ \left( \frac{P_2}{P_1} \right)^{\frac{n-1}{n}} - 1 \right]$$
2. Work done in isentropic compression in reciprocating compressor: 
$$W = \frac{\gamma m}{\gamma-1} RT_1 \left[ \left( \frac{P_2}{P_1} \right)^{\frac{\gamma-1}{\gamma}} - 1 \right]$$
3. Work done in isothermal compression in reciprocating compressor: 
$$W = P_1 V_1 \log_e \frac{V_1}{V_2} = P_1 V_1 \log_e \frac{P_2''}{P_1}$$
4. Effect of clearance on work done: Work input per cycle = 
$$\frac{n}{n-1} m_1 R (T_2 - T_1) - \frac{n}{n-1} m_3 R (T_3 - T_4)$$
5. Volumetric efficiency: 
$$\eta_v = 1 + \frac{V_c}{V_s} - \left( \frac{P_2}{P_1} \right)^{\frac{1}{n}} \frac{V_c}{V_s} = 1 + \frac{V_c}{V_s} \left( 1 - \left( \frac{P_2}{P_1} \right)^{\frac{1}{n}} \right) = 1 + \epsilon \left( 1 - r^n \right)$$
6. Work done in multistage compression: 
$$W = \frac{Nn}{n-1} RT_1 \left[ \left( \frac{P_{N+1}}{P_1} \right)^{\frac{n-1}{Nn}} - 1 \right]$$
  
For perfect cooling,  $T_a = T_1$   
$$P_2 = \sqrt[n]{P_3 P_1}$$
7. Heat rejected during compression process: 
$$Q = \left[ C_p + C_v \left( \frac{\gamma - n}{n - 1} \right) \right] (T_2 - T_1)$$

8. Mean Effective Pressure,  $p_m$ :

$$p_m = \frac{60 \times \text{Indicator power (kW)}}{1000 \times A(\text{m}^2) \times L(\text{m}) \times N(\text{rpm})} \text{N/m}^2 \text{ for single acting reciprocating compressor}$$

$$p_m = \frac{60 \times \text{Indicator power (kW)}}{1000 \times A(\text{m}^2) \times 2L(\text{m}) \times N(\text{rpm})} \text{N/m}^2 \text{ for double acting reciprocating compressor}$$

9. Work done in centrifugal compressor: Work done =  $(V_{\omega 2} r_2 - V_{\omega 1} r_1) \omega$ ; As  $V_{\omega 1} = 0$   
 $= V_{\omega 2} r_2 \omega = V_{\omega 2} u_2 \text{ J/kg}$



## REVIEW ZONE .....

### Multiple-choice Questions

- The most efficient method to compress the air is:
  - Isothermal compression
  - Adiabatic compression
  - Polytropic compression
  - None of these
- Maximum work is done in compressing air when the compression is:
  - Isothermal compression
  - Adiabatic compression
  - Polytropic compression
  - None of these
- Isothermal compression efficiency can be achieved by running the compressor:
  - At a very high speed
  - At a very slow speed
  - At an average speed
  - At zero speed
- Airplane employs the following type of compressor:
  - Reciprocating compressor
  - Centrifugal compressor
  - Axial flow compressor
  - None of these
- The ratio of work done per cycle to the swept volume in case of compressor is called:
  - Compression ratio
  - Compressor efficiency
  - Mean effective pressure
  - None of these
- Clearance volume in a cylinder should be:
  - As large as possible
  - As small as possible
  - About 50% of swept volume
  - None of these
- Clearance volume on a reciprocating compressor is required to:
  - Accommodate valves in the cylinder head
  - Provide a cushioning effect
  - Attain high volumetric efficiency
  - Provide a cushioning effect and also to avoid mechanical bang of the piston with the cylinder head
- The net work input required for compressor with increase in clearance volume:
  - Increases
  - Decreases
  - Remain same
  - None of these
- Volumetric efficiency is:
  - The ratio of stroke volume to clearance volume
  - The ratio of air actually delivered to the amount of piston displacement
  - Reciprocal of compression ratio
  - None of these
- A compressor at high altitude will draw:
  - More power
  - Less power
  - Same power
  - None of these
- The machine run by prime mover and used to increase the air pressure is known as:
  - Steam turbine
  - Gas turbine
  - Compressor
  - I.C. engines
- A compressor is used:
  - In a gas turbine plant
  - In supercharging I.C. Engines
  - In pneumatic drills
  - All of the above

13. Ratio of absolute discharge pressure to absolute inlet pressure is known as:
- Compression ratio
  - Expansion ratio
  - Compression efficiency
  - Compressor capacity
14. Compressor capacity is:
- The volume of air delivered
  - The volume of air sucked
  - Both (a) and (b)
  - None of these
15. As the compression ratio increases, the volumetric efficiency of air compressor:
- Increases
  - Decreases
  - Remain constant
  - None of these
16. In reciprocating compressor, clearance volume is provided to:
- Increase volumetric efficiency
  - Allow space for valves and to ensure that the piston does not strike the cylinder at the end of the stroke
  - Decrease the work done
  - All of these
17. The clearance volume in the compressor is kept minimum because it affects:
- Volumetric efficiency
  - Mechanical efficiency
  - Compressor efficiency
  - Isothermal efficiency
18. Ratio of isothermal horsepower to the shaft horse power to drive a compressor is known as:
- Volumetric efficiency
  - Mechanical efficiency
  - Overall isothermal efficiency
  - Adiabatic efficiency
19. If  $k$  is the clearance ratio for a reciprocating air compressor, then volumetric efficiency will be:
- $1 + k - K (P_2/P_1)^{Vn}$
  - $1 - k + K (P_2/P_1)^{Vn}$
  - $1 + k - K (P_1/P_2)^{Vn}$
  - $1 - k + K (P_1/P_2)^{Vn}$
20. The optimum intermediate pressure  $P_2$  in a two stage air compressor having  $P_1$  and  $P_3$  as suction and delivery pressures respectively is equal to:
- $(P_1 + P_2)/2$
  - $P_1 \cdot P_2 / 2$
  - $(P_1 + P_2)^{1/2}$
  - $(P_1 \cdot P_2)^{1/2}$
21. In multistage compression with intercooler, the compression obtained is:
- Isothermal
  - Adiabatic
  - Polytropic
  - None of the above
22. Compressor in which compression is achieved by a rotating vane or impeller to give the air the desired pressure is known as:
- Single stage compressor
  - Single acting compressor
  - Rotary compressor
  - Reciprocating compressor
23. In gas turbine, type of compressor used is:
- An axial flow compressor
  - A reciprocating compressor
  - A centrifugal compressor
  - All of the above
24. In centrifugal compressor, at a given pressure ratio an increase in speed causes:
- Increase in flow
  - Decrease in efficiency
  - Decrease in flow
  - Both (a) and (b)
25. In a centrifugal compressor, the pressure ratio can be increased by:
- Increasing tip speed
  - Decreasing inlet temperature
  - Both (a) and (b)
  - None of the above
26. An axial flow compressor gives optimum performance at:
- High speed
  - Low speed
  - Moderate speed
  - None of the above

## Fill in the Blanks

27. A centrifugal compressor works on principle of conversion of \_\_\_\_\_.
28. A compressor at high altitude will draw \_\_\_\_\_.
29. The ratio of outlet whirl velocity to blade velocity in case of centrifugal compressor is called \_\_\_\_\_.
30. For high-pressure compressors, \_\_\_\_\_ type of valve will be best suited.
31. The ratio of isentropic work to Euler work is known as \_\_\_\_\_.
32. Diffuser in compressor is used to \_\_\_\_\_.
33. Phenomenon of choking in compressor means \_\_\_\_\_.
34. Stalling of blades in axial flow compressor means \_\_\_\_\_.
35. Surging is the phenomenon of \_\_\_\_\_.
36. The maximum pressure ratio in single stage single cylinder reciprocating compressor is \_\_\_\_\_.

## Answers

- |   |                 |   |                          |         |         |
|---|-----------------|---|--------------------------|---------|---------|
| 1. (a)  | 2. (b)          | 3. (b)                                  | 4. (c)                   | 5. (c)  | 6. (b)  |
| 7. (d)  | 8. (c)          | 9. (b)                                  | 10. (b)                  | 11. (c) | 12. (d) |
| 13. (a)   | 14. (a)         | 15. (b)                                 | 16. (b)                  | 17. (a) | 18. (c) |
| 19. (a)   | 20. (d)         | 21. (a)                                 | 22. (c)                  | 23. (a) | 24. (d) |
| 25. (c)   | 26. (a)         | 27. Kinetic energy into pressure energy |                          |         |         |
| 28. Less power  | 29. Slip factor | 30. Propet                              | 31. Pressure coefficient |         |         |
| 32. Convert Kinetic energy into pressure energy       |                 |   |                          |         |         |
| 33. Fixed mass flow rate regardless of pressure ratio |                 |   |                          |         |         |
| 34. Air stream not able to flow the blade contour     |                 |   |                          |         |         |
| 35. Unsteady, periodic and reverse flow               |                 |   | 36. 1:5                  |         |         |

## Theory Questions

1. What is a function of the compressor? How do you classify the compressors? Explain the various basis of classification.
2. Explain the assumptions of working of the reciprocating compressor. Discuss the working of a reciprocating compressor with a neat sketch.
3. Derive the expression of work done by the compressor in isothermal compression, adiabatic compression, and polytropic compression.
4. Find the expression for volumetric efficiency of the reciprocating compressor.
5. Discuss the assumptions and advantages of multistage compression.
6. Explain the working of fixed vane type and multiple vane type compressors.
7. Explain the working principle of the centrifugal compressor.
8. Write short notes on surging, choking, and stalling.
- \*9. What is compressor?

\* indicates that similar questions have appeared in various university examinations.

- \*10. Derive an equation for work done in the case of single stage single acting reciprocating air compressor neglecting clearance.
- \*11. Why is multi-stage compression required? Write advantages of the multi-staging compression.
- \*12. Classify the air compressor. Differentiate between reciprocating compressor and rotary compressor.
- \*13. Discuss about rotary compressors and blower?

## Numerical Problems

1. A single cylinder, single acting air compressor has a cylinder diameter of 140 mm and stroke of 280 mm. It draws air into the cylinder at a pressure of 1 bar and temperature 27°C. This air is then compressed adiabatically to a pressure of 7 bars if the compressor runs at a speed of 120 rpm, find (i) mass of air compressed per cycle, (ii) work required per cycle, and (iii) power required to drive the compressor. Neglect the clearance volume and take  $R = 0.287 \text{ kJ/kgK}$ .
2. A single stage reciprocating compressor is required to compress 1 kg of air from 1 bar to 8 bars. The initial temperature of the air is 20°C. Calculate work for isothermal, isentropic, and Polytropic compression for  $n = 1.25$ .
3. A single stage single acting air compressor has intake pressure 1 bar and delivery pressure 10 bar. The compression and expansion follow the law  $pV^{1.3} = \text{constant}$ . The piston speed and rotations of the shaft are 200 m/min and 360 rpm, respectively. Indicated power is 40 kW and volumetric efficiency is 90%. Determine the bore and stroke.
4. An air compressor has eight stages of an equal pressure ratio of 1.4. The flow rate through the compressor and the overall efficiency are 40 kg/sec and 92%, respectively. If the air enters compressors at a pressure of 1.0 bar and temperature of 300 K. Determine: (i) state of air at the exit of the compressor, (ii) polytropic of small stage efficiency, and (iii) power required to drive the compressor.
5. A double acting, single cylinder, reciprocating air compressor has a piston displacement of 0.014 m<sup>3</sup> per revolution, operates at 600 rpm and has a 4% clearance. The air is received at 1 bar and delivered at 8 bars. The compression and expansion are polytropic with  $n = 1.3$ . Determine: (i) the volumetric efficiency, (ii) the power required, and (iii) the heat transferred and its direction during compression if inlet temperature of the air is 293K.
- \*6. A single stage, the single acting compressor has a bore of 170 mm and stroke of 260 mm. it runs at 130 rpm. The suction pressure is 1 bar and delivery pressure is 9 bar. Find the indicated power if compression (i) follows the law  $pV^{1.25} = \text{constant}$  and (ii) is isothermal. Also, find isothermal efficiency. Assume there is no clearance volume.
- \*7. Air enters a compressor at 0.2 Mpa and 30°C having a volume of 2 m<sup>3</sup>/kg is compressed to 1 Mpa isothermally. Calculate: (i) work down, (ii) change in I.E., and (iii) heat transferred.

\* indicates that similar questions have appeared in various university examinations.



# Centroid and Moment of Inertia

## Learning Objectives

*By the end of this chapter, the student will be able:*

- To calculate the center of gravity and centroid of various sections
- To demonstrate the theorem of parallel and perpendicular axes
- To calculate the mass moment of inertia and second moment of area for different sections

## 11.1 ► INTRODUCTION

The centroid is the mean position of elements of area. The coordinates of centroid is mean value of coordinates of all the elemental points in the area. The center of mass is the mean position of elements of mass. In a uniform gravitational field, the gravitational force acts through the center of mass. But, if the gravitational field (hypothetically) is not uniform (in the case of very large body), center of mass and center of gravity will be different. Similarly, if the mass per unit area of a shape varies, the center of mass would not coincide with the centroid. Centroid is a mathematical, geometric concept, i.e., the geometric center of a body. It can be calculated as the center of mass of an object with constant density throughout density.

## 11.2 ► DETERMINATION OF POSITION OF CENTROID OF PLANE GEOMETRIC FIGURES

### 11.2.1 Center of Gravity, Center of Mass, and Centroid of an Irregular Shape

In Figure 11.1, an irregular shape is shown for which we want to calculate the center of gravity, the center of mass and centroid. Here, our purpose is to differentiate the concepts

of these three different terms. It is assumed that the irregular shape, as shown in Figure 11.1, is of uniform thickness, density and subjected to the uniform gravitational field.

Let  $W_i$  be the weight of an element in the given body.  $W$  be the total weight of the body. Let the coordinates of the element are  $X_i, Y_i, Z_i$  and that of centroid  $G$  be  $\bar{X}, \bar{Y}$ , and  $\bar{Z}$ . Since  $W$  is the resultant of  $W_i$  forces. Therefore,

$$W \cdot \bar{X} = \sum W_i \cdot X_i \quad \text{and} \quad \bar{X} = \frac{\sum W_i \cdot X_i}{W}$$

$$W \cdot \bar{Y} = \sum W_i \cdot Y_i \quad \text{and} \quad \bar{Y} = \frac{\sum W_i \cdot Y_i}{W}$$

$$W \cdot \bar{Z} = \sum W_i \cdot Z_i \quad \text{and} \quad \bar{Z} = \frac{\sum W_i \cdot Z_i}{W}$$

Here,  $\bar{X}, \bar{Y}$ , and  $\bar{Z}$  are coordinates of the center of gravity,  $G$ . The resultant gravitational force acts through the point  $G$ .

If gravitational field be uniform, the gravitational acceleration ( $g$ ) will be same for all the points. Therefore, in of  $W_i$ , we can put  $M_i g$  and the center of mass can be expressed as:

$$M \cdot \bar{X} = \sum M_i \cdot X_i \quad \text{and} \quad \bar{X} = \frac{\sum M_i \cdot X_i}{M}$$

$$M \cdot \bar{Y} = \sum M_i \cdot Y_i \quad \text{and} \quad \bar{Y} = \frac{\sum M_i \cdot Y_i}{M}$$

$$M \cdot \bar{Z} = \sum M_i \cdot Z_i \quad \text{and} \quad \bar{Z} = \frac{\sum M_i \cdot Z_i}{M}$$

Here,  $\bar{X}, \bar{Y}$ , and  $\bar{Z}$  are coordinates of the center of mass,  $G$ . The resultant mass of the body is concentrated at the point,  $G$ .

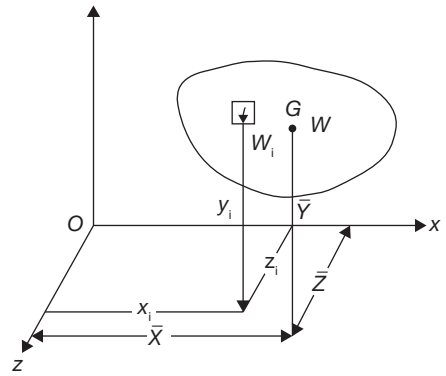
If the density of mass ( $\gamma$ ) and the thickness of the body ( $t$ ) is uniform, the mass  $M_i$  can be represented as  $\gamma \cdot A_i \cdot t$ . The centroid can be expressed as:

$$A \cdot \bar{X} = \sum A_i \cdot X_i \quad \text{and} \quad \bar{X} = \frac{\sum A_i \cdot X_i}{A}$$

$$A \cdot \bar{Y} = \sum A_i \cdot Y_i \quad \text{and} \quad \bar{Y} = \frac{\sum A_i \cdot Y_i}{A}$$

$$A \cdot \bar{Z} = \sum A_i \cdot Z_i \quad \text{and} \quad \bar{Z} = \frac{\sum A_i \cdot Z_i}{A}$$

Here,  $\bar{X}, \bar{Y}$ , and  $\bar{Z}$  are coordinates of centroid,  $G$ .



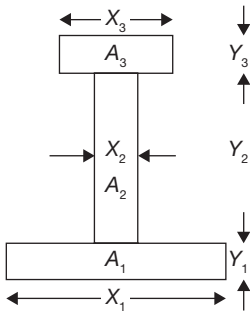
**FIGURE 11.1**

Center of Gravity, Center of Mass, and Centroid

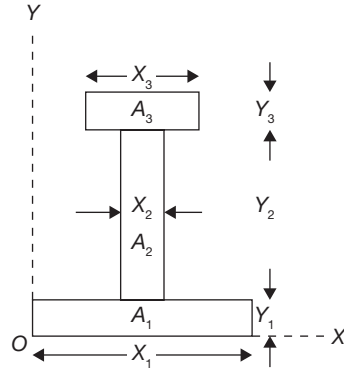
### 11.2.2 Centroid of I-section

The I-section shown in Figure 11.2 can be divided into three parts; lower part of area  $A_1$ , the middle part of area  $A_2$ , and upper part of area  $A_3$ . The lengths and widths of the all the parts of I-section are shown in the Figure 11.2. Let the  $X$  and  $Y$  coordinates be pass through origin  $O$  as shown in the Figure 11.3.

The coordinates for centroid can be calculated using the following formula:



**FIGURE 11.2**  
Centroid of I-section



**FIGURE 11.3**  
Reference Axes for I-section

$$\bar{X} = \frac{\sum A_i \cdot X_i}{\sum A_i} \quad \text{and} \quad \bar{Y} = \frac{\sum A_i \cdot Y_i}{\sum A_i}$$

$$\bar{X} = \frac{A_1 X_1/2 + A_2 X_2/2 + A_3 X_3/2}{A_1 + A_2 + A_3};$$

and 
$$\bar{Y} = \frac{A_1 Y_1/2 + A_2 (Y_1 + Y_2/2) + A_3 (Y_1 + Y_2 + Y_3/2)}{A_1 + A_2 + A_3}$$

In the case of axial symmetry about  $Y$ -axis, the distances of  $X_1/2$ ,  $X_2/2$ ,  $X_3/2$  from origin will be zero.

Hence,  $\bar{X} = 0$ .

### 11.2.3 Centroid of U-section

The U-section shown in Figure 11.4 can be divided into three parts; lower part of area  $A_1$  and two upper parts of area  $A_2$ . The lengths and widths of the all the parts of U-section are shown in the Figure 11.4. Let the  $X$  and  $Y$  coordinates be pass through origin  $o$  as shown in the Figure 11.4.

The coordinates for centroid can be calculated using the following formula:

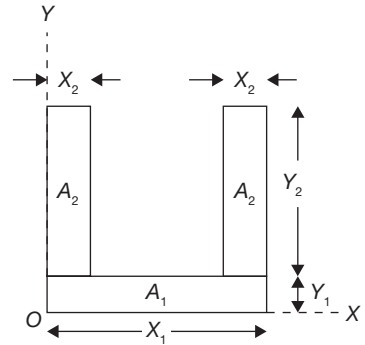
$$\bar{X} = \frac{\sum A_i \cdot X_i}{\sum A_i} \quad \text{and} \quad \bar{Y} = \frac{\sum A_i \cdot Y_i}{\sum A_i}$$

$$\bar{X} = \frac{A_1 X_1/2 + A_2 X_2/2 + A_2 (X_1 - X_2/2)}{A_1 + 2A_2};$$

and 
$$\bar{Y} = \frac{A_1 Y_1/2 + 2A_2 (Y_1 + Y_2/2)}{A_1 + 2A_2}$$

In the case of axial symmetry about Y-axis, the distances of  $X_1/2$ ,  $X_2/2$  from origin will be zero.

Hence,  $\bar{X} = 0$ .



**FIGURE 11.4**

U-section

### 11.2.4 Centroid of H-section

The H-section shown in Figure 11.5 can be divided into three parts; left and right parts of area  $A_1$  and central part of area  $A_2$ . The lengths and widths of the all the parts of H-section are shown in the Figure 11.5. Let the  $X$  and  $Y$  coordinates be pass through origin  $O$  as shown in the Figure 11.5.

The coordinates for centroid can be calculated using the following formula:

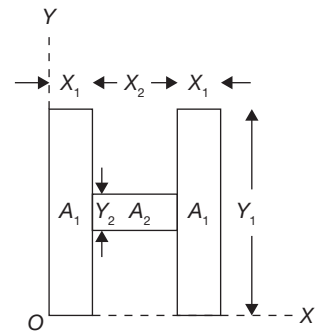
$$\bar{X} = \frac{\sum A_i \cdot X_i}{\sum A_i} \quad \text{and} \quad \bar{Y} = \frac{\sum A_i \cdot Y_i}{\sum A_i}$$

$$\bar{X} = \frac{A_1 X_1/2 + A_2 (X_1 + X_2/2) + A_1 (X_1 + X_2 + X_1/2)}{2A_1 + A_2};$$

and 
$$\bar{Y} = \frac{2A_1 Y_1/2 + A_2 (Y_1/2)}{2A_1 + A_2}$$

In the case of axial symmetry about  $Y$  axis, the distances of  $X_1/2$ ,  $X_2/2$  from origin will be zero.

Hence,  $\bar{X} = 0$ .

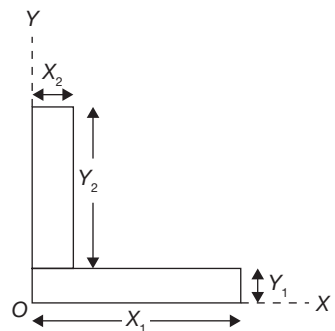


**FIGURE 11.5**

H-section

### 11.2.5 Centroid of L-section

The L-section shown in Figure 11.6 can be divided into two parts; Lower part of area  $A_1$  and upper part of area  $A_2$ . The lengths and widths of the all the parts of L-section are shown in the Figure 11.6. Let the  $X$  and  $Y$  coordinates be pass through origin  $O$  as shown in the Figure 11.6.



**FIGURE 11.6**

L-Section

The coordinates for centroid can be calculated using the following formula:

$$\bar{X} = \frac{\sum A_i \cdot X_i}{\sum A_i} \quad \text{and} \quad \bar{Y} = \frac{\sum A_i \cdot Y_i}{\sum A_i}$$

$$\bar{X} = \frac{A_1 X_1/2 + A_2 X_2/2}{A_1 + A_2}; \quad \text{and} \quad \bar{Y} = \frac{A_1 Y_1/2 + A_2 (Y_1 + Y_2/2)}{A_1 + A_2}$$

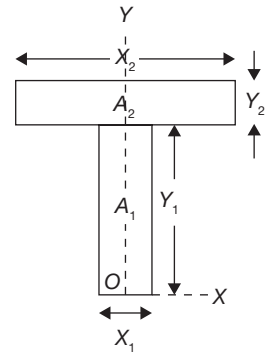
### 11.2.6 Centroid of T-section

The T-section shown in Figure 11.7 can be divided into two parts; Lower part of area  $A_1$  and upper part of area  $A_2$ . The lengths and widths of the all the parts of L-section are shown in the Figure 11.7. Let the X and Y coordinates be pass through origin 0 as shown in the Figure 11.7.

The coordinates for centroid can be calculated using the following formula:

$$\bar{X} = \frac{\sum A_i \cdot X_i}{\sum A_i} \quad \text{and} \quad \bar{Y} = \frac{\sum A_i \cdot Y_i}{\sum A_i}$$

$$\bar{X} = \frac{A_1 \times 0 + A_2 \times 0}{A_1 + A_2} = 0; \quad \text{and} \quad \bar{Y} = \frac{A_1 Y_1/2 + A_2 (Y_1 + Y_2/2)}{A_1 + A_2}$$



**FIGURE 11.7**  
T-Section

### 11.2.7 Centroid of C-section

The C-section shown in Figure 11.8 can be divided into three parts; Lower and upper parts of area  $A_1$  and middle part of area  $A_2$ . The lengths and widths of the all the parts of C-section are shown in the Figure 11.8. Let the X and Y coordinates be pass through origin 0 as shown in the Figure 11.8.

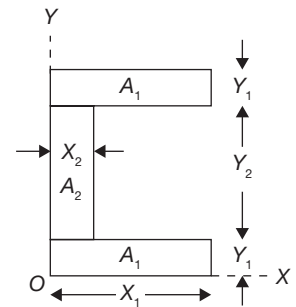
The coordinates for centroid can be calculated using the following formula:

$$\bar{X} = \frac{\sum A_i \cdot X_i}{\sum A_i} \quad \text{and} \quad \bar{Y} = \frac{\sum A_i \cdot Y_i}{\sum A_i}$$

$$\bar{X} = \frac{2A_1 X_1/2 + A_2 X_2/2}{2A_1 + A_2};$$

and

$$\bar{Y} = \frac{A_1 Y_1/2 + A_2 (Y_1 + Y_2/2) + A_1 (Y_1 + Y_2 + Y_1/2)}{2A_1 + A_2}$$



**FIGURE 11.8**  
C-Section

### 11.2.8 Centroid of Circular Arc

Centroid of an arc of a circle, as shown in Figure 11.9, has length  $L = R \cdot 2\alpha$ . Let us consider an element of the arc of length  $dL = R d\theta$ .

$$\bar{X} \cdot L = \int_{-\alpha}^{\alpha} x dL$$

$$\text{or, } \bar{X} \cdot R \cdot 2\alpha = \int_{-\alpha}^{\alpha} R \cos \theta \cdot R d\theta = R^2 [\sin \theta]_{-\alpha}^{\alpha}$$

$$= 2R^2 \sin \alpha$$

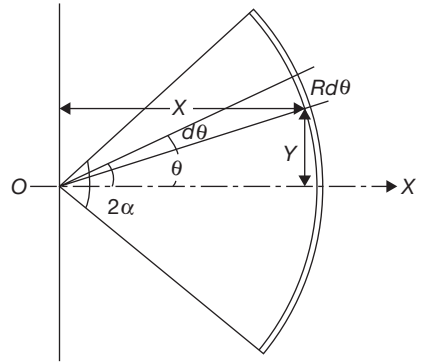
$$\text{or, } \bar{X} = \frac{2R^2 \sin \alpha}{R \cdot 2\alpha} = \frac{R \sin \alpha}{\alpha}$$

And

$$\bar{Y} \cdot L = \int_{-\alpha}^{\alpha} y dL$$

$$\text{or, } \bar{Y} \cdot R \cdot 2\alpha = \int_{-\alpha}^{\alpha} R \sin \theta \cdot R d\theta = R^2 [-\cos \theta]_{-\alpha}^{\alpha} = 0$$

$$\text{or, } \bar{Y} = 0$$



**FIGURE 11.9**

Centroid of Circular Arc

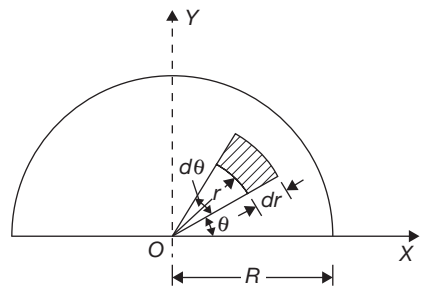
### 11.2.9 Centroid of Semicircular-section of a Disc

Considering a semicircle of radius  $R$  as shown in Figure 11.10. Due to symmetry centroid must lie on the  $y$ -axis. Let its distance from the  $x$ -axis be  $\bar{Y}$ . To find  $\bar{Y}$ , consider an element at a distance  $r$  from the center  $O$  of the semicircle, radial width  $dr$  and bound by radii at  $\theta$  and  $\theta + d\theta$ .

Area of the element  $= r d\theta dr$ .

its moment about  $x$ -axis is given by,

$$r d\theta \times dr \times r \sin \theta = r^2 \sin \theta dr d\theta$$



**FIGURE 11.10**

Centroid of Circular Section of a Disc

Total moment of area about x-axis,

$$\begin{aligned} \left[ \frac{1}{2} \pi R^2 \right] \bar{Y} &= \int_0^{\pi} \int_0^R r^2 \sin \theta dr d\theta = \int_0^{\pi} \left[ \frac{r^3}{3} \right]_0^R \sin \theta d\theta \\ &= \frac{R^3}{3} [-\cos \theta]_0^{\pi} = \frac{2R^3}{3} \end{aligned}$$

or, 
$$\bar{Y} = \frac{4R}{3\pi}$$

Thus, the centroid lies on the y-axis at a distance of  $\frac{4R}{3\pi}$  from the diametric axis.

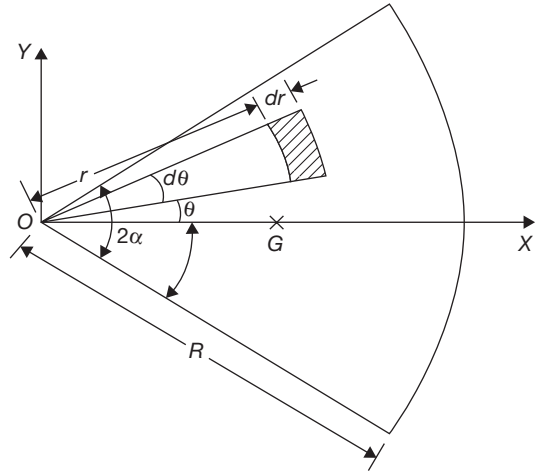
### 11.2.10 Centroid of a Sector of a Circular Disc

Consider a sector of a circular disc of angle  $2\alpha$  as shown in Figure 11.11. Due to symmetry, centroid 'G' lies on the x-axis. To find its distance from the center O, consider an elemental area as shown in the Figure 11.11.

Moment of area of the element =  $r d\theta \times dr$   
 $\times r \cos \theta = r^2 \cos \theta dr d\theta$

Total moment of area about y-axis

$$\begin{aligned} &= \int_{-\alpha}^{\alpha} \int_0^R r^2 \cos \theta dr d\theta \\ &= \left[ \frac{r^3}{3} \right]_0^R [\sin \theta]_{-\alpha}^{\alpha} = \frac{R^3}{3} 2 \sin \alpha \end{aligned}$$



**FIGURE 11.11**  
Centroid of a Sector of a Circular Disc

Total area of the sector =  $\int_{-\alpha}^{\alpha} \int_0^R r dr d\theta = \int_{-\alpha}^{\alpha} \left[ \frac{r^2}{2} \right]_0^R d\theta = \frac{R^2}{2} [\theta]_{-\alpha}^{\alpha} = R^2 \alpha$

Now, 
$$\bar{X} = \frac{\frac{2R^3}{3} \sin \alpha}{R^2 \alpha} = \frac{2R}{3\alpha} \sin \alpha$$

### 11.2.11 Centroid of a Parabola

Considering a parabolic section of height,  $h$  and base  $b$ . Now to find the centroid of this section, consider a small element of width  $dx$  at a distance of  $x$  from the origin  $O$ .

Area of the element =  $kx^2 dx$ ; where  $y = kx^2$  equation of parabola.

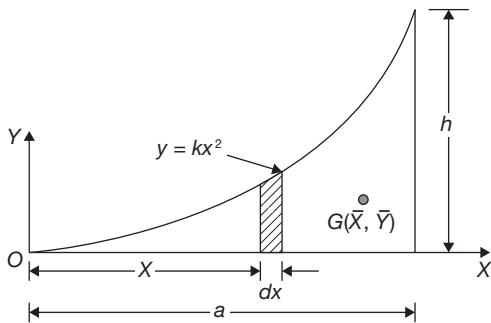
$$\text{Total area of the section} = \int_0^a kx^2 dx = \left[ \frac{kx^3}{3} \right]_0^a = \frac{ka^3}{3}$$

$$\text{Moment of area about } y \text{ - axis} = \int_0^a kx^2 dx \times x = \frac{ka^4}{4}$$

$$\text{Moment of area about } x \text{ - axis} = \int_0^a dA y / 2 = \int_0^a kx^2 dx \frac{kx^2}{2} = \int_0^a \frac{k^2 x^4}{2} dx = \frac{k^2 a^5}{10}$$

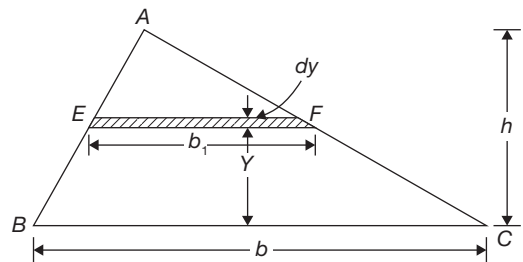
$$\bar{X} = \frac{ka^4}{4} / \frac{ka^3}{3} = \frac{3a}{4}$$

$$\bar{Y} = \frac{k^2 a^5}{10} / \frac{ka^3}{3} = \frac{3ka^2}{10} = \frac{3h}{10}$$



**FIGURE 11.12**

Centroid of a Parabolic Section



**FIGURE 11.13**

Centroid of a Triangle

### 11.2.12 Centroid of a Triangle

Consider a triangle  $ABC$  of the base,  $b$  and height,  $h$ . Let us locate the centroid of the triangle from its base. Let  $b_1$  be the width of an elemental strip of thickness  $dy$  at a distance  $y$  from the base. Since  $\triangle AEF$  and  $\triangle ABC$  are similar triangles, therefore,

$$\frac{b_1}{b} = \frac{h-y}{h} \Rightarrow b_1 = b \left( \frac{h-y}{h} \right)$$

$$\text{Area of element, } dA = b_1 dy = b \left( \frac{h-y}{h} \right) dy$$



$$\begin{aligned} \text{Moment of area, } \bar{y} \cdot \frac{bh}{2} &= \int_0^h b \left( \frac{h-y}{h} \right) y dy = \int_0^h b \left( y - \frac{y^2}{h} \right) dy \\ &= b \left[ \frac{y^2}{2} - \frac{y^3}{3h} \right]_0^h = b \left[ \frac{h^2}{2} - \frac{h^2}{3} \right] = \frac{bh^2}{6} \\ \bar{y} &= \frac{bh^2}{6} \bigg/ \frac{bh}{2} = \frac{h}{3} \end{aligned}$$

Thus the centroid of a triangle is at a distance  $h/3$  from the base and  $2h/3$  from the apex where  $h$  is the height of the triangle.

### 11.3 ► SECOND MOMENT OF AREA

The second moment of area is also known as area moment of Inertia. Consider a small lamina of area  $A$ . The second moment of area about  $x$ -axis or  $y$ -axis can be found by integrating the second moment of area of the small element of area  $dA$  of the lamina, i.e.,  $\int x^2 dA$  or  $\int y^2 dA$ . The product of the area and square of the distance of the centroid from an axis is known as area moment of Inertia. Similarly, the product of area and distance of the center of gravity of a mass from an axis is known as mass moment of inertia.

Consider a plane area which is divided into small areas  $A_1, A_2, \dots, A_n$ . Let the centroid of the small areas from a given axis be at a distance of  $r_1, r_2, \dots, r_n$  respectively. The second moment of area can be given as

$$I = A_1 r_1^2 + A_2 r_2^2 + \dots + A_n r_n^2 = \sum_i^n A_i r_i^2$$

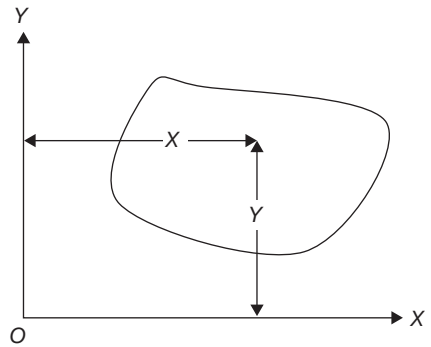
#### 11.3.1 Radius of Gyration

Radius of gyration of a body about an axis is a distance such that its square multiplied by the area gives a moment of inertia of the area about the given axis.

$$I = Ak^2 \quad \text{or,} \quad k = \sqrt{\frac{I}{A}}$$

where,

$$I = A_1 r_1^2 + A_2 r_2^2 + \dots + A_n r_n^2 = \sum_i^n A_i r_i^2$$



**FIGURE 11.14**

A Plane Area for Analysis of the Second Moment of Area

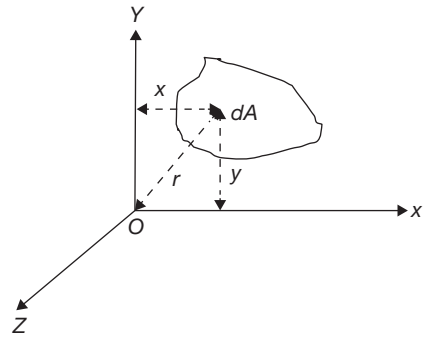
### 11.3.2 Theorem of Perpendicular Axis

Theorem of perpendicular axis states that if  $I_{XX}$  and  $I_{YY}$  be the moment of inertia of a plane section about two mutually perpendicular axes  $X-X$  and  $Y-Y$  in the plane of the section (as shown in Figure 11.15), then the moment of inertia of the section  $I_{ZZ}$  about the axis  $Z-Z$ , perpendicular to the plane and passing through the intersection of axes  $X-X$  and  $Y-Y$  is given by

$$I_{ZZ} = I_{XX} + I_{YY}$$

or, 
$$I_{ZZ} = \int x^2 dA + \int y^2 dA = \int (x^2 + y^2) dA = \int r^2 dA$$

Hence,  $I_{ZZ}$  is also known as polar moment of inertia.



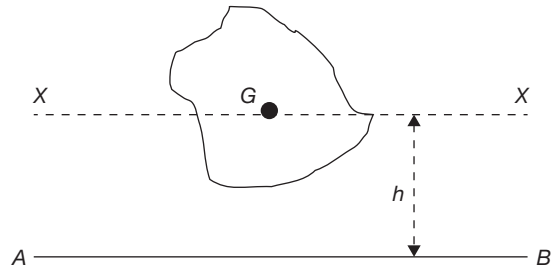
**FIGURE 11.15**

Perpendicular Axis Theorem

### 11.3.3 Theorem of Parallel Axis

Theorem of parallel axis states that if the moment of inertia of a plane area about an axis in the plane of the area through centroid be represented by  $I_G$ , then the moment of inertia of the plane about a parallel axis  $AB$  ( $I_{AB}$ ) in the plane at a distance  $h$  from the centroid of the area is given by

$$I_{AB} = I_G + Ah^2$$



**FIGURE 11.16**

Parallel Axis Theorem

### 11.3.4 Moment of Inertia from First Principle

#### A. Moment of Inertia of a Rectangle

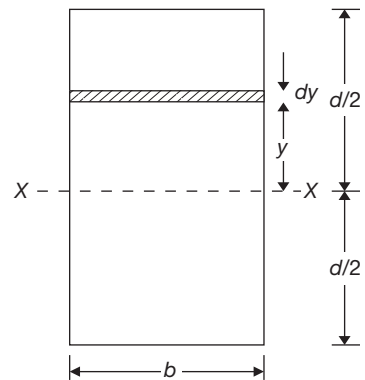
Consider an elemental strip of width  $dy$  at distance of  $y$  from a centroidal axis of a rectangle.

Moment of inertia of the strip is given by

$$I_{XX} = y^2 dA = y^2 b dy$$

Now, Moment of Inertia of entire rectangle can be given by

$$I_{XX} = \int_{-d/2}^{d/2} y^2 b dy = b \left[ \frac{y^3}{3} \right]_{-d/2}^{d/2} = \frac{bd^3}{12}$$

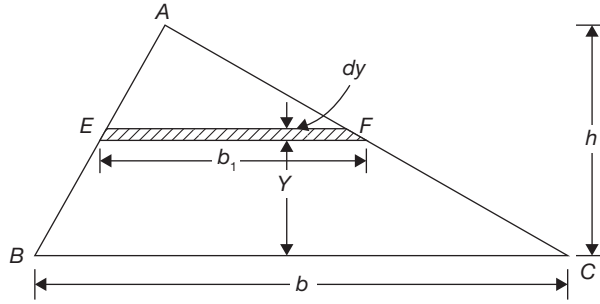


**FIGURE 11.17**

Moment of Inertia of a Rectangle about Centroidal Axis

### B. Moment of Inertia of a Triangle

Consider an elemental strip of width  $dy$  at distance of  $y$  from the base of a triangle. Moment of inertia of the strip about its base is given by



**FIGURE 11.18**

Moment of Inertia of a Triangle about its Base

$$I_{AB} = y^2 dA = y^2 b_1 dy = y^2 \frac{(h-y)}{h} \times b \times dy$$

Now, moment of inertia of entire triangle about its base

$$I_{AB} = \int_0^h y^2 \frac{(h-y)}{h} \times b \times dy = \int_0^h \left( y^2 - \frac{y^3}{h} \right) b dy = b \left[ \frac{y^3}{3} - \frac{y^4}{4h} \right]_0^h = \frac{bh^3}{12}$$

### C. Moment of Inertia of a Circular Disc

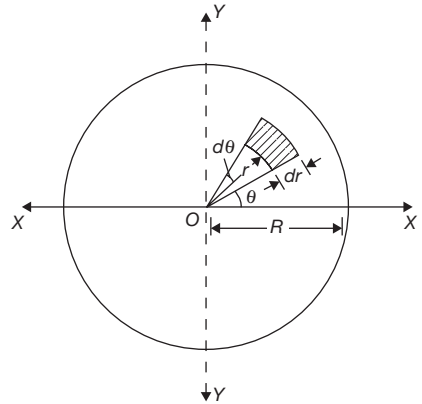
Consider an element of the arc length  $r d\theta$  and width  $dr$  of the circular disc as shown in Figure 11.19. Now, the moment of inertia of the element about diametral axis  $x-x$  is given by

$$I_{XX} = y^2 dA = (r \sin \theta)^2 d\theta dr = r^3 \sin^2 \theta d\theta dr$$

Now, moment of inertia of entire circle about diametral axis is given by

$$I_{XX} = \int_0^R \int_0^{2\pi} r^3 \sin^2 \theta d\theta dr = \int_0^R \int_0^{2\pi} r^3 \frac{(1 - \cos 2\theta)}{2} d\theta dr$$

$$= \int_0^R r^3 \left[ \theta - \frac{\sin 2\theta}{2} \right]_0^{2\pi} dr = \frac{\pi R^4}{4} = \frac{\pi d^4}{64}$$

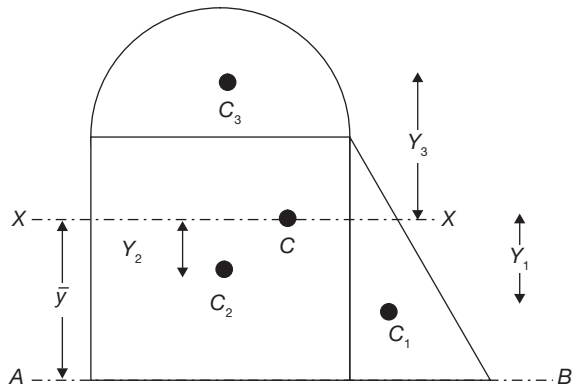


**FIGURE 11.19**

Moment of Inertia of a Circular Disc about its Diametral Axis

### 11.3.5 Moment of Inertia of Some Composite Sections

The composite section in the Figure 11.20 can be divided into three parts: triangular part of area  $A_1$ ; rectangular part of area  $A_2$ ; and semicircular part of area  $A_3$ . The individual centroid for each section is shown in the figure 11.20 as  $C_1$ ,  $C_2$ , and  $C_3$ . The centroid of the entire section is located as  $C$ . Consider the moment of inertia of the sections 1, 2, and 3 about the axes parallel to  $XX$  and passing through their individual centroid are  $I_{C_1}$ ,  $I_{C_2}$ , and  $I_{C_3}$  respectively. The moment of inertia of the entire composite section about the axis  $XX$  passing through the centroid  $C$  can be given as



**FIGURE 11.20**

Moment of Inertia of a Composite Section

$$I_{XX} = I_{C_1} + A_1 Y_1^2 + I_{C_2} + A_2 Y_2^2 + I_{C_3} + A_3 Y_3^2$$

and

$$I_{AB} = I_{XX} + A \bar{Y}^2$$

## 11.4 ► CENTER OF GRAVITY OF SOLIDS

Center of gravity of a solid is a point through which resultant line of forces passes or the line of action of gravity force passes. The difference between the center of gravity and centroid has been already explained in subsection 11.1.

## 11.5 ► MASS MOMENT OF INERTIA

Mass moment of inertia of a body about an axis is defined as the sum of the product of its elemental masses and square of their distances from the axis.

Radius of gyration of a solid body can be given as

$$I = Mk^2 \quad \text{or} \quad k = \sqrt{\frac{I}{M}}$$

where  $I$  is mass moment of inertia,  $M$  is the mass of the body, and  $k$  is the radius of gyration.

### 11.5.1 Mass Moment of Inertia of a Circular Ring

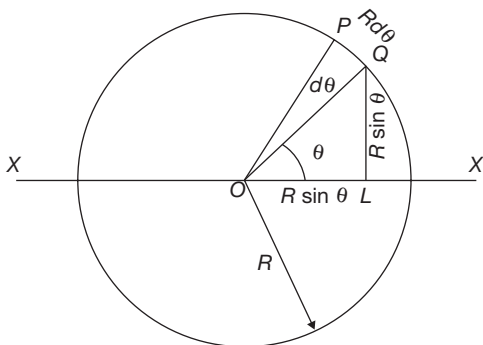
Consider a circular ring of radius  $R$  as shown in Figure 11.21. Let the mass per unit length of the ring is ' $m$ '. To find the mass moment of inertia of the ring about the diametral axis  $XX$ ,

consider an element of length  $ds = r d\theta$ ; the distance of the element from the diametral axis  $XX$  is  $R \sin\theta$ ; and mass of the element is  $mrd\theta$ .

$$\begin{aligned}
 I_{XX} &= \int_0^{2\pi} (R \sin \theta)^2 m R d\theta = m R^3 \int_0^{2\pi} (\sin^2 \theta) d\theta = m R^3 \int_0^{2\pi} \left( \frac{1 - \cos 2\theta}{2} \right) d\theta = m R^3 \left[ \theta - \frac{\cos 2\theta}{2} \right]_0^{2\pi} \\
 &= m R^3 \pi = \frac{(2\pi R m) R^2}{2} = \frac{M R^2}{2} = I_{YY} \quad (\text{due to symmetry})
 \end{aligned}$$

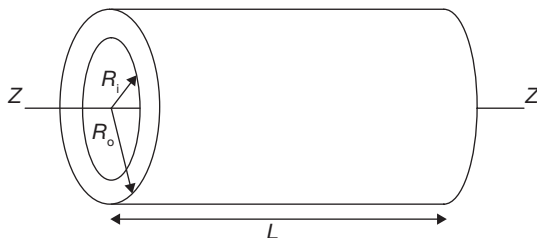
The moment of Inertia about an axis passing through the center of the circle and perpendicular to the plane of circular ring

$$I_{ZZ} = I_{XX} + I_{YY} = M R^2$$



**FIGURE 11.21**

Mass Moment of Inertia of a Circular Ring



**FIGURE 11.22**

Mass Moment of Inertia of a Hollow Cylinder

### 11.5.2 Mass Moment of Inertia of a Circular Disc

Consider an element of the disc of arc length  $r d\theta$ , width  $dr$  and thickness  $t$ .  $\rho$  is the mass density of the disc. Mass moment of inertia of the disc can be calculated as (refer Figure 11.19)

$$\begin{aligned}
 I_{XX} &= \int_0^R \int_0^{2\pi} (r \sin \theta)^2 \rho t r d\theta dr = \int_0^R \int_0^{2\pi} r^2 \sin^2 \theta \rho t r d\theta dr = \rho t \int_0^R \int_0^{2\pi} r^3 \left( \frac{1 - \cos 2\theta}{2} \right) d\theta dr \\
 &= \rho t \int_0^R \frac{r^3}{2} \left[ \theta - \frac{\sin 2\theta}{2} \right]_0^{2\pi} dr = \rho t \int_0^R \frac{r^3}{2} 2\pi dr = \rho t \pi \left[ \frac{r^4}{4} \right]_0^R
 \end{aligned}$$

$$I_{XX} = \rho t \frac{\pi R^4}{4} = \frac{(\pi R^2 \rho t) R^2}{4} = \frac{MR^2}{4}$$

$$= I_{YY} \quad (\text{due to symmetry})$$

Moment of inertia perpendicular to the plane of the circular disc

$$I_{ZZ} = I_{XX} + I_{YY} = \frac{MR^2}{2}$$

### 11.5.3 Mass Moment of Inertia of a Hollow Cylinder

Let in Figure 11.22,  $R_o$  = outer radius of cylinder;  $R_i$  = inner radius of the cylinder,  $L$  = length of cylinder;  $\rho$  = mass density of the cylinder;  $M$  = mass of the cylinder;

Consider a small elemental ring of width  $dr$  at a distance of radius  $r$  from the center of cylinder then the mass of the element,  $dm = \rho \cdot 2\pi r \cdot dr \cdot L$

Now mass moment of inertia of the element about the axis ZZ

$$I_{ZZ_{\text{element}}} = (\rho \times 2\pi r dr \times L) \times r^2$$

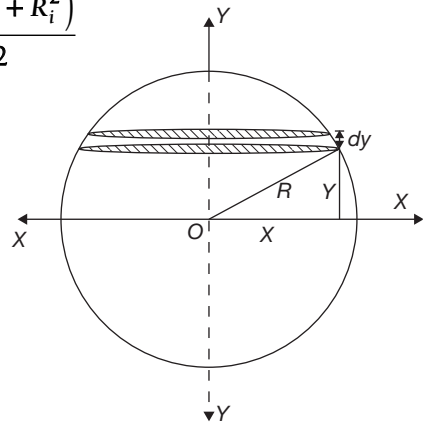
Moment of inertia of the cylinder about the axis ZZ

$$I_{ZZ} = \int_{R_i}^{R_o} (\rho \times 2\pi r dr \times L) \times r^2 = \rho \times 2\pi \times L \int_{R_i}^{R_o} r^3 dr = \rho \times 2\pi \times L \left[ \frac{r^4}{4} \right]_{R_i}^{R_o}$$

$$= \rho \times 2\pi \times L \left[ \frac{R_o^4 - R_i^4}{4} \right]$$

$$= \rho \times \pi \times L \left[ \frac{R_o^2 - R_i^2}{2} \right] \left[ R_o^2 + R_i^2 \right] = \frac{M(R_o^2 + R_i^2)}{2}$$

$$\text{Now, } I_{XX} = I_{YY} = \frac{I_{ZZ}}{2} = \frac{M(R_o^2 + R_i^2)}{4}$$



### 11.5.4 Mass Moment of Inertia of Sphere

Consider an elemental plate of thickness  $dy$  at a distance  $y$  from the diametral axis as shown in Figure 11.23. Radius of this elemental circular plate  $x$  is given by

$$x^2 = R^2 - y^2$$

Mass of the elemental plate,  $dm = \rho \pi x^2 dy = \rho \pi (R^2 - y^2) dy$

**FIGURE 11.23**

Mass Moment of Inertia of Sphere

Moment of inertia of the plate element about axis

$$\begin{aligned} YY &= \frac{1}{2} \times \rho\pi x^2 dy \times x^2 = \frac{1}{2} \times \rho\pi x^4 dy \\ &= \frac{1}{2} \times \rho\pi (R^2 - y^2)^2 dy \\ &= \frac{1}{2} \times \rho\pi (R^4 - 2R^2 y^2 + y^4) dy \end{aligned}$$

$$\begin{aligned} I_{yy} &= 2 \int_0^R \frac{1}{2} \times \rho\pi (R^4 - 2R^2 y^2 + y^4) dy = \rho\pi \left[ R^4 y - \frac{2R^2 y^3}{3} + \frac{y^5}{5} \right]_0^R \\ &= \rho\pi R^5 \left[ 1 - \frac{2}{3} + \frac{1}{5} \right] = \frac{8}{15} \rho\pi R^5 \end{aligned}$$

But, mass of sphere,  $M = \frac{4\pi R^3}{3}$

$$I_{YY} = \frac{2}{5} MR^2$$

Massmoment of inertia of hemisphere about the axis ZZ,

$$I_{ZZ} = \frac{1}{5} MR^2$$

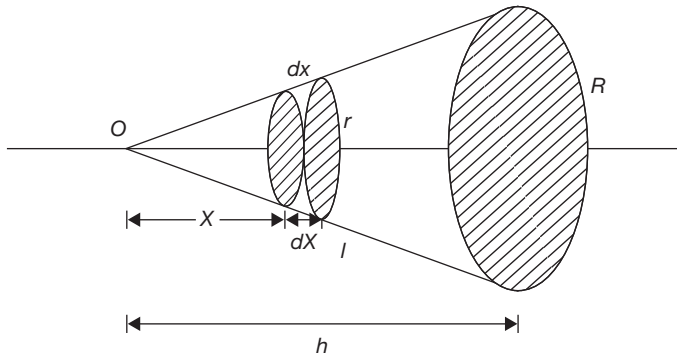
Moment of inertia of the plate element about axis

$$\begin{aligned} XX &= \frac{1}{2} \times \rho\pi x^2 dy \times y^2 = \frac{1}{2} \times \rho\pi x^4 dy \\ &= \frac{1}{2} \times \rho\pi (R^2 - y^2) y^2 dy = \frac{1}{2} \times \rho\pi (R^2 y^2 - y^4) dy \end{aligned}$$

$$\begin{aligned} I_{XX} \text{ of hemisphere} &= \int_0^R \frac{1}{2} \times \rho\pi (R^2 y^2 - y^4) dy = \rho\pi \left[ \frac{R^2 y^3}{3} - \frac{y^5}{5} \right]_0^R \\ &= \rho\pi R^5 \left[ \frac{1}{3} - \frac{1}{5} \right] = \frac{2}{15} \rho\pi R^5 = \frac{1}{10} MR^2 = I_{YY} \end{aligned}$$

### 11.5.5 Mass Moment of Inertia of a Circular Cone

Consider an elemental plate at a distance  $x$  from the apex of radius  $r$  and thickness  $dx$ . Mass of elemental plate =  $\rho\pi r^2 dx$

**FIGURE 11.24**

Mass Moment of Inertia of Circular Cone about its Axis of Rotation

The moment of inertia of circular plate about normal axis through its center is

$$= \frac{1}{2} \times \text{mass} \times \text{square of radius} = \frac{1}{2} \times \rho \pi r^2 dx \times r^2 = \rho \frac{\pi r^4 dx}{2}$$

But,  $r = \left(\frac{x}{h}\right)R$

Moment of inertia of the elemental plate about the axis  $= \rho \frac{\pi}{2} R^4 \frac{x^4}{h^4} dx$

Moment of inertia of cone about its axis,  $I_{XX} = \int_0^h \rho \frac{\pi}{2} R^4 \frac{x^4}{h^4} dx = \frac{\rho \pi R^4}{2 h^4} \left[ \frac{x^5}{5} \right]_0^h = \frac{\rho \pi R^4 h}{10}$

Mass of the cone,  $M = \frac{\rho \pi R^2 h}{3}$

Moment of inertia of cone about its axis,  $I_{XX} = \frac{3}{10} MR^2$



# RECAP ZONE .....



## Points to Remember

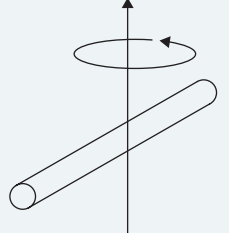
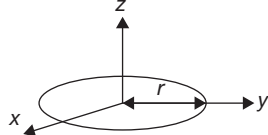
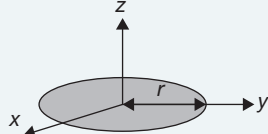
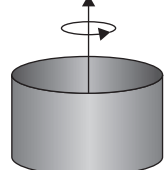
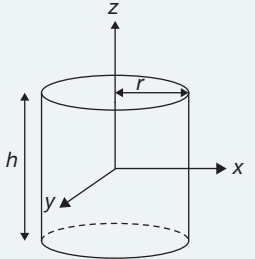
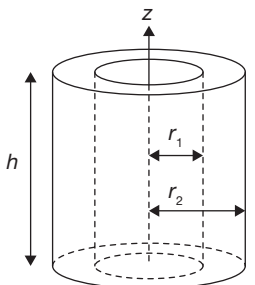
- The **centroid** is the mean position of elements of an area. The coordinates of the centroid are mean value of coordinates of all the elemental points in the area.
- The **center of mass** is the mean position of elements of mass. In a uniform gravitational field, the gravitational force acts through the center of mass. But, if the gravitational field (hypothetically) is not uniform (in the case of the very large body), the center of mass and center of gravity will be different.
- The centroid is a mathematical, geometric concept, i.e., the geometric center of a body. It can be calculated as the center of mass of an object with constant density throughout density.
- The **second moment of area** is also known as area moment of Inertia. Consider a small lamina of area  $A$ .
- The **second moment of area** about  $x$ -axis or  $y$ -axis can be found by integrating the second moment of area of small element of area  $dA$  of the lamina, i.e.,  $\int x^2 dA$  or  $\int y^2 dA$ .
- The product of the area and square of the distance of the centroid from an axis is known as area moment of Inertia.
- The **radius of gyration** of a body about an axis is a distance such that its square multiplied by the area gives a moment of inertia of the area about the given axis.
- **Theorem of perpendicular axis** states that if  $I_{XX}$  and  $I_{YY}$  be the moment of inertia of a plane section about two mutually perpendicular axes  $X-X$  and  $Y-Y$  in the plane of the section, then the moment of inertia of the section  $I_{ZZ}$  about the axis  $Z-Z$ , perpendicular to the plane and passing through the intersection of axes  $X-X$  and  $Y-Y$  is given by

$$I_{ZZ} = I_{XX} + I_{YY} = \int r^2 dA$$

- **Theorem of parallel axis** states that if the moment of inertia of a plane area about an axis in the plane of the area through centroid be represented by  $I_G$ , then the moment of inertia of the plane about a parallel axis  $AB$  ( $I_{AB}$ ) in the plane at a distance  $h$  from the centroid of the area is given by  $I_{AB} = I_G + Ah^2$ .
- **Mass moment of inertia** of a body about an axis is defined as the sum of the product of its elemental masses and square of their distances from the axis.

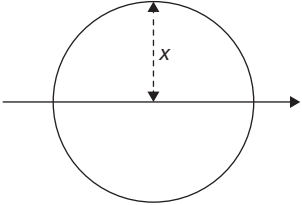
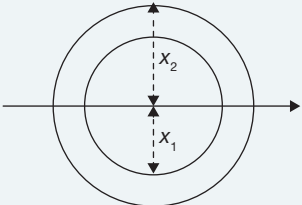
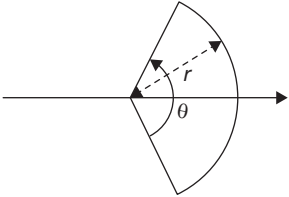
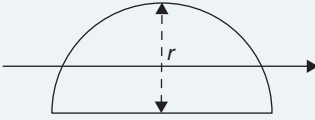
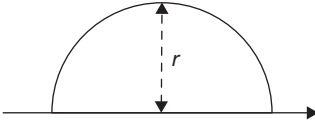
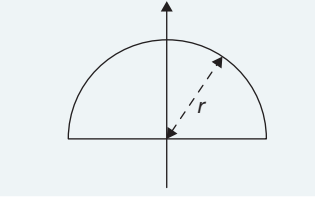
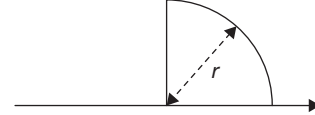
## List of Mass Moment of Inertia

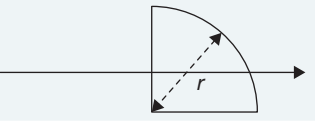
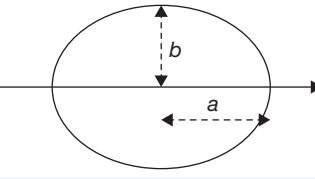
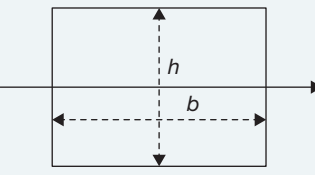
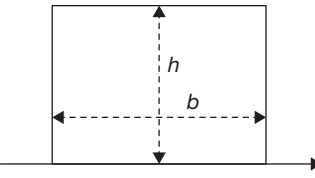
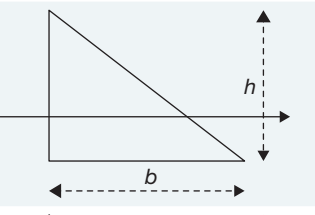
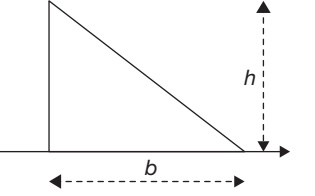
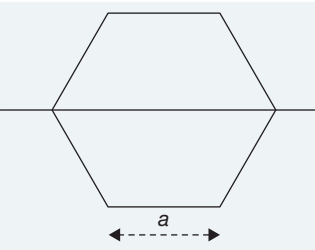
Description	Figure	Moment(s) of Inertia
Point mass $m$ at a distance $r$ from the axis of rotation.		$I = mr^2$
Two point masses, $M$ and $m$ , with reduced mass $\mu$ and separated by a distance, $x$ .		$I = \frac{Mm}{M+m} x^2 = \mu x^2$
Rod of length $L$ and mass $m$ (Axis of rotation at the end of the rod)		$I_{end} = \frac{mL^2}{3}$

Description	Figure	Moment(s) of Inertia
Rod of length $L$ and mass $m$		$I_{center} = \frac{mL^2}{12}$
Thin circular hoop of radius $r$ and mass $m$		$I_x = mr^2$ $I_x = I_y = \frac{mr^2}{2}$
Thin, solid disk of radius $r$ and mass $m$		$I_z = \frac{mr^2}{2}$ $I_x = I_y = \frac{mr^2}{4}$
Thin cylindrical shell with open ends, of radius $r$ and mass $m$		$I_x = mr^2$
Solid cylinder of radius $r$ , height $h$ and mass $m$		$I_z = \frac{mr^2}{2}$ $I_x = I_y = \frac{1}{12}m(3r^2 + h^2)$
Thick-walled cylindrical tube with open ends, of inner radius $r_1$ , outer radius $r_2$ , length $h$ and mass $m$		$I_z = \frac{1}{2}m(r_1^2 + r_2^2)$ $I_x = I_y = \frac{1}{12}m[3(r_2^2 + r_1^2) + h^2]$ <p>or when defining the normalized thickness <math>t_n = t/r</math> and letting <math>r = r_2</math>, then</p> $I_z = mr^2\left(1 - t_n + \frac{1}{2}t_n^2\right)$

Description	Figure	Moment(s) of Inertia
Tetrahedron of side $s$ and mass $m$		$I_{solid} = \frac{3ms^2}{7}$ $I_{hollow} = \frac{4ms^2}{7}$
Sphere (hollow) of radius $r$ and mass $m$		$I = \frac{2mr^2}{3}$
Ball (solid) of radius $r$ and mass $m$		$I = \frac{2mr^2}{5}$
Sphere (shell) of radius $r_2$ , with centered spherical cavity of radius $r_1$ and mass $m$		$I = \frac{2m}{5} \left[ \frac{r_2^5 - r_1^5}{r_2^3 - r_1^3} \right]$
Right circular cone with radius $r$ , height $h$ and mass $m$		$I_z = \frac{3}{10}mr^2$ $I_x = I_y = \frac{3}{5}m \left( \frac{r^2}{4} + h^2 \right)$

## List of Area Moment of Inertia

Description	Figure	Area Moment of Inertia
A filled circular area of radius $r$		$I_0 = \frac{\pi}{4} r^4$
An annulus of inner radius $r_1$ and outer radius $r_2$		$I_0 = \frac{\pi}{4} (r_2^4 - r_1^4)$
A filled circular sector of angle $\theta$ in radians and radius $r$ with respect to an axis through the centroid of the sector and the center of the circle		$I_0 = (\theta - \sin \theta) \frac{r^4}{8}$
A filled semicircle with radius $r$ with respect to a horizontal line passing through the centroid of the area		$I_0 = \left( \frac{\pi}{8} - \frac{8}{9\pi} \right) r^4 \approx 0.1098 r^4$
A filled semicircle as above but with respect to an axis collinear with the base		$I = \frac{\pi r^4}{8}$
A filled semicircle as above but with respect to a vertical axis through the centroid		$I_0 = \frac{\pi r^4}{8}$
A filled quarter circle with radius $r$ entirely in the 1st quadrant of the Cartesian coordinate system		$I_0 = \frac{\pi r^4}{16}$

Description	Figure	Area Moment of Inertia
A filled quarter circle as above but with respect to a horizontal or vertical axis through the centroid		$I_0 = \left( \frac{\pi}{16} - \frac{4}{9\pi} \right) r^4$
A filled ellipse whose radius along the x-axis is $a$ and whose radius along the y-axis is $b$		$I_0 = \frac{\pi}{4} ab^3$
A filled rectangular area with a base width of $b$ and height $h$		$I_0 = \frac{bh^3}{12}$
A filled rectangular area as above but with respect to an axis collinear with the base		$I = \frac{bh^3}{3}$
A filled triangular area with a base width of $b$ and height $h$ with respect to an axis through the centroid		$I_0 = \frac{bh^3}{36}$
A filled triangular area as above but with respect to an axis collinear with the base		$I = \frac{bh^3}{12}$
A filled regular hexagon with a side length of $a$		$I_0 = \frac{5\sqrt{3}}{16} a^4$

## Important Formulae

$$1. \quad W.\bar{X} = \sum W_i.X_i \text{ and } \bar{X} = \frac{\sum W_i.X_i}{W}$$

$$W.\bar{Y} = \sum W_i.Y_i \text{ and } \bar{Y} = \frac{\sum W_i.Y_i}{W}$$

$$W.\bar{Z} = \sum W_i.Z_i \text{ and } \bar{Z} = \frac{\sum W_i.Z_i}{W}$$

$$2. \quad M.\bar{X} = \sum M_i.X_i \text{ and } \bar{X} = \frac{\sum M_i.X_i}{M}$$

$$M.\bar{Y} = \sum M_i.Y_i \text{ and } \bar{Y} = \frac{\sum M_i.Y_i}{M}$$

$$M.\bar{Z} = \sum M_i.Z_i \text{ and } \bar{Z} = \frac{\sum M_i.Z_i}{M}$$

$$3. \quad A.\bar{X} = \sum A_i.X_i \text{ and } \bar{X} = \frac{\sum A_i.X_i}{A}$$

$$A.\bar{Y} = \sum A_i.Y_i \text{ and } \bar{Y} = \frac{\sum A_i.Y_i}{A}$$

$$A.\bar{Z} = \sum A_i.Z_i \text{ and } \bar{Z} = \frac{\sum A_i.Z_i}{A}$$

$$4. \quad \text{Centroid of circular arc } \bar{X} = \frac{R \sin \alpha}{\alpha}; \bar{Y} = 0$$

$$5. \quad \text{Centroid of semicircular-section of a disc } \bar{X} = 0; \bar{Y} = \frac{4R}{3\pi}$$

$$6. \quad \text{Centroid of a sector of a circular disc } \bar{X} = \frac{2R}{3\alpha} \sin \alpha; \bar{Y} = 0$$

$$7. \quad \text{Centroid of a parabola } \bar{X} = \frac{3a}{4}; \bar{Y} = \frac{3h}{10}$$

$$8. \quad \text{Centroid of a triangle } \bar{X} = \frac{b}{3}; \bar{Y} = \frac{h}{3}$$

$$9. \quad \text{Radius of gyration } k = \sqrt{\frac{I}{A}} = \sqrt{\frac{I}{M}}$$

$$10. \quad \text{Perpendicular axis theorem } I_{ZZ} = I_{XX} + I_{YY} = \int r^2 dA$$

$$11. \quad \text{Parallel axis theorem } I_{AB} = I_G + Ah^2$$



# REVIEW ZONE .....

## Multiple-choice Questions

- Which of the following forms the basis of rigid bodies and strength of material?
  - Centroid
  - Center of gravity
  - Moment of inertia
  - Any of the above
- “The moment of inertia of a lamina about any axis in the plane lamina equal the sum of the moment of inertia about a parallel centroidal axis in the plane lamina and the product of the area of the lamina and square of the distance between the two axes”.  
The above theorem is known as
  - Parallel axis theorem
  - Perpendicular axis theorem
  - Three-moment theorem
  - None of the above
- Centroid of a circular arc of radius  $R$  including angle  $2\alpha$  can be given by:
  - $\bar{X} = \frac{R \sin \alpha}{\alpha}; \bar{Y} = 0$
  - $\bar{X} = \frac{2R \sin \alpha}{\alpha}; \bar{Y} = 0$
  - $\bar{X} = \frac{R \sin 2\alpha}{\alpha}; \bar{Y} = 0$
  - $\bar{X} = \frac{R \sin 2\alpha}{2\alpha}; \bar{Y} = 0$
- Centroid of a semicircular disc of radius  $R$  can be given as:
  - $\bar{X} = 0; \bar{Y} = \frac{3R}{4\pi}$
  - $\bar{X} = 0; \bar{Y} = \frac{4R}{3\pi}$
  - $\bar{X} = \frac{4R}{3\pi}; \bar{Y} = \frac{4R}{3\pi}$
  - $\bar{X} = 0; \bar{Y} = \frac{2R}{3\pi}$
- Centroid of a sector of a circular disc of radius  $r$  and included angle  $2\alpha$  can be given as:
  - $\bar{X} = \frac{3R}{2\alpha} \sin \alpha; \bar{Y} = 0$
  - $\bar{X} = \frac{2R}{3\alpha} \sin 2\alpha; \bar{Y} = 0$
  - $\bar{X} = \frac{2R}{3\alpha} \sin \alpha; \bar{Y} = 0$
  - $\bar{X} = \frac{3R}{2\alpha} \sin 2\alpha; \bar{Y} = 0$
- Centroid of parabola of height  $h$  and base  $b$  ( $y = kx^2$ ) can be given as:
  - $\bar{X} = \frac{3h}{4}; \bar{Y} = \frac{3h}{10}$
  - $\bar{X} = \frac{3a}{4}; \bar{Y} = \frac{3a}{10}$
  - $\bar{X} = \frac{3h}{4}; \bar{Y} = \frac{3a}{10}$
  - $\bar{X} = \frac{3a}{4}; \bar{Y} = \frac{3h}{10}$
- Radius of gyration of a body can be given as:
  - $k = \sqrt{\frac{I}{A}}$
  - $k = \sqrt{\frac{I}{M}}$
  - $k = \sqrt{\frac{A}{I}}$
  - Both (a) and (b)
- Moment of inertia of a triangle of base  $b$  height  $h$  about its base can be given as:
  - $I_{AB} = \frac{b^3 h}{12}$
  - $I_{AB} = \frac{bh^3}{12}$
  - $I_{AB} = \frac{bh^3}{36}$
  - None of these
- Moment of inertia of a triangle of base  $b$  height  $h$  about its center parallel to its base can be given as:
  - $I_G = \frac{b^3 h}{12}$
  - $I_G = \frac{bh^3}{12}$
  - $I_G = \frac{bh^3}{36}$
  - None of these
- Moment of inertia of a circular disc about its diametral axis can be given as:
  - $\frac{\pi r^4}{64}$
  - $\frac{\pi d^4}{32}$

- (c)  $\frac{\pi r^4}{32}$                       (d)  $\frac{\pi d^4}{64}$
11. Polar moment of inertia of a circular disc about its diametral axis can be given as:
- (a)  $\frac{\pi r^4}{64}$                       (b)  $\frac{\pi d^4}{32}$
- (c)  $\frac{\pi r^4}{32}$                       (d)  $\frac{\pi d^4}{64}$
12. Mass moment of inertia of a sphere of radius R can be given as:
- (a)  $\frac{2}{5}MR^2$                       (b)  $\frac{2}{5}MD^2$
- (c)  $\frac{3}{5}MR^2$                       (d)  $\frac{3}{5}MD^2$
13. Mass moment of inertia of a circular cone of radius R and height h about its axis of rotation can be given as:
- (a)  $\frac{3}{10}MR^2$                       (b)  $\frac{7}{10}MR^2$
- (c)  $\frac{3}{10}Mh^2$                       (d)  $\frac{7}{10}Mh^2$
14. Mass moment of inertia of a hemisphere of radius R about axis perpendicular to its diametral plane can be given as:
- (a)  $\frac{2}{5}MR^2$                       (b)  $\frac{2}{5}MD^2$
- (c)  $\frac{1}{5}MR^2$                       (d)  $\frac{3}{5}MD^2$
15. Mass moment of inertia of a hemisphere of radius R about an axis passing through its center in its diametral plane can be given as:
- (a)  $\frac{1}{10}MR^2$                       (b)  $\frac{2}{5}MD^2$
- (c)  $\frac{2}{5}MR^2$                       (d)  $\frac{3}{5}MD^2$

## Answers

- |         |         |         |         |         |         |
|---------|---------|---------|---------|---------|---------|
| 1. (c)  | 2. (a)  | 3. (a)  | 4. (b)  | 5. (c)  | 6. (d)  |
| 7. (d)  | 8. (b)  | 9. (c)  | 10. (d) | 11. (b) | 12. (a) |
| 13. (a) | 14. (c) | 15. (a) |         |         |         |

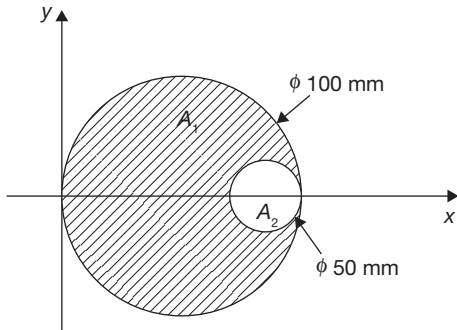
## Theory Questions

- What do you mean by centroid and center of gravity? What is the basic difference between centroid and center of gravity?
- Find the centroid of a rod of length L, and mass M, using the first principle.
- State the perpendicular and parallel axis theorem.
- Find the expression for the center of gravity for the hemisphere.
- Find the mass moment of inertia of hemisphere about a diametral axis.
- Find the moment of inertia of a triangle about the line parallel to its base and passing through the centroid.
- Find the moment of inertia of a disc:
  - About a line perpendicular to the plane of the disc and passing through the centroid.
  - About a line parallel to the plane of the disc and passing through the centroid.
  - About a line perpendicular to the plane of the disc and passing through the perimeter.
  - About a line of a tangent.
- Find the expression for mass moment of inertia of a sphere.
- Find the mass moment of inertia of a hollow cylinder about its axis passing through the centroid.
- Differentiate area moment of inertia from the mass moment of inertia.



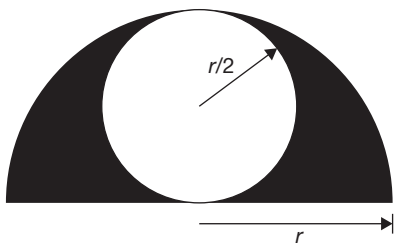
### Numerical Problems

- From a circular plate of diameter 100 mm, a circular part is cut out whose diameter is 50 mm as shown in Figure 11.25. Find the centroid of the remaining part.



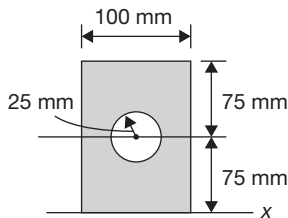
**FIGURE 11.25**

- From a semi-circular lamina of radius  $r$ , a circular lamina of radius  $r/2$  is removed as shown in Figure 11.26. Find the position of the centroid of the remaining part.



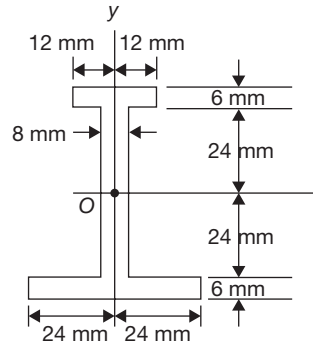
**FIGURE 11.26**

- Compute the moment of inertia of the composite area as shown in Figure 11.27 about the axis  $xx$ .



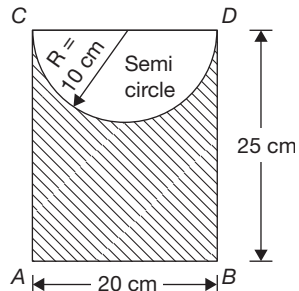
**FIGURE 11.27**

- Determine the moments of inertia and the radius of gyration of the section as shown in Figure 11.28 with respect to the  $x$  and  $y$ -axes.



**FIGURE 11.28**

- Find the moment of inertia of the shaded section about the edge  $AB$  as shown in Figure 11.29.



**FIGURE 11.29**

## Learning Objectives

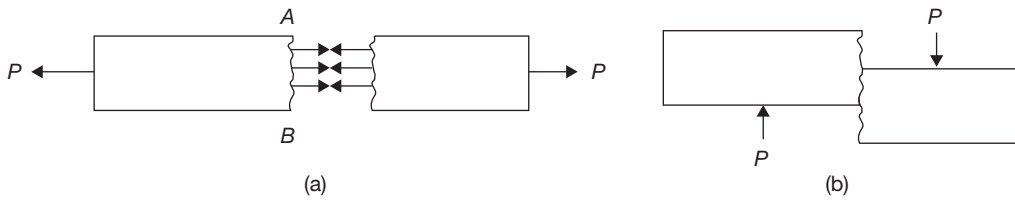
*By the end of this chapter, the student will be able:*

- To demonstrate the Hook's law
- To describe the behaviour of the engineering materials under different types of loadings
- To calculate the stress and strain produced in a material under different types of loading
- To understand the concepts of principal stress and strain
- To demonstrate the Mohr's circle for principal stress and principal strain

### 12.1 ► INTRODUCTION

There are certain behaviors of all materials under the influence of an external force. Stress and strain are one of the measures to show these behaviors. Stress is a resistive force per unit area, which is developed internally to oppose the external force subjected to the material. The strain is a measure of deformation of the material per unit dimensions. If the stress developed in the material is perpendicular to the cross-section, it is known as direct stress and if it is tangential or parallel to the cross-section, it is known as shear stress.

In Figure 12.1 (a), a cylindrical job is subjected by a load  $P$ . If the specimen is broken at  $AB$ , the same amount of stress will be developed for equilibrium at the section  $AB$  which is known as direct stress. Direct stress can be explained as average stress and normal stress. Since stress is force developed per unit area. It is not necessary that amount of force on every



**FIGURE 12.1**

(a) Cylindrical Job Subjected to Axial Load and (b) Cylindrical Job Subjected to External Load Parallel to Cross-section

point on cross-section AB will be same. It depends on direction and point of application of external force P, so it is known as average stress ( $\sigma$ ).

$$\sigma = \frac{dP}{dA}$$

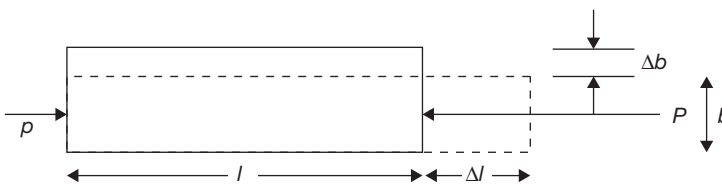
If the stress distribution along the cross-section is uniform, it is known as simple or normal stress.  $\sigma = P/A$ . To develop normal stress, the external force P must be passed through the centroidal axis.

In Figure 12.1 (b), an external load P is subjected to the specimen parallel to the cross section. There will be resistance just opposite to the external load which is parallel to the cross section and known as shear force. Again shear stress distribution may or may not be uniform along the cross-section.

Strain is a way to show the deformation in the material. In Figure 12.2, the deformations are shown in two directions: one in the direction of load application and other in the direction perpendicular to load application. The strain produced in the direction of load is known as longitudinal strain and the strain produced perpendicular to load application is known as lateral strain.

The ratio of lateral to longitudinal strain is constant which is known as Poisson's ratio ( $\nu$ ).

$$\nu = -\frac{\text{Lateral strain}}{\text{Longitudinal strain}} = -\frac{\epsilon_y}{\epsilon_x} = -\frac{\epsilon_z}{\epsilon_x}$$



**FIGURE 12.2**

Longitudinal and Lateral Strain

The value of  $\nu$  for steel ranges from 0.25 and 0.33.

Volumetric strain,  $\epsilon_v = \frac{\delta V}{V}$ ; Superficial strain,  $\epsilon_s = \frac{\delta A}{A}$ ; where  $\Delta V$  is the change in volume,  $V$  is original volume,  $\Delta A$  is a change in the area, and  $A$  is the original area.

## 12.2 ► HOOKE'S LAW

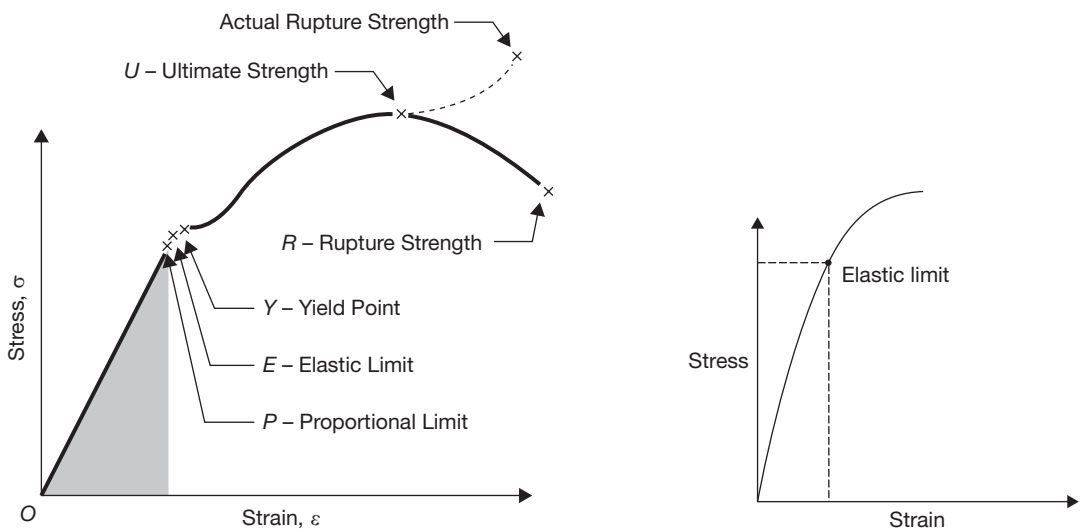
Hook's law states that stress and strain are perpendicular to each other under the elastic limit. Originally, Hooke's law specified that stress was proportional to strain but Thomas Young introduced a constant of proportionality which is known as Young's modulus. Further, this name was superseded by modulus of elasticity.

$$E = \frac{\sigma}{\epsilon}$$

Where  $E$  is the modulus of elasticity;  $\sigma$  is stress, and  $\epsilon$  is a strain.

## 12.3 ► STRESS–STRAIN DIAGRAM

Hooke's law states that stress and strain are proportional to each other under the elastic limit. Originally, Hooke's law specified that stress was proportional to strain but later Thomas Young introduced a constant of proportionality which is known as Young's modulus of elasticity. Further, this name was superseded by the modulus of elasticity. Figure 12.3 demonstrates the Hooke's Law.



(a) Stress-strain diagram for ductile material

(b) Stress-strain diagram for brittle material

### FIGURE 12.3

Hook's Law

**Working Stress, Allowable Stress, and Factor of Safety:** Working stress is defined as the actual stress of a material under a given loading. The maximum safe stress that a material can carry is termed as the allowable stress. The allowable stress should be limited to values not exceeding the proportional limit. However, since the proportional limit is difficult to determine accurately, the allowable stress is taken as either the yield point or ultimate strength divided by a factor of safety. The ratio of this strength (ultimate or yield strength) to allowable strength is called the factor of safety.

The relationship between gauge length and cross-sectional area of the tensile test specimen can be given as  $L_{gauge} = 5.65\sqrt{A}$ , where A is an area of cross-section.

Note: Stress-strain diagram for medium carbon steel refer Ch.17.

### EXAMPLE 12.1

A mild steel specimen with an original diameter of 10 mm and a gauge length of 50 mm was found to have an ultimate load of 60 kN and breaking load of 40 kN. The gauge length at rupture was 55 mm and diameter at rupture cross-section was 8 mm. Determine: (i) the ultimate stress, (ii) Breaking stress, (iii) True breaking stress, (iv) percentage elongation, and (v) percentage reduction in area.

### SOLUTION

Given:  $l_g = 50$  mm,  $d_o = 10$  mm,  $l_f = 55$  mm,  $P_{ult} = 60$  kN,  $P_{break} = 40$  kN, and  $d_f = 8$  mm.

$$A_o = \frac{\pi d_o^2}{4} = \frac{\pi \times (10 \text{ mm})^2}{4} = 78.53 \text{ mm}^2$$

$$A_f = \frac{\pi d_f^2}{4} = \frac{\pi \times (8 \text{ mm})^2}{4} = 50.26 \text{ mm}^2$$

(a) Ultimate stress,  $\sigma_{ult} = \frac{P_{ult}}{A_o} = \frac{60 \times 10^3 \text{ N}}{78.53 \text{ mm}^2} = 764.039 \text{ N/mm}^2$

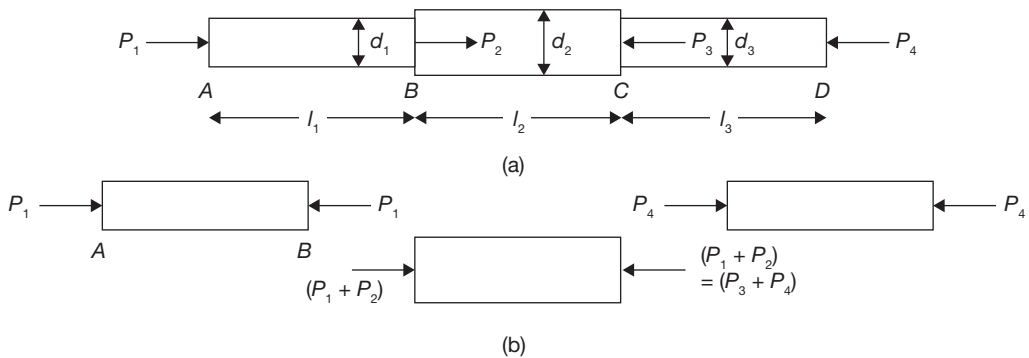
(b) Breaking stress,  $\sigma_{brak} = \frac{P_{break}}{A_o} = \frac{40 \times 10^3 \text{ N}}{78.53 \text{ mm}^2} = 509.359 \text{ N/mm}^2$

(c) True breaking stress,  $\sigma_{Tru_{break}} = \frac{P_{break}}{A_f} = \frac{40 \times 10^3 \text{ N}}{50.26 \text{ mm}^2} = 795.861 \text{ N/mm}^2$

(d) Percentage elongation  $= \frac{l_f - l_o}{l_o} \times 100 = \frac{55 \text{ mm} - 50 \text{ mm}}{50 \text{ mm}} \times 100 = 10\%$

(e) Percentage reduction in area  $= \frac{A_o - A_f}{A_o} \times 100 = \frac{78.53 \text{ mm}^2 - 50.26 \text{ mm}^2}{78.53 \text{ mm}^2} \times 100 = 35.9\%$

### Stress and Strain in Simple Stepped Bar



**FIGURE 12.4**

Stress–Strain in Stepped Bar

Let us consider a stepped bar of diameters  $d_1$ ,  $d_2$ , and  $d_3$  as shown in Figure 12.4 (a). Different forces of the magnitude of  $P_1$ ,  $P_2$ ,  $P_3$ , and  $P_4$  are acting at a different section of the bar. Free body diagram of these sections are shown in Figure 12.4 (b).

$$\text{For section AB: } \sigma_{AB} = \frac{P_1}{A_1} = \frac{P_1}{\frac{\pi d_1^2}{4}}; \delta_{AB} = \epsilon_{AB} \times l_1 = \frac{\sigma_{AB} \times l_1}{E_1} = \frac{4P_1 \times l_1}{\pi d_1^2 E_1}$$

$$\text{For section BC: } \sigma_{BC} = \frac{P_1 + P_2}{A_2} = \frac{P_1 + P_2}{\frac{\pi d_2^2}{4}}; \delta_{BC} = \epsilon_{BC} \times l_2 = \frac{\sigma_{BC} \times l_2}{E_1} = \frac{4(P_1 + P_2) \times l_2}{\pi d_2^2 E_2}$$

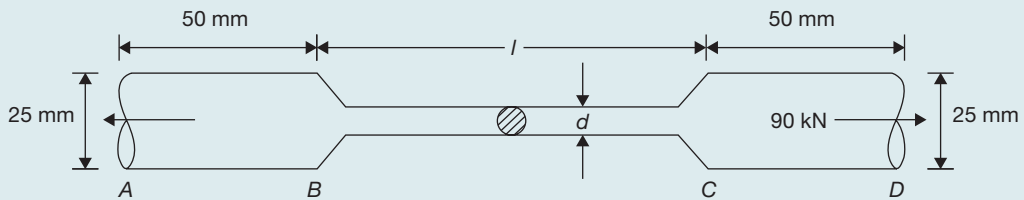
$$\text{For section CD: } \sigma_{CD} = \frac{P_4}{A_3} = \frac{P_4}{\frac{\pi d_3^2}{4}}; \delta_{CD} = \epsilon_{CD} \times l_3 = \frac{\sigma_{CD} \times l_3}{E_3} = \frac{4P_4 \times l_3}{\pi d_3^2 E_3} \text{ and } \delta = \delta_{AB} + \delta_{BC} + \delta_{CD}$$

Here  $\delta$  is total deflection in the bar.

#### EXAMPLE 12.2

There is a specimen for a tensile test of a material. It has a circular cross-section and enlarged ends as shown in Figure 12.5.

The total elongation is 10 mm. The lengths of the enlarged ends are equal to 50 mm and diameter 25 mm for each end. The length and diameter of the middle portion are to be found. The tensile loads applied at the ends are 90 kN and stress produced in the middle portion is 450 MN/m<sup>2</sup>. Find the length  $l$  and diameter  $d$  for the middle portion of the specimen.  $E = 2 \times 10^5$  MPa.



**FIGURE 12.5**

Specimen for Tensile Test

**SOLUTION**

Cross-section area of the middle portion =  $\frac{\pi}{4}d^2$

$$\sigma = \frac{P}{A}$$

Stress produced in the middle portion =  $450 \times 10^6 \text{ N/m}^2 = \frac{90 \times 10^3 \text{ N}}{\pi d^2/4}$

or,

$$d = \sqrt{\frac{4 \times 90 \times 10^3 \text{ N}}{\pi \times 450 \times 10^6 \text{ N/m}^2}} = 15 \text{ mm.}$$

Elongation produced in the end portions of the specimen

$$\delta l_{AB+CD} = 2 \times \left\{ \frac{\sigma_{AB} \times l_{AB}}{E} \right\} = 2 \times \left\{ \frac{4 \times (90 \times 10^3 \text{ N}) \times 0.05 \text{ m}}{\pi \times (.025 \text{ m})^2 \times (2 \times 10^5 \times 10^6) \text{ N/m}^2} \right\} = 0.0917 \text{ mm}$$

$$\delta l_{BC} = \frac{450 \times 10^6 \text{ N/m}^2}{2 \times 10^5 \times 10^6 \text{ N/m}^2} \times l_{BC} = 2.25 \times l_{BC} \text{ mm}$$

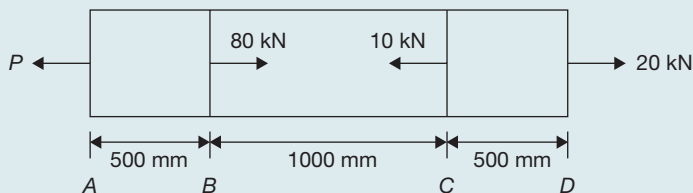
Total elongation,  $\delta l = 10 \text{ mm} = \delta l_{AB} + \delta l_{CD} + \delta l_{BC} = 0.0917 \text{ mm} + 2.25 \times l_{BC}$

or

$$l_{BC} = 4.40 \text{ mm}$$

**EXAMPLE 12.3**

A brass rod in static equilibrium is subjected to axial load as shown in Figure 12.6:



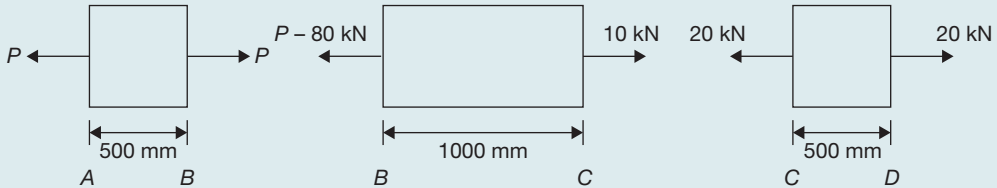
**FIGURE 12.6**

A Bar Under Static Equilibrium

Find the load  $P$  and change in length of the rod if its diameter is 100 mm. Take  $E = 80 \text{ GN/m}^2$ .

### SOLUTION

Draw the free body diagram for each part of the rod as shown below:



**FIGURE 12.7**

Free Body Diagram

$$P - 80 \text{ kN} = 10 \text{ kN} \Rightarrow P = 90 \text{ kN}.$$

$$\text{Change in length, } \delta l = \frac{1}{EA} [P_{AB} \times l_{AB} + P_{BC} \times l_{BC} + P_{CD} \times l_{CD}]$$

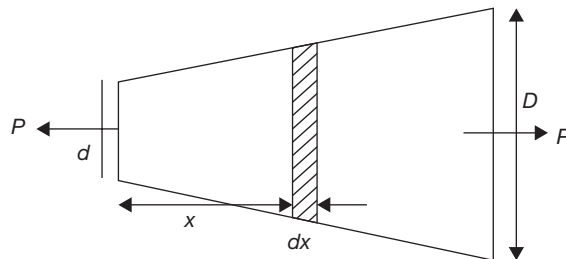
$$= \frac{4}{80 \times 10^9 \text{ N/m}^2 \times \pi \times (0.1 \text{ m})^2}$$

$$[90 \times 10^3 \text{ N} \times 0.5 \text{ m} + 10 \times 10^3 \text{ N} \times 1.0 \text{ m} + 20 \times 10^3 \text{ N} \times 0.5 \text{ m}]$$

$$= 9.549 \times 10^{-3} \text{ m}.$$

## 12.4 ► EXTENSION IN VARYING CROSS-SECTION OR TAPER ROD

A rod of length  $l$  tapers uniformly from a diameter  $D$  at one end to diameter  $d$  at another end as shown in Figure 12.8. Considering a small element of thickness  $dx$  at distance  $x$  from the end of diameter  $d$ , the diameter of the element is calculated as  $d + (D - d)\frac{x}{l}$ .



**FIGURE 12.8**

Extension in Taper Rod



$$\text{Extension in the element of length } dx = \frac{4Pdx}{\pi \left[ d + (D-d)\frac{x}{l} \right]^2 E}$$

$$\begin{aligned} \text{Total extension in the bar, } \delta l &= \int_0^l \frac{4Pdx}{\pi \left[ d + (D-d)\frac{x}{l} \right]^2 E} = -\frac{1}{D-d} \times \frac{4P}{\pi E} \left[ \frac{1}{d + (D-d)\frac{x}{l}} \right]_0^l \\ &= \frac{4Pl}{\pi E(D-d)} \left( \frac{1}{d} - \frac{1}{D} \right) = \frac{4Pl}{\pi DdE} \end{aligned}$$

**EXAMPLE 12.4**

A rod tapers uniformly from 50 mm to 20 mm diameter in a length of 500 mm. If the rod is subjected to an axial load of 10 kN, find the extension in the rod. Assume  $E = 2 \times 10^5$  MPa.

**SOLUTION**

$D = 0.05$  m,  $d = 0.02$  m,  $l = 0.5$  m,  $P = 10 \times 10^3$  N, and  $E = 2 \times 10^{11}$  N/m<sup>2</sup>.

$$\delta l = \frac{4Pl}{\pi DdE} = \frac{4 \times 10 \times 10^3 \text{ N} \times 0.5 \text{ m}}{\pi \times 0.05 \text{ m} \times 0.02 \text{ m} \times 2 \times 10^{11} \text{ N/m}^2} = 3.1830 \times 10^{-5} \text{ m} = \mathbf{0.0318 \text{ mm}}$$

**EXAMPLE 12.5**

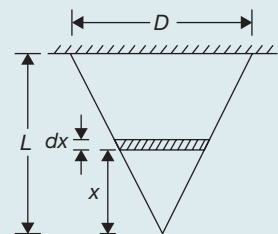
Determine the elongation of a conical bar under the action of its own weight, if the length of the bar is  $L$ , the diameter of the base is  $D$  and the weight per unit volume of the material is  $\rho$ .

**SOLUTION**

Consider a section of small length  $dx$  at a height  $x$  from the apex cone (as shown in Figure 12.9) where the diameter is  $\frac{D}{L} \times x$ , and weight of the cone below the section  $W = \frac{1}{3} \rho Ax$

$$\text{Elongation in the section} = \frac{\sigma}{E} = \frac{\frac{1}{3} \rho Ax}{AE} dx = \frac{\rho x dx}{3E}$$

$$\text{Total elongation of the bar, } \delta l = \int_0^L \frac{\rho x dx}{3E} = \frac{\rho L^2}{6E}$$

**FIGURE 12.9**

Conical Bar

## 12.5 ► STRESS AND STRAIN IN VARYING CROSS-SECTION BAR OF UNIFORM STRENGTH

Consider a bar of varying cross-section of uniform strength subjected by a longitudinal stress  $\sigma$  as shown in Figure 12.10. Now consider a small element of axial length  $\delta x$  at a distance of  $x$  from smaller end. Let, the area of the cross-section at section  $x$  be  $A$  and at section  $x + \delta x$  be  $A + \delta A$ . For the element of length  $\delta x$  to be in equilibrium, the total downward force must be equal to the total upward force acting on it.

Weight of length  $\delta x$  + tensile stress at section  $x \times$  area at section  $x$   
 = Tensile stress at section  $(x + \delta x) \times$  area at section  $(x + \delta x)$

$$\delta W + \sigma \times A = \sigma \times (A + \delta A)$$

Here,  $\delta W$  is vertical weight due to weight of free body =  $\rho \times g \times A \times \delta x$  where  $\rho$  is the density of material of the bar.

$$\rho \times g \times A \times \delta x + \sigma \times A = \sigma \times A + \sigma \times \delta A$$

Thus, 
$$\frac{\delta A}{\delta x} = \frac{\rho \times g \times A}{\sigma}$$

or, 
$$\frac{dA}{dx} = \frac{\rho \times g \times A}{\sigma} \Rightarrow \frac{dA}{A} = g \cdot \frac{\rho}{\sigma} \cdot dx$$

On integration, between area  $A_1$  and  $A$

$$\int_{A_1}^A \frac{dA}{A} = \int_0^x \frac{\rho g}{\sigma} \cdot dx \quad \text{or,} \quad \log_e \left[ \frac{A}{A_1} \right] = \frac{\rho g}{\sigma} \cdot x$$

Hence, 
$$A = A_1 \exp \left( \frac{\rho g x}{\sigma} \right)$$

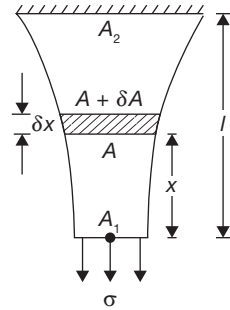
$$A_2 = A_1 \exp \left( \frac{g \rho l}{\sigma} \right)$$

or, 
$$\frac{A}{A_2} = e^{-\frac{g \rho (l-x)}{\sigma}} \quad \text{or,} \quad A = A_2 e^{-\frac{g \rho (l-x)}{\sigma}}$$

Let  $de$  be the extension in a small length  $dx$ .

$$\frac{de}{dx} = \text{strain} = \frac{\sigma}{E} dx$$

$$e = \int_0^l \frac{\sigma}{E} dx = \frac{\sigma l}{E}$$



**FIGURE 12.10**

Varying Cross-section Bar of Uniform Strength

**EXAMPLE 12.6**

A bar of uniform strength is shown in Figure 12.11: Its length is 5 m, diameter at bottom edge is 100 mm, weight density of bar is  $0.07644 \times 10^{-3} \text{ N/mm}^2$ . It is subjected to a uniform stress  $0.6 \text{ N/mm}^2$ . Find the diameters at the top and at the half of its length.

**SOLUTION**

Given  $d = 100 \text{ mm}$ ,  $l_1 = 5 \text{ m}$ ,  $\sigma = 0.6 \text{ N/mm}^2$ ,  
 $\rho = 0.07644 \times 10^{-3} \text{ N/mm}^2$ .

$$A_2 = A_1 \exp\left(\frac{g\rho l}{\sigma}\right) = \frac{\pi}{4} d_1^2 \times e^{\frac{g\rho l}{\sigma}}$$

$$= \frac{\pi}{4} (100 \text{ mm})^2 \times e^{\frac{0.07644 \times 10^{-3} \text{ N/mm}^2 \times 5000 \text{ mm}}{0.6 \text{ N/mm}^2}}$$

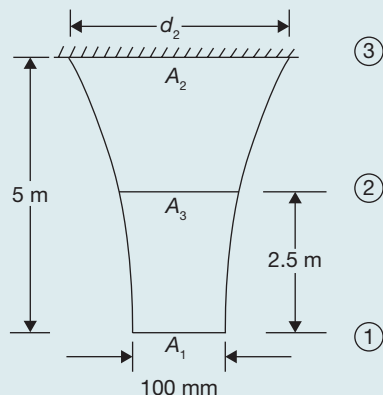
$$= 14845.359 \text{ mm}^2$$

$$d_2 = \sqrt{\frac{4A_2}{\pi}} = \sqrt{\frac{4 \times 14845.359 \text{ mm}^2}{\pi}} = 137.4834 \text{ mm}$$

$$A_3 = A_1 \exp\left(\frac{g\rho l/2}{\sigma}\right) = \frac{\pi}{4} d_1^2 \times e^{\frac{g\rho l/2}{\sigma}}$$

$$= \frac{\pi}{4} (100 \text{ mm})^2 \times e^{\frac{0.07644 \times 10^{-3} \text{ N/mm}^2 \times 2500 \text{ mm}}{0.6 \text{ N/mm}^2}} = 10799.724 \text{ mm}^2$$

$$d_3 = \sqrt{\frac{4A_3}{\pi}} = \sqrt{\frac{4 \times 10799.724 \text{ mm}^2}{\pi}} = 117.263 \text{ mm}$$

**FIGURE 12.11**

Bar of Uniform Strength

**12.6 ► STRESS AND STRAIN IN COMPOUND BAR**

Any tensile or compressive member which consists of two or more bars or tubes in parallel, usually of different materials, is called a compound bar. Figure 12.12 shows an example of the compound bar; it consists of a tube and a rod of different materials.

Since the initial length of tube and rod are same and it will remain together after application of external force  $P$ . Therefore, the strain in each part must be same. Suppose the loads shared by tube and rod is  $P_1$  and  $P_2$  out of total load  $P$ .

$$\epsilon_1 = \epsilon_2$$

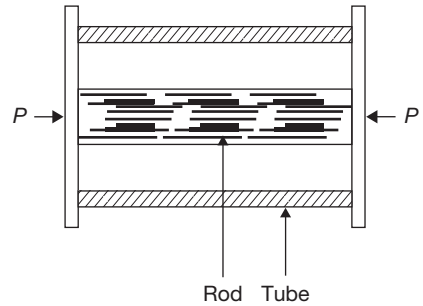
$$\frac{P_1}{A_1 E_1} = \frac{P_2}{A_2 E_2} \quad (12.1)$$

where  $A_1$  and  $A_2$  are cross-section of tube and rod, respectively;  $E_1$  and  $E_2$  are modulus of elasticity of tube and rod materials, respectively.

$$P_1 + P_2 = P \quad (12.2)$$

On solving Equations (12.1) and (12.2), we get

$$P_1 = \frac{A_1 E_1}{A_1 E_1 + A_2 E_2} \times P \quad \text{and} \quad P_2 = \frac{A_2 E_2}{A_1 E_1 + A_2 E_2} \times P$$



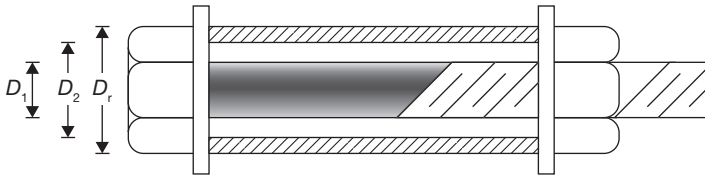
**FIGURE 12.12**  
Compound Bar

## 12.7 ► STRESS AND STRAIN IN AN ASSEMBLY OF TUBE AND BOLT

Figure 12.13 shows stress and strain produced in a compound rod.

Pull on rod = Push on tube

$$\sigma_t \left( \frac{\pi}{4} \right) D_r^2 = \sigma_c \left( \frac{\pi}{4} \right) (D_1^2 - D_2^2)$$



**FIGURE 12.13**

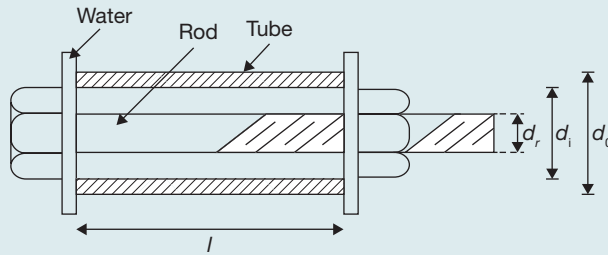
An Assembly of Tube and Bolt

where  $r$  subscript is used for rod. Rod is subjected to tensile stress and tube is subjected to compressive stress.

The reduction in length of tube and extension in rod may be different due to difference in materials of tube and rod.

### EXAMPLE 12.7

A steel rod of 20 mm diameter passes centrally through a steel tube of internal and external diameters of 25 mm and 30 mm, respectively. The tube is 800 mm long and is closed by rigid washers of negligible thickness which is fastened by nuts threaded on the rod. The assembly diagram is shown in Figure 12.14.



**FIGURE 12.14**

Compound Bar as an Assembly of Tube and Rod

- (a) The nuts are tightened until the compressive load on the tube reaches 25 kN, calculate the stress on the tube and the rod.
- (b) Find the increase in these stresses when one nut is tightened by one-quarter of a turn relative to the other. There are 5 threads per 10 mm. Take  $E = 200 \text{ kN/mm}^2$ .

### SOLUTION

When the nut is tightened, there will be a compressive load on the tube which will be equal to the tensile load on the rod. Compressive stress cannot be equal to tensile stress because it depends on cross section area and strength of the material.

$P_r = P_t = P$ , where  $P_r$  and  $P_t$  are loads on rod and tube, respectively.

$\sigma_r A_r = \sigma_t A_t$ , where  $\sigma_r$  and  $\sigma_t$  are tensile stress on rod and compressive stress on tube, respectively; and  $A_r$  and  $A_t$  are the cross-sectional areas of the rod and tube, respectively.

$$\sigma_r = \frac{A_t}{A_r} \sigma_t = \frac{\frac{\pi}{4}(d_o^2 - d_i^2)}{\frac{\pi}{4}d_r^2} \sigma_t = \frac{((30\text{mm})^2 - (25\text{mm})^2)}{(20\text{mm})^2} \times \sigma_t = 0.6875 \sigma_t$$

(a) Compressive stress on tube,  $\sigma_t = \frac{P}{A_t} = \frac{25 \times 10^3 \text{ N}}{\frac{\pi}{4}((30\text{mm})^2 - (25\text{mm})^2)} = 115.74 \text{ N/mm}^2$ .

Tensile stress on rod,  $\sigma_r = 0.6875 \sigma_t = 0.6875 \times 115.74 \text{ N/mm}^2 = 79.57 \text{ N/mm}^2$

(b) Let  $\sigma_r^1$  and  $\sigma_t^1$  be the stress due to tightening of nut by one quarter of a turn.

$$\sigma_r^1 = 0.6875 \sigma_t^1$$

Reduction in the length of the tube  $= \frac{\sigma_t^1}{E} \times l = \frac{\sigma_t^1}{200 \times 10^3 \text{ N/mm}^2} \times 800 \text{ mm} = 0.004 \sigma_t^1 \text{ mm}$

$$\text{Extension in the rod} = \frac{\sigma_r^1}{E} \times l = \frac{0.6875\sigma_t^1}{200 \times 10^3 \text{ N/mm}^2} \times 800 \text{ mm} = 0.00275\sigma_t^1 \text{ mm}$$

But, contraction in the tube + Extension in the rod = Axial movement of the nut

$$0.004\sigma_t^1 + 0.00275\sigma_t^1 = \frac{1}{4} \times \frac{10 \text{ mm}}{5 \text{ threads}}$$

$$\sigma_t^1 = 74 \text{ N/mm}^2 \text{ and } \sigma_r^1 = 0.6875 \sigma_t^1 = 50.92 \text{ N/mm}^2$$

### EXAMPLE 12.8

In example 12.7, the nut is removed and tube and rod are welded to washers and a compressive load of 25 kN is applied on washers as shown in the given Figure:

Find the stresses in tube and rod.



**FIGURE 12.15**

Fixed End of Tube and Rod Assembly

### SOLUTION

In this case change in length in tube and rod will be same as shown in Figure 12.15.

i.e.,

$$\delta l_t = \delta l_r$$

$$\text{or, } \frac{P_t}{A_t E_t} \times l = \frac{P_r}{A_r E_r} \times l$$

$$\text{or, } \frac{P_t}{A_t} = \frac{P_r}{A_r}; \text{ since } E_t = E_r = E \text{ (for same material).}$$

$$\text{or, } P_t = \frac{A_t}{A_r} \times P_r \quad (12.3)$$

$$\text{and also } P = P_t + P_r \quad (12.4)$$

On solving Equations (12.3) and (12.4), we get

$$P = \frac{A_t}{A_r} \times P + P_r = P_r \left( \frac{A_t}{A_r} + 1 \right)$$

$$\text{or, } P_r = \frac{P}{\left( \frac{A_t}{A_r} + 1 \right)} = \frac{25 \times 10^3 \text{ N}}{(0.6875 + 1)} = 14.81 \text{ kN}$$

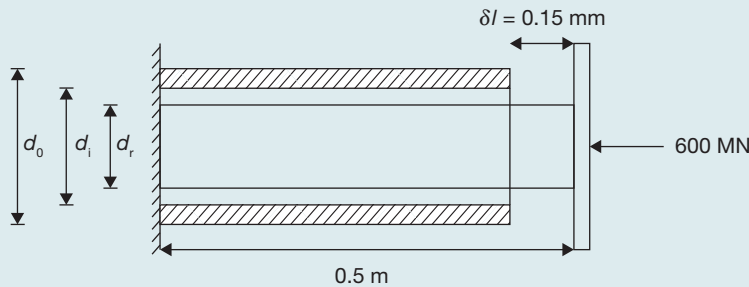
$$P_t = P - P_r = 25 \text{ kN} - 14.81 \text{ kN} = 10.18 \text{ kN}$$

$$\text{Stress in tube, } \sigma_t = \frac{P_t}{A_t} = \frac{10.18 \times 10^3 \text{ N}}{\frac{\pi}{4}(d_o^2 - d_i^2)} = \frac{10.18 \times 10^3 \text{ N}}{\frac{\pi}{4}((30\text{mm})^2 - (25\text{mm})^2)} = 47.133 \text{ N/mm}^2$$

$$\text{Stress in rod, } \sigma_r = \frac{P_r}{A_r} = \frac{14.81 \times 10^3 \text{ N}}{\frac{\pi}{4}(d_r^2)} = \frac{14.81 \times 10^3 \text{ N}}{\frac{\pi}{4}((20\text{mm})^2)} = 47.165 \text{ N/mm}^2$$

### EXAMPLE 12.9

A solid steel bar 0.5 m long and 0.07 m in diameter, is placed inside an aluminum tube having 0.075 m inside diameter and 0.10 m outside diameter. The steel bar is 0.15 mm longer than the aluminum tube. An axial load of 600 MN is applied to the bar and cylinder through rigid cover plate as shown in Figure 12.16:



**FIGURE 12.16**

Steel Bar and Aluminum Tube Assembly

Find the stress developed in steel bar and cylinder through the rigid cover plate.

### SOLUTION

$$\begin{aligned} \text{Cross-sectional area of tube, } A_{Al} &= \frac{\pi}{4}(d_o^2 - d_i^2) = \frac{\pi}{4}((0.10\text{m})^2 - (0.075\text{m})^2) \\ &= 3.436 \times 10^{-3} \text{ m}^2 \end{aligned}$$

$$\begin{aligned} \text{Cross-sectional area of steel rod, } A_{steel} &= \frac{\pi}{4}(d_r^2) = \frac{\pi}{4}(0.07\text{m})^2 \\ &= 3.84 \times 10^{-3} \text{ m}^2 \end{aligned}$$

Let compression in tube is  $\delta l_{Al}$  m.

Therefore, the compression in steel bar,  $\delta l_{steel} = \delta l_{Al} + (0.15 \times 10^{-3} \text{ m})$

$$\text{Strain in tube, } \epsilon_{Al} = \frac{\text{Change in length of tube}}{\text{Length of tube}} = \frac{\delta l_{Al}}{(0.5\text{ m} - 0.00015\text{ m})}$$

$$\text{Strain in steel bar, } \epsilon_{steel} = \frac{\text{Change in length of bar}}{\text{Length of bar}} = \frac{\delta l_{Al} + 0.00015\text{ m}}{0.5\text{ m}}$$

$$\begin{aligned} \text{Stress in tube, } \sigma_{Al} &= \epsilon_{Al} \times E_{Al} = \frac{\delta l_{Al}}{(0.5\text{ m} - 0.00015\text{ m})} \times 0.7 \times 10^{11} \text{ N/m}^2 \\ &= (1.4 \times 10^{11}) \delta l_{Al} \text{ N/m}^2 \end{aligned}$$

$$\text{Stress in bar, } \sigma_{steel} = \epsilon_{steel} \times E_{steel} = \frac{\delta l_{Al} + 0.00015\text{ m}}{0.5\text{ m}} \times 2.2 \times 10^{11} \text{ N/m}^2$$

$$\begin{aligned} \text{Total load on assembly} &= \text{Load on tube} + \text{Load on steel bar} = \sigma_{Al} \times A_{Al} + \sigma_{steel} \times A_{steel} \\ 600 \times 10^6 \text{ N} &= (1.4 \times 10^{11}) \delta l_{Al} \text{ N/m}^2 \times 3.436 \times 10^{-3} \text{ m}^2 \end{aligned}$$

$$+ \left[ \frac{\delta l_{Al} + 0.00015\text{ m}}{0.5\text{ m}} \times 2.2 \times 10^{11} \right] \text{ N/m}^2 \times 3.84 \times 10^{-3} \text{ m}^2$$

$$\begin{aligned} 600 \times 10^6 \text{ N} &= 4.81 \times 10^8 \times \delta l_{Al} \text{ N} + (\delta l_{Al} + 0.00015\text{ m}) \times 16.9 \times 10^8 \text{ N} \\ &= (21.71 \times \delta l_{Al} + 0.00253) \times 10^8 \text{ N} \end{aligned}$$

$$\text{or, } \delta l_{Al} = \frac{6 - 0.00253}{21.71} = 0.276 \text{ m}$$

$$\begin{aligned} \text{Hence, stress in tube, } \sigma_{Al} &= (1.4 \times 10^{11}) \delta l_{Al} \text{ N/m}^2 = (1.4 \times 10^{11}) \times 0.276 \text{ N/m}^2 \\ &= 0.386 \times 10^5 \text{ MPa} \end{aligned}$$

$$\begin{aligned} \text{stress in bar, } \sigma_{steel} &= \frac{\delta l_{Al} + 0.00015\text{ m}}{0.5\text{ m}} \times 2.2 \times 10^{11} \text{ N/m}^2 \\ &= \frac{0.276\text{ m} + 0.00015\text{ m}}{0.5\text{ m}} \times 2.2 \times 10^{11} \text{ N/m}^2 = 1.215 \times 10^5 \text{ MPa.} \end{aligned}$$

### EXAMPLE 12.10

A concrete column of  $37.5 \text{ cm}^2$  cross-section, reinforced with steel rods having a total cross-sectional area  $7.5 \text{ cm}^2$  carries a load of  $800 \text{ kN}$  as shown in Figure 12.17:

If  $E$  for steel is 15 times greater than that of concrete, calculate the stresses produced in steel and concrete.



**SOLUTION**

$$E_{\text{steel}} = 15E_{\text{concrete}}$$

$$A_{\text{concrete}} = 37.5\text{ cm}^2 - 7.5\text{ cm}^2 = 30\text{ cm}^2; \quad A_{\text{steel}} = 7.5\text{ cm}^2$$

Contraction in both the steel and concrete will be same.

$$\delta l_{\text{steel}} = \delta l_{\text{concrete}} \quad \text{also,} \quad \epsilon_{\text{steel}} = \epsilon_{\text{concrete}}$$

$$\text{and load,} \quad P = P_{\text{steel}} + P_{\text{concrete}} \quad (12.5)$$

$$\text{Since,} \quad \epsilon_{\text{steel}} = \epsilon_{\text{concrete}}$$

$$\frac{\sigma_{\text{steel}}}{E_{\text{steel}}} = \frac{\sigma_{\text{concrete}}}{E_{\text{concrete}}} \Rightarrow \frac{P_{\text{steel}}}{A_{\text{steel}}E_{\text{steel}}} = \frac{P_{\text{concrete}}}{A_{\text{concrete}}E_{\text{concrete}}}$$

$$\begin{aligned} \text{or,} \quad P_{\text{steel}} &= \frac{A_{\text{steel}}E_{\text{steel}}}{A_{\text{concrete}}E_{\text{concrete}}} \times P_{\text{concrete}} \\ &= \frac{7.5\text{ cm}^2 \times 15E_{\text{concrete}}}{30\text{ cm}^2 \times E_{\text{concrete}}} \times P_{\text{concrete}} \end{aligned}$$

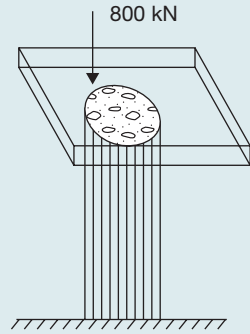
$$\text{or,} \quad P_{\text{steel}} = 3.75P_{\text{concrete}}$$

From Equation (12.5),

$$P = P_{\text{steel}} + P_{\text{concrete}} = 3.75P_{\text{concrete}} + P_{\text{concrete}} = 4.75P_{\text{concrete}}$$

$$P_{\text{concrete}} = \frac{P}{4.75} = \frac{800\text{ kN}}{4.75} = 168.42\text{ kN} \quad \sigma_{\text{concrete}} = P_{\text{concrete}} / A_{\text{concrete}} = 56.14\text{ MN/m}^2$$

$$P_{\text{steel}} = 800\text{ kN} - 168.42\text{ kN} = 631.58\text{ kN} \quad \sigma_{\text{steel}} = P_{\text{steel}} / A_{\text{steel}} = 842.106\text{ MN/m}^2$$


**FIGURE 12.17**

Concrete Column

**12.8 ► STRESS AND STRAIN IN COMPOSITE BAR**

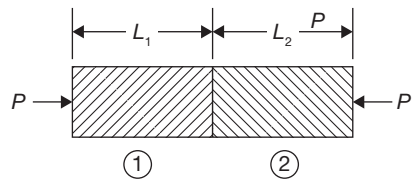
Any tensile or compressive member which consists of two or more bars in series, usually of different materials, is called composite bars (Figure 12.18). In this case, Load on both the rods will be same but strain produced will be different.

$$P = A_1E_1 \epsilon_1 = A_2E_2 \epsilon_2$$

$$\text{Total strain } \epsilon = \frac{P}{A_1E_1} + \frac{P}{A_2E_2}$$

where  $A_1, E_1, \epsilon_1$  are cross-section area, modulus of elasticity, and strain produced in material 1.

Similarly,  $A_2, E_2, \epsilon_2$  are cross-section area, modulus of elasticity, and strain produced in material 2.


**FIGURE 12.18**

Composite Bar

## 12.9 ► TEMPERATURE STRESS

If the temperature of a material is increased, there will be expansion in the material (except ice) and if the temperature is decreased, there will be a contraction in the material. If these expansion and contraction occur freely there will be no stress in the material and if this expansion or contraction is prevented then stress will be set up in the material, which is known as the temperature of thermal stress.

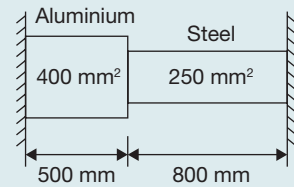
$$\delta l = l_0 \alpha \Delta t$$

where  $\delta l$  is change in length;  $l_0$  is original length;  $\delta$  is coefficient of linear expansion; and  $\Delta t$  is change in temperature.

$$\text{Thermal stress} = E\alpha\Delta t$$

### EXAMPLE 12.11

A composite bar consisting of aluminum and steel components as shown in Figure 12.19, is connected to two grips at the ends at a temperature of  $100^\circ\text{C}$ . Find the stress in the two rods when the temperature falls to  $60^\circ\text{C}$  (i) If ends do not yields, and (ii) if ends yield by 0.5 mm. Assume  $E_{\text{steel}} = 2 \times 10^5 \text{ MPa}$ ,  $E_{\text{Al}} = 0.7 \times 10^5 \text{ MPa}$ ,  $\alpha_{\text{steel}} = 1.17 \times 10^{-5}$  per degree centigrade,  $\alpha_{\text{Al}} = 2.34 \times 10^{-5}$  per degree centigrade. Cross-sectional areas of aluminum and steel bars are 400 and  $250 \text{ mm}^2$ , respectively.



**FIGURE 12.19**

Compositer Bars with Fixed Ends

### SOLUTION

There is a contraction in the bars due to a decrease in temperature. If contraction is free to change in length,

$$\begin{aligned} \Delta l &= l_{\text{Al}} \times \alpha_{\text{Al}} \times \Delta t + l_{\text{st}} \times \alpha_{\text{st}} \times \Delta t = (l_{\text{Al}} \times \alpha_{\text{Al}} + l_{\text{st}} \times \alpha_{\text{st}}) \times \Delta t \\ &= (0.5\text{m} \times 2.34 \times 10^{-5} \text{ per } ^\circ\text{C} + 0.8\text{m} \times 1.17 \times 10^{-5} \text{ per } ^\circ\text{C}) (100^\circ\text{C} - 60^\circ\text{C}) \\ &= 0.8424 \text{ mm.} \end{aligned}$$

When contraction is prevented tensile stresses are produced in the rod.

Loads in two rods will be same.

$$\text{i.e., } \sigma_{\text{Al}} \times A_{\text{Al}} = \sigma_{\text{st}} \times A_{\text{st}} \Rightarrow \sigma_{\text{Al}} = \frac{250\text{mm}}{400\text{mm}} \times \sigma_{\text{st}}$$

**Case I:** When ends do not yeild.

Total contraction = Contraction in aluminum + Contraction in steel

$$\begin{aligned} 0.8424 \times 10^{-3} \text{ m} &= \frac{\sigma_{Al}}{E_{Al}} \times l_{Al} + \frac{\sigma_{st}}{E_{st}} \times l_{st} \\ &= \frac{0.625\sigma_{st}}{0.7 \times 10^{11} \text{ N/m}^2} \times 0.5 \text{ m} + \frac{\sigma_{st}}{2 \times 10^{11} \text{ N/m}^2} \times 0.8 \text{ m} = 8.464 \times 10^{-12} \sigma_{st} \end{aligned}$$

or,  $\sigma_{st} = 0.099 \times 10^9 \text{ N/m}^2 = 99.5 \text{ MPa}$

$$\sigma_{Al} = 0.625\sigma_{st} = 62.2 \text{ MPa}$$

**Case II:** When the ends yeild by 0.5 mm.

Contraction prevented =  $0.8424 - 0.5 = 0.3424 \text{ mm}$

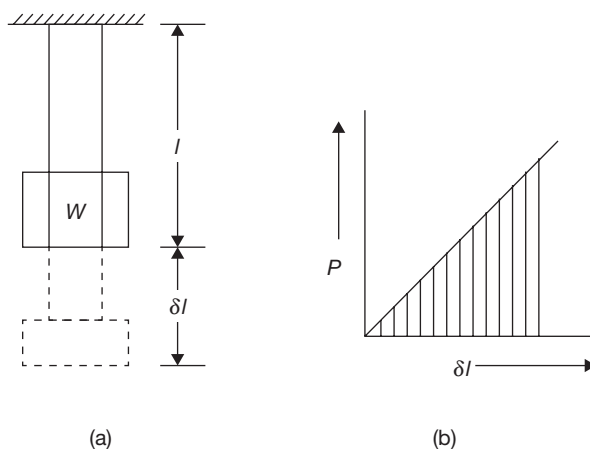
$$0.3424 \times 10^{-3} = 8.464 \times 10^{-12} \sigma_{st}$$

or,  $\sigma_{st} = 40.45 \text{ MPa}$

$$\sigma_{Al} = 25.28 \text{ MPa}$$

## 12.10 ► STRESS AND STRAIN DUE TO SUDDENLY APPLIED LOAD

Suppose  $W$  is a load suddenly applied on the collar of a rod and extension due to the load application is  $\delta l$  as shown in Figure 12.20 (a). The original length of the rod is  $l$ . The work done by the load  $W$  is  $U = W \times \delta l$ .



**FIGURE 12.20**

(a) Suddenly Applied Load  $W$  on a Rod and (b) Load and Deflection Graph for Equivalent Gradually Applied Load

Now consider the equivalent weight for same work is  $P$  which is applied gradually.  
Work done by gradually applied load  $P$  (Figure 12.20 (b)),

$$U = \frac{1}{2} \times P \times \delta l$$

Thus,  $P = 2W$

Hence, gradually applied load for same work done is equal to two times of suddenly applied load.

Stress produced,  $\sigma = \frac{P}{A} = \frac{2W}{A}$  and strain,  $\epsilon = \frac{\delta l}{l} = \frac{P}{AE} = \frac{2W}{AE}$

## 12.11 ► STRESS AND STRAIN FOR IMPACT LOAD

Impact load is a load which is applied to a body with some velocity as shown in Figure 12.21. Suppose a load  $W$  released from a height  $h$  on a collar of a rod of length  $l$  and change in length due to impact loading is  $\delta l$ . Now, work done by impact load  $W$  is

$$U = W(h + \delta l)$$

Suppose the equivalent load for same work done is  $P$ .

Now, work done by equivalent gradual load  $P$

$$U = \frac{1}{2} \times P \times \delta l$$

Thus,  $W(h + \delta l) = \frac{1}{2} \times P \times \delta l$  where  $\delta l = \frac{Pl}{AE}$

or,  $W(h + \delta l) = \frac{1}{2} \times P \times \frac{Pl}{AE}$

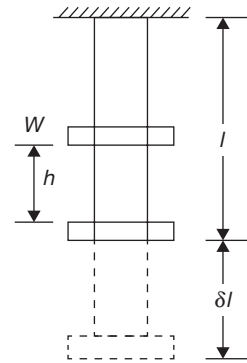
or,  $\frac{P^2 l}{2AE} = W \times h + \frac{W \times P \times l}{AE}$

or,  $P^2 l - 2WPl - 2WhAE = 0$

or,  $p = \frac{2wL + \sqrt{4W^2l^2 + 8WhAE}}{2l} = W \left\{ 1 \pm \sqrt{1 + \frac{2hAE}{Wl}} \right\}$

$$\sigma_{\text{impact}} = \frac{W}{A} \left\{ 1 \pm \sqrt{1 + \frac{2hAE}{Wl}} \right\}$$

Here, -ve sign is neglected since we are interested to find the maximum stress.



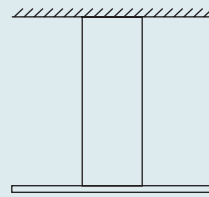
**FIGURE 12.21**

Impact Loading on a Rod

**EXAMPLE 12.12**

A steel rod of 10 mm diameter and of 5 m length has a collar as shown in Figure 12.22:

Find the instantaneous stress and strain when a pull of 200 kN: (i) is gradually applied, (ii) is suddenly applied, and (iii) falls centrally from a height of 120 mm on the collar.  $E = 200 \text{ GN/m}^2$

**FIGURE 12.22**

A Steel Rod with Collar

**SOLUTION**

$$A = \frac{\pi}{4}d^2 = \frac{\pi}{4}(10\text{ mm})^2 = 78.5\text{ mm}^2$$

$$l = 5\text{ m} = 5000\text{ mm}$$

(a) For gradually applied load

$$\sigma = \frac{P}{A} = \frac{200 \times 10^3 \text{ N}}{78.5\text{ mm}^2} = 2.547\text{ N/mm}^2$$

$$\epsilon = \frac{\sigma}{E} = \frac{2.547\text{ N/mm}^2}{2 \times 10^{11} \times 10^{-6}\text{ N/mm}^2} = 1.273 \times 10^{-5}$$

(b) For suddenly applied load

$$\sigma = \frac{2P}{A} = \frac{2 \times 200 \times 10^3 \text{ N}}{78.5\text{ mm}^2} = 5.094\text{ N/mm}^2$$

$$\epsilon = \frac{\sigma}{E} = \frac{5.094\text{ N/mm}^2}{200 \times 10^9 \times 10^{-6}\text{ N/mm}^2} = 2.547 \times 10^{-5}$$

(c) For impact loading

$$\begin{aligned} \sigma_{\text{impact}} &= \frac{P}{A} \left[ 1 + \sqrt{1 + \frac{2hAE}{Wl}} \right] = 2.547\text{ N/mm}^2 \\ &\quad \left[ 1 + \sqrt{1 + \frac{2 \times 120\text{ mm} \times 78.5\text{ mm}^2 \times 200 \times 10^3\text{ N/mm}^2}{200 \times 10^3\text{ N} \times 5000\text{ mm}}} \right] \\ &= 8.108\text{ N/mm}^2 \end{aligned}$$

**12.12 ► RELATION BETWEEN STRESS AND VOLUMETRIC STRAIN**

$$\text{Volumetric strain} = \frac{\text{Change in volume}}{\text{Original volume}} = \frac{\delta V}{V}$$

$$\begin{aligned}\text{But } \epsilon_V &= \epsilon_1 + \epsilon_2 + \epsilon_3 = \frac{1}{E} [\sigma_1 + \sigma_2 + \sigma_3 - 2\nu(\sigma_1 + \sigma_2 + \sigma_3)] \\ &= \frac{1-2\nu}{E} (\sigma_1 + \sigma_2 + \sigma_3)\end{aligned}$$

### 12.13 ► RELATION BETWEEN MODULUS OF ELASTICITY AND BULK MODULUS

Suppose a block is subjected by three-dimensional forces  $P$  as shown in Figure 12.23.

Bulk modulus is a ratio of fluid pressure and volumetric strain. It is denoted by  $K$ .

$$K = \frac{-P}{\delta V/V}$$

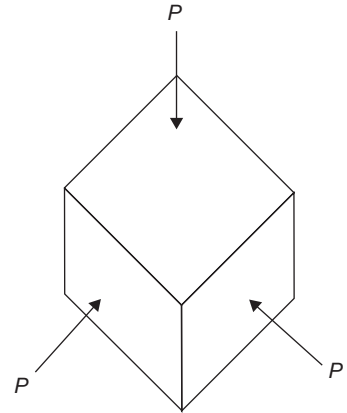
Here -ve sign is used for reduction in volume.

Let us consider a cube of unit length is subjected to fluid pressure  $P$ . It is clear that the principal stresses are  $-P$ ,  $-P$ , and  $-P$  and linear strain in each direction is

$$-\frac{P}{E} - \left(-\frac{\nu P}{E}\right) - \left(-\frac{\nu P}{E}\right) = -(1-2\nu)\frac{P}{E}$$

$$\text{Volumetric strain} = \text{sum of linear strains} = -3(1-2\nu)\frac{P}{E}$$

$$\text{Hence, } K = \frac{-P}{-3(1-2\nu)\frac{P}{E}} \quad \text{or, } E = 3K(1-2\nu) \quad (12.6)$$



**FIGURE 12.23**

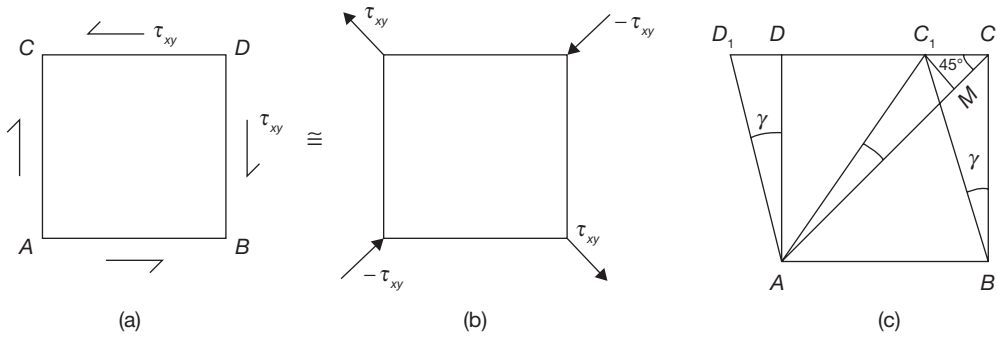
Fluid Pressure and Volumetric Strain of a Cube

### 12.14 ► RELATION BETWEEN MODULUS OF ELASTICITY AND MODULUS OF RIGIDITY

Modulus of rigidity ( $G$ ) is the ratio of shear stress ( $\tau$ ) and shear strain ( $\gamma$ ).

$$G = \frac{\tau}{\gamma}$$

Let us consider an elemental cube ABCD be subjected to a simple shear stress  $\tau_{xy}$  as shown in Figure 12.24 (a). An equivalent system with principal stresses  $\tau_{xy}$  and  $-\tau_{xy}$  are


**FIGURE 12.24**

Shear Stress and Strain on a Cube of Unit Length

acting along the diagonals as shown in Figure 12.24 (b). The distorted condition of the cube is shown in Figure 12.24 (c).

Draw  $C_1M$  perpendicular to  $AC$  and join  $AC_1$

$$\epsilon_{45^\circ} = \frac{\text{Final length of } AC - AC}{AC} = \frac{AC_1 - AC}{AC}$$

Also,  $AC_1 = AM$  (since  $\gamma$  is small)

$$\epsilon_{45^\circ} = \frac{AM - AC}{AC} = -\frac{MC}{AC} = -\frac{CC_1}{\sqrt{2}BC}$$

But,  $CC_1 = \gamma \times BC$  and  $AC = \sqrt{AB^2 + CB^2} = \sqrt{2}BC$

$$\epsilon_{45^\circ} = \frac{\gamma \times BC}{\sqrt{2} \times \sqrt{2}BC} = -\frac{\gamma}{2} = -\frac{\tau_{xy}}{2G} \quad (12.7)$$

Now,  $\epsilon_{45^\circ}$  can also be found by referring to the equivalent system of Figure 12.24 (b) as:

$$\epsilon_{45^\circ} = \frac{1}{E}(\sigma_2 - \nu\sigma_1) \quad \text{or,} \quad \epsilon_{45^\circ} = -\frac{1}{E}(1 + \nu)\tau_{xy}$$

where  $\sigma_1 = +\tau_{xy}$  and  $\sigma_2 = -\tau_{xy}$

From Equation (12.7)

$$\epsilon_{45^\circ} = -\frac{\tau_{xy}}{2G} = -\frac{1}{E}(1 + \nu)\tau_{xy}$$

Hence,  $E = 2G(1 + \nu)$

(12.8)

From Equation (12.6) in previous section and Equation (12.8)

$$E = \frac{9KG}{3K + G}; \text{ Relationship among } E, K, \text{ and } G.$$

**EXAMPLE 12.13**

A bar of 50 mm diameter is subjected to a load of 100 kN. The measured extension on the gauge length of 250 mm is 0.12 mm and the change in diameter is 0.0040 mm. Calculate Poisson's ratio, volumetric strain, and value of three moduli of elasticity.

**SOLUTION**

$$A = \frac{\pi}{4}d^2 = \frac{\pi}{4}(50\text{ mm})^2 = 1963.49\text{ mm}^2$$

$$P = 100\text{ kN}$$

$$\sigma = \frac{P}{A} = \frac{100 \times 10^3\text{ N}}{1963.49\text{ mm}^2} = 50.92\text{ N/mm}^2$$

$$\delta l = 0.12\text{ mm and } l = 250\text{ mm}$$

$$\text{Longitudinal strain} = \frac{0.12\text{ mm}}{250\text{ mm}} = 4.8 \times 10^{-4}$$

$$\text{Original diameter} = 50\text{ mm.}$$

$$\text{Change in diameter} = 0.0040\text{ mm}$$

$$\text{Lateral strain} = \frac{0.004\text{ mm}}{50\text{ mm}} = 8 \times 10^{-5}$$

$$\text{Poisson's ratio} = \nu = -\frac{\text{Lateral strain}}{\text{Longitudinal strain}} = -\frac{8 \times 10^{-5}}{4.8 \times 10^{-4}} = -0.166$$

$$\text{Volumetric strain, } \epsilon_v = \epsilon_1 \times 2 \epsilon_2 = 4.8 \times 10^{-4} + 2 \times 8 \times 10^{-5} = 6.4 \times 10^{-4}$$

$$\text{Modulus of elasticity, } E = \frac{\sigma}{\epsilon_l} = \frac{50.92\text{ N/mm}^2}{4.8 \times 10^{-4}} = 1.06 \times 10^5\text{ N/mm}^2$$

$$E = 2G(1 + \nu)$$

$$= 2G(1 + 0.166) \quad \text{or, } G = 45.490\text{ kN/mm}^2$$

$$E = 3K(1 - 2\nu) \Rightarrow 1.06 \times 10^5\text{ N/mm}^2 = 3K(1 - 2 \times 0.166)$$

$$K = 52.935\text{ kN/mm}^2$$

**EXAMPLE 12.14**

For a given material, Young's modulus is 110 GN/m<sup>2</sup> and shear modulus is 42 GN/m<sup>2</sup>. Find the bulk modulus and lateral contraction of a round bar of 37.5 mm diameter and 2.4 m long when stretched by 2.5 mm.



**SOLUTION**

$$E = 110 \text{ GN/m}^2, \quad G = 42 \text{ GN/m}^2$$

$$E = 2G(1 + \nu) \quad \text{or,} \quad \nu = \frac{E}{2G} - 1 = \frac{110 \text{ GN/m}^2}{2 \times 42 \text{ GN/m}^2} - 1 = 0.3$$

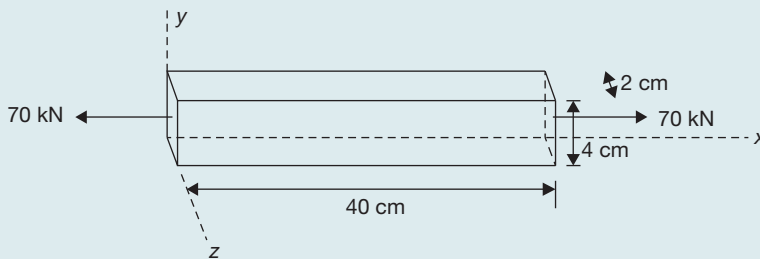
$$E = 3K(1 - 2\nu) \quad \text{or,} \quad K = \frac{E}{3(1 - 2\nu)} = \frac{110 \text{ GN/m}^2}{3(1 - 2 \times 0.3)} = 91.66 \text{ GN/m}^2$$

$$\nu = \frac{\text{Lateral strain}}{\text{Longitudinal strain}} = \frac{\delta d/D}{\delta l/L} = \frac{\delta d \times L}{\delta l \times D}$$

$$\delta d = \frac{\nu \times \delta l \times D}{L} = \frac{0.3 \times 2.5 \text{ mm} \times 37.5 \text{ mm}}{2.4 \times 10^3 \text{ mm}} = 0.0117 \text{ mm.}$$

**EXAMPLE 12.15**

A bar 2 cm × 4 cm in cross section and 40 cm long is subjected to an axial tensile load of 70 kN as show in Figure 12.25. It is found that the length increases by 0.175 mm and a lateral dimension of 4 cm decreases by 0.0044 mm. Find: (i) Young's modulus, (ii) passion's ratio, (iii) change in volume of the bar, and (iv) bulk modulus.

**SOLUTION****FIGURE 12.25**

A Rod Under Tensile Load

Cross-sectional area of bar =  $2 \times 4 = 8 \text{ cm}^2$

$$A_0 = 8 \text{ m}^2; \quad \sigma = \frac{P}{A_0} = \frac{70 \times 10^3 \text{ N}}{8 \text{ cm}^2} = 8.75 \times 10^3 \text{ N/cm}^2 = 87.5 \text{ N/mm}^2$$

$$\epsilon_l = \frac{\delta l}{L} = \frac{0.175 \times 10^{-1} \text{ cm}}{40 \text{ cm}} = 4.4 \times 10^{-4}$$

$$\text{Similarly, } \epsilon_y = \frac{0.00044 \text{ cm}}{4 \text{ cm}} = 1.1 \times 10^{-4}$$

$$(i) E = \frac{\sigma}{\epsilon_l} = \frac{87.5 \text{ N/mm}^2}{4.4 \times 10^{-4}} = 1.98 \times 10^5 \text{ N/mm}^2$$

$$(ii) \nu = \frac{\epsilon_y}{\epsilon_l} = \frac{1.1 \times 10^{-4}}{4.4 \times 10^{-4}} = 0.25$$

$$\nu = 0.25 = \frac{\epsilon_z}{\epsilon_l} = \frac{\delta z / 2}{4.4 \times 10^{-4}} \Rightarrow \delta z = 2 \times 0.25 \times 4.4 \times 10^{-4} = 2.2 \times 10^{-4} \text{ cm}$$

$$(iii) \epsilon_z = \delta z / 2 = 1.1 \times 10^{-4}$$

$$\text{Volumetric strain} = \frac{\Delta V}{V} = \epsilon_l + \epsilon_y + \epsilon_z = (4.4 + 1.1 + 1.1) \times 10^{-4} = 6.6 \times 10^{-4}$$

$$\Delta V = V \times 6.6 \times 10^{-4} = 4 \text{ cm} \times 2 \text{ cm} \times 40 \text{ cm} \times 6.6 \times 10^{-4} = 0.002112 \text{ cm}^3$$

$$(iv) E = 3K(1 - 2\nu) \Rightarrow K = \frac{E}{3(1 - 2\nu)} = \frac{1.98 \times 10^5 \text{ N/mm}^2}{3(1 - 2 \times 0.25)} = 1.32 \times 10^5 \text{ N/mm}^2$$

## RECAP ZONE .....



### Points to Remember

- The **stress** developed in the material is perpendicular to the cross-section, it is known as direct stress and if it is tangential or parallel to the cross-section, it is known as shear stress.
- If the stress distribution along the cross-section is uniform, it is known as simple or **normal stress**.  $\sigma = P/A$ .
- The ratio of lateral to longitudinal strain is constant which is known as **Poisson's ratio** ( $\nu$ ).
- **Volumetric strain**,  $\epsilon_v = \frac{\Delta V}{V}$ ; Superficial strain,  $\epsilon_s = \frac{\Delta A}{A}$ ; where  $\Delta V$  is the change in volume,  $V$  is the original volume,  $\Delta A$  is a change in the area, and  $A$  is the original area.
- **Hook's law** states that stress and strain are perpendicular to each other under the elastic limit.
- The elastic deformation portion of the stress-strain diagram is generally represented as a linear relationship between stress and strain.
- The **elastic limit** is the limit beyond which the material will no longer go back to its original shape when the load is removed.
- **Yield point** is the point at which the material will have an appreciable elongation or yielding without any increase in load.

- The maximum ordinate in the stress-strain diagram is the ultimate strength or tensile strength. Necking starts from this point.
- **Rapture strength** is the strength of the material at rapture point. This is also known as the breaking strength.
- **Modulus of resilience** is the work done on a unit volume of material as the force is gradually increased from zero to elastic limit.
- **Modulus of toughness** is the work done on a unit volume of material as the force is gradually increased from zero to rapture point.
- Working stress is defined as the actual stress of a material under a given loading. The maximum safe stress that a material can carry is termed as the allowable stress.
- The allowable stress should be limited to values not exceeding the proportional limit.
- The ratio of this strength (ultimate or yield strength) to allowable strength is called the factor of safety.
- If the temperature of a material is increased, there will be expansion in the material (except ice) and if the temperature is decreased, there will be a contraction in the material. If these expansion and contraction occur freely there will be no stress in the material and if this expansion or contraction is prevented then stress will be set-up in the material, which is known as the temperature of thermal stress.
- The **principal stress** is the maximum or minimum normal stress in a plane, which is subjected to multidimensional stress, and this plane is known as the principal plane along which shear stress is zero.

## Important Formulae

1. Poisson ratio:  $\nu = -\frac{\text{Lateral strain}}{\text{Longitudinal strain}} = -\frac{\epsilon_y}{\epsilon_x} = -\frac{\epsilon_z}{\epsilon_x}$
2. Modulus of elasticity:  $E = \frac{\sigma}{\epsilon}$
3. Gauge length in the tensile test:  $L_{\text{gauge}} = 5.65\sqrt{A}$
4. Change in length in a stepped bar: Change in length,  $\delta l = \frac{1}{EA} [P_{AB} \times l_{AB} + P_{BC} \times l_{BC} + P_{CD} \times l_{CD}]$
5. Total extension in varying tapered bar,  $\delta l = \frac{4Pl}{\pi D d E}$
6. In compound bars, the extensions or compressions are same in each rod.
7. In composite rods, the stress will be same on each rod.
8. Thermal stress =  $E\alpha\Delta t$
9. In suddenly applied load: Stress produced,  $\sigma = \frac{P}{A} = \frac{2W}{A}$  and strain,  $\epsilon = \frac{\delta l}{l} = \frac{P}{AE} = \frac{2W}{AE}$
10. In impact loading  $\sigma_{\text{impact}} = \frac{W}{A} \left\{ 1 \pm \sqrt{1 + \frac{2hAE}{Wl}} \right\}$
11. Volumetric strain and stress  
 Volumetric strain =  $\frac{\text{Change in volume}}{\text{Original volume}} = \frac{\delta V}{V}$   
 But  $= \epsilon_v = \epsilon_1 + \epsilon_2 + \epsilon_3 = \frac{1}{E} [\sigma_1 + \sigma_2 + \sigma_3 - 2\nu(\sigma_1 + \sigma_2 + \sigma_3)]$   
 $= \frac{1-2\nu}{E} (\sigma_1 + \sigma_2 + \sigma_3)$

12.  $E = 3K(1 - 2\nu)$

13.  $E = \frac{9KG}{3K + G}$

14. Resultant stress in the direction  $\theta$ ,  $\tau_\theta = \frac{\sigma_y - \sigma_x}{2} \sin 2\theta + \tau_{xy} \cdot \cos 2\theta$

15. For Principal Stresses,  $\tau_\theta = 0$ , i.e.,  $\tan 2\theta = \frac{2\tau_{xy}}{\sigma_x - \sigma_y}$

16. Principal stresses:  $\sigma_1 = \frac{\sigma_x + \sigma_y}{2} + \sqrt{\left(\frac{\sigma_x - \sigma_y}{2}\right)^2 + \tau_{xy}^2}$   
 $\sigma_2 = \frac{\sigma_x + \sigma_y}{2} - \sqrt{\left(\frac{\sigma_x - \sigma_y}{2}\right)^2 + \tau_{xy}^2}$

17.  $\tau_{\max} = \sqrt{\left(\frac{\sigma_x - \sigma_y}{2}\right)^2 + \tau_{xy}^2}$

18.  $\tan 2\theta = \frac{-(\sigma_x - \sigma_y)}{2\tau_{xy}}$ ; condition for maximum shear stress

## REVIEW ZONE



### Multiple-choice Questions

- Hook's law holds good up to:
  - Yield point
  - Proportional limit
  - Plastic limit
  - Ultimate point
- Strain is the ratio of:
  - Change in volume to original volume
  - Change in length to original length
  - Change in cross-section area to original cross-section area
  - All of the above
- Deformation per unit length is known as:
  - Linear strain
  - Lateral strain
  - Volumetric strain
  - None of these
- Modulus of rigidity is defined as the ratio of:
  - Longitudinal stress and longitudinal strain
  - Lateral stress and lateral strain
  - Shear stress and shear strain
  - Any one of the above
- Tensile strength of a material is obtained by dividing the maximum load during the test by the:
  - Area at the time of fracture
  - Original cross-section area
  - Average of (a) and (b)
  - Minimum area after fracture
- For steel, the ultimate shear strength in shear in comparison to tension is nearly:
  - Same
  - Half
  - One-third
  - Two-third
- In tensile test of steel, the breaking stress as compared to ultimate stress is:
  - Less
  - More
  - Same
  - None of these
- The value of modulus of elasticity for mild steel is of the order of:
  - $2.1 \times 10^5 \text{ kg/cm}^2$
  - $2.1 \times 10^6 \text{ kg/cm}^2$
  - $2.1 \times 10^7 \text{ kg/cm}^2$
  - $2.1 \times 10^8 \text{ kg/cm}^2$
- The value of Poisson ratio for steel lies between:
  - 0.01–0.1
  - 0.23–0.27
  - 0.25–0.33
  - 0.4–0.6
- The property by which a material returns to its original shape after removal of external load is known as:
  - Elasticity
  - Plasticity
  - Ductility
  - Malleability

11. The materials which exhibit the same elastic properties in all directions are known as:  
 (a) Homogeneous (b) Isotropic  
 (c) Isentropic (d) Inelastic
12. The properties of a material which allows it to be drawn into a smaller section is called:  
 (a) Elasticity (b) Plasticity  
 (c) Ductility (d) Malleability
13. Poisson ratio is defined as:  
 (a) Longitudinal stress/longitudinal strain  
 (b) Longitudinal stress/lateral stress  
 (c) Lateral strain/longitudinal strain  
 (d) Lateral stress/lateral strain
14. The property of material by which it can be rolled into a sheet is known as:  
 (a) Elasticity (b) Plasticity  
 (c) Ductility (d) Malleability
15. In tensile test of mild steel, necking starts from:  
 (a) Proportional limit (b) Plastic limit  
 (c) Ultimate point (d) Rupture point
16. The strain energy stored in a body, when it is strained up to elastic limit is known as:  
 (a) Resilience  
 (b) Proof resilience  
 (c) Modulus of resilience  
 (d) Toughness
17. The maximum strain energy stored in a body is known as:  
 (a) Resilience  
 (b) Proof resilience  
 (c) Modulus of resilience  
 (d) Toughness
18. Proof resilience per unit volume is known as:  
 (a) Resilience  
 (b) Proof resilience  
 (c) Modulus of resilience  
 (d) Toughness
19. The deformation of a bar under its own weight compared to the deformation of the same body subjected to a direct load equal to weight of the body is:  
 (a) Same (b) Half  
 (c) Double (d) One-fourth
20. The tensile stress in a conical rod, having diameter  $D$  at bottom,  $d$  at top, length  $l$  and subjected to tensile force  $F$ , at distance  $x$  from small end will be:  
 (a)  $\frac{4F}{\pi D^2}$  (b)  $\frac{4F}{\pi d^2}$   
 (c)  $\frac{4Fl^2}{\pi((D-d)x + ld)^2}$  (d)  $\frac{4F}{\pi(D-d)^2}$

## Answers

- |         |         |         |         |         |         |
|---------|---------|---------|---------|---------|---------|
| 1. (b)  | 2. (d)  | 3. (a)  | 4. (c)  | 5. (b)  | 6. (b)  |
| 7. (a)  | 8. (b)  | 9. (c)  | 10. (d) | 11. (b) | 12. (c) |
| 13. (c) | 14. (d) | 15. (c) | 16. (a) | 17. (b) | 18. (b) |
| 19. (b) | 20. (c) |         |         |         |         |

## Theory Questions

- Define stress and strain.
- What do you mean by normal stress and shear stress?
- Define longitudinal and lateral strains.
- Define linear, superficial and volumetric strain.
- Define: Young modulus, elastic limit, proportional limit, yield point, ultimate point, breaking point, modulus of rigidity, bulk modulus, and Poisson's ratio.
- Differential engineering strain and true strain.
- State Kook's law.
- Establish relationship between  $E$  and  $K$ .
- Establish relationship between  $E$  and  $G$ .
- Establish relationship between  $E$ ,  $K$  and  $G$ .
- Differentiate compound bar and composite bar.
- Write note on gradual loading, suddenly applied loading, and impact loading.

## Numerical Problems

1. What is the greatest length of a metal wire that can be hung vertically under its own weight? If the allowable stress in the metal of wire is 3 MPa and density of metal is  $12 \times 10^3 \text{ kg/m}^3$ .
2. A steel punch can apply maximum compressive load 1000 kN. Find the minimum diameter of the hole, which can be punched through a 10 mm thick steel plate. Assume ultimate shearing strength of steel plate is  $350 \text{ N/mm}^2$ .
3. A circular rod is tapered from one end to other end; the diameter at one end is 2 cm and the diameter at the other end is 1 cm. Its length is 20 cm long. On applying an axial load of 6 kN, it was found to extend by 0.068 mm. Find the modulus of elasticity of the material of the rod.
4. (a) A uniform bar of length  $L$ , cross-sectional area  $A$ , and unit mass  $\rho$  is suspended vertically from one end. Show that its total elongation is  $d = \rho g L^2 / 2E$ .  
 (b) In the part (a), if the cross-sectional area,  $A = 300 \text{ mm}^2$  and length = 150 m and tensile load applied is 20 kN at the lower end, unit mass of the rod =  $7850 \text{ kg/m}^3$  and  $E = 200 \text{ GPa}$ . Find the total elongation of the rod.
5. A steel rod of 25 mm diameter is placed concentrically in a copper tube of an internal diameter 38.5 mm and external diameter of 41.5 mm. Nuts and washers are fitted on the rod so that the ends of the tube is enclosed by the washers. The nuts are initially tightened to give a compressive stress of  $30 \text{ N/mm}^2$  on the tube and a tensile load of 45 kN is then applied on the rod. Find the resultant stresses in the tie rod and tube,  $E_s = 205 \text{ GPa}$ ,  $E_c = 80 \text{ GPa}$ .

## Learning Objectives

*By the end of this chapter, the student will be able:*

- To understand the function and design of the different types of the springs
- To describe the design and working of cam and followers
- To demonstrate the function of bushing and rolling contact bearings

## SPRINGS

### 13.1 ► INTRODUCTION

Spring is an elastic body whose function is to distort when loaded and to recover its original shape when the load is removed. It works as a flexible joint between two parts or machine elements. It also works as an energy reservoir, it absorbs the energy when loaded and released the same when unloaded.

### Applications of Springs

Springs may be used for various purposes. Some of the important applications of the springs are given below as:

1. *Springs are used for cushioning, absorbing, or controlling of energy due to shock and vibration.* For example: Car springs or railway buffers are used for cushioning effect.
2. *Springs are used to control the motion of machine elements.* For example: spring maintains the contact between two machine elements as in the case of cam and follower. In a cam and follower arrangement, a spring maintains contact between the two elements. It mainly controls the motion of follower with respect to the cam.

3. *Springs are used to create the necessary pressure in a friction device.* For example: In the case of a brake, spring is used to create a pressure by the friction disc on the drum; and similarly, in the case of clutch spring is used to create a pressure between two clutch plates. There are a number of similar applications of the springs in the operations of vehicles, such as the application of springs in valve operation in I.C. Engines and in the case of speed control of the governor and hence the fuel and power control, etc.
4. *Springs are also used to measure the forces.* For example: spring is used in the balance and gauges to measure the forces.
5. *Springs are also used to store the energy.* For example: a spiral spring is used in a mechanical clock to store the energy and release slowly; it is also used in many toys to store the energy.

## 13.2 ► TYPES OF SPRINGS

Spring classification is not fixed; it depends on its applications. Here some commonly used springs are given as:

- (a) Helical Springs—open coiled and close coiled
- (b) Conical and Volute Springs
- (c) Torsion Springs
- (d) Laminated or Leaf Springs
- (e) Disc Springs

### *Helical Springs*

Helical springs are made of a wire coiled in the form of a helix and are primarily used to bear compressive or tensile loads. The cross-section of wire from which the spring is made may be circular, square or rectangular. The two forms of helical springs are compression helical spring and tension helical spring as shown in Figure 13.1. Open coiled helical springs are used for bearing the compressive load. The helix angle in the case of open coiled helical spring may be larger, i.e., more than  $15^\circ$ . Close coiled helical spring is used for tensile load and the helix angle, in this case, may vary from  $5^\circ$  to  $10^\circ$ .

### *Conical and Volute Springs*

The conical and volute spring, as shown in the Figure 13.2, are used in special applications where the spring rate increases in an increase in load. Another feature of these types of springs is the decreasing number of coils results in an increasing spring rate. This characteristic is sometimes utilized in vibrations problems where springs are used to support the body that have varying mass. The shape of the volute spring is paraboloid with a constant pitch.



**Torsion Springs**

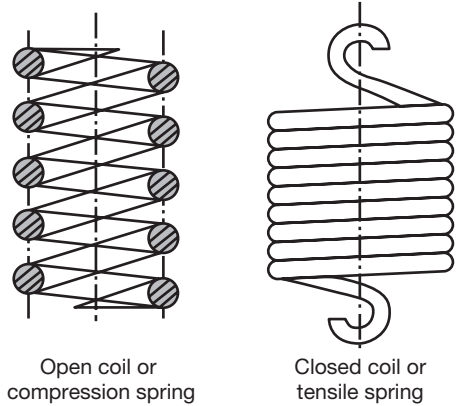
Torsion springs may be of the helical or spiral type as shown in Figure 13.3 and used to apply torsion. Helical types of springs are used where the load tends to wind up the springs and are used in some electrical mechanisms. Spiral type is used where the loads tend to increase the number of coils and are used in watches and clocks.

**Laminated or Leaf Springs**

The laminated or leaf spring is also known as flat spring as shown in the Figure 13.4. It consists of a number of flat plates, known as leaves, of varying lengths held together by means of clamps and bolts. These types of springs are most used in automobiles on the axle to bear the load of the vehicle and minimize the jerk.

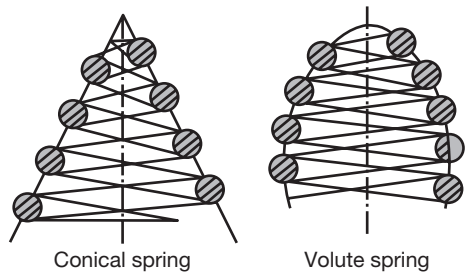
**Disc Spring**

These springs consist of a number of conical discs held together by a central bolt or tube as shown in the Figure 13.5. These springs are used in applications where high spring rates and compact spring units are required.



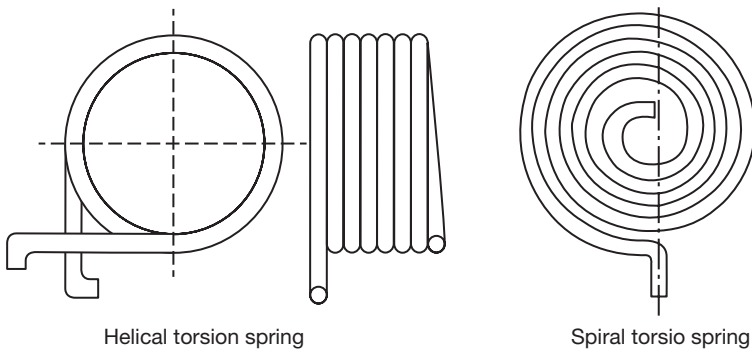
**FIGURE 13.1**

Helical Springs



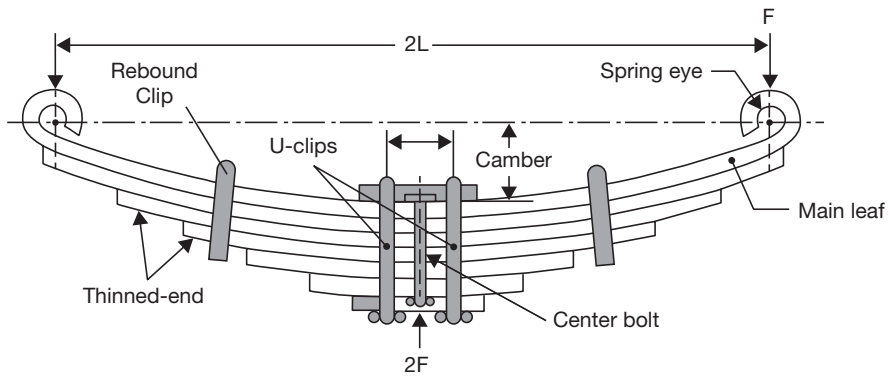
**FIGURE 13.2**

Conical and Volute Springs

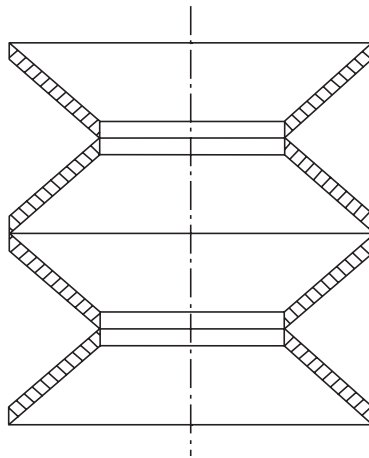


**FIGURE 13.3**

Torsion Spring

**FIGURE 13.4**

Leaf Spring

**FIGURE 13.5**

Disc Spring

### 13.3 ► MATERIALS USED FOR SPRINGS

Some of the common materials used for spring manufacturing are given below.

**Hard-drawn Wire:** This is cold drawn, cheapest spring steel and used for low stress and static load. The material is not suitable at subzero temperatures or at temperatures above  $1200^{\circ}\text{C}$ . Subzero temperature means the temperature below zero degree Fahrenheit.

**Oil-tempered Wire:** It is a cold drawn, quenched, tempered, and general purpose spring steel, but not suitable for fatigue or sudden loads, at subzero temperatures and at temperatures above  $1800^{\circ}\text{C}$ . Alloy steels are more useful for highly stressed conditions.

**Chrome Vanadium:** This alloy spring steel is used for high-stress conditions and at high-temperature, up to 2200°C. It is good for fatigue resistance and long endurance for shock and impact loads.

**Chrome Silicon:** This material can be used for highly stressed springs. It offers good service for long life, shock loading and for temperature up to 2500°C.

**Music Wire:** This spring material is most widely used for small springs. It is the toughest and has high tensile strength and can withstand repeated loading at high stresses. However, it cannot be used at subzero temperatures or at temperatures above 1200°C. Normally when we talk about springs we will find that the music wire is a common choice for springs.

**Stainless Steel:** It is generally used as alloy spring materials.

**Phosphor Bronze/Spring Brass:** It is corrosion resistant and electrical conductor. It is commonly used for contacts in electrical switches. Spring brass can be used at subzero temperatures.

### 13.4 ► SHEAR STRESS IN HELICAL SPRINGS

**Solid Length:** The solid length of a spring is the product of a total number of coils and the diameter of the wire. It is the length when the springs are compressed until the coils come in contact with each other. Mathematically,

**Solid length =  $n \times d$ ;** where 'n' is the number of coils in the spring and 'd' is the diameter of the spring wire.

**Free Length:** Free length of a compression spring is the length of the spring in the free or unloaded condition and is equal to the solid length plus the maximum deflection or compression of the spring and the clearance between the adjacent coils.

*Free length,  $L_f = \text{solid length} + \text{max. deflection} + \text{clearance between adjacent coils}$ .*

**Spring Index:** It is defined as the ratio of the mean diameter of the coil to the diameter of the wire.

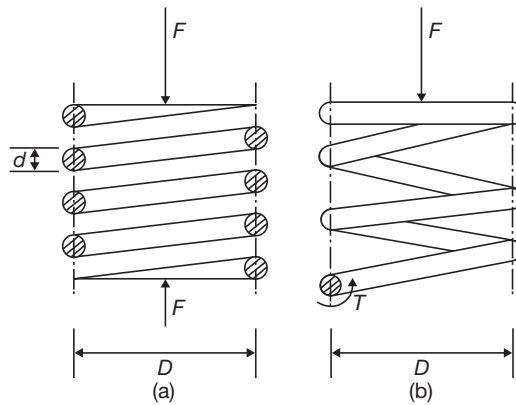
*Spring index,  $C = D/d$ ;* where 'D' is the mean diameter of the coil and 'd' is the diameter of the wire.

**Spring Rate:** Spring rate (stiffness/spring constant) is defined as the load required per unit deflection of the spring.

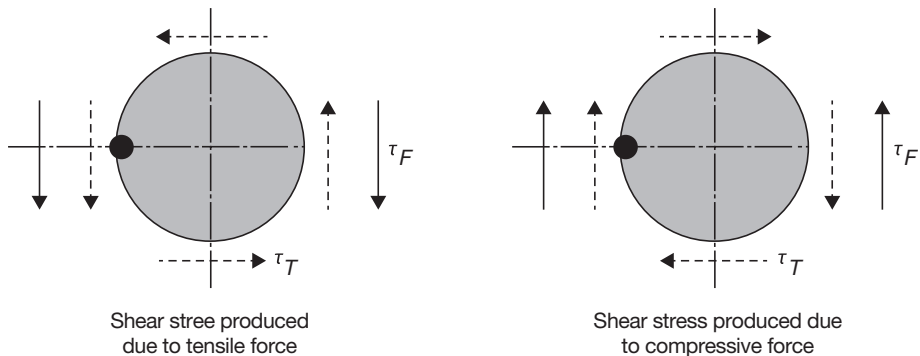
*Spring Rate,  $k = F/\delta$ ;* where F is the load applied and  $\delta$  is the deflection.

**Pitch:** Pitch of the coils is defined as the axial distance between adjacent coils in the uncompressed state.

Let us consider an open coiled helical spring is subjected an axial compressive load, F as shown in the Figure 13.6. The shear stress will be induced in the wire. The shear stress will be due to axial force, F and also due to the torsion produced in the wire of the spring.

**FIGURE 13.6**

(a) Open Coiled Spring under Axial Load,  
 (b) Free Body Diagram of Open Coiled Spring under Axial Load.

**FIGURE 13.7**

Shear Stress Produced in the Wire of the Helical Spring

Due to axial loading, the wire will be subjected to shear forces produced due to axial loading and the torque induced as shown in Figure 13.7.

If the diameter of the spring is  $D$ , the torque produced in the spring will be  $T = F \times \frac{D}{2}$   
 If the wire diameter is  $d$ , the polar moment of inertia will be

$$I_p = \frac{\pi d^4}{32}$$

Shear stress in the spring wire due to torsion,  $T$  will be

$$\tau_T = \frac{T \times r}{I_p} = \frac{F \times \frac{D}{2} \times \frac{d}{2}}{\frac{\pi d^4}{32}} = \frac{8FD}{\pi d^3}$$

Shear stress in the spring wire due to force  $F$  will be

$$\tau_F = \frac{F}{\frac{\pi d^2}{4}} = \frac{4F}{\pi d^2}$$

The maximum shear stress in the spring wire will be

$$\begin{aligned} \tau_{\max} &= \tau_T + \tau_F = \frac{8FD}{\pi d^3} + \frac{4F}{\pi d^2} \\ &= \frac{8FD}{\pi d^3} \left( 1 + \frac{1}{\frac{2D}{d}} \right) = \frac{8FD}{\pi d^3} \left( 1 + \frac{1}{2c} \right) \\ &= K_s \frac{8FD}{\pi d^3}; \end{aligned}$$

Where  $K_s = 1 + \frac{1}{2c}$

### Stresses in Helical Spring with Curvature Effect

Wahl correction factor is used in the above expression for consideration of curvature factor and shear stress correction factor as:

$$\tau_{\max} = K_w \frac{8FD}{\pi d^3}$$

where  $K_w$  (Wahl correction factor) =  $\frac{4C-1}{4C-4} + \frac{0.615}{C}$

## 13.5 ► DEFLECTION IN HELICAL SPRING

Let  $l$  = total active length of wire =  $\pi D \times n$

$\theta$  = Angular deflection of the wire due to Torque,  $T$ .

Therefore, Axial deflection of the spring  $\delta = \theta \times D/2$

We know that  $\theta = \frac{T \times l}{I_p \times G}$ ; where  $G$  is the modulus of rigidity.

$$\theta = \frac{\left(F \times \frac{D}{2}\right) \pi D n}{\frac{\pi}{32} \times d^4 G} = \frac{16F.D^2.n}{G.d^4}$$

$$\text{Now, } \delta = \theta \times D/2 = \frac{16F.D^2.n}{G.d^4} \times \frac{D}{2} = \frac{8F.D^3.n}{G.d^4}$$

$$\text{Stiffness of the spring, } k = \frac{F}{\delta} = \frac{G.d^4}{8D^3.n} = \frac{G.d}{8C^3.n}$$

### EXAMPLE 13.1

A close coiled helical spring has to absorb 80 Nm of energy when compressed 8 cm. The coil diameter is six times the wire diameter. If there are 10 coils, estimate the diameters of coil and wire and the maximum shear stress.  $G = 85,000 \text{ N/mm}^2$ .

### SOLUTION

Given  $U = 80 \text{ Nm}$ ,  $x = 8 \text{ cm} = 80 \text{ mm}$ ,  $C = 6$ ,  $n = 10$  and  $G = 85,000 \text{ Nm}$ .

$$U = \frac{1}{2} F \delta \Rightarrow F = \frac{2U}{\delta} = \frac{2 \times 80 \text{ Nm}}{0.08 \text{ m}} = 2000 \text{ N}$$

$$\delta = \frac{8F.D^3.n}{G.d^4}$$

or 
$$\delta = \frac{8F.n}{G.d} \left( \frac{D^3}{d^3} \right) = \frac{8F.C^3.n}{G.d}$$

$$d = \frac{8 \times 2000 \text{ N} \times 6^3 \times 10}{85000 \text{ N/mm}^2 \times 80 \text{ mm}} = 5.082 \text{ mm}$$

$$D = 6 \times d = 6 \times 5.082 \text{ mm} = 30.5 \text{ mm}$$

$$\begin{aligned} \tau_{\max} &= \tau_T + \tau_F = \frac{8FD}{\pi d^3} \left( 1 + \frac{1}{2c} \right) = K_S \frac{8FD}{\pi d^3} \\ &= \frac{8 \times 2000 \text{ N} \times 30.5 \text{ mm}}{3.14 \times (5.082 \text{ mm})^3} \times 1.083 = 1282.373 \text{ N/mm}^2 \end{aligned}$$

**EXAMPLE 13.2**

A close-coil helical spring is to have a stiffness of 1,000 N/m in compression, with a maximum load of 50 N and a maximum shearing stress of 125 N/mm<sup>2</sup>. The solid length of the spring is 50 mm. Find the wire diameter, mean coil radius, and a number of coils.  $G = 54,000 \text{ N/mm}^2$ . (Assume shear stress is produced only due to the torque produced in the wire due to axial loading).

**SOLUTION**

$$k = \frac{F}{\delta} = \frac{G.d^4}{8D^3.n} = \frac{G.d}{8C^3.n}$$

$$1000 \times 10^{-3} \text{ N/mm} = \frac{54,000 \text{ N/mm}^2 \times d^4}{8D^3.n} \quad \text{or,} \quad d^4 = \frac{4}{27 \times 10^3} D^3.n \quad (13.1)$$

$$\text{Maximum stress, } \tau_{\max} = \frac{8FD}{\pi d^3}$$

$$125 \text{ N/mm}^2 = \frac{8 \times 50 \text{ N} \times D}{\pi d^3}$$

$$D = 1.962d^3 \quad (13.2)$$

$$\text{Solid length} = nd$$

$$50 = nd \quad (13.3)$$

From Equation (13.1) and (13.2)

$$d^4 = \frac{4}{27 \times 10^3} (1.962d^3)^3 \frac{50}{d}$$

$$d^4 = \frac{27 \times 10^3}{4 \times (1.962)^3 \times 50}; \quad d = 2.05 \text{ mm}$$

$$n = 50/d = 25; \quad D = 1.962d^3 = 16.9 \text{ mm}$$

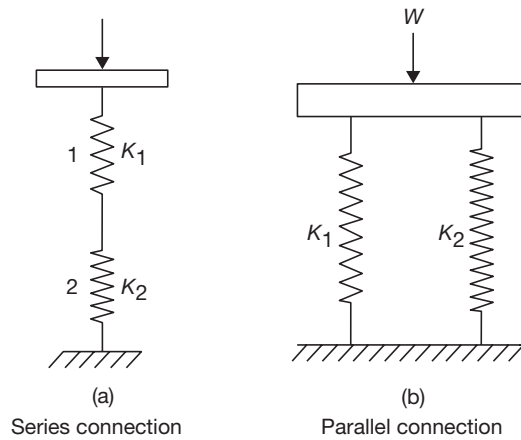
**13.6 ► SERIES AND PARALLEL CONNECTION OF HELICAL SPRINGS**

The series connection and parallel connection of the helical springs are shown in the Figure 13.8. For series connection, the equivalent spring stiffness is calculated as:

$$\delta = \delta_1 + \delta_2 \quad \text{or,} \quad \frac{F}{k_e} = \frac{F}{k_1} + \frac{F}{k_2} \quad \text{or,} \quad k_e = \frac{k_1 k_2}{k_1 + k_2}$$

For parallel connection, the equivalent spring stiffness is calculated as:

$$W = W_1 + W_2 \quad \text{or,} \quad k_e \delta = k_1 \delta + k_2 \delta \quad \text{or,} \quad \delta = \delta_1 + \delta_2$$

**FIGURE 13.8**

Series and Parallel Connection of Helical Springs

**EXAMPLE 13.3**

A composite spring has two close coiled helical springs connected in series; each spring has twelve coils at a mean diameter of 20 mm. Find the wire diameter in one if the other is 2 mm and the stiffness of the composite spring is 600 N/m. Estimate the greatest load can be carried out by the composite spring, and the corresponding extension, for a maximum shearing stress of 160 N/mm<sup>2</sup>.  $G = 75,000$  N/mm<sup>2</sup>.

**SOLUTION**

For series connection

$$\delta = \delta_1 + \delta_2$$

$$\frac{F}{k} = \frac{F}{k_1} + \frac{F}{k_2} \quad \text{or} \quad \frac{1}{k} = \frac{1}{k_1} + \frac{1}{k_2} = \frac{8D^3n}{Gd_1^4} + \frac{8D^3n}{Gd_2^4}$$

$$\frac{10^3}{600} = \frac{8 \times (20\text{mm})^3 \times 12}{75,000\text{N/mm}^2 \times (2\text{mm})^4} + \frac{8 \times (20\text{mm})^3 \times 12}{75,000\text{N/mm}^2 \times d_2^4}$$

$$\frac{10.24}{d_2^4} = 1.667 - 0.64$$

$$d_2 = 1.77 \text{ mm}$$

$$F = \frac{\pi \times d_2^3 \times \tau_{\max}}{8D} = \frac{\pi \times (1.77\text{mm})^3 \times 160\text{N/mm}^2}{8 \times 20\text{mm}} = 17.41\text{N}$$

$$\text{Total extension} = \frac{F}{k} = \frac{17.41\text{N}}{0.6\text{N/mm}} = 29.01\text{mm}$$



## CAM AND FOLLOWER

### 13.7 ► INTRODUCTION

The linkages of the cam and follower work are used to transmit the motion from one link to another. A cam is a rotating component in a mechanical linkage that drives the mating component, i.e., follower. The transmitted motion may be reciprocating, linear, simple harmonic motion, etc.

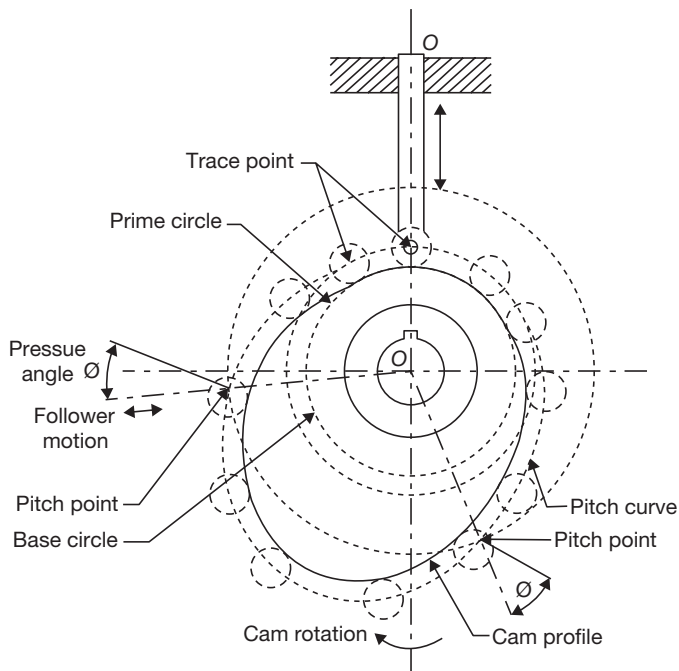
### Cam Nomenclature

The different part of the cam and follower are shown in the Figure 13.9.

**Cam Profile:** Cam profile is the outer surface of the disc cam.

**Base Circle:** Base circle is the smallest circle, drawn tangential to the cam profile.

**Tracepoint:** Tracepoint is a point on the follower, trace point motion describes the movement of the follower.



**FIGURE 13.9**

Cam Nomenclature

**Pitch Curve:** Pitch curve is the path generated by the tracepoint as the follower is rotated about a stationary cam.

**Prime Circle:** Prime Circle is the smallest circle that can be drawn so as to be tangential to the pitch curve, with its center at the cam center.

**Pressure Angle:** The pressure angle is the angle between the direction of the follower movement and the normal to the pitch curve.

**Pitch Point:** Pitch point corresponds to the point of maximum pressure angle.

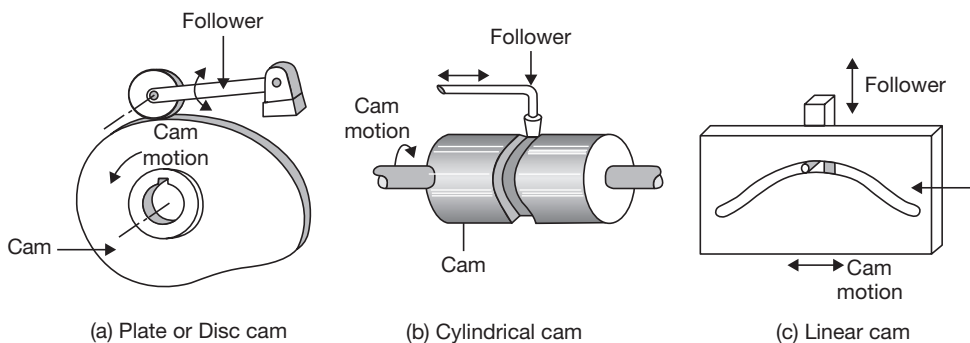
**Pitch Circle:** A circle drawn from the cam center and passes through the pitch point is called Pitch circle.

**Stroke:** The greatest distance or angle through which the follower moves or rotates.

## 13.8 ► TYPES OF CAMS

Cams can be classified into the following three types based on their shapes:

1. **Plate or Disk Cams:** Plate or disk cams are the simplest and most commonly used type of cam. A plate cam is illustrated in Figure 13.10 (a). This type of cam is formed on a disk or plate. The radial distance from the center of the disk is varied throughout the circumference of the cam. Allowing a follower to ride on this outer edge gives the follower a radial motion.
2. **Cylindrical or Drum Cam:** A cylindrical or drum cam is shown in Figure 13.10 (b). This type of cam is formed on a cylinder. A groove is cut into the cylinder, with a varying location along the axis of rotation. Attaching a follower that rides in the groove gives the follower motion along the axis of rotation.



**FIGURE 13.10**

Type of Cams

3. **Linear Cam:** A *linear cam* is illustrated in Figure 13.10 (c). This type of cam is formed on a translated block. A groove is cut into the block with a distance that varies from the plane of translation. Attaching a follower that rides in the groove gives the follower motion perpendicular to the plane of translation.

## 13.9 ► TYPES OF FOLLOWERS

Followers are classified based on their motion, position, and shape. The details of followers classifications are shown in the Figure 13.11 and discussed below:

### 1. Based on Follower Motion

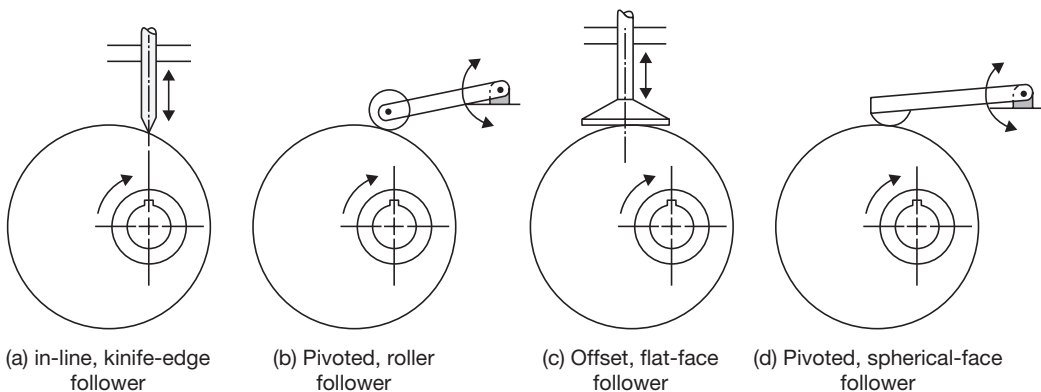
Based on the follower motion, followers can be classified into the following two categories:

- (i) *Translating followers:* They are constrained to motion in a straight line and are shown in Figure 13.11 (a) and (c).
- (ii) *Swinging arm or pivoted followers:* They are constrained to rotational motion and are shown in Figure 13.11 (b) and (d).

### 2. Based on Follower Position

Based on the position of the follower relative to the center of rotation of the cam, followers can be classified into the following two categories:

- (i) An *in-line follower* that exhibits straight-line motion in such a way that the line of translation extends through the center of rotation of the cam and is shown in Figure 13.11 (a).



**FIGURE 13.11**

Type of Followers

- (ii) An *offset follower* that exhibits straight-line motion in such a way that the line of the motion is offset from the center of rotation of the cam and is shown in Figure 13.11 (c).

In the case of pivoted followers, there is no need to distinguish between in-line and offset followers because they exhibit identical kinematics.

### 3. Based on Follower Shape

Finally, the follower shape can be classified into the following four categories:

- (i) A *knife-edge follower* that consists of a follower formed into a point shape and drags on the edge of the cam. The knife-edge follower is shown in Figure 13.11 (a). It is the simplest form, but the sharp edge produces high contact stresses and wears rapidly. Consequently, this type of follower is rarely used.
- (ii) A *roller follower* that consists of a follower having roller as a separate part and is pinned to the follower stem. The roller follower is shown in Figure 13.11 (b). As the cam rotates, the roller maintains contact with the cam and rolls on the cam surface. This is the most commonly used follower, as the friction and contact stresses are lower than those for the knife-edge follower. However, a roller follower can possibly jam during steep cam displacements.
- (iii) A *flat-faced follower* that consists of a follower formed with a large flat surface available to contact the cam. The flat-faced follower is shown in Figure 13.11 (c). This type of follower can be used with a steep cam motion and does not jam. Consequently, this type of follower is used when quick motions are required. However, any follower deflection or misalignment causes high surface stresses. In addition, the frictional forces are greater than those of the roller follower because of the intense sliding contact between the cam and follower.
- (iv) A *spherical-faced follower* that consists of a follower formed with a radius face and contacts the cam. The spherical-face follower is shown in Figure 13.11 (d). As with the flat-faced follower, the spherical-face can be used with a steep cam motion without jamming. The radius face compensates for deflection or misalignment. Yet, like the flat-faced follower, the frictional forces are greater than those of the roller follower.

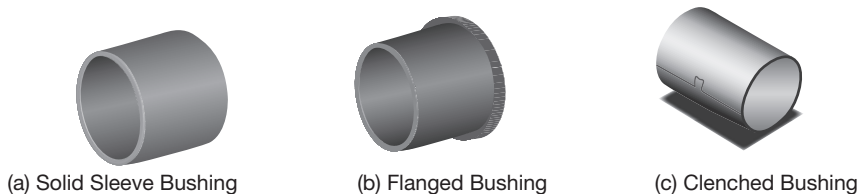
#### Limits Imposed on the Shape of the Cam Working Surface by the Choice of Follower Type.

- ▶ The knife follower does not, theoretically, impose any limit on the shape of the cam.
- ▶ The roller follower demands that any concave portion of the working surface must have a radius at least equal to the radius of the roller.
- ▶ The flat follower requires that everywhere the surface of the cam is convex.

## BUSHING AND ROLLER BEARING

### 13.10 ► INTRODUCTION

A bush bearing or bushing is the most common form of a plain bearing. It is inserted into a housing to provide a bearing surface for rotary applications. Its a common form of the design includes *solid* (sleeve and *flanged*), *split*, and *clenched* bushings as shown in Figure 13.12. A sleeve, split, or clenched bushing is a sleeve of the length ( $L$ ), an inner diameter ( $D_i$ ), and outer diameter ( $D_o$ ). The difference between the three types bushing is that a solid sleeved bushing is solid all the way around, a split bushing has a cut along its length, and a clenched bearing is similar to a split bushing but with a clench across the cut. A flanged bushing has a flange at one end extending radially outward. The flange is used to positively locate the bushing when it is installed or to provide a thrust bearing surface.



**FIGURE 13.12**

Sleeve Bushings

A bi-material bearing consists of two materials, a metal shell, and a plastic bearing surface. Common combinations include a steel-backed PTFE-coated bronze and aluminum-backed Frelon. PTFE or polytetrafluoroethylene has unique properties. PTFE coating is also known as Teflon, Xylan, Fluoroplastic, or fluorocarbon coating, and is normally applied to components where a non-stick, dry lubricant or low-friction coating is required. Frelon is a polytetrafluoroethylene based material with other proprietary fillers to increase the bearing characteristics.

### 13.11 ► BUSHING MATERIALS

**Bronze:** A common plain bearing design utilizes a hardened and polished steel shaft and a softer bronze bushing. The bushing is replaced whenever it has worn too much.

**Cast iron:** A cast iron bearing can be used with a hardened steel shaft because the coefficient of friction is relatively low. The cast iron glazes over therefore wear becomes negligible.

**Graphite:** A copper and graphite alloy, commonly known as graphalloy, is commonly used in oven and dryers. The graphite is a dry lubricant; therefore it has low friction and requires low maintenance. The copper provides strength, durability, and heat dissipation characteristics.

## Application of Lubrication in Bushing

The following types of lubrications are used in bushings:

**Class I:** The bearings that require the application of a lubricant from an external source (e.g., oil, grease, etc.).

**Class II:** The bearings that contain a lubricant within the walls of the bearing (e.g., Bronze, Graphite, etc.). Typically these bearings require an outside lubricant to achieve maximum performance.

**Class III:** The bearings made of self-lubricating materials. These bearings can run without an external lubricant.

### 13.12 ► BEARINGS

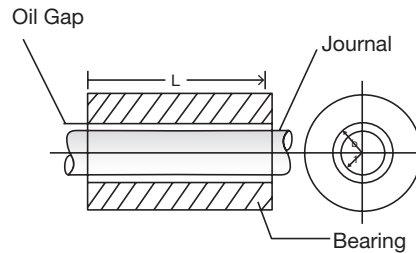
Broadly, there are two types of bearings, one is sliding contact or bush bearing and another is rolling contact bearing.

#### 13.12.1 Sliding Contact or Bush Bearings

These bearings are also called as ‘Journal bearings’ or ‘Bush bearings’. A sliding contact bearing is shown in Figure 13.13.

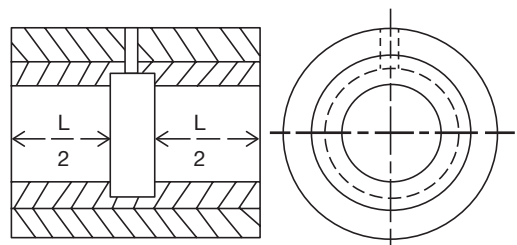
The shaft (called journal) is mounted inside a hollow cylinder (called bearing). When the journal rotates, there is a relative motion between surfaces of journal and bearing. Placing lubricant between the journal and the inner surface of the bearing can reduce the friction resisting the relative motion between journal and bearing. The journal bearings are used to support the load in the radial direction. Generally, the journal rotates while the bearing is stationary. In some cases, the bearing rotates and the journal is stationary. In few cases, both the bearing and journal rotate.

Oil grooves are constructed on journal bearings either by circumferential or cylindrical patterns. A circumferential oil groove bearing is shown in Figure 13.14.



**FIGURE 13.13**

Bush Bearing

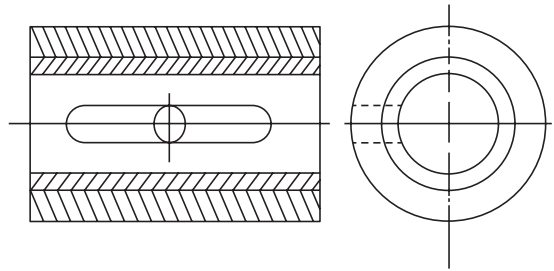


**FIGURE 13.14**

Circumferential Oil-groove Bearing

The oil groove divides the bearings into two short bearings in the axial direction, each of length  $(L/2)$ . The presence of groove reduces the pressure developed in the fluid in the plane of groove considerably, as well as the overall pressure. This reduces the load carrying capacity of bearing. Further, the centrifugal force acting on the oil in the circumferential groove may build pressure higher than the supply pressure, restricting the flow of the lubricant into the bearing. These bearings find application in automobiles.

The cylindrical oil-groove bearing is shown in Figure 13.15. The bearing has an axial groove along the full length of bearing. It has higher load carrying capacity compared to the circumferential oil groove bearing. It is more susceptible to vibrations. It is used for gearboxes and high-speed applications. Different patterns of oil grooves are also made by a combination of cylindrical and circumferential grooves.



**FIGURE 13.15**

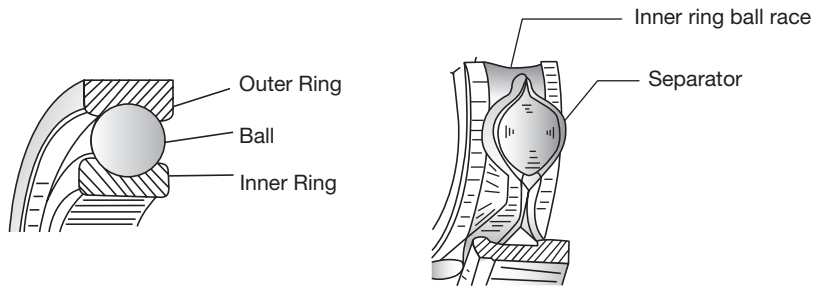
Cylindrical Groove Bearing

### 13.12.2 Rolling Contact Bearings

A rolling contact bearing is called as 'anti-friction bearing'. It is an assembly of rolling elements (balls or rollers) placed between the shaft and housing, maintaining radial space between them. The bearing has usually two rings with hardened raceways (outer and inner races), in between hardened steel balls or rollers roll. These balls or rollers are called 'rolling elements' and are held in an angularly spaced relationship by a cage or separator. The rolling contact bearing can be classified into ball bearings and roller bearings based on the geometry of the sliding elements. Rolling contact bearings are used to carry radial or thrust loads or the combination of both. Rolling contact bearings are lubricated with grease.

#### A. Ball Bearing

The nomenclature of the ball bearing is shown in Figure 13.16. The bearing consists of four parts: the outer ring, inner ring, the balls and the separators. The separators prevent the balls from colliding with each other. For the successful design of bearing, the conformity of the ball radius to the raceways radii is very important. Increasing the conformity (i.e., the radius of the ball is increased so that it is closer to the radii of the curvatures of the raceways) increases the area of contact between the balls and raceway. This increases the friction. However, the unit surface stress on the ball is reduced which in turn supports a greater load. Thus, the selection of curvatures for the raceways is a matter of design compromise between friction and load. Most commercial bearings have inner and outer raceways curved to radii between 51.5 and 53% of ball diameter. When the bearing is loaded, elastic and plastic deformations of the balls and raceways increases the conformity; then the balls do not have

**FIGURE 13.16**

Nomenclature of Ball Bearing

pure rolling motion. As a result, a small amount of sliding always occurs between the balls and raceways, which affect both the frictional loss and life of bearing.

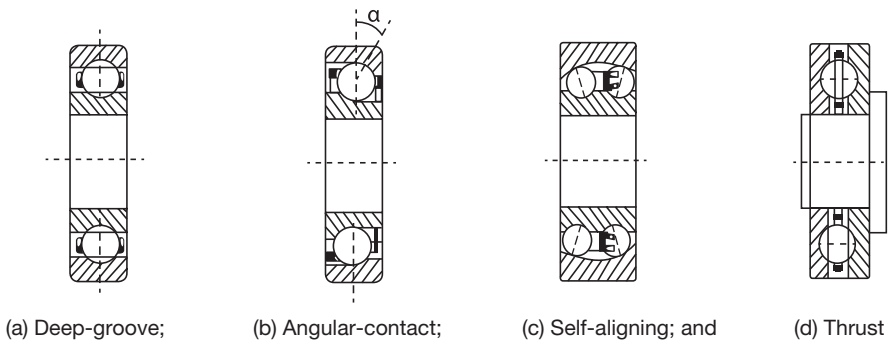
### TYPES OF BALL BEARINGS

Mainly four types of ball bearings are commonly used. These are deep-groove, angular-contact, self-aligning, and thrust ball bearings as shown in Figure 13.17.

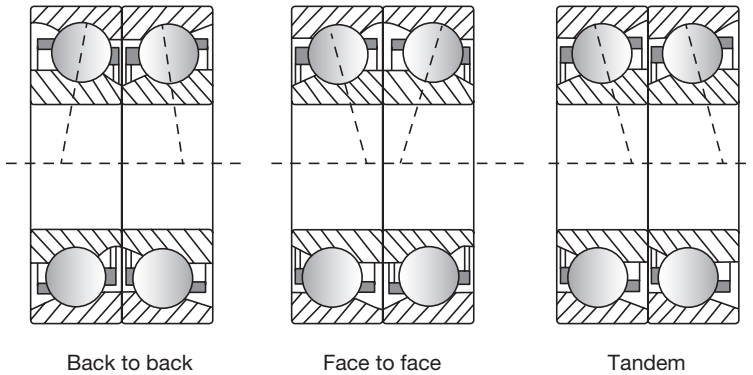
**Deep-groove Ball Bearing:** The widely used ball bearing to support radial load is Deep-Groove ball bearing as shown in Figure 13.17 (a). They are mainly designed to support the high radial load and moderate thrust load. They have deep raceways that are continuous (i.e., there are no openings or recesses) over all of the ring circumferences. This type of construction permits the bearings to support relatively high thrust load in either direction. In fact, the thrust load capacity is about 70% of the radial load capacity. It is designed to support radial load can also support high thrust load; because only a few balls carry the radial load, whereas all the balls can withstand the thrust load. In the case of the double-row deep-groove ball bearings, it has two rows of balls rolling in two pairs of races. They have more radial load capacity than that of single row bearings. In other words, they are smaller in diameter compared to single row ball bearings for comparable radial load capacity. However, the proper load sharing between the balls mainly depends on the accuracy of manufacturing.

**Angular Contact Bearings:** The angular contact bearings as shown in Figure 13.17 (b) are designed in such a way that the centerline of contact between balls and raceways is at an angle to a plane perpendicular to the axis of rotation. This angle is called contact angle. The angular contact ball bearing may be of single or two rows of balls. They are used to carry radial and axial load together or only axial load depending on the magnitude of the angle of contact. The bearings having large contact angle support heavy thrust. The groove curvature radii are generally 52 to 53% of ball diameter. Angular contact single row ball bearings have high radial-load and high unidirectional thrust load capacity than the deep groove ball bearings.





**FIGURE 13.17**  
Types of Ball Bearings



**FIGURE 13.18**  
Duplex Angular Contact Ball Bearing

The contact angle is usually less than  $40^\circ$ . In the case of angular contact ball bearings, one side of the outer race is cut to insert balls. This permits the bearing to take the thrust load in only one direction. Therefore, single row angular contact ball bearings are generally used in pairs. In the case of double row angular contact ball bearings (duplex), the balls can be arranged ‘back to back’ and ‘face to face’ or ‘tandem’ configurations (Figure 13.18). The back to back and face to face duplex bearings can accommodate radial load and axial loads in both directions. The tandem bearings can accommodate radial load and heavy axial load in only one direction.

**Self-aligning Ball Bearings:** For assembly of shaft and housing which cannot be made perfectly coaxial, the self-aligning ball bearings are the best used. They consist of two rows of balls on a common spherical outer race (Figure 13.17 (c)). In such bearings, the assembly of

inner ring and balls can tilt in the outer ring. The loss of load-carrying capacity is inherent in this construction, due to nonconformity of outer raceway with the balls. This is compensated by having a large number of balls in the bearings. Self-aligning ball bearings are used in top drafting rollers and the main shaft of ring spinning machine.

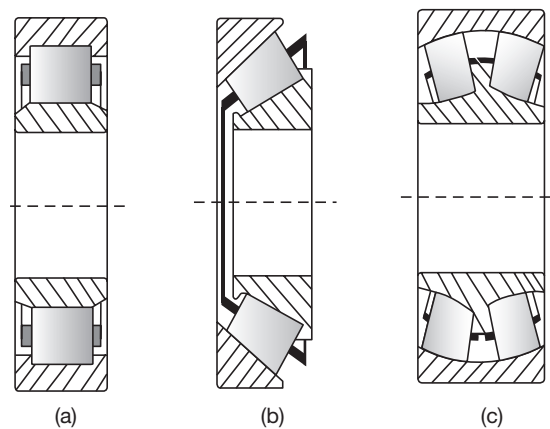
**Thrust Ball Bearings:** In thrust bearings, the contact angle exceeds  $45^\circ$ . The maximum value this angle can assume is  $90^\circ$ . In such case, races are on the sideways as shown in Figure 13.17 (d). Such a bearing cannot take any radial load and is used only for thrust loads. The shafts carrying bevel or worm or helical gears should be mounted with thrust bearings, except the shafts carrying honeycomb (Herringbone) gears or crossed helical gears of left- and right hands placed alternatively along the shafts.

### B. Roller Bearings

Roller bearings have a line contact between the rollers and races against the point contact exhibited by ball bearings. Because of the greater contact area between the rollers and races, the load carrying capacity of straight roller bearings is higher compared with ball bearings of similar size. They are stiffer and have longer fatigue life than comparable ball bearings, and costlier. Roller bearings require almost perfect geometry for the raceways and rollers. A slight misalignment will cause the rollers to skew and get out of line. Straight roller bearings do not take thrust loads. For higher radial load capacity, two or more rows of rollers may be provided. For mounting the ring-spindles (neck bearing), roller bearings are used. The different types of roller bearings are shown in Figure 13.19.

**Cylindrical or Plain Roller Bearings:** They are the simplest types of roller bearings (Figure 13.19 (a)). The length to diameter ratio of rollers is from 1:1 to 3:1. The outside diameter of the roller is often crowned to increase the load carrying capacity by eliminating any edge loading.

**Needle Bearings:** For limited radial space, needle bearings are used. In needle bearing, the ratio between the roller length and roller diameter is very large compared with a plain roller bearing. There are two basic forms of needle roller bearings. In one form, the needles are not separated, and in the other form, a roller cage separates the needles. The bearing that does not



**FIGURE 13.19**

Roller Bearings: (a) Plain; (b) Tapered; and (c) Spherical

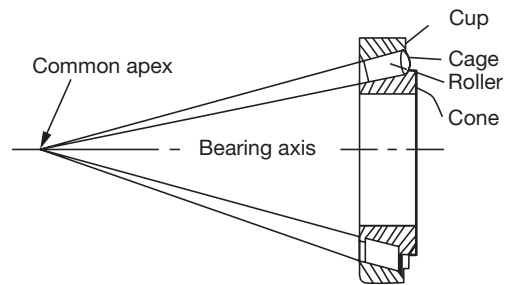
have the needle separator has a full complement of rollers and therefore, can hold higher load compared with the bearings having roller separators. However, the bearing with needle separator is capable of operating at much higher speeds because the separator keeps the needles from one another, preventing a collision. They are often used to support oscillating shafts.

**Tapered Roller Bearings:** In tapered roller bearings, the rollers are frustums of a cone shown in Figure 13.19 (b). They are arranged in such a way that tangents of raceways intersect in a common apex point on the axis of the bearing as shown in Figure 13.20.

Tapered roller bearings are capable of carrying both radial and axial loads, but largely used for applications where axial load component predominates. They are often used in pairs to take the thrust load in both directions.

Since the inner and outer race contact angles are different, there is a force component, which drives the tapered rollers against the guide flange resulting in heating due to friction. Therefore, these bearings are not suitable for high speeds. Tapered roller bearings are ideally suited to withstand repeated shock loads. Multiple-row tapered roller bearings have high radial-load carrying capacity.

**Spherical Roller Bearings:** Spherical roller bearings are called as ‘Self-aligning roller bearings’. Spherical roller bearings as shown in Figure 13.19 (c) consists of two rows of spherical rollers, which run on a common spherical outer race. The inner race can freely adjust itself to the angular misalignment of the shaft in the bearings due to mounting errors or shaft deflection under heavy load. They are especially good for heavy loads. Shafts of the cylinder, doffer, stripper roller and calendar roller are mounted in self-aligning roller bearings, which are grease lubricated.



**FIGURE 13.20**

Tapered Roller Bearing

### 13.13 ► PROPERTIES OF BEARING MATERIALS

The bearing material should have following characteristics from the service point of view.

- ▶ High strength to sustain the bearing load, high compressive, and fatigue strength.
- ▶ High thermal conductivity to dissipate the heat quickly.
- ▶ Low coefficient of friction. Less wear and tear. Low cost. Bearing materials should not readily weld itself to the shaft material.
- ▶ Good corrosion resistance in case the lubricant has the tendency to oxidize the bearing.
- ▶ Good conformability. The bearing should adjust to misalignment or geometric errors, materials with a low modulus of elasticity usually have good conformability.

### 13.14 ► BEARING MATERIALS

The materials used for sliding contact bearings are Cast iron, brass and alloy materials such as bronzes (copper-tin), Babbitt (alloys of tin-copper-lead-antimony), copper-lead alloys and aluminum-tin alloys. Rubber and synthetic composite materials are also used for certain applications (synthetic bearings). The materials used for rolling contact bearings are alloy steel based on Cr-Ni, Mn-Cr, and Cr-Mo. They should have the capability of being hardened to required level. They require high resistance against wear and fatigue and stability up to 125°C.



## RECAP ZONE .....

### Points to Remember

- **Spring** is an elastic body whose function is to distort when loaded and to recover its original shape when the load is removed.
- Springs are used for cushioning, absorbing, or controlling of energy due to shock and vibration, the motion of machine elements, the necessary pressure in a friction device, measure the forces, and store the energy.
- **Helical springs** are made of a wire coiled in the form of a helix and are primarily used to bear compressive or tensile loads.
- The **conical and volute springs** are used in special applications where the spring rate increases in an increase in load.
- **Torsion springs** may be of the helical or spiral type and used to apply torsion.
- A **cam** is a rotating component in a mechanical linkage that drives the mating component, i.e., follower. The transmitted motion may be reciprocating, linear, simple harmonic motion, etc.
- A **bush bearing** or bushing is the most common form of a plain bearing.
- Broadly, there are two types of bearings, one is sliding contact or bush bearing and another is rolling contact bearing.
- The **journal bearings** are used to support the load in the radial direction.
- A **rolling contact bearing** is called as 'anti-friction bearing'. It is an assembly of rolling elements (balls or rollers) placed between the shaft and housing, maintaining radial space between them.

### Important Formulae

1. For Helical Spring: Solid length =  $n \times d$ ; where  $n$  is the number of coils in the spring and  $d$  is the diameter of the spring wire.
2. For Helical Spring: Free length,  $L_f$  = solid length + max. deflection + clearance between adjacent coils.
3. Spring index,  $C = D/d$ ; where 'D' is the mean diameter of the coil and  $d$  is the diameter of the wire.
4. Spring Rate,  $k = F/\delta$ ; where  $F$  is the load applied and  $\delta$  is the deflection.

5. Shear stress in helical spring:

$$\begin{aligned}\tau_{\max} &= \tau_T + \tau_F = \frac{8FD}{\pi d^3} + \frac{4F}{\pi d^2} \\ &= \frac{8FD}{\pi d^3} \left( 1 + \frac{1}{2D} \right) = \frac{8FD}{\pi d^3} \left( 1 + \frac{1}{2C} \right) = K_S \frac{8FD}{\pi d^3};\end{aligned}$$

$$\tau_{\max} = K_w \frac{8FD}{\pi d^3}$$

$$\text{where } K_w \text{ (Wahl correction factor)} = \frac{4C-1}{4C-4} + \frac{0.615}{C}$$

$$6. \quad \delta = \theta \times D/2 = \frac{16F.D^2.n}{G.d^4} \times \frac{D}{2} = \frac{8F.D^3.n}{G.d^4}$$

$$7. \quad \text{Stiffness of the spring, } k = \frac{F}{\delta} = \frac{G.d^4}{8D^3.n} = \frac{G.d}{8C^3.n}$$

8. For series connection, the equivalent spring stiffness is calculated as:

$$\delta = \delta_1 + \delta_2 \quad \text{or,} \quad \frac{F}{k_e} = \frac{F}{k_1} + \frac{F}{k_2} \quad \text{or,} \quad k_e = \frac{k_1 k_2}{k_1 + k_2}$$

9. For parallel connection, the equivalent spring stiffness is calculated as:

$$W = W_1 + W_2 \quad \text{or,} \quad k_e \delta = k_1 \delta + k_2 \delta \quad \text{or,} \quad \delta = \delta_1 + \delta_2$$

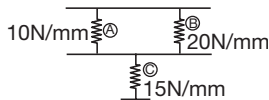
## REVIEW ZONE .....



### Multiple-choice Questions

- The load required to produce a unit deflection in the spring is called:
  - Modulus of rigidity
  - Flexural rigidity
  - Spring stiffness
  - Torsional rigidity
- The most important properties of the spring material is:
  - High elastic limit
  - High deflection
  - Resistance to fatigue and shock
  - All the above
- The purpose of the spring used in brakes and clutch is:
  - To measure the forces
  - To apply the forces
  - To absorb the shocks
  - To absorb the strain energy
- A spring used to absorb shocks and vibrations is:
  - Open coiled helical spring
  - Close coil helical spring
  - Leaf spring
  - Spiral spring
- The laminated springs are given initial curvature to:
  - Have a uniform strength
  - Make it more economical
  - Make plates flat, when subjected to design load
  - None of these
- If a close-coiled helical spring is subjected to load  $W$  and the deflection  $\delta$ , then stiffness of the spring is given by:
  - $W/\delta$
  - $W\delta$
  - $\delta/W$
  - $W\delta^2$

7. When a close-coiled helical spring is subjected to an axial load, it is said to be under:  
 (a) Shear (b) Bending  
 (c) Torsion (d) Crushing
8. When a close-coiled helical spring is cut into two equal parts. The stiffness of the resulting springs will be:  
 (a) Same (b) Double  
 (c) Half (d) One-fourth
9. Three springs are arranged as shown in Figure 13.21, the spring constant will be:



**FIGURE 13.21**

- (a) 10 N/mm (b) 20 N/mm  
 (c) 30 N/mm (d) 40 N/mm
10. A spring of spring constant  $K$  is cut into  $n$  equal lengths. The spring constant of each new part will be:  
 (a)  $K/n$  (b)  $n/K$   
 (c)  $n.K$  (d)  $Kn$
11. A close-coiled helical spring of stiffness 30 N/mm is arranged with another spring of stiffness 60 N/mm. The stiffness of composite unit is:  
 (a) 10 N/mm (b) 20 N/mm  
 (c) 30 N/mm (d) 40 N/mm
12. Two close-coiled helical spring of stiffness  $K_1$  and  $K_2$  are connected in parallel. The combination is equivalent to a single spring of stiffness:  
 (a)  $\sqrt{K_1 K_2}$  (b)  $\frac{K_1 K_2}{2}$   
 (c)  $K_1 + K_2$  (d)  $\frac{K_1 K_2}{K_1 + K_2}$
13. Two close-coiled helical spring of stiffness  $K_1$  and  $K_2$  are connected in series. The combination is equivalent to a single spring of stiffness:  
 (a)  $\sqrt{K_1 K_2}$  (b)  $\frac{K_1 K_2}{2}$   
 (c)  $K_1 + K_2$  (d)  $\frac{K_1 K_2}{K_1 + K_2}$
14. Which motion of follower is best for high speed cams?  
 (a) SHM follower motion  
 (b) Uniform acceleration and retardation of follower motion  
 (c) Cycloidal motion follower  
 (d) All of the above
15. Which of the following statements is false for SHM follower motion?  
 (a) SHM can be used only for moderate speed purpose  
 (b) The acceleration is zero at the beginning and the end of each stroke  
 (c) The jerk is maximum at the mid of each stroke  
 (d) Velocity of follower is maximum at the mid of each stroke
16. Which of the following conditions can be used to minimize undercutting in cam and follower mechanism?  
 (a) By using larger roller diameter  
 (b) By using internal cams  
 (c) By decreasing the size of the cam  
 (d) All of the above
17. What is meant by jump phenomenon in cam and follower system?  
 (a) Follower loses contact with cam surface when cam rotates beyond particular speed due to inertia forces  
 (b) Follower loses contact with cam surface when follower rotates beyond particular speed due to gravitational force  
 (c) Follower loses contact with cam surface when cam rotates beyond particular speed due to gravitational forces  
 (d) None of the above
18. Which of the following are functions of bearings?  
 (a) Ensure free rotation of shaft with minimum friction  
 (b) Holding shaft in a correct position  
 (c) Transmit the force of the shaft to the frame  
 (d) All of the listed
19. A \_\_\_\_\_ bearing supports the load acting along the axis of the shaft.  
 (a) Thrust (b) Radial  
 (c) Longitudinal (d) Transversal
20. Load acting on bearing in its plane of rotation is called as \_\_\_\_\_.  
 (a) Axial load  
 (b) Radial load  
 (c) Thrust load  
 (d) None of the above

## Answers

- |         |         |         |         |         |         |
|---------|---------|---------|---------|---------|---------|
| 1. (c)  | 2. (d)  | 3. (b)  | 4. (c)  | 5. (c)  | 6. (a)  |
| 7. (c)  | 8. (b)  | 9. (a)  | 10. (c) | 11. (b) | 12. (c) |
| 13. (d) | 14. (c) | 15. (b) | 16. (b) | 17. (a) | 18. (d) |
| 19. (a) | 20. (b) |         |         |         |         |

## Theory Questions

1. What are the applications of springs?
2. Explain the classification of springs?
3. Discuss the different types of spring materials.
4. Derive an expression for shear stress and deflection in a helical spring subjected to an axial force.
5. Derive an expression for the equivalent spring constant when two similar springs are connected: (a) in parallel, (b) in series.
6. What do you mean by cam and cam followers? Give some example of their industrial applications?
7. Discuss the classification of the cam and followers.
8. What are the different types of bushes? Discuss its applications in engineering.
9. What is the difference between sliding contact bearings and rolling contact bearings?
10. Explain the different types of ball bearings used in the industry.
11. Discuss the use of roller bearings.
12. What are the different types of engineering materials used for manufacturing of bearings?
13. What are the properties required for the bearing materials?
14. Explain the thrust loading and radial loading in the bearing.

## Numerical Problems

1. A close coiled helical spring has to absorb 60 Nm of energy when compressed 5 cm. The coil diameter is six times the wire diameter. If there are 18 coils, estimate the diameters of coil and wire and the maximum shear stress.  $G = 85,000 \text{ N/mm}^2$ .
2. A close-coil helical spring is to have a stiffness of 800 N/m in compression, with a maximum load of 40 N and a maximum shearing stress of 120 N/mm<sup>2</sup>. The solid length of the spring is 48 mm. Find the wire diameter, mean coil radius, and the number of coils.  $G = 50,000 \text{ N/mm}^2$ . (Assume shear stress is produced only due to the torque produced in the wire due to axial loading).
3. A composite spring has two close coiled helical springs connected in series; each spring has twelve coils at a mean diameter of 24 mm. Find the wire diameter in one if the other is 3 mm and the stiffness of the composite spring is 640 N/m. Estimate the greatest load can be carried out by the composite spring, and the corresponding extension, for a maximum shearing stress of 160 N/mm<sup>2</sup>.  $G = 75,000 \text{ N/mm}^2$ .

## Learning Objectives

*By the end of this chapter, the student will be able:*

- To understand the function of a flywheel as an energy reservoir
- To calculate the energy fluctuation and variation in speed of the flywheel
- To demonstrate the working of different types of governors
- To describe the governing of an internal combustion engine
- To differentiate the working of flywheel and governor

## FLYWHEEL

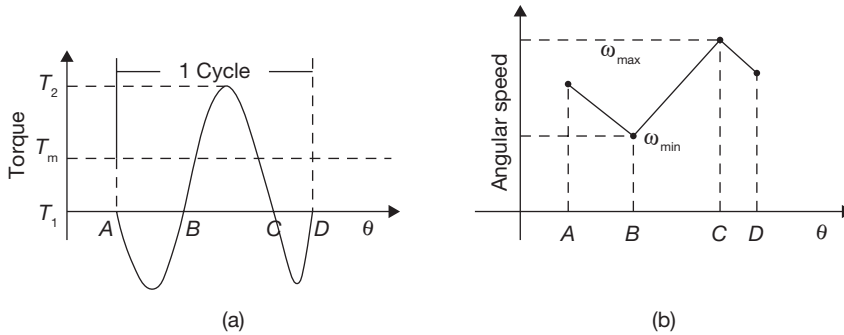
### 14.1 ► INTRODUCTION

Flywheel is an internal energy-storage device. It absorbs mechanical energy and during the period when the supply of energy is more than the requirement and releases it during the period when the requirement of energy is more than the supply. The main function of a fly wheel is to smoothen out variations in the speed of a shaft caused by torque fluctuations. If the source of the driving torque or load torque is fluctuating in nature, then a flywheel is used. Many machines have load patterns that cause the torque time function to vary over the cycle as shown in Figure 14.1. Internal combustion engines with one or two cylinders are a typical example. Piston compressors, punch presses, rock crushers, etc. are the other systems that have a flywheel.

The change in the shaft speed during a cycle is called the speed fluctuation and is equal to  $\omega_{\max} - \omega_{\min}$ . We can normalize this to a dimensionless ratio by dividing it by the average or nominal shaft speed.

$$K_f = \frac{\omega_{\max} - \omega_{\min}}{\omega}$$





**FIGURE 14.1**

(a)  $T - q$  Diagram and (b)  $\omega - q$  Diagram

Where  $K_f$  is the coefficient of speed fluctuation,  $\omega_{\max}$  and  $\omega_{\min}$  are maximum and minimum angular velocities respectively, and  $\omega$  is mean angular velocity.

### 14.2 ► MASS MOMENT OF INERTIA OF FLYWHEEL

The function of the flywheel is to store excess energy during the power stroke and it supplies energy during another stroke. Thereby, it reduces fluctuation in the speed within the cycle. Let  $\omega_1$  be the maximum angular speed and  $\omega_2$  be the minimum angular speed.

Let  $I$  be the mass moment of inertia of the flywheel neglecting mass moment of inertia of the other rotating parts which is negligible in comparison to mass moment of inertia of the flywheel.

Maximum kinetic energy of flywheel,  $(K.E.)_{\max} = \frac{1}{2} I \omega_1^2$

Minimum kinetic energy of flywheel,  $(K.E.)_{\min} = \frac{1}{2} I \omega_2^2$

Change in K.E., DK.E. = Fluctuation in energy,  $\Delta E = \frac{1}{2} I (\omega_1^2 - \omega_2^2)$   
 $= \frac{1}{2} I (\omega_1 - \omega_2)(\omega_1 + \omega_2)$   
 $= \frac{1}{2} I (\omega_1 - \omega_2) \times 2\omega$

where  $\omega$  is average speed given by,  $\frac{\omega_1 + \omega_2}{2}$ .

$$\Delta E = -I \frac{(\omega_1 - \omega_2)}{2} \times 2\omega^2 = I \times K \times \omega^2;$$

Energy fluctuation can be determined from the turning moment diagram. For selected value of  $K_f$  and given value of speed  $\omega$ ,  $I$  can be determined.

$$\Delta E = \frac{1}{2} I \frac{(\omega_1 - \omega_2)}{\omega} \times 2\omega^2 = \frac{1}{2} \times M k^2 \times (\omega_1^2 - \omega_2^2) = \frac{1}{2} \times M \times (k^2 \omega_1^2 - k^2 \omega_2^2) = \frac{1}{2} \times M \times (V_1^2 - V_2^2)$$

where  $M$  is mass of flywheel and  $k$  is radius of gyration.

It can be observed that

- The flywheel will be heavy and of large size, if  $\Delta E$  is large. The value of  $K_f$  is limited by the practical considerations. Therefore, the single cylinder 4-stroke engine shall require larger flywheel as compared to the multi-cylinder engine.
- For slow speed engine also the flywheel required is larger in size because of the high value of  $I$  required.
- For high-speed engines, the size of flywheel shall be considerably smaller because of the lower value of  $I$  required.
- If the system can tolerate considerably higher speed fluctuations, the size of the flywheel will also be smaller for the same value of  $\Delta E$ .

### EXAMPLE 14.1

The mass of a flywheel of an engine is 6 tons and the radius of gyration is 2 meters. It is found from the turning moment diagram that the fluctuation of energy is 50 kNm. If the mean speed of the engine is 120 rpm, find the maximum and minimum speeds.

### SOLUTION

Let  $N_1$  and  $N_2$  be the maximum and minimum speed, respectively.

$$\Delta E = \frac{1}{2} I (\omega_1^2 - \omega_2^2) = \frac{1}{2} I (\omega_1 - \omega_2)(\omega_1 + \omega_2) = \frac{1}{2} I (\omega_1 - \omega_2) \times 2\omega$$

$$\begin{aligned} \Delta E &= 50,000 \text{ Nm} = \frac{\pi^2}{900} \times m \cdot k^2 \times N (N_1 - N_2) \\ &= \frac{\pi^2}{900} \times 6,000 \text{ kg} \times (2 \text{ m})^2 \times 120 \text{ rpm} (N_1 - N_2) \\ &= 31550.72 (N_1 - N_2) \end{aligned}$$

$$N_1 - N_2 = 1.584 \text{ rpm}$$

$$N = \frac{N_1 + N_2}{2} = 120 \text{ rpm} \Rightarrow N_1 + N_2 = 240 \text{ rpm}$$

or  $N_1 = 120.79 \text{ rpm}$  and  $N_2 = 119.20 \text{ rpm}$

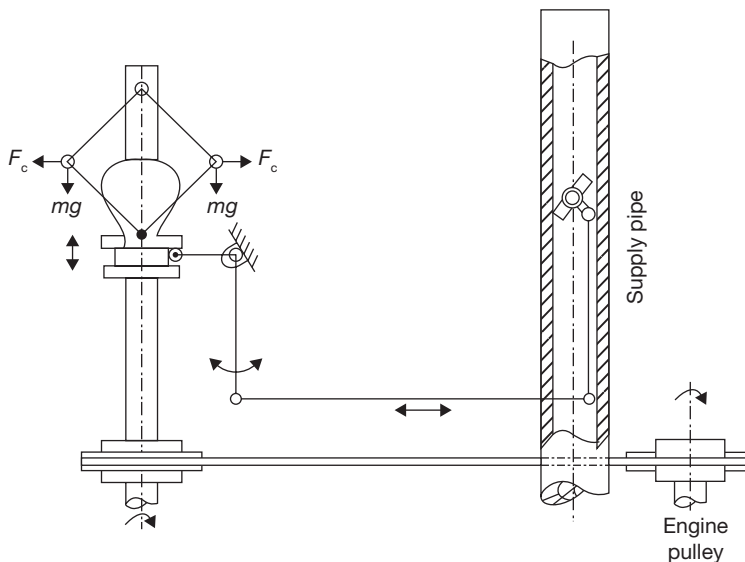
## GOVERNORS

## 14.3 ► INTRODUCTION

Governor takes care of the change of speed due to load variation over periods of the engine's running and tends to keep it as close to the mean speed as possible, whereas the flywheel is responsible only for keeping the speed fluctuations, during each cycle within certain permissible limits of the mean speed. As such, one cannot be replaced by the other.

The function of the governor is to adjust the supply of fuel according to the load requirements so as to keep the speeds at various loads, as close to the mean speed as possible, over a long range of working of the engines.

Its function is distinct from that of a flywheel, which acts as a reservoir and keeps the speed within certain limits of the mean speed during the thermodynamic cycles. The function of a flywheel is continuous from cycle to cycle, but that of governor it is more or less intermittent, i.e., it reacts only whenever there is a variation of load. The speed control mechanism by the governor is shown in Figure 14.2.



**FIGURE 14.2**

Speed Control by Governor

Figure 14.2 shows a schematic diagram of a governor along with linkages, which regulate the supply of fuel. The governor shaft is coupled with engine shaft. If the load on the engine increases the engine speed tends to reduce, as a result of which governor balls move inwards. The inward movement of the ball causes the sleeve to move downwards and hence increase the opening of the valve through the linkage. Thus, fuel supply increases at higher load.

On the other hand, a decrease in the load increases engine speed. As a result of which the governor balls try to fly outwards. This causes an upward movement of the sleeve and it reduces the supply of fuel. Thus, the energy input is adjusted to the new load on the engine. Thus the governor senses the change in speed and then adjusts the supply of fuel.

## 14.4 ► TERMINOLOGY USED IN GOVERNORS

There are some general terms used in governors that describe qualities of the governor. These terms are as:

**Height of Governor:** It is the vertical distance between the center of the governor balls and the point of intersection between the upper arms on the axis of the spindle. It is generally denoted by  $h$ .

**Equilibrium Speed:** The speed at which the governor balls, the arms, etc. are in complete equilibrium and the sleeve does not tend to move upward or downward is called the equilibrium speed.

**Sleeve Lift:** The vertical distance the sleeve travels due to change in the equilibrium speed is called the sleeve lift. The vertical downward travel may be termed as a negative lift.

**Effort and Power of a Governor:** A governor running at a constant speed is in equilibrium and the resultant force acting on the sleeve is zero. If the speed of the governor increases there is a force on the sleeve which tends to lift it. This force will gradually go on decreasing till the governor starts rotating in equilibrium at the new position of rotation. The mean force acting on the sleeve for a given change of speed or lift of the sleeve is known as the governor effort.

**Controlling Force:** The force acting radially inward upon the rotating balls to counteract its centrifugal force is called the controlling force. It is provided by weight on the sleeve or compressed spring.

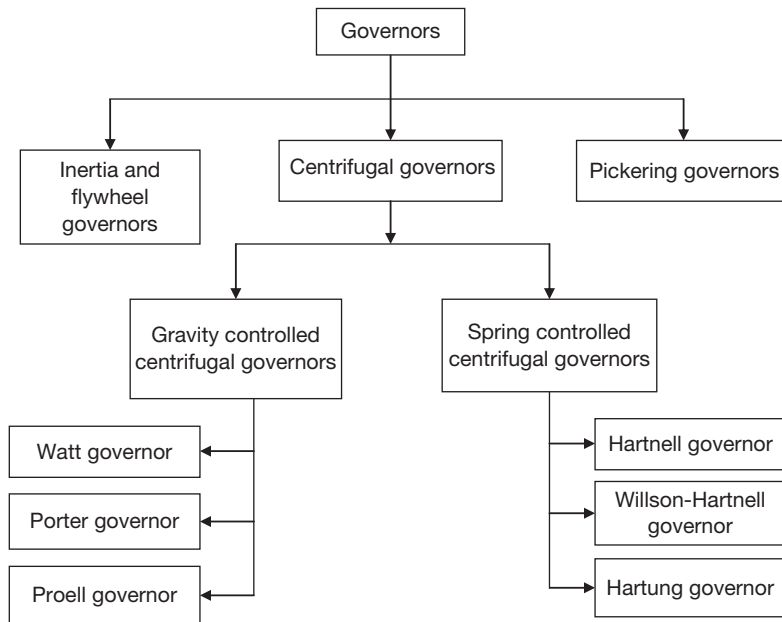
**Isochronism:** This is an extreme case of sensitiveness. When the equilibrium speed is constant for all radii of rotation of the balls within the working range, the governor is said to be in isochronism. This means that the difference between the maximum and minimum equilibrium speeds is zero and the sensitiveness shall be infinite.

**Hunting:** The phenomenon of continuous fluctuation of the engine speed above and below the mean speed is termed as hunting. This occurs in over-sensitive or isochronous governors.

**Sensitiveness:** A governor is said to be sensitive if its change of speeds from no load to full load may be as small a fraction of the mean equilibrium speed as possible and the corresponding sleeve lift may be as large as possible.

## 14.5 ► CLASSIFICATION OF GOVERNORS

Classification of governors is shown in Figure 14.3.



**FIGURE 14.3**

Classification of Governors

**Inertia and Flywheel Governors:** In these governors, the inertia forces caused by the angular acceleration of the engine shaft or flywheel by a change in speed are utilized for the movement of the balls. The movement of the balls is due to the rate of change of speed instead of a change in speed itself as in the case of centrifugal governors. Thus, these governors are more sensitive than centrifugal governors.

**Centrifugal Governors:** In these governors, the change in centrifugal forces of the rotating masses due to change in the speed of the engine is utilized for movement of the governor sleeve.

**Pickering Governors:** This type of governor is used for driving a gramophone. As compared to the centrifugal governors, the sleeve movement is very small. It controls the speed by dissipating the excess kinetic energy. It is very simple in construction and can be used for a small machine.

## 14.6 ► GRAVITY CONTROLLED CENTRIFUGAL GOVERNORS

### 14.6.1 Watt Governor

This governor was initially used by James Watt in a steam engine. The spindle is driven by the output shaft of the prime mover. The balls are mounted at the junction of the two arms.

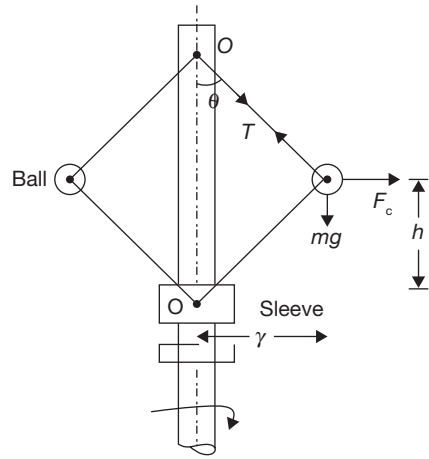
The upper arms are connected to the spindle and lower arms are connected to the sleeve as shown in Figure 14.4.

Masses of the sleeves and upper and lower arms are considered as negligible for simplicity of analysis. We can ignore the frictional forces also. The ball is subjected to the three forces: centrifugal force ( $F_c$ ), weight ( $mg$ ), and tension by upper arm ( $T$ ). Taking moment about point  $O$  (Intersection of arm and spindle axis), we get

$$F_c \times h - mg \times r = 0$$

$$\text{or, } m\omega^2 r h - mg \times r = 0$$

$$\text{or, } h = \frac{g}{\omega^2} = \frac{9.81 \text{ m/sec}^2 \times 60 \text{ sec} \times 60 \text{ sec}}{4 \times \pi^2 \times N^2} = \frac{895}{N^2}$$



**FIGURE 14.4**

Watt Governor

### EXAMPLE 14.2

Calculate the vertical height of a Watt governor rotating at the speed of 80 rpm. Also, calculate the change in the height when the speed increases to 100 rpm.

### SOLUTION

$$N_1 = 80 \text{ rpm}, N_2 = 100 \text{ rpm}$$

$$h_1 = \frac{895}{N_1^2} = \frac{895}{80^2} = 0.1398 \text{ m}$$

$$h_2 = \frac{895}{N_2^2} = \frac{895}{100^2} = 0.0895 \text{ m}$$

$$\text{Change in height} = h_1 - h_2 = 0.1398 \text{ m} - 0.0895 \text{ m} = 0.0503 \text{ m}$$

## 14.6.2 Porter Governor

A schematic diagram of the porter governor is shown in Figure 14.5. There are two sets of arms. The top arms  $OA$  and  $OB$  connect balls to the hinge  $O$ . The hinge may be on the spindle or slightly away. The lower arms support dead weight and connect balls also. All of them rotate with the spindle. We can consider one-half of the governor for equilibrium.

Let  $w$  be the weight of the ball,

$W$  be the central load,

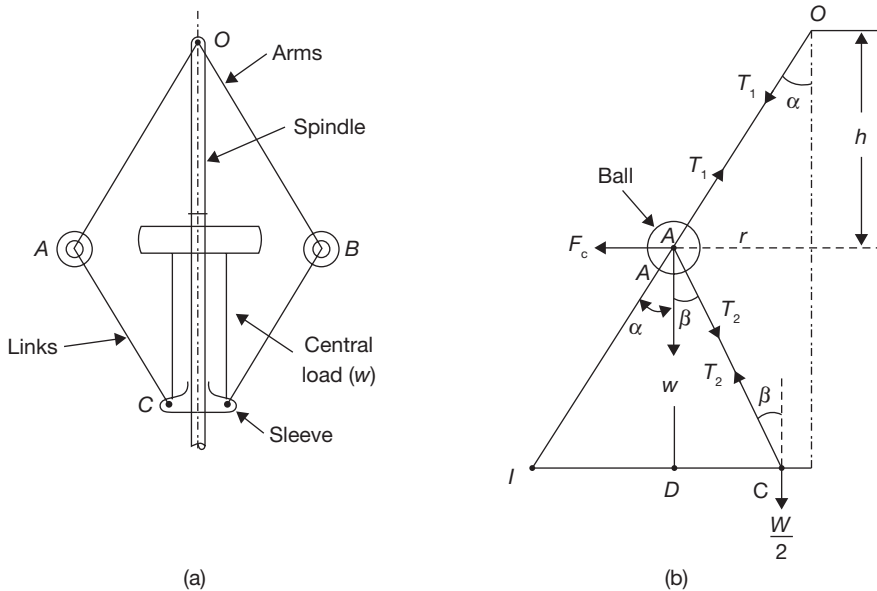
$T_1$  and  $T_2$  be tension in upper and lower arms, respectively,

$F_c$  be the centrifugal force,

$r$  be the radius of rotation of the ball from the axis, and

$I$  is the instantaneous center of the lower arm.

Taking moment of all forces acting on the ball about  $I$  and neglecting friction at the sleeve, we get



**FIGURE 14.5**

Force Analysis in Porter Governor

Taking moment of all forces acting on the ball  $A$  or ball  $B$  about  $I$  and neglecting friction on the sleeve, we get

$$F_c \times AD - w \times ID - \frac{W}{2} \times IC = 0$$

$$F_c = w \times \frac{ID}{AD} + \frac{w}{2} \times \frac{IC}{AD} = w \times \frac{ID}{AD} + \frac{W}{2} \times \frac{(ID + CD)}{AD}$$

$$= w \tan \alpha + \frac{W}{2} (\tan \alpha + \tan \beta)$$

Also,

$$F_c = \frac{w}{g} \omega^2 r$$

$$F_C = \frac{w}{g} \omega^2 r = w \tan \alpha + \frac{W}{2} (\tan \alpha + \tan \beta)$$

Thus,

$$\frac{w}{g} \omega^2 r = w \tan \alpha \left[ 1 + \frac{W}{2w} \left( 1 + \frac{\tan \beta}{\tan \alpha} \right) \right]$$

$$\omega^2 = \frac{g}{r} \times \frac{r}{h} \left[ 1 + \frac{W}{2w} (1 + K) \right]$$

where

$$\tan \alpha = \frac{r}{h} \quad \text{and} \quad K = \frac{\tan \beta}{\tan \alpha}$$

$$\omega^2 = \frac{g}{h} \left[ 1 + \frac{W}{2w} (1 + K) \right]$$

If friction acting on the sleeve be  $f$ , the force at the sleeve can be replaced by  $W + f$  for rising and  $(W - f)$  for falling speed as friction opposes the motion of sleeve. Therefore, if the friction at the sleeve is to be considered,  $W$  should be replaced by  $(W \pm f)$ . The expression for  $\omega_2$  can be written as

$$\omega^2 = \frac{g}{h} \left\{ 1 + \frac{(W \pm f)}{2w} (1 + K) \right\}$$

### EXAMPLE 14.3

A porter governor has an equal arm's length of 240 mm long and pivoted at the axis of rotation. Each ball has a mass of 5 kg and the mass of central load on the sleeve is 20 kg. When the governor begins to lift, the radius of rotation of the ball is 120 mm and 150 mm when the governor is at maximum speed. Find the minimum and maximum speeds and range of speed of the governor.

### SOLUTION

Let  $N_1$  = Minimum speed

$$h_1 = \sqrt{(0.24m)^2 - (0.12m)^2} = 0.207m$$

$$\omega_1^2 = \frac{g}{h} \left[ 1 + \frac{W}{2w} (1 + K) \right]$$

Here, arms length is equal, therefore,  $\tan \alpha = \tan \beta$  and  $k = 1$

$$\omega_1^2 = \frac{g}{h} \left\{ 1 + \frac{W}{w} \right\} \Rightarrow N_1^2 = \frac{895}{h_1} \left\{ 1 + \frac{M}{m} \right\} = \frac{895}{0.207m} \left\{ 1 + \frac{20kg}{5kg} \right\}$$

$$4\pi^2 N_1^2 = 853043.47; N_1 = 147.03 \text{ rpm}$$



At maximum speed

$$h_2 = \sqrt{(0.24m)^2 - (0.15m)^2} = 0.1873m$$

$$\omega_2^2 = \frac{g}{h} \left\{ 1 + \frac{W}{w} \right\} \Rightarrow N_2^2 = \frac{895}{h_1} \left\{ 1 + \frac{M}{m} \right\} = \frac{895}{0.1873m} \left\{ 1 + \frac{20kg}{5kg} \right\}$$

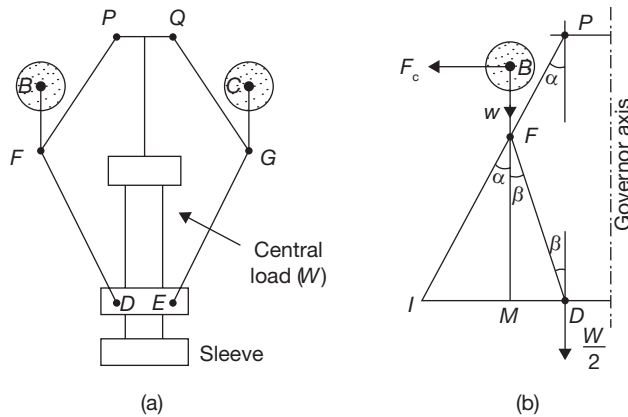
$$4\pi^2 N_2^2 = 188553.12; N_2 = 154.57 \text{ rpm}$$

$$\text{Range of speed} = N_2 - N_1 = 154.57 \text{ rpm} - 147.03 \text{ rpm} = 7.54 \text{ rpm}$$

### 14.6.3 Proell Governor

The Proell governor has the balls at B and C to the extension of the links DF and EG, as shown in Figure 14.6 (a). The arm PF and GQ are pivoted at P and Q respectively. Consider the free body diagram of half of the governor as shown in Figure 14.6(b). The instantaneous center (I) lies on the intersection of the line PA produced and the line from D drawn a perpendicular to the axis.

Taking moment about instantaneous center (I), we get



**FIGURE 14.6**

Force Analysis in Proell Governor

$$F_C \times BM = w \times IM + \frac{W}{2} \times ID$$

$$F_C = w \times \frac{IM}{BM} + \frac{W}{2} \times \left( \frac{IM + MD}{BM} \right)$$

Multiplying and dividing by  $FM$

$$\begin{aligned} F_C &= \frac{FM}{BM} \left[ w \times \frac{IM}{FM} + \frac{W}{2} \times \left( \frac{IM + MD}{FM} \right) \right] \\ &= \frac{FM}{BM} \left[ w \times \tan \alpha + \frac{W}{2} \times (\tan \alpha + \tan \beta) \right] \\ &= \frac{FM}{BM} \times \tan \alpha \left[ w + \frac{W}{2} \times \left( 1 + \frac{\tan \beta}{\tan \alpha} \right) \right] \end{aligned}$$

Putting

$$\begin{aligned} F_C &= \frac{w}{g} \omega^2 r; \quad \tan \alpha = \frac{r}{h}; \quad \text{and} \quad \frac{\tan \beta}{\tan \alpha} = K \\ \frac{w}{g} \omega^2 r &= \frac{FM}{BM} \times \frac{r}{h} \left[ w + \frac{W}{2} \times (1 + K) \right] \\ \omega^2 &= \frac{FM}{BM} \times \frac{g}{h} \left[ 1 + \frac{W}{2w} \times (1 + K) \right] \end{aligned}$$

#### EXAMPLE 14.4

A Proell governor has an equal arm's length of 400 mm. The upper and lower ends of the arms are pivoted on the axis of the governor. The extension arms of the lower links are each 60 mm long and parallel to the axis when the radii of rotation of the balls are 180 mm and 240 mm. The mass of each ball is 10 kg and mass of the central load is 80 kg. Determine the range of the speed of the governor.

#### SOLUTION

Let  $N_1$  = minimum speed at radius  $r_1 = 180 \text{ mm}$

$N_2$  = minimum speed at radius  $r_2 = 240 \text{ mm}$

Now at minimum speed,

$$h_1 = \sqrt{(0.4\text{m})^2 - (0.18\text{m})^2} = 0.357 \text{ m}$$

$$FM = h_1 = 357 \text{ mm}$$

$$BM = BF + FM = 60 \text{ mm} + 357 \text{ mm} = 417 \text{ mm} = 0.417 \text{ m}$$

$$\omega_1^2 = \frac{FM}{BM} \times \frac{g}{h_1} \left[ 1 + \frac{W}{2w} \times (1 + K) \right]; \quad \text{here } K = 1$$

$$N_1^2 = \frac{FM}{BM} \times \frac{895}{h_1} \left( 1 + \frac{W}{w} \right) = \frac{0.357\text{m}}{0.417\text{m}} \times \frac{895}{0.357\text{m}} \left( 1 + \frac{80\text{kg}}{10\text{kg}} \right) = 19,316.54$$

$$N_1 = 138.98 \text{ rpm}$$

At maximum speed,

$$h_2 = \sqrt{(0.4m)^2 - (0.24m)^2} = 0.320m$$

$$FM = h_2 = 320 \text{ mm}$$

$$BM = BF + FM = 60 \text{ mm} + 320 \text{ mm} = 380 \text{ mm} = 0.38 \text{ m}$$

$$\omega_2^2 = \frac{FM}{BM} \times \frac{g}{h_2} \left[ 1 + \frac{W}{2w} \times (1+K) \right]; \text{ here } K = 1$$

$$N_2^2 = \frac{FM}{BM} \times \frac{895}{h_2} \left( 1 + \frac{W}{w} \right) = \frac{0.320m}{0.380m} \times \frac{895}{0.320m} \left( 1 + \frac{80kg}{10kg} \right) = 25,171.87$$

$$N_2 = 158.65 \text{ rpm}$$

$$\text{Range of speed} = N_2 - N_1 = 158.65 \text{ rpm} - 138.98 \text{ rpm} = 19.67 \text{ rpm}$$

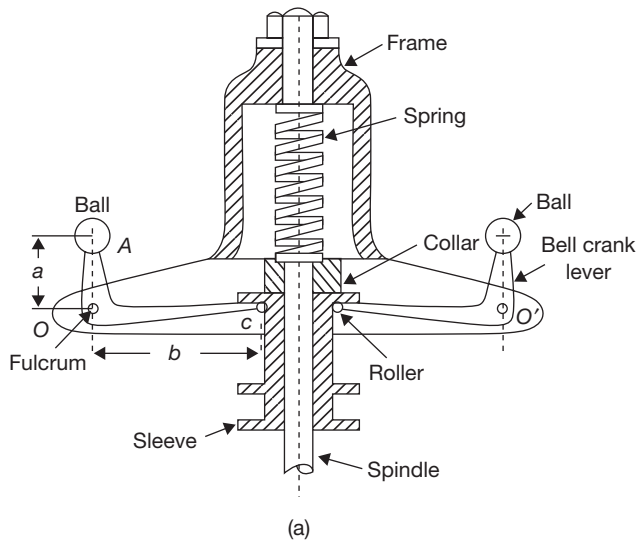
## 14.7 ► SPRING CONTROLLED CENTRIFUGAL GOVERNOR

### 14.7.1 Hartnell Governor

The Hartnell governor is shown in Figure 14.7(a). The two bell crank levers are used which can rotate about fulcrums O and O'. One end of both bell crank lever carries a ball and a roller at the other end of the arm. The rollers make contact with the sleeve. A helical spring is mounted on the spindle between frame and sleeve. With the rotation of the spindle, all these parts rotate.

With the increase in speed, the radius of rotation of the balls increases and the rollers lift the sleeve against the spring force. With the decrease in speed, the sleeve moves downwards. The movement of the sleeve is transferred to the throttle of the engine through linkages.

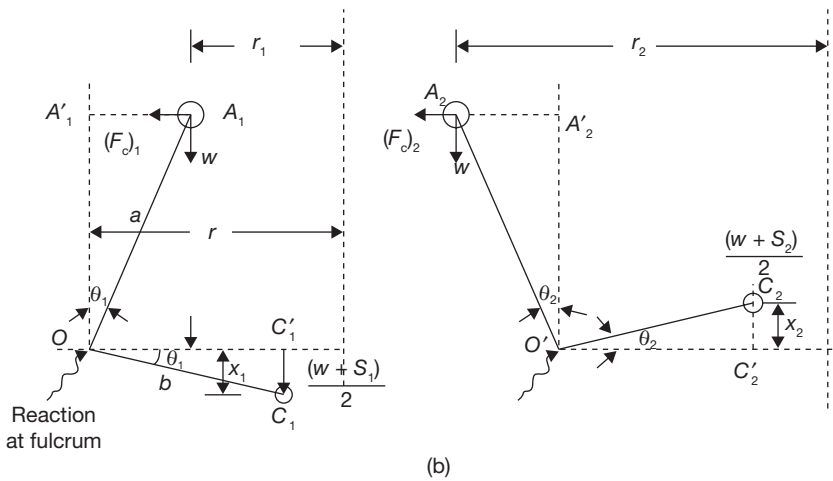
- Let
- $r_1$  = Minimum radius of rotation of ball center from spindle axis, in m,
  - $r_2$  = Maximum radius of rotation of ball center from spindle axis, in m,
  - $S_1$  = Spring force exerted on sleeve at minimum radius, in N,
  - $S_2$  = Spring force exerted on sleeve at maximum radius, in N,
  - $m$  = Mass of each ball, in kg,
  - $M$  = Mass of sleeve, in kg,
  - $N_1$  = Minimum speed of governor at minimum radius, in rpm,
  - $N_2$  = Maximum speed of governor at maximum radius, in rpm,
  - $\omega_1$  and  $\omega_2$  = Corresponding minimum and maximum angular velocities, in r/s,
  - $(F_C)_1$  = Centrifugal force corresponding to minimum speed
  - $(F_C)_2$  = Centrifugal force corresponding to maximum speed
  - $s$  = Stiffness of spring or the force required to compress the spring by one m,
  - $r$  = Distance of fulcrum O from the governor axis or radius of rotation,



**FIGURE 14.7**

(a): Hartnell Governor

$a$  = Length of ball arm of bell-crank lever, i.e., distance OA, and  
 $b$  = Length of sleeve arm of bell-crank lever, i.e., distance OC.



**FIGURE 14.7**

(b): Force Analysis of Hartnell Governor

Considering the position of the ball at radius ' $r_2$ ' as shown in Figure 14.7 (b) and taking the moments of all the forces about O'.

$$(F_C)_2 a \cos \theta_2 + w a \sin \theta_2 = \frac{(W + S_2)}{2} b \cos \theta_2$$

$$(F_C)_2 = \frac{(W + S_2)}{2} \times \frac{b}{a} - w \tan \theta_2$$

If  $\theta_1$  and  $\theta_2$  are small. Weight  $w$  is small in comparison to  $W$  and spring force  $S$ ,  $w \tan \theta_1$  and  $w \tan \theta_2$  can be neglected.

$$(F_C)_1 = \frac{(W + S_1)}{2} \times \frac{b}{a}$$

$$(F_C)_2 = \frac{(W + S_2)}{2} \times \frac{b}{a}$$

$$\text{Total lift} = x_1 + x_2 = b\theta_1 + b\theta_2 = b \left( \frac{r - r_1}{a} + \frac{r_2 - r}{a} \right) = \frac{b}{a} (r_2 - r_1)$$

$$S_2 - S_1 = \text{Total lift} \times s = \frac{b}{a} (r_2 - r_1) s$$

$$(F_C)_2 - (F_C)_1 = \frac{b}{a} (S_2 - S_1) = \left( \frac{b}{a} \right)^2 \left( \frac{r_2 - r_1}{2} \right) s$$

### EXAMPLE 14.5

A Hartnell governor having a central sleeve spring and two right-angled ball crank levers moves between 280 rpm and 320 rpm for a sleeve lift of 15 mm. The sleeve arms and the ball arms are 100 mm and 120 mm respectively. The levers are pivoted at 120 mm from the governor axis and mass of each ball is 4 kg. The ball arms are parallel to the governor axis at the lowest equilibrium speed. Determine load on spring at lowest and highest speeds and stiffness of the spring.

### SOLUTION

Let

$S_1$  = Load on spring at lowest speed

$S_2$  = Load on spring at highest speed

Since the ball arms are parallel to governor axis at the lowest speed, therefore,  
 $r = r_1 = 120$  mm

$$F_{c1} = m\omega_1^2 r_1 = 4 \left( 2 \times \pi \times \frac{280 \text{ rpm}}{60 \text{ sec}} \right)^2 \times 0.120 \text{ m} = 412.26 \text{ N}$$

Let  $r_2$  is radius of rotation at  $N_2 = 320$  rpm.

$$h = (r_2 - r_1) \frac{b}{a} \Rightarrow r_2 = r_1 + h \frac{a}{b} = 0.12m + 0.015m \left( \frac{0.120m}{0.100m} \right) = 0.138m$$

$$F_{c2} = m\omega_2^2 r_2 = 4 \left( 2 \times \pi \times \frac{320rpm}{60sec} \right)^2 \times 0.138m = 619.23N$$

Now,  $M \cdot g + S_1 = 2F_{c1} \times \frac{a}{b} = 2 \times 412.26N \times \frac{0.120m}{0.100m} = 989.42N$

$$S_1 = 989.42N \text{ (Neglecting the effect of } Mg)$$

Similarly,  $M \cdot g + S_2 = 2F_{c2} \times \frac{a}{b} = 2 \times 619.23N \times \frac{0.120m}{0.100m} = 1,486.15N$

$$S_2 = 1486.15N \text{ (Neglecting the effect of } Mg)$$

Stiffness of spring,  $S = \frac{S_2 - S_1}{h} = \frac{1,486.15N - 989.42N}{0.015m} = 33.115N/mm$

### 14.7.2 Willson–Hartnell Governor

In this governor, balls are connected by a spring (in two parts) and one more spring is used in sleeve mechanism to adjust the radius of rotation of the balls as shown in Figure 14.8.

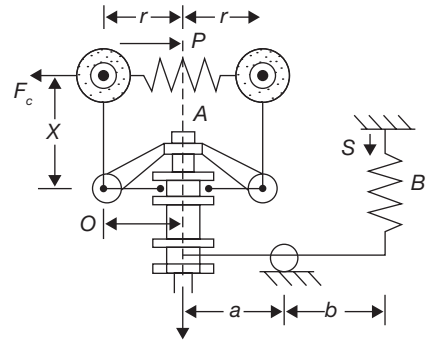
- Let  $P$  = Tension in the main spring A,  
 $S$  = Tension in spring B,  
 $w$  = weight of each ball,  
 $W$  = Weight of sleeve,  
 $s_a$  = Stiffness of each ball spring A,  
 $s_b$  = Stiffness in auxiliary spring B,  
 $F_C$  = Centrifugal force on each ball, and  
 $r$  = radius of rotation of balls.

Taking moment about  $O$  neglecting weight of ball, we get

$$(F_C - P) \times x = \frac{W + S \frac{b}{a}}{2} \times y$$

Using 1 and 2 suffix for minimum and maximum equilibrium speed

$$(F_{C_1} - P_1) \times x = \frac{W + S_1 \frac{b}{a}}{2} \times y \quad (a)$$



**FIGURE 14.8**

Willson-Hartnell Governor

$$(F_{C_2} - P_2) \times x = \frac{W + S_2 \frac{b}{a}}{2} \times y \quad (b)$$

On subtraction, we get

$$\left[ (F_{C_2} - F_{C_1}) - (P_2 - P_1) \right] = \frac{(S_2 - S_1)}{2} \times \frac{b}{a} \times \frac{y}{x} \quad (c)$$

When the radius of rotation increases from  $r_1$  to  $r_2$ , the spring A extends by  $2(r_2 - r_1)$  and spring B extends by  $(r_2 - r_1) \times \frac{b}{a} \times \frac{y}{x}$ .

$$P_2 - P_1 = 2S_a \times 2(r_2 - r_1)$$

$$S_2 - S_1 = S_b (r_2 - r_1) \times \frac{b}{a} \times \frac{y}{x}$$

Substituting the value of  $P_2 - P_1$  and  $S_2 - S_1$  in Eq. (14.3)

$$\left[ (F_{C_2} - F_{C_1}) - 4S_a (r_2 - r_1) \right] = \frac{S_b (r_2 - r_1) \times \frac{b}{a} \times \frac{y}{x}}{2} \times \frac{b}{a} \times \frac{y}{x}$$

$$4S_a + \frac{S_b}{2} \times \left( \frac{b}{a} \times \frac{y}{x} \right)^2 = \frac{F_{C_2} - F_{C_1}}{(r_2 - r_1)}$$

### EXAMPLE 14.6

A Wilson-Hartnell governor consists of balls of mass of 2 kg each, minimum and maximum radius of rotation 150 mm and 180 mm respectively, minimum and maximum speed 220 rpm and 240 rpm respectively, length of ball arm of each bell crank lever 150 mm, length of the sleeve arm of each bell crank lever 100 mm, and combined stiffness of two ball springs 0.2 kN/m. Find the equivalent stiffness of the auxiliary spring referred to the sleeve.

### SOLUTION

Let  $S$  be the equivalent stiffness of the auxiliary spring referred to the sleeve,  $S = S_b \left( \frac{b}{a} \right)^2$

We know the centrifugal force at the minimum speed,

$$F_{C_1} = m(\omega_1^2)r_1 = 2\text{kg} \left( 2 \times \pi \times \frac{220\text{rpm}}{60\text{sec}} \right)^2 \times 0.15\text{m} = 159.06\text{N}$$

$$F_{C_2} = m(\omega_2^2)r_2 = 2\text{kg} \left( 2 \times \pi \times \frac{240\text{rpm}}{60\text{sec}} \right)^2 \times 0.18\text{m} = 227.16\text{N}$$

Now, 
$$4S_a + \frac{S_b}{2} \left( \frac{b}{a} \times \frac{y}{x} \right)^2 = \frac{F_{C_2} - F_{C_1}}{(r_2 - r_1)}$$

$$4 \times 200 \text{ N/m} + \frac{S_b}{2} \left( \frac{b}{a} \times \frac{0.1}{0.15} \right)^2 = \frac{227.16 \text{ kg} - 159.06 \text{ kg}}{(0.180 \text{ m} - 0.150 \text{ m})} = 2,270$$

$$800 \text{ N/m} + 0.22 S_b \left( \frac{b}{a} \right)^2 = 2,270 \quad \text{or,} \quad S_b \left( \frac{b}{a} \right)^2 = \frac{2,270 - 800}{0.22} = 6,681.18 \text{ N/m.}$$

### 14.7.3 Hartung Governor

The Hartung governor is shown in Figure 14.9. In this governor, the vertical arms of the bell crank levers are fitted with spring balls which compress against the frame of the governor when the rollers at the end of horizontal arms press against the sleeve.

Let,  $S$  = spring force,

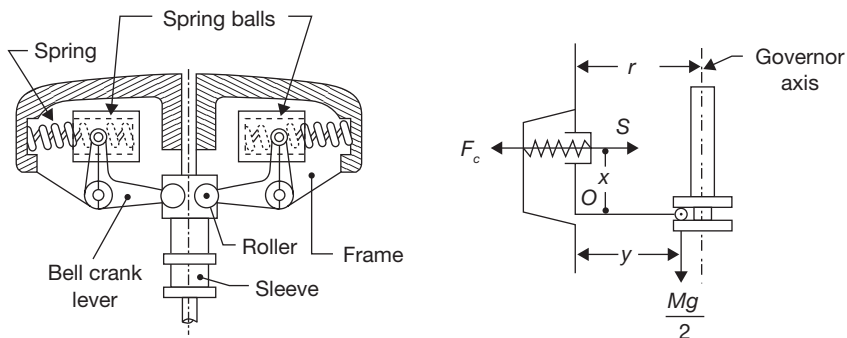
$F_C$  = centrifugal force,

$W$  = weight of sleeve,

$x$  and  $y$  = lengths of vertical and horizontal arms of bell crank lever respectively.

Taking moment about fulcrum  $O$ , we get

$$F_C \times x - S \times x = \frac{W}{2} \times y$$



**FIGURE 14.9**

Hartung Governor



**EXAMPLE 5.7**

In a Hartung type governor, ball arm and sleeve arm length are 80 mm and 100 mm respectively. The total travel of the sleeve is 15 mm. In the mid position, each spring is compressed by 40 mm and radius of rotation of mass center is 120 mm, each ball has a mass of 4 kg and spring has a stiffness of 10 kN/m in compression. The equivalent mass at governor sleeve is 15 kg. Neglecting the moment due to revolving masses and when the arms are inclined, determine the speed in the mid position.

**SOLUTION**

$$F_c = m\omega^2 r = 4 \times \omega^2 \times 0.120 \text{ m} = 0.48 \omega^2 \text{ N}$$

Spring force,  $S = \text{Stiffness} \times \text{Initial compression} = 10 \times 10^3 \text{ N/m} \times 0.04 \text{ m} = 400 \text{ N}$

$$F_c \times x - S \times x = \frac{W}{2} \times y$$

$$0.48\omega^2 \times 0.08\text{m} - 400\text{N} \times 0.08\text{m} = \frac{15\text{kg} \times 9.81 \text{ m/sec}^2}{2} \times 0.10\text{m}$$

$$\omega^2 = 1,024.93$$

$$\omega = 32.01 \text{ rad/s.}$$

$$N = 305.87 \text{ rpm}$$

**14.8 ► SENSITIVENESS OF GOVERNORS**

A governor is said to be sensitive, if its change of speeds from no load to full load may be as small a fraction of the mean equilibrium speed as possible and the corresponding sleeve lift may be as large as possible.

Sensitiveness of a governor can be found by dividing the difference between the maximum and minimum equilibrium speeds by mean speed.

Let  $N_1 = \text{Minimum equilibrium speed}$

$N_2 = \text{Maximum equilibrium speed}$

$$N = \text{Mean equilibrium speed} = \frac{N_1 + N_2}{2}$$

$$\text{Sensitiveness of governor} = \frac{(N_2 - N_1)}{N} = \frac{2(N_2 - N_1)}{N_1 + N_2} = \frac{2(\omega_2 - \omega_1)}{\omega_1 + \omega_2}$$

## 14.9 ► GOVERNING OF I.C. ENGINES

Governing is an action to control the fuel supply so that the engine runs at practically constant speed. When the load on an engine increases the speed drops and when load decreases the speed increases. Thus to control the fluctuation in engine speed, fuel requirement increases during increasing load and fuel requirement decreases with decreasing load. Governors play an important role in controlling the supply of fuel according to load requirement. There are following methods of governing of an I.C. Engine.

### 14.9.1 Qualitative Governing

In this method, the amount of fuel entering the cylinder is varied by altering the stroke of the Oil Pump or by passing a part of fuel which would have otherwise been injected into the engine cylinder back to the oil tank or by delaying the closing of the suction valve in the fuel pump with the help of centrifugal governor. The supply of air remains constant but the supply of fuel is varied to control the quality of charge (air-fuel mixture). This method is widely used in oil engines besides being always used on two-stroke cycle engines in which the air-fuel mixture has to be admitted to the engine cylinder to drive out the burnt charge of the previous cycle.

### 14.9.2 Quantitative Governing

In this system quality of charge remains constant but the quantity of air-fuel mixture supplied to the engine is varied by means of centrifugal governors. Centrifugal governor regulates the throttle valve; whenever the engine starts running at higher speed due to decreasing load, the quantity of charge is reduced until the engine speed reaches to its normal speed. Similarly, whenever the engine runs at a lower speed due to increasing load, the quantity of charge is increased to increase the speed to normal speed.

### 14.9.3 Hit and Miss Governing

This method is used for smaller gas engines. In this system, whenever the engine starts running at higher speed, some explosions are missed or omitted. This is done with the help of governor in which the inlet valve of fuel is closed and the explosions are omitted till the engine speed reaches its normal value. The disadvantage is that method is that there is uneven turning moment due to missing of explosions and requires heavy flywheel. In this system of governing, whenever the engine starts running at higher speed (due to decreased

load), some explosion are omitted or missed. This is done with help of centrifugal governor in which the inlet valve of fuel is closed and the explosions are omitted till the engine speed reaches its normal value. The only disadvantage of this.

### 14.10 ► DIFFERENCES BETWEEN FLYWHEEL AND GOVERNORS

Difference between flywheel and governors are shown in Table 14.1

**Table 14.1: Difference between Flywheel and Governors**

Flywheel	Governors
<ol style="list-style-type: none"> <li>1. It is provided on the engine and fabricating machines viz., rolling mills; punching machines; shear machines, presses, etc.</li> <li>2. Its function is to store available mechanical energy when it is in excess of the load required and to part with the same when the available energy is less than that required by the load.</li> <li>3. In engines, it takes care of fluctuations of speed during thermodynamic cycle.</li> <li>4. It works continuously from cycle to cycle.</li> <li>5. In fabrication machines, it is very economical to use it as its use reduces capital investment on prime movers and their running expenses.</li> </ol>	<ol style="list-style-type: none"> <li>1. It is provided on prime movers such as engines and turbines.</li> <li>2. Its function is to regulate the supply of driving fluid producing energy; according to the load requirements so that at different loads almost a constant speed is maintained.</li> <li>3. It takes care of fluctuation of speed due to the variation of load over a range of working of engines and turbines.</li> <li>4. It works intermittently, i.e., only when there is a change in the load.</li> <li>5. But for governor, there would have been unnecessarily more consumption of driving fluid thus it economizes its consumption.</li> </ol>

## RECAP ZONE .....



### Points to Remember

- The **flywheel** is an internal energy-storage device. It absorbs mechanical energy and during the period when the supply of energy is more than the requirement and releases it during the period when the requirement of energy is more than the supply.
- The function of the flywheel is to store excess energy during the power stroke and it supplies energy during another stroke.
- The main function of a flywheel is to smoothen out variations in the speed of a shaft caused by torque fluctuations.
- **Governor** takes care of the change of speed due to load variation over periods of the engine's running and tends to keep it as close to the mean speed as possible.
- The function of the governor is to adjust the supply of fuel according to the load requirements so as to keep the speeds at various loads, as close to the mean speed as possible.
- The **height of governor** is the vertical distance between the center of the governor balls and the point of intersection between the upper arms on the axis of the spindle.
- The speed at which the governor balls, the arms, etc. are in complete equilibrium and the sleeve does not tend to move upward or downward is called the equilibrium speed.

- The vertical distance the sleeve travels due to change in the equilibrium speed is called the sleeve lift. The vertical downward travel may be termed as a negative lift.
- The mean force acting on the sleeve for a given change of speed or lift of the sleeve is known as the governor effort.
- The force acting radially inward upon the rotating balls to counteract its centrifugal force is called the controlling force.
- This is an extreme case of sensitiveness. When the equilibrium speed is constant for all radii of rotation of the balls within the working range, the governor is said to be in isochronisms.
- The phenomenon of continuous fluctuation of the engine speed above and below the mean speed is termed as hunting.
- A governor is said to be sensitive, if its change of speeds from no load to full load may be as small a fraction of the mean equilibrium speed as possible and the corresponding sleeve lift may be as large as possible.
- In Inertia and Flywheel Governors, the inertia forces caused by the angular acceleration of the engine shaft or flywheel by a change in speed are utilized for the movement of the balls.
- In **Centrifugal Governors**, the change in centrifugal forces of the rotating masses due to change in the speed of the engine is utilized for movement of the governor sleeve.
- In **Watt governor**, the balls are mounted at the junction of the two arms; the upper arms are connected to the spindle and lower arms are connected to the sleeve.

## Important Formulae

1. Coefficient of fluctuation of speed:  $K_f = \frac{\omega_{\max} - \omega_{\min}}{\omega}$
2. Fluctuation in energy:  $\Delta E = \frac{1}{2} I \frac{(\omega_1 - \omega_2)}{\omega} \times 2\omega^2 = I \times K_f \times \omega^2$
3. Height of Watt governor:  $h = \frac{g}{\omega^2} = \frac{9.81 \times 60 \times 60}{4 \times \pi^2 \times N^2} = \frac{895}{N^2}$
4. Height of porter governor:  $h = \frac{g}{\omega^2} \left\{ 1 + \frac{(W \pm f)}{2w} (1 + K) \right\}$
5. Height of proell governor:  $h = \frac{FM}{BM} \times \frac{g}{\omega^2} \left[ 1 + \frac{W}{2w} \times (1 + K) \right]$
6. Total lift in Hartnell governor: Total lift =  $\frac{b}{a} (r_2 - r_1)$
7. Willson-Hartnell governor:  $4S_a + \frac{S_b}{2} \times \left( \frac{b}{a} \times \frac{y}{x} \right)^2 = \frac{F_{C_2} - F_{C_1}}{(r_2 - r_1)}$
8. Sensitiveness of governor:  $\frac{(N_2 - N_1)}{N} = \frac{2(N_2 - N_1)}{N_1 + N_2} = \frac{2(\omega_2 - \omega_1)}{\omega_1 + \omega_2}$



## REVIEW ZONE

### Multiple-choice Questions

- A flywheel:
  - Is provided to minimize the engine vibration
  - Is provided to control engine speed
  - Controls output fluctuation and input accordingly
  - All of the above
- The speed variation in engine caused by the fluctuations of engine turning moment is controlled by a:
  - Slide valve
  - Governor
  - Flywheel
  - None of these
- Ratio of difference between the maximum and minimum speed to that of mean speed is known as:
  - Sensitiveness of governor
  - Isochronisms in the governor
  - Stability of governor
  - None of these
- A governor is said to be sensitive, when:
  - The ratio of the difference of maximum and minimum equilibrium speeds to mean speed is maximum
  - Governor readily responds to a small variation of speed
  - Displacement of the sleeve is maximum for a small change of speed
  - All of the above
- A governor is said to be stable, when:
  - There is a minimum change in radius of governor weights at operating speed
  - There is one radius of governor weights for each equilibrium speed
  - The position of balls does not change within the operating speed
  - The position of balls changes within permissible limits
- Isochronism in a governor is required when:
  - One speed is required for all loads
  - One speed is required under one load
  - Engine runs at high speed
  - Engine runs at low speed
- When a governor is over sensitive, the sleeve will oscillate between two extreme positions on a slight change of speed. The governor is said to be:
  - Isochronous
  - Stable
  - Unstable
  - Hunting
- Mean force exerted by governor on the sleeve for a given variation of speed is known as:
  - Sensitiveness of governor
  - Stability of governor
  - The effort of governor
  - None of these
- Dead weight governor is:
  - Porter governor
  - Watt governor
  - Hartnell governor
  - All of the above
- Pendulum type governor is:
  - Hartnell governor
  - Watt governor
  - Porter Governor
  - All of the above
- Height of a Watt governor is:
  - Inversely proportional to the speed
  - Inversely proportional to the square of the speed
  - Directly proportional to the square of the speed
  - Directly proportional to the speed
- With increase in speed of governor:
  - The height of governor increases
  - The height of governor decreases
  - The radius of rotation increases
  - Both (b) and (c)
- As the sleeve of Porter governor moves upwards, the governor speed:
  - Increases
  - Decreases
  - Remain same
  - None of these
- The balls are attached to the extension of lower links in:
  - Hartnell governor
  - Watt governor
  - Porter governor
  - Proell governor
- In Hartnell governor, the compression of the spring as compared to lift of the sleeve is:
  - More
  - Less
  - Same
  - None of these
- If the stiffness of spring the Hartnell governor is increased, the governor will become:
  - More sensitive
  - Less sensitive
  - Remain same
  - None of these
- In a flywheel, the maximum fluctuation of energy is the:
  - The sum of the maximum and minimum energy

- (b) The difference between the maximum and minimum energy  
 (c) The ratio of maximum and minimum energy  
 (d) The ratio of mean resisting torque to the work done per cycle
18. In a turning moment diagram, the variation of energy above and below the mean resisting torque line is called:  
 (a) Fluctuation of energy  
 (b) Maximum fluctuation of energy  
 (c) The coefficient of fluctuation of energy  
 (d) None of these
19. The ratio of maximum fluctuation of energy to \_\_\_\_ is called coefficient of fluctuation of energy.  
 (a) Minimum fluctuation of energy  
 (b) Work done per cycle  
 (c) Both (a) and (b)  
 (d) None of these
20. Maximum fluctuation of energy in a flywheel is equal to:  
 (a)  $I\omega(\omega_1 - \omega_2)$   
 (b)  $I\omega_2 C_s$   
 (c)  $2E_s C_s$   
 (d) All of the above

## Answers

- |         |         |         |         |         |         |
|---------|---------|---------|---------|---------|---------|
| 1. (d)  | 2. (c)  | 3. (a)  | 4. (d)  | 5. (b)  | 6. (a)  |
| 7. (d)  | 8. (c)  | 9. (a)  | 10. (c) | 11. (b) | 12. (d) |
| 13. (a) | 14. (d) | 15. (c) | 16. (b) | 17. (b) | 18. (a) |
| 19. (b) | 20. (d) |         |         |         |         |

## Theory Questions

- What is a function of a flywheel? How does it differ from a governor?
- Define the term coefficient of fluctuation of energy and coefficient of fluctuation of speed in a flywheel.
- Derive the expression for maximum fluctuation of energy in a flywheel.
- What is a function of governors? Explain in detail.
- Classify the various types of governors. Differentiate between centrifugal and inertia types of governors.
- Write short notes on (a) sensitiveness of governor (b) isochronisms of governor (c) hunting of governor.
- \* What is governor? What are the various types of governors? Explain watt governor with neat sketch.
- \*8. Differentiate between the functions of governor and flywheel.

\* indicates that similar questions have appeared in various university examinations.

## Numerical Problems

1. A motor of 5 kW running at 950 rpm is used in a riveting machine. A flywheel is attached to the machine has a mass of 100 kg and radius of gyration of 0.4 m. Each riveting takes 1 second and requires 10 kW. Determine: (i) the number of rivets used per hour, and (ii) the fall in speed of the flywheel after the riveting operation.
2. A steam engine of 100 kW runs at 100 rpm. The speed of the engine is to be maintained within 1% variation in mean speed. The flywheel has a mass of 2000 kg and radius of gyration of 1 m. Determine the coefficient of fluctuation of energy.
3. An electric motor drives a punching press. A flywheel fitted to the press has a radius of gyration 0.4 m and runs at 240 rpm. The press is capable of punching 600 holes per hour with each punching operation taking 1.5 seconds and requiring 10000 N-m of work. Determine the rating of the machine in kW and the mass of the flywheel if the speed of the flywheel does not drop below 220 rpm.
4. A porter governor has an equal arm's length of 220 mm long and pivoted at the axis of rotation. Each ball has a mass of 5 kg and the mass of central load on the sleeve is 20 kg. When the governor begins to lift, the radius of rotation of the ball is 100 mm and 120 mm when the governor is at maximum speed. Find the minimum and maximum speeds and range of speed of the governor.
5. A Proell governor has an equal arm's length of 420 mm. The upper and lower ends of the arms are pivoted on the axis of the governor. The extension arms of the lower links are each 80 mm long and parallel to the axis when the radii of rotation of the balls are 160 mm and 220 mm. The mass of each ball is 12 kg and mass of the central load is 60 kg. Determine the range of the speed of the governor.

# Power Transmission Devices

## Learning Objectives

*By the end of this chapter, the student will be able:*

- To understand the concept of power transmission
- To demonstrate the various means of power transmission such as belt, rope, chain and gear drive
- To describe the application of the different types of gears for power transmission

### 15.1 ► INTRODUCTION

Power transmission is a process to transmit motion from one shaft to another by using some connection between them like belt, rope, chain, and gears. To connect the shafts, mainly two types of connectors are used, one is flexible and other is rigid. In a flexible type of connection, there is a relative velocity between shaft and connectors due to slip and strain produced in the connectors. But in the case of rigid connection, there is no relative velocity between the connector and shaft.

Belt, rope, and chain are flexible connectors where gears are rigid connectors. Generally, belt, rope, and chain drives are used when the distance between the shafts are large and gears are used when the distance between the shafts is very small. The efficiency of a gear drive is much more than that of the belt, rope, chain drive due to the absence of slipping effect.

### 15.2 ► BELT DRIVE

In belt drive, the velocity of two shafts can be varied by variation of diameter of the pulley on which belt is mounted. But in the chain or gear drive, the velocity of two shafts is varied by variation in the number of teeth on sprocket and gear, respectively. If an un-stretched belt

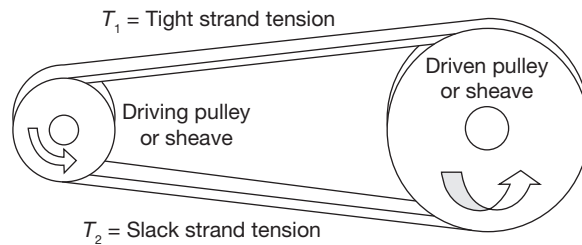


mounted on the pulleys, the outer and inner faces of belt become in tension and compression, respectively. In between the section, there is a neutral section which has no tension or compression. Usually, this is considered at the half of thickness of the belt. The effective radius of rotation of a pulley is obtained by adding half the belt thickness to the radius of the pulley. A schematic diagram of the belt drive is shown in Figure 15.1.

### 15.2.1 Type of Belt Cross-sections

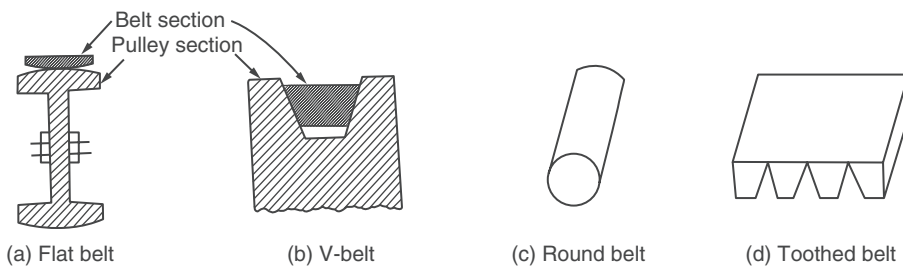
Figure 15.2 shows the flat and V-belt. In flat belt drive, the rim of the pulley is slightly crowned which helps to keep the belt running centrally on the pulley rim as shown in Figure 15.2 (a). For V-belt drive, grooves are made on the rim of the pulley for wedging action. The belt does not touch the bottom of the groove as shown in Figure 15.2 (b). Owing to wedging action, v-belts need a little adjustment and transmit more power, without slip, as compared to flat belts. In multiple V-belt systems, more than one belt on the pulleys can be used to increase the power transmission capacity.

**Round Belts:** Round belts as shown in Figure 15.2 (c) are generally made of rubber. This type of belt is generally used for light loads, such as in a sewing machine or a vacuum cleaner.



**FIGURE 15.1**

Belt Drive



**FIGURE 15.2**

Type of Belt Cross-sections

**Timing/Toothed Belts:** Timing belts or toothed belts [as shown in Figure 15.2 (d)] use their teeth for power transmission, as opposed to friction. This configuration results in no slippage, and therefore, the driving and driven shafts remain synchronized. It is more expensive to manufacture due to the complexity of the belt and pulley shapes.

### 15.2.2 Velocity Ratio

Velocity ratio is the ratio of the speed of the driven pulley to that of the driving pulley.

Let  $N_1$  is rotational speed of the driving pulley,

$N_2$  is rotational speed of the driven pulley,

$D_1$  is diameter of driving pulley,

$D_2$  is diameter of driven pulley,

$t$  is the thickness of the belt.

$$V = \frac{\pi(D_1 + 2t)N_1}{60} = \frac{\pi(D_2 + 2t)N_2}{60}$$

i.e.,  $D_1N_1 = D_2N_2$ ; where  $t$  is very small in comparison to  $D$ , therefore it can be neglected.

$$V.R = \frac{N_2}{N_1} = \frac{D_1}{D_2}$$

**Slip:** The effect of slip is a decrease in the speed of belt on driving shaft and the driven shaft.

Let  $\omega_1$  is angular velocity of driving pulley,

$\omega_2$  is angular velocity of driven pulley,

$S_1$  is percentage slip between driving pulley and belt,

$S_2$  is percentage slip between driven pulley and belt, and

$S$  is total percentage slip.

$$\text{Peripheral speed of the driving pulley} = \frac{\omega_1 D_1}{2}$$

$$\text{Speed of belt on driving pulley} = \frac{\omega_1 D_1}{2} \left[ \frac{100 - S_1}{100} \right]$$

This is also the speed of belt on driven pulley.

$$\text{Now, peripheral speed of driven pulley} = \frac{\omega_1 D_1}{2} \left( \frac{100 - S_1}{100} \right) \left( \frac{100 - S_2}{100} \right)$$

$$\text{If } S \text{ is total slip percentage, peripheral speed of driven pulley} = \frac{\omega_1 D_1}{2} \left( \frac{100 - S}{100} \right)$$

$$\text{or} \quad \frac{\omega_1 D_1}{2} \left( \frac{100 - S_1}{100} \right) \left( \frac{100 - S_2}{100} \right) = \frac{\omega_1 D_1}{2} \left( \frac{100 - S}{100} \right)$$

$$\text{or } S = S_1 + S_2 - 0.01S_1S_2$$

$$\text{Thus, velocity ratio, V.R} = \frac{D_1}{D_2} \left( \frac{100 - S}{100} \right) = \frac{N_2}{N_1}$$

### 15.2.3 Creep

When belt passes from slack to tight side, a certain portion of belt extends and again contracts when belt passes through tight to slack side. Due to fluctuation in length of the belt, there is relative motion between belt and pulley surface. This relative motion is known as creep. Considering the creep, velocity ratio can be expressed as:

$$\frac{N_2}{N_1} = \frac{D_1}{D_2} \times \frac{E + \sqrt{\sigma_2}}{E + \sqrt{\sigma_1}}$$

Where  $N_1$  and  $N_2$  are the speeds of driving and driven pulleys, respectively;  $D_1$  and  $D_2$  are the diameters of the driver and driven pulleys, respectively;  $\sigma_1$  and  $\sigma_2$  are the stresses developed in the tight and slack side of the belt, respectively; and  $E$  is the modulus of elasticity of belt materials.

### 15.2.4 Flat Belt Drives

Belts are classified into many types according to usage, position, shape like flat, v-belt, round ropes, etc., but Belt drives are different from the belts, these are described as the combination of pulleys according to their position and also their carrying or transmitting power from one pulley to another pulley. Flat belts drives are classified as:

- |                             |                         |
|-----------------------------|-------------------------|
| (a) Open belt drive         | (b) Crossed belt drive  |
| (c) Quarter turn belt drive | (d) Compound belt drive |

#### EXAMPLE 15.1

The speed of a driving shaft is 100 rpm and the speed of the driven shaft is 150 rpm. The diameter of the driving pulley is given as 500 mm, find the diameter of the driven pulley in the following cases:

- (i) If the belt thickness is negligible,
- (ii) If the belt thickness is 6 mm,
- (iii) If total slip is 5% considering thickness of belt, and
- (iv) If a slip is 2% on each pulley considering the thickness of the belt.

**SOLUTION**

$$(i) \quad \frac{N_1}{N_2} = \frac{D_2}{D_1} \Rightarrow D_2 = D_1 \times \frac{N_1}{N_2} = 500 \text{ mm} \times \frac{100 \text{ rpm}}{150 \text{ rpm}} = \mathbf{333.33 \text{ mm}}$$

$$(ii) \quad \frac{N_1}{N_2} = \frac{D_2 + t}{D_1 + t} \Rightarrow D_2 = (D_1 + t) \times \frac{N_1}{N_2} - t$$

$$D_2 = (500 \text{ mm} + 6 \text{ mm}) \times \frac{100 \text{ rpm}}{150 \text{ rpm}} - 6 \text{ mm} = \mathbf{331.33 \text{ mm}}$$

$$(iii) \quad \frac{N_2}{N_1} = \frac{D_1 + t \left( \frac{100 - S}{100} \right)}{D_2 + t}$$

$$\text{or } \frac{150 \text{ rpm}}{100 \text{ rpm}} = \left( \frac{500 \text{ mm} + 6}{D_2 + 6} \right) \left( \frac{100 - 5}{100} \right)$$

$$\Rightarrow D_2 = \frac{100 \text{ rpm}}{150 \text{ rpm}} \left( \frac{100 - 5}{100} \right) (500 \text{ mm} + 6 \text{ mm}) - 6 \text{ mm} = \mathbf{314.46 \text{ mm}}$$

$$(iv) \quad \frac{N_2}{N_1} = \frac{D_1 + t \left( \frac{100 - S}{100} \right)}{D_2 + t};$$

$$\text{where } S = S_1 + S_2 - 0.01 S_1 \times S_2 = 2 + 2 - 0.01 \times 2 \times 2 = 3.96$$

$$D_2 = \frac{100 \text{ rpm}}{150 \text{ rpm}} \left( \frac{100 - 3.96}{100} \right) (500 \text{ mm} + 6 \text{ mm}) - 6 \text{ mm} = \mathbf{317.97 \text{ mm}}$$

**A. Open Belt Drive**

The open belt drive is used to provide the same direction of rotation to the driven shaft as the direction of rotation of the driving shaft.

Let  $L$  is length of belt for open drive,

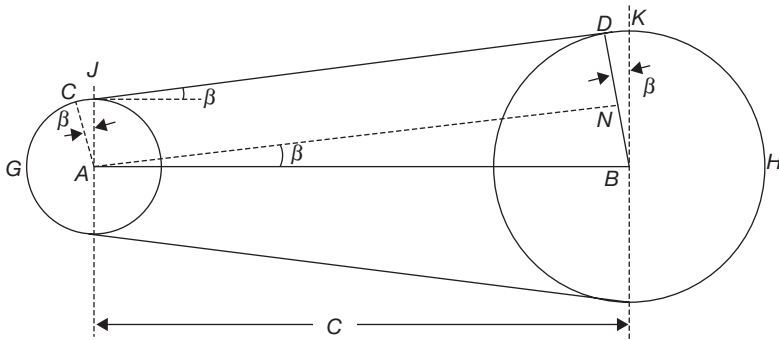
$r$  is the radius of the smaller pulley,

$R$  is radius of larger pulley,

$C$  is center distance between pulleys,

$\beta$  is angle subtended by each common tangent on the center of the pulley (CD or EF),

$AB$  is the line joining the centers of pulleys.



**FIGURE 15.3**  
Open Belt Drive

From Figure 15.3,

$$\angle CAJ = \angle NAB = \beta$$

$$L = 2[\text{Arc } GC + CD + \text{Arc } DH] = 2\left[\left(\frac{\pi}{2} - \beta\right)r + AN + \left(\frac{\pi}{2} + \beta\right)R\right]$$

$$= \pi(R+r) + 2\beta(R-r) + 2C \cos \beta$$

for small angle  $\beta$ ,  $\sin \beta = \frac{R-r}{C}$  and  $\cos \beta = \sqrt{1 - \sin^2 \beta} \cong 1 - \frac{1}{2} \sin^2 \beta = 1 - \frac{1}{2} \left(\frac{R-r}{C}\right)^2$

Putting the value of  $\beta$  and  $\cos \beta$  in equation of  $L$ , we get

$$L = \pi(R+r) + 2C + \frac{(R-r)^2}{C}$$

### B. Crossed Belt Drive

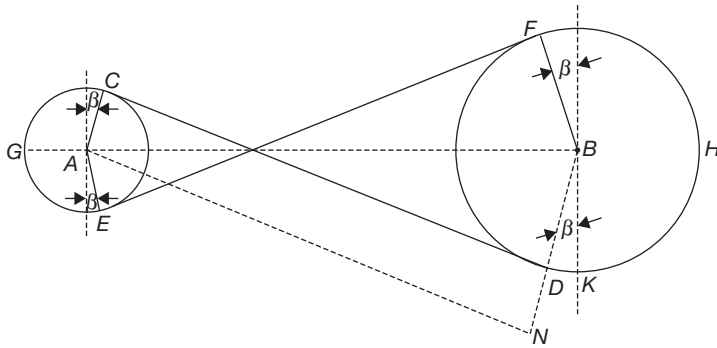
The cross-belt drive is used to provide reverse direction of rotation to the driven shaft as the direction of rotation of the driving shaft.

Similar to open belt drive, let  $A$  and  $B$  be the pulley centers and  $CD$  and  $EF$  be the common tangents to the two pulleys as shown in Figure 15.4.

In Figure 7.4, Belt length,  $L = 2[\text{Arc } GC + CD + \text{Arc } DH]$

$$\text{or, } L = \left[2\left(\frac{\pi}{2} + \beta\right)r + C \cos \beta + \left(\frac{\pi}{2} + \beta\right)R\right] = [(\pi + 2\beta)(R+r) + 2C \cos \beta]$$

As  $\beta = \sin \beta = \frac{R+r}{C}$  since  $\beta$  is very small.

**FIGURE 15.4**

Crossed-belt Drive

$$\cos \beta = \left( 1 - \frac{1}{2} \beta^2 \right) = 1 - \frac{1}{2} \left( \frac{R+r}{C} \right)^2$$

$$\text{or, } L = \left[ \pi + 2 \left( \frac{R+r}{C} \right) \right] (R+r) + 2C \left[ 1 - \frac{1}{2} \left( \frac{R+r}{C} \right)^2 \right]$$

$$L = \pi(R+r) + 2C + \frac{(R+r)^2}{C}$$

### C. Quarter Turn Drive

In quarter turn drive, the two axes of pulleys are the right angle to each other as shown in Figure 15.5 (c) and (d). These drives are used in industries for parallel power to tangential power transmission.

#### EXAMPLE 15.2

Two shafts drive are arranged parallel to each other at a distance of 5 m. If the pulley diameters mounted on the shafts are 500 mm and 750 mm. Determine the difference in length of the belts for opposite direction of rotation and the same direction of rotation.

#### SOLUTION

For opposite direction of rotation crossed belt drive is used and for the same direction of rotation open belt drive is used.

For crossed belt drive:

$$\begin{aligned}
 L &= \pi(R+r) + 2C + \frac{(R+r)^2}{C} \\
 &= \frac{\pi \times (500 \text{ mm} + 750 \text{ mm}) \times 10^{-3}}{2} + 2 \times 5 \text{ m} + \left( \frac{500 \text{ mm} + 750 \text{ mm}}{2} \right)^2 \times 10^{-6} \times \frac{1}{5 \text{ m}} \\
 &= 12.041 \text{ m}
 \end{aligned}$$

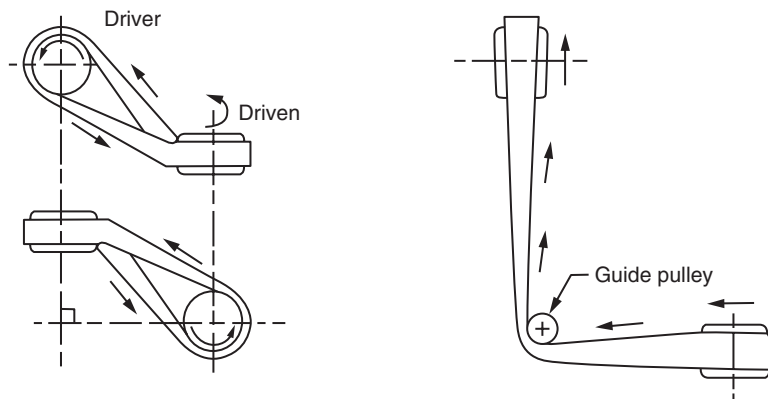
For open belt drive:

$$\begin{aligned}
 L &= \pi(R+r) + 2C + \frac{(R-r)^2}{C} \\
 &= \frac{\pi \times (500 \text{ mm} + 750 \text{ mm}) \times 10^{-3}}{2} + 2 \times 5 \text{ m} + \left( \frac{750 \text{ mm} - 500 \text{ mm}}{2} \right)^2 \times 10^{-6} \times \frac{1}{5 \text{ m}} \\
 &= 11.966 \text{ m}
 \end{aligned}$$

Difference in length of cross belt and open belt =  $12.041 \text{ m} - 11.966 \text{ m} = 0.0743 \text{ m}$

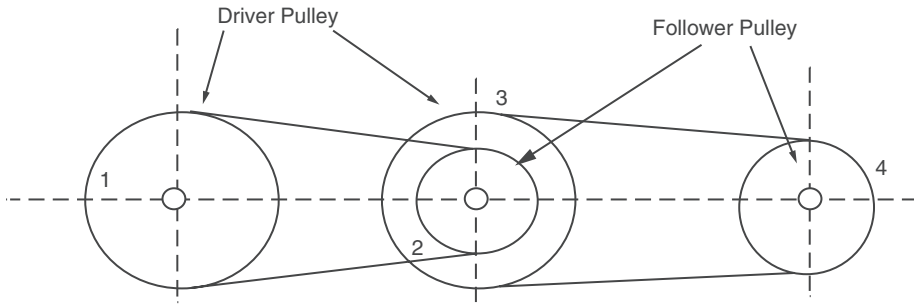
## D. Compound Belt Drives

In these, the axes of pulleys are not parallel to each other compound belt drives are shown in Figure 15.6 and these compound belt drives are used to transmit power in any direction and it uses a number of pulleys.



**FIGURE 15.5**

Quarter Turn Belt Drive



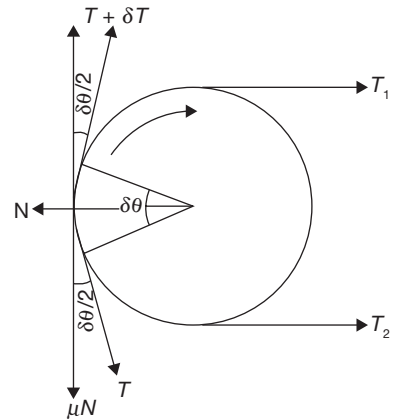
**FIGURE 15.6**  
Compound Belt Drive

### 15.2.5 Ratio of Tensions

- Let  $T_1$  is the tension in tight side of the belt,
- $T_2$  is the tension in slack side of the belt,
- $\theta$  is the angle of the lap of the belt over the pulley,
- $\mu$  is coefficient of friction between the belt and pulley.

Consider a short length of a belt of belt subtending an angle  $\delta\theta$  at the center of the pulley as shown in Figure 15.7.

- Let  $N$  is a normal reaction between the element length of a belt and the pulley,
- $\delta T$  is the increase in tension in tight side than that on slack side,
- $T + \delta T$  is the tension on the tight side of the element.



**FIGURE 15.7**  
Tensions in Belt

Resolving the force in tangential direction,

$$\mu N + T \cos \delta\theta / 2 - (T + \delta T) \cos \delta\theta / 2 = 0$$

As  $\delta\theta$  is very small,  $\cos \delta\theta / 2 \cong 1$ .

$$\mu N + T - T - \delta T = 0 \quad \text{or,} \quad \delta T = \mu N \tag{15.1}$$

Resolving the force in radial direction,

$$N - T \sin \delta\theta / 2 - (T + \delta T) \sin \delta\theta / 2 = 0$$

As  $\delta\theta$  is very small,  $\sin \delta\theta / 2 \cong \delta\theta / 2$ .

$$N - T \delta\theta / 2 - T \delta\theta / 2 - \delta T \delta\theta / 2 = 0$$

Neglecting the product of two small quantities

$$N = T \delta\theta \tag{15.2}$$



From Equations (15.1) and (15.2),  $\delta T = \mu T \delta \theta$  or  $\frac{\delta T}{T} = \mu \delta \theta$

On integration, we get

$$\int_{T_2}^{T_1} \frac{\delta T}{T} = \int_0^{\theta} \mu \delta \theta \Rightarrow \frac{T_1}{T_2} = e^{\mu \theta}$$

In V - belt,  $\frac{T_1}{T_2} = e^{\mu \theta / \sin \alpha}$ , Where  $\alpha$  is the angle made by V-section of the belt.

### Power Transmission in Belt Drive

$$P = T_{\text{resultant}} \times \text{Velocity}$$

$$= (T_1 - T_2) \times V, \quad \text{where P is power transmitted in watt and V is velocity of belt.}$$

$$= T_1 \left( 1 - \frac{T_2}{T_1} \right) \times V = T_1 \left( 1 - \frac{1}{e^{\mu \theta}} \right) \times V$$

$$= T_1 \left( \frac{e^{\mu \theta} - 1}{e^{\mu \theta}} \right) \times V, \quad \text{watt}$$

### EXAMPLE 15.3

Two pulleys of diameters 500 mm and 200 mm are mounted on two parallel shafts 2 m apart. These shafts are connected by a cross belt. Find the angle of contact of belt and pulley. If larger pulley rotates at 250 rpm and maximum permissible tension in the belt is 1 kN, find the power transmitted by the belt. Assume coefficient of friction between belt and pulley is 0.25.

### SOLUTION

For crossed belt

$$\sin \beta = \frac{r_1 + r_2}{C} = \frac{100 \text{ mm} + 250 \text{ mm}}{2000 \text{ mm}} = 0.175 \Rightarrow \beta = 10.07^\circ$$

$$\theta = 180^\circ + 2\beta = 180^\circ + 2 \times 10.07^\circ = 200.15^\circ = 200.15^\circ \times \frac{\pi}{180^\circ} = 3.493 \text{ radian}$$

$$\frac{T_1}{T_2} = e^{\mu \theta} = e^{0.25 \times 3.493} = 2.3946$$

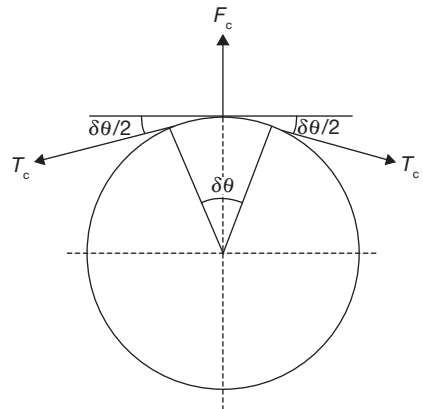
$$\Rightarrow T_2 = \frac{T_1}{2.3946} = \frac{1000 \text{ N}}{2.3946} = 417.592 \text{ N}$$

$$\begin{aligned}
 P &= (T_1 - T_2)V = (T_1 - T_2) \frac{\pi D_1 N_1}{60} \\
 &= (1000\text{ N} - 417.592\text{ N}) \times \frac{\pi \times 500\text{ mm} \times 250\text{ rpm}}{60\text{ sec}} = 3.811\text{ kW}
 \end{aligned}$$

### 15.2.6 Effect of Centrifugal Force on Belt Drive

When the velocity of the belt is more than 10 m/sec, the centrifugal force due to self-weight of the belt becomes predominant. Analyze the various components of forces as shown in Figure 15.8.

Let  $\rho$  is the density of belt materials,  
 $T_c$  is centrifugal tension on the belt element in tight and slack side,  
 $r$  is the radius of the pulley,  
 $t$  is the thickness of the belt,  
 $b$  is the width of the belt,  
 $\sigma$  is maximum allowable stress in the belt,  
 $m$  is mass per unit length of the belt,  
 $F_c$  is the centrifugal force on the element,  
 $V$  is the velocity of the belt, and  
 $\Delta\theta$  is the angle of the lap.



**FIGURE 15.8**

Centrifugal Force in Belt Drive

Now,

$$\begin{aligned}
 F_c &= (\text{length of belt element} \times \text{mass per unit length}) \\
 &\quad \times \text{acceleration}
 \end{aligned}$$

$$F_c = rd\theta \times bt \times \rho \frac{V^2}{r} = \rho V^2 \times bt \times \delta\theta \quad (15.3)$$

$$\text{Also, } F_c = 2T_c \sin \delta\theta / 2 = 2T_c \times \delta\theta / 2 = T_c \times \delta\theta \quad (15.4)$$

From Equation (15.3) and (15.4),

$$T_c = \rho(bt)V^2$$

Total tension on tight side,

$$T = T_1 + T_c;$$

where  $T$  is maximum allowable tension equal to  $\sigma \times b \times t$

Total tension on slack side =  $T_2 + T_c$

$$\begin{aligned}\text{Now, Power } P &= T_1 \left( \frac{e^{\mu\theta} - 1}{e^{\mu\theta}} \right) \times V = (\sigma bt - \rho V^2 bt) \left( \frac{e^{\mu\theta} - 1}{e^{\mu\theta}} \right) \times V \\ &= bt (\sigma - \rho V^2) \left( \frac{e^{\mu\theta} - 1}{e^{\mu\theta}} \right) \times V\end{aligned}$$

For maximum power transmission,  $\frac{\partial P}{\partial V} = 0$

$$\text{or, } bt (\sigma - 3\rho V^2) \left( \frac{e^{\mu\theta} - 1}{e^{\mu\theta}} \right) = 0$$

$$\text{or, } \sigma = 3\rho V^2$$

$$\text{or, } V = \sqrt{\frac{\sigma}{3\rho}} = \sqrt{\frac{T}{3m}}$$

Initial tension in the belt,  $T_0 = (T_1 + T_2)/2$

### EXAMPLE 15.4

A leather belt of density  $1000 \text{ kg/m}^3$ , thickness  $10 \text{ mm}$  is used to transmit a power of  $8 \text{ kW}$  from a pulley  $1.5 \text{ m}$  in diameter running at  $300 \text{ rpm}$ . Determine the width of the belt taking centrifugal tension into account. If the angle of the lap is  $165^\circ$  and coefficient of friction between belt and pulley is  $0.25$ . Assuming allowable stress for the leather belt is  $1.5 \text{ Mpa}$ .

### SOLUTION

$$V = \frac{\pi D_1 N_1}{60} = \frac{\pi \times 1.5 \text{ m} \times 300 \text{ rpm}}{60} = 23.56 \text{ m/sec.}$$

$$\theta = 165^\circ = 165^\circ \times \frac{\pi}{180^\circ} = 2.879 \text{ radian}$$

$$\frac{T_1}{T_2} = e^{\mu\theta} = e^{0.25 \times 2.879} = 2.054$$

$$T_1 = 2.054 T_2 \quad (15.5)$$

$$P = (T_1 - T_2)V \quad \text{or} \quad 8 \times 10^3 \text{ W} = (T_1 - T_2) \times 23.56 \text{ m/sec}$$

$$T_1 - T_2 = \frac{8 \times 10^3 \text{ W}}{23.56 \text{ m/sec}} = 339.558 \text{ N} \quad (15.6)$$

From Equation (15.5) and (15.6), we get

$$2.054T_2 - T_2 = 339.558 \text{ N} \Rightarrow T_2 = \frac{339.558}{1.054} = 661.72 \text{ N}$$

Mass of the belt per unit length = Area  $\times$  density

$$m = b \times t \times \rho = b \times 0.01 \text{ m} \times 1000 \text{ kg/m}^3 = 10b \text{ kg.}$$

$$\text{Centrifugal tension} = mV^2 = 10b(23.56 \text{ m/sec})^2 = 5550.73b \text{ N}$$

Maximum tension in the belt =  $\sigma \times b \times t = 1.5 \times 10^6 \text{ Pa} \times b \times 0.01 \text{ m} = 15000b \text{ N}$

$$T = T_1 + T_c \text{ or } 15000b = 661.72 + 5550.73b$$

or 
$$b = \frac{661.72}{9449.264} = 0.07002 \text{ m} = \mathbf{70 \text{ mm}}$$

### EXAMPLE 15.5

An open belt drive transmits a power of 3.0 kW. The linear velocity of the belt is 3 m/sec. The angle of the lap on the smaller pulley is  $160^\circ$ . The coefficient of friction between belt and pulley is 0.25. Determine the effect on power transmission in the following cases:

- (i) Initial tension in the belt is increased by 10%.
- (ii) The angle of the lap is increased by 10% using idler pulley for the same speed and tension in the tight side.
- (iii) Coefficient of friction is increased by 10% for same initial tension.

### SOLUTION

$$P = 3 \text{ kW} = 3 \times 10^3 \text{ W}, \quad \theta = 160^\circ \times \frac{\pi}{180^\circ} = 2.792 \text{ radian}$$

$$\mu = 0.25, \quad V = 3 \text{ m/sec}, \quad P = (T_1 - T_2)V \text{ or } 3 \times 10^3 \text{ W} = (T_1 - T_2) \times 3 \text{ m/sec}$$

$$T_1 - T_2 = 1000 \text{ N}; \quad \frac{T_1}{T_2} = e^{\mu\theta} = e^{0.25 \times 2.792} = 2 \quad T_1 = 2T_2$$

$$\begin{aligned} \text{i.e., } 2T_2 - T_2 = 1000 \text{ N and } T_1 = 2T_2 = 2000 \text{ N; Initial Tension } T_0 &= \frac{T_1 + T_2}{2} \\ &= \frac{2000 \text{ N} + 1000 \text{ N}}{2} = 1500 \text{ N} \end{aligned}$$

(i) when initial tension increased by 10%

$$T_0' = 1500N \times \frac{110}{100} = 1650N$$

$$T_0' = \frac{T_1 + T_2}{2} = 1650N \Rightarrow T_1 + T_2 = 3300N$$

As  $\mu$  and  $\theta$  remain unchanged,  $T_1 = 2T_2$

$$2T_2 + T_2 = 3T_2 = 3300N \Rightarrow T_2 = 1100N \text{ and } T_1 = 2200N$$

$$P = (T_1 - T_2)V = (2200N - 1100N) \times 3 = 3300W$$

$$\text{Increase in power} = \frac{3300W - 3000W}{3000W} = \mathbf{10\%}$$

(ii)  $\frac{T_1}{T_2} = e^{\mu\theta}$

$T_1$  is the same as before whereas  $\theta$  is increased by 10%

$$\frac{2000}{T_2} = e^{0.25 \times 2.792 \times 1.1} = 2.155$$

$$\Rightarrow T_2 = 928.06N$$

$$P = (T_1 - T_2)V = (2000N - 928.06N) \times 3m / \text{sec} = 3215.82W$$

$$\text{Increase in power} = \frac{3215.82W - 3000W}{3000W} = \mathbf{7.1\%}$$

(iii) When frictional coefficient increases by 10%

$$\frac{T_1}{T_2} = e^{\mu\theta} = e^{0.25 \times 1.1 \times 2.792} = 2.155 \Rightarrow T_1 = 2.155T_2$$

$$2.155T_2 + T_2 = 3.155T_2 = 3000N \Rightarrow T_2 = 950.871N$$

$$T_1 = 2.155T_2 = 2.155 \times 950.871N = 2049.128N$$

$$P = (T_1 - T_2)V = (2049.128N - 950.871N) \times 3m / \text{sec} = 3294.772W$$

$$\text{Increase in power} = \frac{3294.772W - 3000W}{3000W} = \mathbf{9.82\%}$$

### 15.3 ► ROPE DRIVE

Rope drive is very similar to belt drive. It is classified as (i) Fiber ropes, and (ii) Wire ropes.

Fiber ropes are made of manila or cotton. Wire ropes are made of steel wires. A group of wires makes a strand and strands make a rope as shown in Figure 15.9. Each strand

is twisted with other strands. The rope may have 3-strands or 9-strands, and each strand may have 7-19 wires, depends on its application.

## 15.4 ► CHAIN DRIVE

To overcome the problem of slip in belt drive or rope drive, chain drive is used. A schematic diagram of the chain drive is shown in Figure 15.10. The velocity ratio in chain drive remains constant. But, chain drive is heavier than the belt drive and there is gradual stretching in its strength. Time to time some of its links have to be removed. Lubrication of its parts is also desired. The wheel over which chains are run, corresponding to the pulleys in a belt drive is known as sprocket having projected teeth that fit into the recess in the chain.

*Pitch:* Distance between two consecutive roller centers is known as pitch,  $p$ .

*Pitch Circle:* T circle drawn through the roller centers of a wrapped chain around a sprocket is called the pitch circle.

Let  $T$  is a number of teeth on a sprocket,

$\phi$  is angle subtended by a chord of the link at the center.

at the center.

$r$  is the radius of the pitch circle.

$$\frac{p}{2} = r \sin \phi / 2 = 2r \sin \frac{1}{2} \left( \frac{360^\circ}{T} \right) = 2r \sin \frac{180^\circ}{T}$$

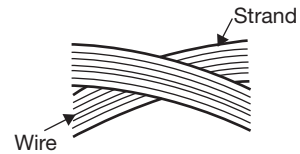
$$\text{or, } r = \frac{p}{2 \sin \frac{180^\circ}{T}} = \frac{p}{2} \operatorname{cosec} \frac{180^\circ}{T}$$

### 15.4.1 Chain Length

Let  $R$  and  $r$  are the radius of the pitch circle of two sprockets having teeth  $T$  and  $t$  respectively.

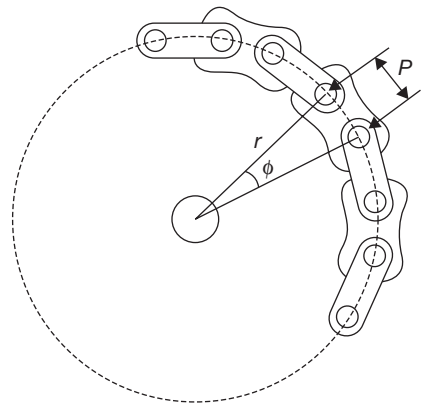
$L$  is the length of the chain,

$C$  is the center distance between sprockets =  $K.p$



**FIGURE 15.9**

A Schematic View of Rope



**FIGURE 15.10**

Chain Drive

$$L = \pi(R+r) + \frac{(R-r)^2}{C} + 2C$$

$$\text{Since } R = \frac{p}{2} \operatorname{cosec} \frac{180^\circ}{T} \text{ and } r = \frac{p}{2} \operatorname{cosec} \frac{180^\circ}{t}$$

$$\text{Now, } L = \frac{p \times (T+t)}{2} + \frac{\frac{p}{2} \left( \operatorname{cosec} \frac{180^\circ}{T} - \operatorname{cosec} \frac{180^\circ}{t} \right)^2}{K.p} + 2K.p$$

$$\text{or, } L = p \left[ \frac{(T+t)}{2} + \frac{\left( \operatorname{cosec} \frac{180^\circ}{T} - \operatorname{cosec} \frac{180^\circ}{t} \right)}{4K} + 2K \right]$$

### EXAMPLE 15.6

For reduction of speed from 250 rpm to 100 rpm, a chain drive is used. Calculate the number of teeth on the driving sprocket if a number of teeth on driven sprocket is 20. Pitch circle diameter of the driven sprocket is 650 mm and the center distance between sprockets is 100 mm. Also, determine the pitch and length of the chain.

### SOLUTION

$$N_1 = 250 \text{ rpm}, N_2 = 100 \text{ rpm}, T_1 = 20, T_2 = ?$$

$$r_2 = 325 \text{ mm}, C = 1000 \text{ mm} = 1 \text{ m}$$

$$N_1 \cdot T_1 = N_2 \cdot T_2 \quad \text{or} \quad T_2 = \frac{N_1 \times T_1}{N_2} = \frac{250 \text{ rpm} \times 20}{100 \text{ rpm}} = 50 \text{ Teeth}$$

$$\text{Pitch circle radius, } r_2 = 0.325 \text{ m} = \frac{p}{2} \operatorname{cosec} \frac{180^\circ}{T_2} = \frac{p}{2} \operatorname{cosec} \frac{180^\circ}{50}$$

$$p = 0.0408 \text{ m} = 40.8 \text{ mm}$$

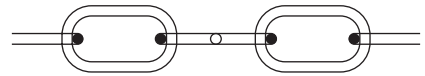
$$L = p \left[ \frac{(T_1 + T_2)}{2} + \frac{\left( \operatorname{cosec} \frac{180^\circ}{T} - \operatorname{cosec} \frac{180^\circ}{t} \right)}{4K} + 2K \right]$$

$$= 0.0408 m \left[ \frac{(20N + 50N)}{2} + \frac{\left( \operatorname{cosec} \frac{180^\circ}{20} - \operatorname{cosec} \frac{180^\circ}{50} \right)}{4 \times 1} + 2 \times 1 \right]$$

$$= 3.465 m$$

### 15.4.2 Types of Chain

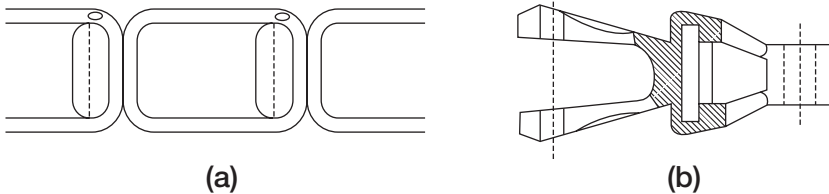
**Hosting Chain:** This type of chain is used for lower speed. It consists of oval links (Figure 15.11).



**FIGURE 15.11**

Hosting Chain

**Conveyor Chain:** Conveyor chain may be detachable/hook joint type/closed end pintle type as shown in Figure 15.12. The sprocket teeth are so shaped and spaced that the chain could run onto and off the sprockets smoothly and without interference. Such chains are used for low-speed applications.



**FIGURE 15.12**

(a) Hook Joint Type Conveyor Chain (b) Closed-end Pintle Type Conveyor Chain

### Power Transmission Chains

**Block Chain:** This is used for power transmission at low speed such as a bicycle, motorbike, etc. (Figure 15.13).

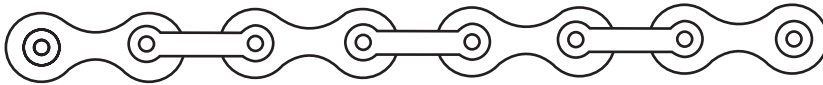


**FIGURE 15.13**

Block Chain

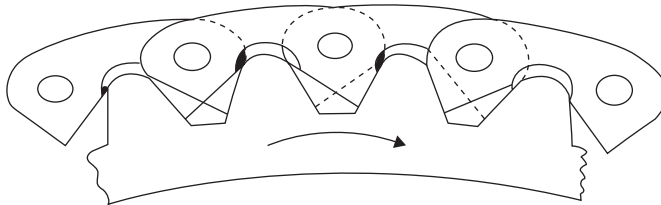
**Roller Chain:** A common form of roller chain is shown in Figure 15.14. A bush is fixed in inner link whereas the outer link has a pin fixed to it. There is only sliding motion between the pin and the Bush. The roller is made of hardened steel and is free to turn on the Bush. A good roller chain is quiet and wearless in comparison to a block chain.



**FIGURE 15.14**

Roller Chain

*Silent/Inverted Tooth Chain:* Roller chains can run at very high speed. But when maximum quietness is required, inverted tooth chains are required. It has no roller; the links are so shaped as to engage directly with the sprocket teeth and included angle is either  $60^\circ$  or  $75^\circ$  (Figure 15.15).

**FIGURE 15.15**

Silent or Inverted-tooth Chain

## 15.5 ► GEAR DRIVE

Gears are compact power transmission device that controls the speed, torque, and direction of rotation of the driven shaft. Gears may be classified into five main categories: Spur, Helical, Bevel, Hypoid, and Worm. Shaft orientation, efficiency, and speed determine the application of gear drive. Gears are a toothed disc, which transmits power from one shaft to another shaft by meshing with teeth of other gear.

### 15.5.1 Gear Terminology

All the important gear terminologies are shown in Figure 15.16.

*Pitch Point:* The point of contact between pitch circles of two gears is known as pitch point.

*Pitch Circle:* The circle passing through the point of contacts of two gears is known as pitch circle.

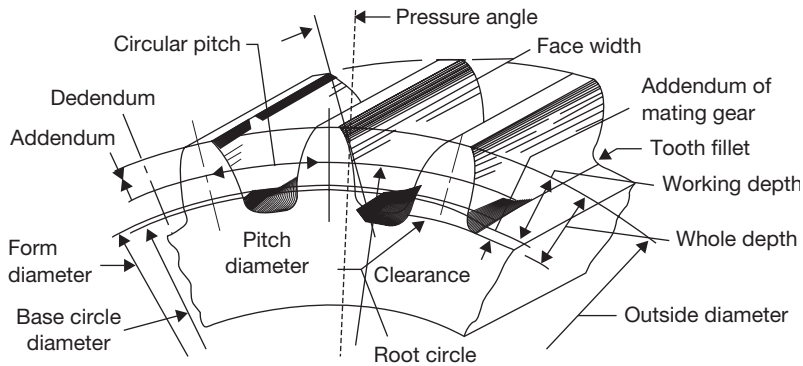
*Pitch Diameter,  $D$ :* Diameter of pitch circle is known as pitch diameter.  $D = \frac{N}{P_d} = \frac{N \times P_c}{\pi}$

*Circular Pitch,  $P_c$ :* It is the distance measured along the circumference of the pitch circle from a Point on one tooth of the corresponding point on the adjacent tooth.  $P_c = \frac{\pi D}{N} = \frac{\pi}{P_d}$

*Diametral Pitch,  $P_d$ :* It is the number of teeth per unit length of the pitch circle diameter.  $P_d = \frac{T}{D}$

*Module,  $m$ :* It is the ratio of pitch diameter to the number of teeth.

$$m = \frac{D}{T} = \frac{1}{P_d} = \frac{P_c}{\pi}$$

**FIGURE 15.16**

Nomenclature of Gear

*Gear Ratio:* It is the ratio of a number of teeth on gear and pinion.  $G = \frac{T}{t}$

*Velocity Ratio:* It is the ratio of the angular velocity of the driving gear to driven gear.

$$VR = \frac{\omega_1}{\omega_2} = \frac{N_1}{N_2} = \frac{D_2}{D_1} = \frac{T_2}{T_1}$$

Here, subscripts 1 and 2 are used for driving and driven gears, respectively.

*Addendum Circle:* It is a circle passing through the tips of the teeth.

*Addendum:* It is the radial height of tooth above the pitch circle. Its standard value is one module.

*Dedendum Circle:* It is a circle passing through roots of the teeth.

*Dedendum:* It is a radial depth of a tooth below the pitch circle. Its standard value is 1.157 m.

*Full Depth of Teeth:* It is the total depth of the tooth space, i.e., Full depth = Addendum + Dedendum =  $(1 + 1.157) \times \text{module} = 2.157 \times \text{module}$ .

*Working Depth of Teeth:* The maximum depth at which a tooth penetrates into tooth space of the mating gear is known as working depth of teeth.

*Space Width:* It is the width of the space between two consecutive teeth on pitch circle.

*Tooth Thickness:* It is the thickness of the tooth measured along the pitch circle.

*Backlash:* It is the difference between the space width and the tooth thickness along the pitch circle.

*Face Width:* It is the length of tooth parallel to the gear axis.

*Top Land:* It is the surface of the top of the tooth.

*Bottom Land:* The surface of the bottom of the tooth between the adjacent fillets.

*Face:* It is the tooth surface between the pitch circle and the top land.

*Flank:* It is the curved portion of the tooth flank at the root circle.

*Pressure Angle,  $\phi$ :* The angle between the pressure line and the common tangent at the pitch point is known as the pressure angle or angle of obliquity.

*Path of Contact or Contact Length:* Locus of the point of contact of teeth of two mating gears from the beginning of the engagement to the end of engagement is known as the path of contact or the contact length.

*Path of Approach:* Portion of the path of contact from the beginning of the engagement to the pitch point is known as the path of approach.

*Path of Recess:* Portion of the path of contact from the pitch point to the end of engagement is known as the path of the recess.

*Arc of Contact:* Locus of points on the pitch circle from the beginning of the engagement to the end of engagement of two mating gears is known as the arc of contact.

*Arc of Approach:* It is the portion of the arc of contact from the beginning of the engagement to the pitch point of two mating gears is known as the arc of contact.

*Arc of Recess:* It is the portion of the arc of contact from the pitch point to the end of engagement to of two mating gears is known as the arc of the recess.

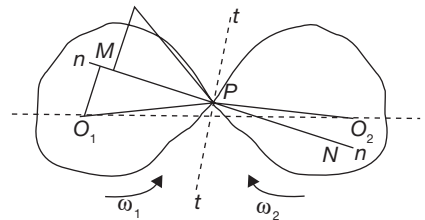
*Contact Ratio:* It is the ratio of the length of the arc of contact to circular pitch.

$$\text{Contact ratio (Number of pair of teeth in contact)} = \frac{\text{Length of arc of contact}}{\text{Pitch}}$$

### 15.5.2 Law of Gearing

The law of gearing gives the condition for the tooth profiles for constant angular velocity for two mating gears, which can be explained as: “If angular velocities of two mating gears remain constant, the common normal at the point of the two teeth should always pass through a fixed point P which divides the line joining the centers in the inverse ratio of angular velocities of the gears”. In Figure 15.17,

$$\frac{\omega_1}{\omega_2} = \frac{O_2N}{O_1M} = \frac{O_2P}{O_1P}$$



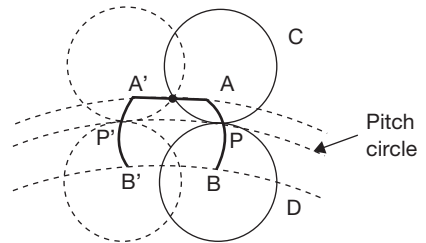
**FIGURE 15.17**  
Two Teeth in Meshing

### 15.5.3 Forms of Teeth

There are mainly two forms of gear teeth: (i) Cycloidal profile teeth, and (ii) Involute profile teeth.

#### Cycloidal Profile Teeth

A cycloid is the locus of points on the circumference of a circle that rolls without slipping on a fixed straight line. An epicycloid is the locus of points on the circumference of a circle that rolls without slipping outside the circumference of another circle. A hypocycloid is the locus of points on the circumference of a circle that rolls without slipping inside the circumference of another circle. The construction of cycloidal teeth is shown in Figure 15.18.



**FIGURE 15.18**

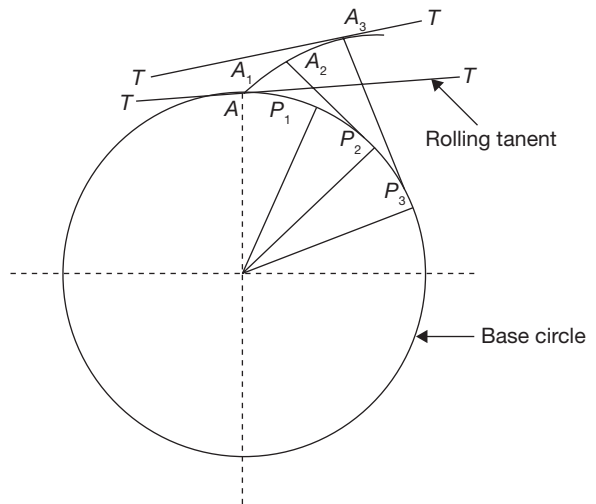
Cycloidal Profile of Gear Teeth

#### Advantages of Cycloidal Gears

- (i) Due to wider flank, cycloidal gear is stronger than involute gear for the same pitch.
- (ii) Less wear occurs in cycloidal teeth.
- (iii) There is no phenomenon of interference.

#### Involute Profile Tooth

An involutes profile is a plane curve generated by the points on tangent on a circle which rolls without slipping or by points on a taught string which is unwrapped from a reel as shown in Figure 15.19.



**FIGURE 15.19**

Involute Profile of Gear

#### Advantages of Involute Gears

- (i) Center distance can be varied within limit without a change in pressure angle which is not possible in cycloidal gears.
- (ii) Pressure angle remains constant throughout the engagement but in the case of cycloidal gears, pressure angle is maximum at the beginning and end of engagement and minimum at the pitch point.
- (iii) The face and flank of involute teeth are generated by a single curve wherein cycloidal gears, epicycloids, and hypo-cycloid are required for face and flank, respectively. Thus, involute teeth are easy to manufacture than the cycloidal gear.

## 15.6 ► CLASSIFICATION OF GEARS

Gears can be classified according to the position of shafts as:

### 15.6.1 Parallel Shafts

#### *Spur Gears*

**General:** Spur gears are the most commonly used gear. They are characterized by teeth which are parallel to the axis. The basic descriptive geometry for a spur gear is shown in Figure 15.20.

**Advantages:** Spur gears are easy to find, inexpensive, and efficient.

**Limitations:** Spur gears generally cannot be used when a direction change between the two shafts is required. Also, this type of gear is used for smaller speed due to noise creation at high-speed power transmission.

#### *Helical Gears*

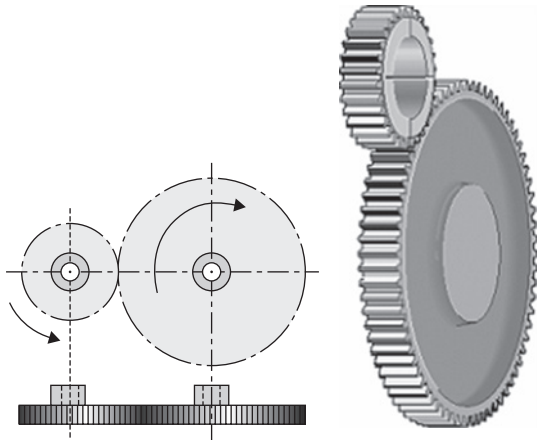
Helical gears are similar to the spur gear except that the teeth are at an angle to the shaft, rather than parallel to its axis as in a spur gear. The resulting teeth are longer than the teeth on a spur gear of equivalent pitch diameter. The longer teeth cause helical gears to have the following differences from spur gears of the same size:

- (i) Tooth strength is greater because the teeth are longer.
- (ii) Greater surface contact on the teeth allows a helical gear to carry more load than a spur gear.
- (iii) The longer surface of contact reduces the efficiency of a helical gear relative to a spur gear.

Helical gears may be used to mesh two shafts that are not parallel, although they are still primarily used in parallel shaft applications. A special application in which helical gears are used is a crossed gear mesh, in which the two shafts are perpendicular to each other. The basic geometry for a helical gear is shown in Figure 15.21.

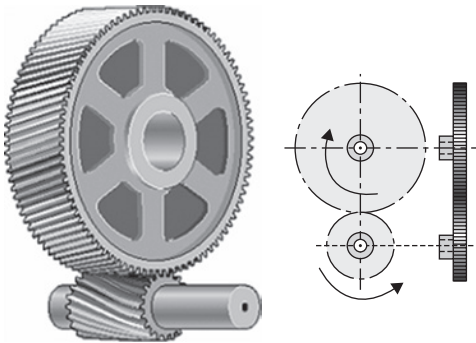
**Advantages:** Helical gears can be used on non-parallel and even perpendicular shafts, and can carry higher loads than can spur gears.

**Limitations:** Helical gears are expensive and much more difficult to manufacture. They are also slightly less efficient than a spur gear of the same size.

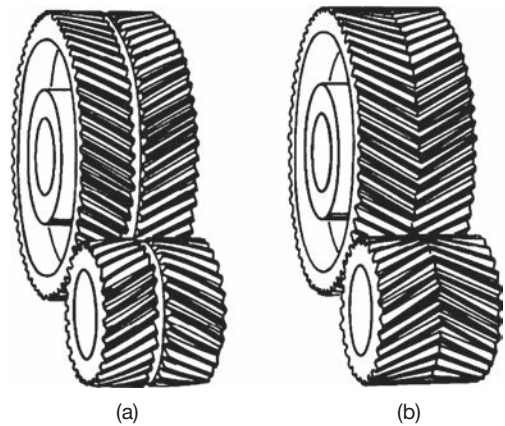


**FIGURE 15.20**

Spur Gear

**FIGURE 15.21**

Helical Gear

**FIGURE 15.22**

(a) Double Helical Gearing with Two Pairs of Opposed Gears, (b) Herringbone Gears having Opposed Teeth Joined in the Middle.

### Double Helical / Herringbone Gears

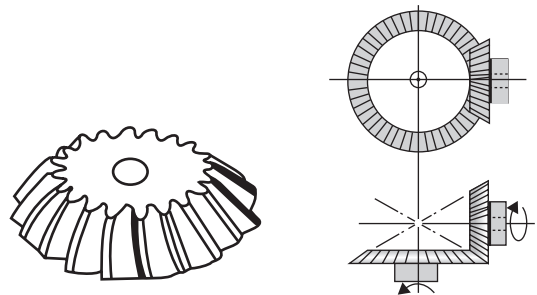
Double helical gears have one a right-hand helix and the other a left-hand helix. The teeth of two rows are separated by a groove used for tool run out. Axial thrust, which occurs in the case of single helical gears, two rows of teeth cancel each other. This can be run at high speeds with less noise and vibrations. Figure 15.22 shows the basic structure of double helical gear and herringbone or double helical gear.

Herringbone gears have opposed teeth to eliminate side thrust loads the same as double helical, but they are joined in the middle of the gear circumference. This arrangement makes herringbone gears more compact than double-helical. However, the gear centers must be precisely aligned to avoid interference between the mating helices.

## 15.6.2 Intersecting Shaft

### Bevel Gears

Bevel gears are primarily used to transfer power between intersecting shafts. The teeth of these gears are formed on a conical surface. Standard bevel gears have teeth which are cut straight and are all parallel to the line pointing the apex of the cone on which the teeth are based as shown in Figure 15.23. Spiral bevel gears are

**FIGURE 15.23**

Bevel Gears

also available which teeth form arcs. Hypocycloid bevel gears are a special type of spiral gear that will allow non-intersecting, non-parallel shafts to mesh. Straight tool bevel gears are generally considered the best choice for systems with lower speeds. They become noisy above this point. One of the most common applications of bevel gears is the differential in automobiles.

**Advantages:** It is an excellent choice for intersecting shaft systems.

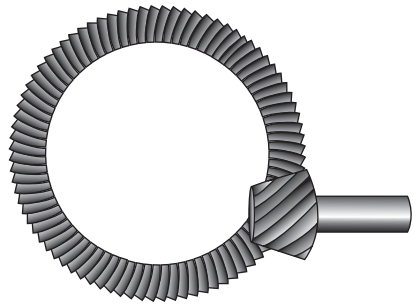
**Limitations:** It cannot be used for parallel shafts and becomes noisy at high speeds.

### Hypoid Gears

Hypoid gears resemble spiral bevels, but the axes of the pinion shaft and gear shaft do not intersect (Figure 15.24). This configuration allows both shafts to be supported at both ends. In hypoid gears, the meshing point of the pinion with the driven gear is about midway between the central position of a pinion in a spiral-bevel and the extreme top or bottom position of a worm. This geometry allows the driving and driven shafts to continue past each other so that end support bearings can be mounted. These bearings provide greater rigidity than the support provided by the cantilever mounting used in some bevel gearing.

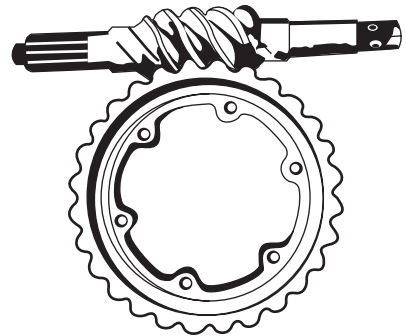
### Worm Gears

If a tooth of a helical gear makes complete revolutions on the pitch cylinder, the resulting gear is known as a worm. The mating gear is called worm wheel as shown in Figure 15.25. The worm may be a single start, double start, or triple start.



**FIGURE 15.24**

Hypoid Gear



**FIGURE 15.25**

Worm Gear



## RECAP ZONE .....

### Points to Remember

- **Power transmission** is a process to transmit motion from one shaft to another by using some connection between them like belt, rope, chain, and gears.
- Belt, rope, and chain are flexible connectors where gears are rigid connectors.
- In **belt drive**, the velocity of two shafts can be varied by variation of diameter of the pulley on which belt is mounted.
- In **chain or gear drive**, the velocity of two shafts is varied by variation in the number of teeth on sprocket and gear, respectively.
- The effect of **slip** is a decrease in the speed of belt on driving shaft and the driven shaft.
- When belt passes from slack to tight side, a certain portion of belt extends and again contracts when belt passes through tight to slack side. Due to fluctuation in length of the belt, there is relative motion between belt and pulley surface. This relative motion is known as creep.
- The **open-belt drive** is used to provide the same direction of rotation to the driven shaft as the direction of rotation of the driving shaft.
- The **cross-belt drive** is used to provide reverse direction of rotation to the driven shaft as the direction of rotation of the driving shaft.
- When the velocity of the belt is more than 10 m/sec, the centrifugal force due to self-weight of the belt becomes predominant.
- To overcome the problem of slip in belt drive or rope drive, chain drive is used.
- **Gears** are compact power transmission device that controls the speed, torque, and direction of rotation of the driven shaft.
- The point of contact between pitch circles of two gears is known as **pitch point**.
- The circle passing through the point of contacts of two gears is known as **pitch circle**.
- The diameter of pitch circle is known as **pitch diameter**.
- **Circular Pitch** is the distance measured along the circumference of the pitch circle from a Point on one tooth of the corresponding point on the adjacent tooth.
- **Dimetral Pitch** is the number of teeth per unit length of the pitch circle diameter.
- **Module** is the ratio of pitch diameter to the number of teeth.
- **Gear ratio** is the ratio of a number of teeth on gear and pinion.
- **Velocity ratio** is ratio of angular velocity of the driving gear to driven gear.
- **Addendum circle** is a circle passing through the tips of the teeth.
- **Addendum** is the radial height of tooth above the pitch circle. Its standard value is one module.
- **Dedendum circle** is a circle passing through roots of the teeth.
- **Face** is the tooth surface between the pitch circle and the top land.
- **Flank** is the curved portion of the tooth flank at the root circle.
- The angle between the pressure line and the common tangent at the pitch point is known as the pressure angle or **angle of obliquity**.



- **Law of gearing:** If angular velocities of two mating gears remain constant, the common normal at the point of the two teeth should always pass through a fixed point P which divides the line joining the centers in the inverse ratio of angular velocities of the gears.
- A **cycloid** is the locus of points on the circumference of a circle that rolls without slipping on a fixed straight line.
- An **epicycloid** is the locus of points on the circumference of a circle that rolls without slipping outside the circumference of another circle.
- A **hypocycloid** is the locus of points on the circumference of a circle that rolls without slipping inside the circumference of another circle.
- An **involute profile** is a plane curve generated by the points on a tangent on a circle which rolls without slipping or by points on a taut string which is unwrapped from a reel.
- **Spur gears** are the most commonly used gear. They are characterized by teeth which are parallel to the axis.
- **Helical gears** are similar to the spur gear except that the teeth are at an angle to the shaft, rather than parallel to its axis as in a spur gear.
- **Double helical gears** have one a right-hand helix and the other a left-hand helix.
- **Bevel gears** are primarily used to transfer power between intersecting shafts. The teeth of these gears are formed on a conical surface.
- **Hypoid gears** resemble spiral bevels, but the axes of the pinion shaft and gear shaft do not intersect.
- If a tooth of a helical gear makes complete revolutions on the pitch cylinder, the resulting gear is known as a worm. The mating gear is called **worm wheel**.

## Important Formulae

1. Belt drive:

$$(a) \quad V.R = \frac{N_2}{N_1} = \frac{D_1}{D_2}$$

$$(b) \quad S = S_1 + S_2 - 0.01S_1S_2$$

$$\text{velocity ratio, } V.R = \frac{D_1}{D_2} \left( \frac{100-S}{100} \right) = \frac{N_2}{N_1}$$

$$(c) \quad \text{Creep: } \frac{N_2}{N_1} = \frac{D_1}{D_2} \times \frac{E + \sqrt{\sigma_2}}{E + \sqrt{\sigma_1}}$$

$$(d) \quad \text{Length of belt in open belt drive: } L = (R+r) + C + \frac{(R-r)^2}{C}$$

$$(e) \quad \text{Length of belt in cross belt drive: } L = \pi(R+r) + 2C + \frac{(R+r)^2}{C}$$

(f) Ratio of tensions

$$\frac{T_1}{T_2} = e^{\mu\theta} \quad \text{For flat belt}$$

$$\frac{T_1}{T_2} = e^{\mu\theta/\sin\alpha} \quad \text{For } V\text{-belt} \quad \text{Where } \alpha \text{ is the angle made by } V\text{-section of the belt}$$

$$(g) \quad \text{Effect of centrifugal tension in belt drive: Power, } P = bt \left( \sigma - \rho V^2 \right) \left( \frac{e^{\mu\theta} - 1}{e^{\mu\theta}} \right) \times V$$

$$(h) \quad \text{Conditions for max. power transmission: } V = \sqrt{\frac{\sigma}{3\rho}} = \sqrt{\frac{T}{3m}}$$

2. Radius of pitch circle in chain drive:  $r = \frac{p}{2} \operatorname{cosec} \frac{180^\circ}{T}$

3. Length of chain:  $L = p \left[ \frac{(T+t)}{2} + \frac{\left( \operatorname{Cosec} \frac{180^\circ}{T} - \operatorname{Cosec} \frac{180^\circ}{t} \right)}{4k} + 2k \right]$

4. Gear drive

(a) Diametral pitch  $P_d = \frac{T}{D}$

(b) Module,  $m = \frac{D}{T} = \frac{1}{P_d} = \frac{P_c}{\pi}$

(c) Gear ratio,  $G = \frac{T}{t}$

(d) Velocity ratio,  $VR = \frac{\omega_1}{\omega_2} = \frac{N_2}{N_1} = \frac{D_2}{D_1} = \frac{T_2}{T_1}$

(e) Contact ratio (Number of pair of teeth in contact) =  $\frac{\text{Length of arc of contact}}{\text{Pitch}}$

## REVIEW ZONE



### Multiple-choice Questions

- In a belt drive pulley acts as:
  - Sliding pair
  - Rolling pair
  - Turning pair
  - None of these
- When two pulleys are connected by a cross-belt drive, then both the pulleys rotate in:
  - Same direction
  - Opposite direction
  - Not necessary
  - None of these
- Length of open belt connecting two pulleys of radii  $r_1$  and  $r_2$  and at a center distance  $D$  apart, is:
  - $\pi(r_1 + r_2) + (r_1 - r_2)^2/D + 2D$
  - $\pi(r_1 + r_2) + (r_1 + r_2)^2/D + 2D$
  - $\pi(r_1 - r_2) + (r_1 + r_2)^2/D + 2D$
  - $\pi(r_1 + r_2) + (r_1 - r_2)^2/D + 2D$
- Length of cross belt connecting two pulleys of radii  $r_1$  and  $r_2$  and at a center distance  $D$  apart, is:
  - $\pi(r_1 + r_2) + (r_1 - r_2)^2/D + 2D$
  - $\pi(r_1 + r_2) + (r_1 + r_2)^2/D + 2D$
  - $\pi(r_1 - r_2) + (r_1 + r_2)^2/D + 2D$
  - $\pi(r_1 + r_2) + (r_1 - r_2)^2/D + 2D$
- Angle of contact in cross-belt drive in comparison to open belt drive is:
  - More
  - Less
  - Same
  - None
- Slip in belt drive is difference between:
  - Angular velocities between two pulleys
  - The linear speed of the rim of pulleys and the belt on it
  - The velocities of two pulleys
  - None of these
- In belt drives, effect of centrifugal tension is:
  - To increase the driving power
  - To decrease the driving power
  - Nor appreciable on driving power
  - None of these
- If  $T_1$  and  $T_2$  are tensions on tight and slack side of belt,  $\theta$  is angle of contact and  $\mu$  is coefficient of friction between belt and pulley, then ratio of tension is:
  - $T_1/T_2 = \mu^\theta$
  - $T_1/T_2 = e^{\mu\theta}$
  - $T_1/T_2 = e^{\mu\theta}$
  - $T_1/T_2 = e^{1/\mu\theta}$
- For maximum power transmission, the maximum tension  $T_{\max}$  in the belt is equal to:
  - $T_c$
  - $2T_c$
  - $3T_c$
  - $T_c/3$
- Creep in belt is due to:
  - The elasticity of belt material
  - Elongation of the belt due to tension

- (c) Differential elongation of the belt due to the difference in tension on two sides of a pulley  
 (d) Plasticity of belt material
11. Included angle of V-belt is generally:  
 (a)  $10^\circ$  to  $20^\circ$  (b)  $20^\circ$  to  $30^\circ$   
 (c)  $30^\circ$  to  $40^\circ$  (d)  $50^\circ$  to  $60^\circ$
12. In designation 6 by 19 rope, 6 and 19 respectively stand for:  
 (a) The diameter of wire rope and number of strands  
 (b) The diameter of wire rope and number of wires  
 (c) Number of wires and number of strands  
 (d) Number of strands and number of wires
13. A chain drive is used for:  
 (a) Short distance (b) Medium distance  
 (c) Long distance (d) Distance is no barrier
14. Silent chain is made of:  
 (a) Links and blocks  
 (b) Links, pins, bushings, and rollers  
 (c) 3 or more roller chains  
 (d) Inverted tooth and overlapping links
15. Wire ropes are used for:  
 (a) Low speeds and low tension  
 (b) Low speeds and high tension  
 (c) High speeds and low tension  
 (d) None of these
16. The ratio of the number of teeth and pitch circle diameter is called:  
 (a) Pitch (b) Circular pitch  
 (c) Diametral pitch (d) Module
17. The circle passing through the bottom of the teeth of gear is known as:  
 (a) Inner circle (b) Base circle  
 (c) Addendum Circle (d) Dedendum circle
18. The circle passing through the top of the teeth of gear is known as:  
 (a) Inner circle (b) Base circle  
 (c) Addendum circle (d) Dedendum circle
19. Pitch circle diameter of an involute gear is:  
 (a) Independent of any other factor  
 (b) Dependent on the pressure angle  
 (c) Constant for a set of meshing gears  
 (d) Proportional to the base diameter
20. The surface of the gear below the pitch circle is called:  
 (a) Face (b) Flank  
 (c) Bottom tooth (d) Tooth depth
21. Law of the gearing is satisfied if  
 (a) Two surfaces slide smoothly  
 (b) Common normal at the point of contact passes through pitch point on the line joining the centers of rotation  
 (c) The addendum is greater than dedendum  
 (d) None of these

### Fill in the Blanks

22. The slippage does not occur in the belt drive of \_\_\_\_\_ cross-section.
23. The difference between dedendum and addendum is known as \_\_\_\_\_.
24. Best profile to obtain resistance against wear is \_\_\_\_\_.
25. The product of circular pitch and diametral pitch is equal to \_\_\_\_\_.

### Answers

- |   |           |         |             |               |         |
|---|-----------|---------|-------------|---------------|---------|
| 1. (b)  | 2. (b)    | 3. (a)  | 4. (b)      | 5. (a)        | 6. (b)  |
| 7. (c)  | 8. (b)    | 9. (c)  | 10. (c)     | 11. (c)       | 12. (d) |
| 13. (a)                                       | 14. (d)   | 15. (b) | 16. (c)     | 17. (d)       | 18. (c) |
| 19. (b)                                       | 20. (b)   | 21. (b) | 22. toothed | 23. clearance |         |
| 24. $14\frac{1}{2}^\circ$ full depth involute | 25. $\Pi$ |         |             |               |         |

## Theory Questions

1. In a flat belt drive prove that

$$\frac{T_1}{T_2} = e^{\mu\theta}, \text{ where } T_1 \text{ is tension in tight}$$

side,  $T_2$  is tension in slackside,

$\mu$  is coefficient of friction,  $\theta$  is angle of lap in radian.

2. What is initial tension in the belt? Explain the effect of centrifugal tension in the belt drive.
3. Find the condition for maximum power transmission in the belt drive.
4. Find the expression for the length of belt in the open belt drive.
5. Find the expression for the length of belt in the cross belt drive.
6. What are the various types of chain drive? Explain with neat sketches.
7. What are the relative merits and demerits of belt, rope and chain drive?
8. State the law of gearing.
9. Define: (i) module, (ii) pressure angle, (iii) pitch point, (iv) addendum, (v) dedendum, (vi) flank, (vii) face, (viii) circular pitch, (ix) dimetral pitch, and (x) pitch circle.
10. Differentiate involute and cycloidal profiles of gear teeth.
11. Classify the gears and explain them with neat sketches.
12. Explain the phenomena interference and undercutting in gear drive.
- \*13. Sketch and describe helical and bevel gear and state applications of each.
- \*14. What is belt drive? Describe briefly types of belt drives.
- \*15. Explain with a neat sketch worm and worm wheel.
- \*16. Write the different methods of power transmission?
- \*17. Explain chain drives and rope drives, and their applications?
- \*18. Explain belt drives and types of belts used in belt drives?
- \*19. Enumerate the advantages and disadvantages of gear drives.
- \*20. Derive an equation for the ratio of tension in the belt drive.
- \*21. Define slip and creep with respect to belt drives.

## Numerical Problems

1. The speed of a driving shaft is 80 rpm and the speed of the driven shaft is 120 rpm. The diameter of the driving pulley is given as 600 mm. Find the diameter of the driven pulley in the following cases:
- If belt thickness is negligible
  - If belt thickness is 5 mm
  - If total slip is 10% (considering thickness of belt)
  - If a slip of 2% on each pulley (considering thickness of belt)
2. Two shafts are arranged parallel to each other at a distance of 8 m. If the pulleys' diameters mounted on the shafts are of 600 mm and 1000 mm. Find the ratio of the length of belts for open and cross belt drives.
3. A leather belt of density  $1000 \text{ kg/m}^3$ , the thickness of 10 mm is used to transmit a power of 10 kW from a pulley of diameter 1.2 m and running at 250 rpm. Determine the width of the belt taking centrifugal tension into account. If the angle of the lap is  $160^\circ$  and coefficient of friction between belt and pulley is 0.25. Assuming allowable stress for the leather belt is 1.5 MPa.
4. An open belt drive transmits a power of 5 kW. The linear velocity of the belt is 8 m/sec. The angle of the lap on the smaller pulley is  $165^\circ$ . The coefficient of friction between belt and pulley is 0.25. Determine the effect of the following on power transmission.
- Initial tension in the belt is increased by 5%.
  - The angle of the lap is increased by 5% using,

idler pulley for same speed and tension in the tight side.

- (c) The coefficient of friction is increased by 5%.
5. The gear 1, mounted on the motor shaft, rotates at 600 rpm. Find the speed of gear 6, mounted on the output shaft. The number of teeth on each gear are given below as (refer Figure 15.25):

Gear	1	2	3	4	5	6
Teeth	20	30	60	40	80	100

6. An engine turning 250 rev/min drives a 40 cm diameter shaft with the help of belt drive system. If the diameter of engine pulleys is 60 cm determine the speed of the shaft. How would the shaft

speed be attached if a belt thickness of 10 mm is accounted for?

7. A flat belt is required to transmit 35 kW from a pulley of 1.5 m effective diameter running at 300 rpm. The angle of contact is spread over  $11/24$  of the circumference and the coefficient of friction between belt and pulley is 0.3. The belt thickness is 9.5 mm and its density is  $1\ 100\ \text{kg/m}^3$ . If the permissible stress in the belt is  $2.5\ \text{N/mm}^2$ , determine the width of belt required.
8. A V-belt drive transmits 10 kW power at 240 rpm. The grooved pulley has a mean diameter of 1.2 m and groove angle of  $45^\circ$ . Taking  $\mu = 0.3$  and angle of lap equal to radians, determine the tensions on each side of the belt.

## Learning Objectives

*By the end of this chapter, the student will be able:*

- To design and demonstrate the application of couplings
- To design and demonstrate the different types of clutches and their applications
- To design and demonstrate the different types of braking systems and their applications

## COUPLINGS

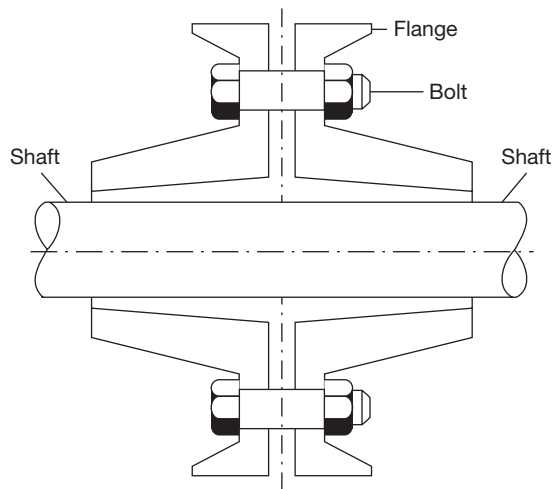
### 16.1 ► INTRODUCTION

The term coupling is a device used to connect two shafts together at their ends for transmitting the power. There are a number of coupling devices used to couple two shafts but in this chapter, only a few important couplings have been introduced for an understanding of the students. There are two general types of couplings: (i) rigid, and (ii) flexible.

### 16.2 ► RIGID COUPLING

Rigid couplings are designed to draw two shafts together tightly so that no relative motion can occur between them. This design is used for some special kinds of equipment in which precise alignment of two shafts is required. In such cases, the coupling must be capable of transmitting the torque in the shafts. Rigid couplings should be used only when the alignment of the two shafts can be maintained very accurately, not only at the time of installation but also during operation. If significant angular, radial or axial misalignment occurs, stresses that are difficult to predict and that may lead to early failure due to fatigue will be induced in the shafts. The load path is from the driving shaft to its flange, through the bolts, into the mating flange, and out to the driven shaft. The torque places the bolts in shear.

It consists of two cast iron flanges which are keyed to the shafts to be joined as shown in Figure 16.1. The flanges are brought together and are bolted in the annular space between the hub and the projecting flange. The protective flange is provided to guard the projecting bolt heads and nuts. The bolts are placed equispaced on a bolt circle diameter and the number of bolts depends on the shaft diameter  $d$ .



**FIGURE 16.1**  
Rigid Flange Coupling

### Advantages of Rigid Flange Coupling

- (i) It has high torque transmission capacity.
- (ii) It is easy to assemble and disassemble.
- (iii) It is a simple design and easy to manufacture.

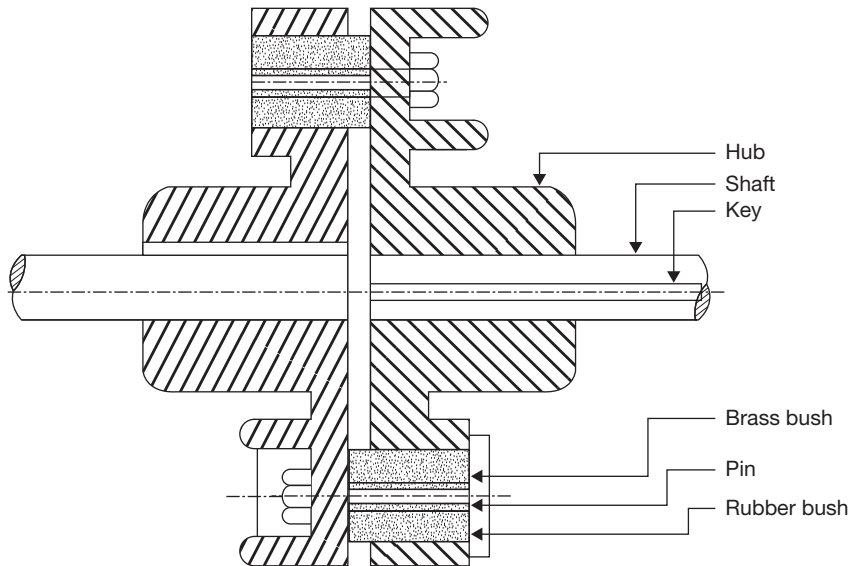
### Disadvantages of Rigid Flange Coupling

- (i) It cannot tolerate misalignment between two shafts.
- (ii) It can be used only where the motion is free from shocks and vibrations.
- (iii) It requires more space than that of another coupling like muff coupling.

## 16.3 ► FLEXIBLE BUSHED COUPLING

In a rigid coupling, the torque is transmitted from one-half of the coupling to the other through the bolts and in this arrangement, shafts need be aligned very well. However, in the bushed coupling, the rubber bushings over the pins (bolts) (as shown in Figure 16.2)

provide flexibility and these coupling can accommodate some misalignment. Because of the rubber bushing, the design for pins should be considered carefully.



**FIGURE 16.2**

Flexible Bushed Coupling

### Advantages of Flexible Bushed Coupling

- (i) It can bear 0.5 mm of lateral or axial misalignment and  $1.5^\circ$  of angular misalignment.
- (ii) It prevents transmission of shock from one shaft to the other and absorbs vibrations.
- (iii) It is used for transmission of high torque.
- (iv) It is easy to assemble and disassemble due to the simple design.

### Disadvantages of Flexible Bushed Coupling

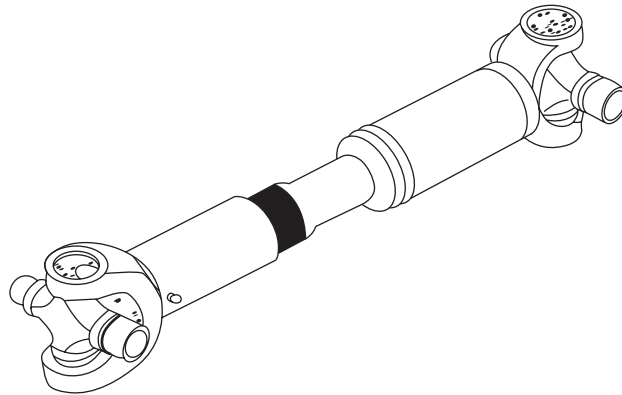
- (i) Its cost is higher than the rigid flange coupling.
- (ii) It requires more radial space.

## 16.4 ► UNIVERSAL JOINT

To accommodate misalignment between mating shafts for more than the  $3^\circ$ , a universal joint is used. Angular misalignments of up to  $45^\circ$  are possible at low rotational speeds with single universal joints. It consists of two yokes, a center bearing block, and two pins that pass



through the block at right angles. Approximately 20 to 30° is more reasonable for speeds about 10 rpm. Since universal joints have the disadvantage that the rotational speed of the output shaft is non-uniform in relation to the input shaft. A double universal joint allows the connected shafts to be parallel and offset by large amounts as shown in Figure 16.3. Furthermore, the second joint cancels the non-uniform oscillation of the first joint so the input and the output rotate at the same speed.



**FIGURE 16.3**  
Universal Joint

## CLUTCHES

### 16.5 ► INTRODUCTION

Clutch is a device which is used to engage and disengage the driven shaft from driving shaft during the motion to change the gears meshing without stopping the driving shaft. Its operation is based on the friction between two surfaces; friction torque is applied by the driving shaft on the driven shaft.

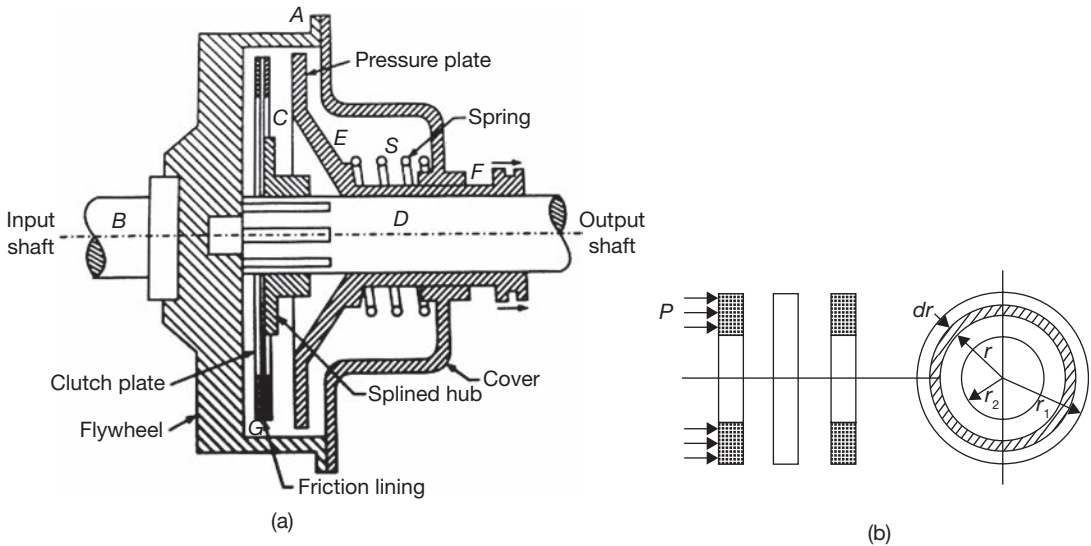
Clutch may be classified as:

1. Single plate clutch or disc clutch.
2. Multi-plate disc clutch.
3. Conical clutch.
4. Centrifugal clutch.

### 16.6 ► SINGLE PLATE CLUTCH

In a single plate clutch, a flywheel 'A' is bolted to a flange on the driving shaft B. The friction plate C is fixed to a hub which can slide on the spline i.e., driven shaft 'D'. Two rings

of friction material are riveted to flange 'A' and the plate 'C'. The pressure plate 'E' is bushed internally, so as to revolve freely on shaft D and is integrated with withdrawal force F. A number of spiral springs are arranged around the clutch at 'S' as shown in Figure 16.4 (a), which provides axial thrust between friction surfaces.



**FIGURE 16.4**

(a) Single Plate Clutch (b) Friction Plate

When the withdrawal force is removed, the spring forces the pressure plate 'E' against the ring 'G'. The friction between the contact surfaces of rings 'G' and plate 'C' transmits a torque on 'D' and driven shaft starts to rotate.

Let  $W$  = axial load on the plate

$T$  = torque transmitted by clutch

$P$  = axial pressure intensity

$r_1$  and  $r_2$  = external and internal radii of friction plate

$\mu$  = coefficient of friction

Axial force on a small elemental ring of radius  $r$  and width  $dr$ ,  $\delta W = P \times 2\pi r dr$

Frictional force,  $F_r = \mu \delta W = \mu \times P \times 2\pi r dr$

Torque,  $\delta T = F_r \times r = \mu \times P \times 2\pi r dr \times r = \mu P 2\pi r^2 dr$

Now, there are two conditions: (i) Uniform pressure for new clutch plate, and (ii) uniform wear for old or worn clutch plate.

*Case I: Uniform Pressure*

$$P = \frac{W}{\pi(r_1^2 - r_2^2)} \text{ and } \delta T = 2\pi\mu Pr^2 dr$$

$$T = \int_{r_2}^{r_1} 2\pi\mu Pr^2 dr = 2\pi\mu P \left[ \frac{r^3}{3} \right]_{r_2}^{r_1} = 2\pi\mu P \left[ \frac{r_1^3 - r_2^3}{3} \right]$$

Putting the value of  $P$ , we get

$$T = 2\pi\mu \times \frac{W}{\pi(r_1^2 - r_2^2)} \times \left[ \frac{r_1^3 - r_2^3}{3} \right] = \frac{2}{3} \mu W \left[ \frac{r_1^3 - r_2^3}{r_1^2 - r_2^2} \right] = \mu WR$$

where  $R$  is mean radius and equals to  $\frac{2}{3} \left[ \frac{r_1^3 - r_2^3}{r_1^2 - r_2^2} \right]$

*Case II: Uniform Wear*

$$P \propto \frac{1}{r} \quad \text{or} \quad P \times r = \text{constant, } C$$

Normal force on the ring =  $P \times 2\pi r dr = \frac{C}{r} \times 2\pi r dr = 2\pi C dr$

Total force on the friction plate,  $W = \int_{r_2}^{r_1} 2\pi C dr = 2\pi C [r]_{r_2}^{r_1} = 2\pi C (r_1 - r_2)$

or

$$C = \frac{W}{2\pi(r_1 - r_2)}$$

$$\delta T = 2\pi\mu Pr^2 dr = 2\pi\mu \left( \frac{C}{r} \right) r^2 dr = 2\pi\mu C r dr$$

$$T = \int_{r_2}^{r_1} 2\pi\mu C r dr = 2\pi\mu C \left[ \frac{r^2}{2} \right]_{r_2}^{r_1} = 2\pi\mu C \left[ \frac{r_1^2 - r_2^2}{2} \right]$$

Putting the value of  $C$ , we get

$$T = 2\pi\mu \times \frac{W}{2\pi(r_1 - r_2)} \times \left[ \frac{r_1^2 - r_2^2}{2} \right] = \frac{1}{2} \mu W (r_1 + r_2) = \mu WR$$

where  $R$  is mean radius and equals to  $\frac{1}{2}(r_1 + r_2)$

**EXAMPLE 16.1**

A single plate disc clutch, both sides effective, has outer and inner radii as 250 mm and 150 mm. The maximum intensity of pressure at any point in the contact surface is not to exceed 0.1 N/mm<sup>2</sup>. If the coefficient of friction is 0.25, find the power transmitted by the clutch at a speed of 3,000 rpm: (i) assuming uniform wear, and (ii) assuming uniform pressure.

**SOLUTION**

(i) Considering uniform wear

$$W = P \times 2\pi r_2 (r_1 - r_2) = 0.1 \text{ N/mm}^2 \times 2\pi \times 150 \text{ mm} (250 \text{ mm} - 150 \text{ mm}) \\ = 9424.77 \text{ N}$$

$$\text{Mean radius, } R = \frac{r_1 + r_2}{2} = \frac{250 \text{ mm} + 150 \text{ mm}}{2} = 200 \text{ mm} = 0.2 \text{ m}$$

$$\text{Torque, } T = n \times \mu \times W \times R = 2 \times 0.25 \times 9424.77 \text{ N} \times 0.2 \text{ m} = 942.47 \text{ Nm.}$$

$$\text{Power, } P = T \times \omega = 942.47 \text{ Nm} \times 2\pi \times \frac{3000 \text{ rpm}}{60} = \mathbf{296.088 \text{ kW.}}$$

(ii) Considering uniform pressure

$$W = P \times \pi (r_1^2 - r_2^2) = 0.1 \text{ N/mm}^2 \times \pi ((250 \text{ mm})^2 - (150 \text{ mm})^2) = 12566.371 \text{ N}$$

$$\text{Mean radius, } R = \frac{2}{3} \left[ \frac{r_1^3 - r_2^3}{r_1^2 - r_2^2} \right] = \frac{2}{3} \left[ \frac{(250 \text{ mm})^3 - (150 \text{ mm})^3}{(250 \text{ mm})^2 - (150 \text{ mm})^2} \right] = 204.166 \text{ mm} = 0.204 \text{ m}$$

$$\text{Torque, } T = n \times \mu \times W \times R = 2 \times 0.25 \times 12566.371 \text{ N} \times 0.204 \text{ m} = 1282.871 \text{ Nm.}$$

$$\text{Power, } P = T \times \omega = 1282.871 \text{ Nm} \times 2\pi \times \frac{3000 \text{ rpm}}{60} = \mathbf{403.008 \text{ kW.}}$$

**EXAMPLE 16.2**

A single plate disc clutch has both of its sides effective, transmits power at 250 rpm. The coefficient of friction is 0.25. The outer and inner radii of the friction plate are 100 mm and 40 mm, respectively. Assuming uniform wear of the clutch, the maximum pressure intensity is 0.1 N/mm<sup>2</sup>. If the moment of inertia of the rotating part of the clutch is 8 kgm<sup>2</sup>, calculate the time to attain the full speed by the machine and the energy lost during slipping of the clutch.

Assuming uniform pressure, find the intensity of pressure and compare the power transmitted with uniform wear to that with uniform pressure.

**SOLUTION**

(i) Considering uniform wear

$$W = P \times 2\pi r_2 (r_1 - r_2) = 0.1 \text{ N/mm}^2 \times 2\pi \times 40 \text{ mm} (100 \text{ mm} - 40 \text{ mm}) = 1507.96 \text{ N}$$

$$\text{Mean radius, } R = \frac{r_1 + r_2}{2} = \frac{100 \text{ mm} + 40 \text{ mm}}{2} = 70 \text{ mm} = 0.07 \text{ m}$$

$$\text{Torque, } T = n \times \mu \times W \times R = 2 \times 0.25 \times 1507.96 \text{ N} \times 0.07 \text{ m} = 52.774 \text{ Nm.}$$

$$\text{Power} = T \times \omega = 52.774 \text{ Nm} \times 2\pi \times \frac{250 \text{ rpm}}{60} = 1381.724 \text{ kW.}$$

$$\text{Also, } T = I\alpha \Rightarrow \alpha = \frac{T}{I} = \frac{52.774 \text{ Nm}}{8 \text{ kgm}^2} = 6.59 \text{ rad/sec}^2$$

$$\alpha = \frac{\omega}{t} \Rightarrow t = \frac{\omega}{\alpha} = \frac{2\pi \times \frac{250 \text{ rpm}}{60}}{6.59 \text{ rad/sec}^2} = 4 \text{ sec.}$$

Energy loss during slipping period

$$\theta_1 = \omega \times t = \text{Angle turned by driving shaft in time } t.$$

$$\theta_2 = \frac{1}{2} \alpha^2 = \text{Angle turned by driven shaft in time } t.$$

$$\begin{aligned} \text{Energy lost} &= T(\theta_1 - \theta_2) = 52.774 \text{ Nm} \left( \frac{2\pi \times 250 \text{ rpm} \times 4 \text{ sec}}{60} - \frac{1}{2} \times 6.59 \text{ rad/sec}^2 \times (4 \text{ sec})^2 \right) \\ &= 2.744 \text{ kNm} \end{aligned}$$

(ii) With uniform pressure

$$P = \frac{W}{\pi(r_1^2 - r_2^2)} = \frac{1507.96 \text{ N}}{\pi((250 \text{ mm})^2 - (150 \text{ mm})^2)} = 0.0572 \text{ N/mm}^2$$

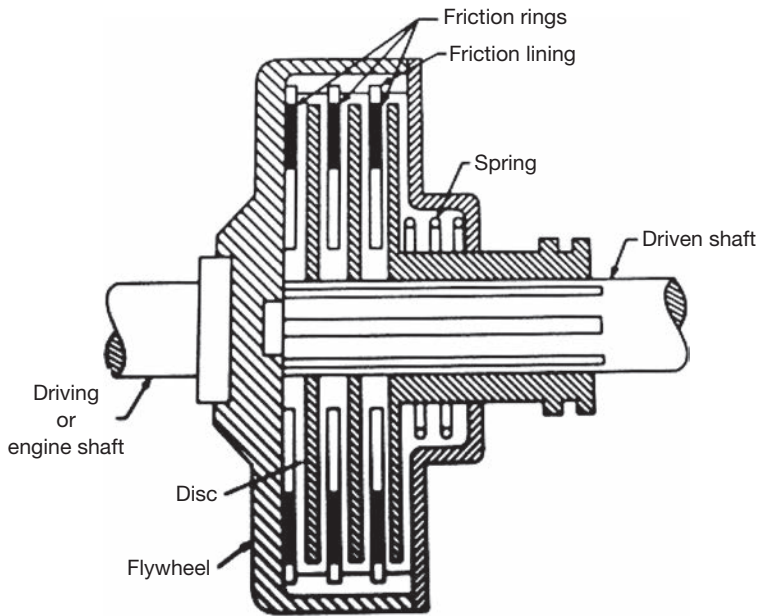
$$\text{Mean radius, } R = \frac{2}{3} \left[ \frac{r_1^3 - r_2^3}{r_1^2 - r_2^2} \right] = \frac{2}{3} \left[ \frac{(100 \text{ mm})^3 - (40 \text{ mm})^3}{(100 \text{ mm})^2 - (40 \text{ mm})^2} \right] = 74.285 \text{ mm} = 0.074 \text{ m}$$

$$\text{Torque, } T = n \times \mu \times W \times R = 2 \times 0.25 \times 1507.96 \text{ N} \times 0.074 \text{ m} = 56 \text{ Nm.}$$

$$\text{Power, } P = T \times \omega = 56 \text{ Nm} \times 2\pi \times \frac{250 \text{ rpm}}{60} = 1460 \text{ kW.}$$

## 16.7 ► MULTI-PLATE DISC CLUTCH

The function of multi-disc clutch is similar to the single plate clutch but the number of discs in the multi-disc clutch is more than one, i.e., 'n' as shown in Figure 16.5.



**FIGURE 16.5**

Multi-disc Clutch

### *Torque for Uniform Pressure*

$$T = n \times \frac{2}{3} \mu W \left[ \frac{r_1^3 - r_2^3}{r_1^2 - r_2^2} \right]$$

### *Torque for Uniform Wear*

$$T = n \times \frac{1}{2} \mu W (r_1 + r_2)$$

### EXAMPLE 16.3

A multi-disc clutch has 4-discs on the driving shaft and 3-discs on the driven shaft. The outside diameter of the contact surface is 240 mm and inside diameter 160 mm. Assuming uniform wear and coefficient of friction as 0.25, find the maximum axial intensity of pressure between the discs for transmission of 20 kW at 1,200 rpm.

## SOLUTION

$$n_1 = 4, n_2 = 3.$$

Number of pair of contact surfaces =  $n_1 + n_2 - 1 = 4 + 3 - 1 = 6$

$$\text{Power} = T \times \omega \Rightarrow T = \frac{\text{Power}}{\omega} = \frac{20 \times 10^3 \text{ W} \times 60}{2\pi \times 1200 \text{ rpm}} = 159.15 \text{ Nm}$$

Considering uniform wear

$$W = P \times 2\pi r_2 (r_1 - r_2)$$

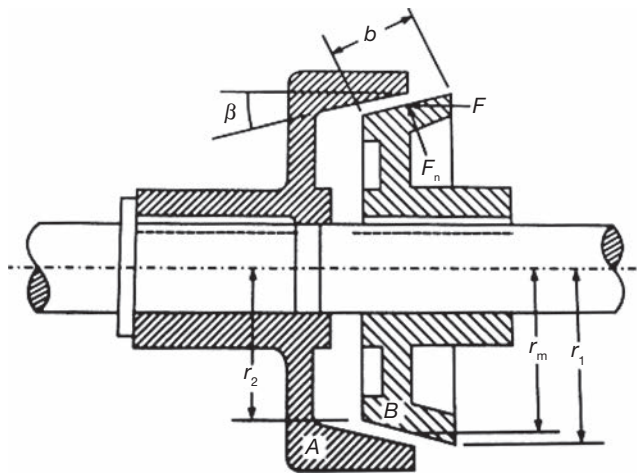
$$\text{Mean radius, } R = \frac{r_1 + r_2}{2} = \frac{120 \text{ rpm} + 80 \text{ rpm}}{2} = 100 \text{ mm} = 0.1 \text{ m}$$

$$\text{Torque, } T = n \times \mu \times W \times R = n \times \mu \times P \times 2\pi r_2 (r_1 - r_2) \times \left( \frac{r_1 + r_2}{2} \right)$$

$$P = \frac{T}{n \times \mu \times 2\pi r_2 (r_1 - r_2) \times \left( \frac{r_1 + r_2}{2} \right)}$$

$$= \frac{159.15 \text{ Nm}}{6 \times 0.25 \times 2\pi \times 0.080 \text{ m} (0.12 \text{ m} - 0.080 \text{ m}) \times 0.1 \text{ m}} = 52.77 \text{ N/m}^2$$

## 16.8 ► CONE CLUTCH



**FIGURE 16.6**

Cone Clutch

In cone clutch, the friction surfaces make a cone of an angle  $2\beta$  (Figure 16.6). The normal force on the cone is  $W_n = \frac{W}{\sin\beta}$  where  $\beta$  is the semi-cone angle. The main advantage of cone clutch is that the normal force is increased, since  $\sin\beta \leq 1$ .

### Torque for Uniform Pressure

$$T = \frac{2}{3} \mu W \left[ \frac{r_1^3 - r_2^3}{r_1^2 - r_2^2} \right] \operatorname{cosec} \beta$$

### Torque for Uniform Wear

$$T = \frac{1}{2} \mu W (r_1 + r_2) \operatorname{cosec} \beta$$

#### EXAMPLE 16.4

A cone clutch having a mean diameter of 200 mm and semi-cone angle of  $12.5^\circ$  transmits a torque of 200 Nm. The maximum normal pressure at the mean radius is  $0.1 \text{ N/mm}^2$ . The coefficient of friction is 0.25. Calculate the width of the contact surface. Also, find the axial force to engage the clutch.

#### SOLUTION

$$T = \mu \times F_a \times R_m \times \operatorname{cosec} \beta$$

$$F_a = \frac{T}{\mu \times R_m \times \operatorname{cosec} \beta} = \frac{200 \times \sin 12.5^\circ}{0.25 \times 200 \times 10^{-3} \text{ m}} = 865.7 \text{ N}$$

$$F_n = \frac{F_a}{\sin \beta} = \frac{865.7 \text{ N}}{\sin 12.5^\circ} = 3999.72 \text{ N}$$

$$\text{Also, } F_n = (2\pi \times R_m \times b) \times P$$

$$\text{or, } b = \frac{F_n}{(2\pi \times R_m) \times P} = \frac{3999.72 \text{ N}}{2 \times \pi \times 200 \times 10^{-3} \text{ m} \times 0.1 \times 10^6 \text{ N/m}^2} = 31.82 \text{ mm}$$

#### EXAMPLE 16.5

A cone clutch has a cone angle of  $30^\circ$ . The maximum pressure between contact surfaces is limited to  $0.25 \text{ N/mm}^2$  and width of the contact surface is half of the mean radius. Find the radii of the conical surface to transmit 20 kW at 1500 rpm assuming uniform wear condition. Coefficient of friction is 0.25.



## SOLUTION

$$b = \frac{R}{2}; \quad P = 0.25 \text{ N/mm}^2$$

$$\text{Power} = T \times \omega \Rightarrow T = \frac{\text{Power}}{\omega} = \frac{20 \times 10^3 \text{ W} \times 60}{2\pi \times 1500 \text{ rpm}} = 127.3 \text{ Nm.}$$

$$T = 127.3 \text{ Nm} = \mu \times (2\pi \times R_m \times P_n \times b \times \sin \alpha) \times R_m \times \text{cosec } \alpha$$

$$= 0.25 \times 2\pi \times R_m^2 \times 0.25 \times \frac{R_m}{2} = 0.196 R_m^3$$

$$R_m = \sqrt[3]{\frac{127.3 \text{ Nm}}{0.196}} = 0.086 \text{ m} = 86.6 \text{ mm.}$$

$$r_1 - r_2 = b \sin \alpha = \frac{R_m}{2} \sin \alpha = \frac{86.6 \text{ mm}}{2} \sin 12.5^\circ = 9.371 \text{ mm.} \quad (16.1)$$

$$r_1 + r_2 = 2R_m = 2 \times 86.6 \text{ mm} = 173.2 \text{ mm} \quad (16.2)$$

Solving Equations (16.1) and (16.2), we get

$$r_1 = 91.28 \text{ mm}$$

$$r_2 = 81.92 \text{ mm}$$

## 16.9 ► CENTRIFUGAL CLUTCH

Centrifugal clutch works on the principle of centrifugal force. When the driving shaft rotates at high speed, the shoes move radially outward. The outer surfaces of the shoes are covered with friction material which engages the pulley. Thus, pulley rotates with the driving shaft. The engagement of shoes with the pulley is shown in Figure 16.7. This type of clutch is generally used in motor pulley. The spring force resists the centrifugal force, thus prevents the engagement at a lower speed.

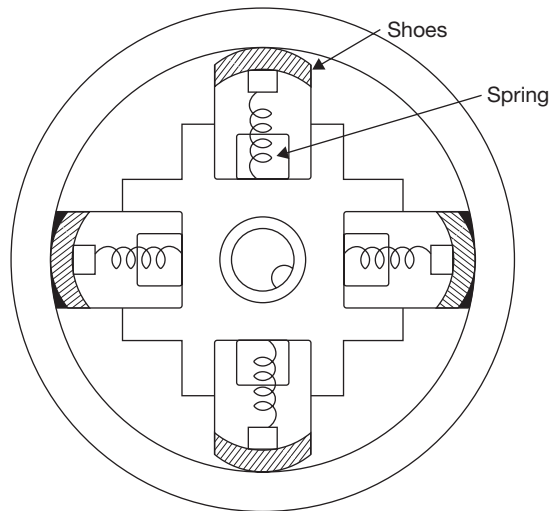
$$F_c = \text{centrifugal force} = m\omega^2 r$$

$$F_s = \text{Spring force} = m\omega_1^2 r$$

where  $\omega$  is the angular speed of the shaft.

$$\text{Torque, } T = F \times R = \mu n.(F_c - F_s).R$$

where  $n$  is a number of shoes.



**FIGURE 16.7**

Centrifugal Clutch

**EXAMPLE 16.6**

There are four shoes in a centrifugal clutch. The mass of each shoe is 10 kg and when the clutch is at rest, the force exerted by spring on the shoe is 400 N. The clearance between shoe and drum surface is 4 mm. Spring constant is 40 N/mm. The distance of the center of mass of shoe from the axis is 150 mm. The internal diameter of the drum is 320 mm. The coefficient of friction is 0.025; find the power transmitted by the clutch at 400 rpm.

**SOLUTION**

Operating radius,  $r_1 = 150 + 4 = 154 \text{ mm}$ .

Centrifugal force,  $F_c = m\omega^2 r_1 = 10 \times \left( \frac{2\pi \times 400 \text{ rpm}}{60} \right)^2 \times 0.154 \text{ m}$ ;

where  $\omega$  is the angular speed of the shaft.

Spring force,  $F_s = 400 \text{ N} + Kx = 400 \text{ N} + 40 \text{ N/mm} \times 4 \text{ mm} = 560 \text{ N}$

Tangential frictional force,  $F_t = \mu(F_c - F_s) = 0.25 \times (2702.07 \text{ N} - 560 \text{ N}) = 535.51 \text{ N}$

$$T = n \times F_t \times R = 4 \times 535.51 \text{ N} \times 0.16 \text{ m} = 342.73 \text{ Nm}.$$

Power transmission  $= T \times \omega = 342.73 \text{ Nm} \times \frac{2\pi \times 400 \text{ rpm}}{60} = 14.35 \text{ kW}$

**BRAKES****16.10 ► INTRODUCTION**

Brake is a device which is used to bring the body into rest while it is in motion or to hold a body in a state of rest by applying resisting force. There are four types of brakes as given below:

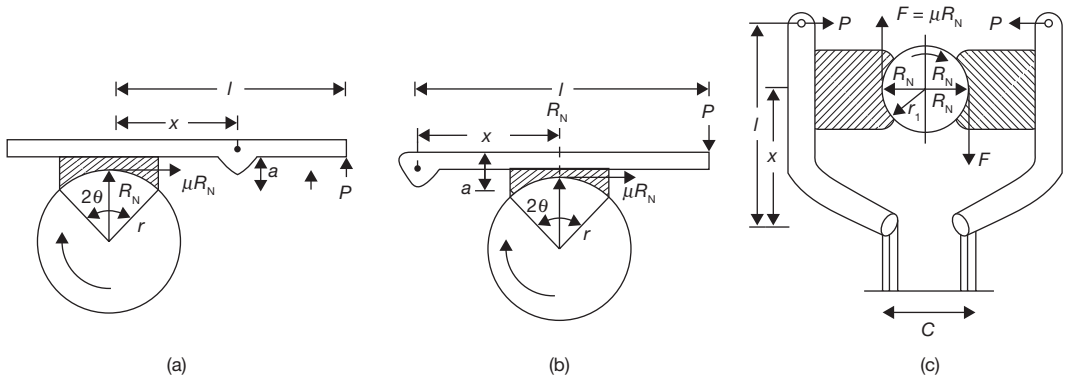
1. Block or shoe brake.
2. Band brake.
3. Band and block brake.
4. Internal expanding shoe brake.

**16.10.1 Block or Shoe Brake**

In this brake, a shoe or block is pressed against the drum. The force can be increased by using a lever as shown in Figure 16.8. The brake lining for friction is made of softer materials so that it can be replaced easily after wearing.

Let  $r = \text{radius of drum}$

$\mu = \text{Coefficient of friction}$



**FIGURE 16.8**

Block or Shoe Brakes

$R_N$  = Normal reaction on the shoes

$P$  = Force applied on lever

$F$  = Frictional force

In Figure 16.8 (a), taking moment about the pivot for clockwise rotation of drum

$$P \times (l - x) - R_N \times x + \mu \times R_N \times a = 0$$

or 
$$R_N = \frac{P(l - x)}{x - \mu a}$$

or 
$$R_N = \frac{P \times b}{x - \mu a} \quad \text{if } l - x = b$$

or 
$$P = \frac{R_N(x - \mu a)}{b}$$

For anticlockwise rotation of drum, 
$$P = \frac{R_N(x + \mu a)}{b}$$

In Figure 16.8 (b), taking moment about pivot for clockwise rotation of drum

$$P \times l - R_N \times x - \mu \times R_N \times a = 0$$

$$R_N = \frac{P \times l}{x + \mu a} \quad \text{or} \quad P = \frac{R_N(x + \mu a)}{l}$$

For anticlockwise rotation, 
$$R_N = \frac{P \times l}{x - \mu a} \quad \text{and} \quad P = \frac{R_N(x - \mu a)}{l}$$

Due to pressure applied by single shoe, there is a side thrust on the shaft of the drum. To counter balance the side thrust, two shoes may be used opposite to each other. In this case, braking torque becomes double which is shown in Figure 16.8 (c).

### EXAMPLE 16.7

A single block brake as shown in Figure 16.8 (b) has a diameter of brake drum 1.2 m. It can withstand 250 Nm torque at 500 rpm and coefficient of friction between block and drum is 0.3. Determine the force required to apply when the drum rotates in (a) clockwise direction and (b) anticlockwise direction. The angle of contact is  $2\theta = 30^\circ$  and  $x = 140$  mm,  $a = 30$  mm,  $l = 1000$  mm.

### SOLUTION

For clockwise rotation

$$P \times l - R_N \times x - \mu \times R_N \times a = 0$$

$$T = 250 \text{ Nm} = \mu \times R_N \times r \quad \text{or,} \quad R_N = \frac{T}{\mu \times r} = \frac{250 \text{ Nm}}{0.3 \times 1.2 \text{ m}} = 1388.88 \text{ N}$$

$$R_N = \frac{P \times l}{x + \mu a} \quad \text{or,} \quad P = \frac{R_N(x + \mu a)}{l} = \frac{1388.88 \text{ N} \times (0.14 \text{ m} + 0.3 \times 0.03 \text{ m})}{1}$$

$$= 206.94 \text{ N}$$

For anticlockwise rotation

$$R_N = \frac{P \times l}{x - \mu a} \quad \text{and} \quad P = \frac{R_N(x - \mu a)}{l} = \frac{1388.88 \text{ N} \times (0.14 \text{ m} - 0.3 \times 0.03 \text{ m})}{1}$$

$$= 182 \text{ N}$$

**Note:** If angle of contact ( $2\theta$ ) is reater than  $40^\circ$  use  $\mu'$  in place of  $\mu$ .

$$\mu' = \mu \left( \frac{4 \sin \theta}{2\theta + \sin 2\theta} \right)$$

### EXAMPLE 16.8

In a double block spring loaded brake as shown in Figure 16.8 (c) following dimensions have been given: drum diameter = 600 mm, angle of contact ( $2\theta$ ) =  $100^\circ$ , coefficient of friction ( $\mu$ ) = 0.3, force applied on the spring = 6 kN,  $x = 0.5$  m,  $l = 1$  m,  $c = 0.1$  m. Find the braking torque applied.

## SOLUTION

$$\mu' = \mu \left( \frac{4 \sin \theta}{2\theta + \sin 2\theta} \right) = 0.3 \left( \frac{4 \sin 50^\circ}{100^\circ \times \frac{\pi}{180^\circ} + \sin 100^\circ} \right) = 0.336$$

For left side block

Taking moment about  $o$ .

$$P \times l + F(d/2 - c/2) - R_{N1} \times x = 0$$

$$\text{or,} \quad 6000 \text{ N} \times 1 \text{ m} + 0.336 \times R_{N1} (0.3 \text{ m} - 0.05 \text{ m}) - R_{N1} \times 0.5 \text{ m} = 0$$

$$\text{or,} \quad R_{N1} = \frac{6000 \text{ N}}{0.416} = 14423.07 \text{ N}$$

For right side block

$$P \times l - \mu' \times R_{N2} (d/2 - c/2) + R_{N2} \times x = 0$$

$$\text{or,} \quad 6000 \text{ N} \times 1 \text{ m} - 0.336 \times R_{N2} (0.3 \text{ m} - 0.05 \text{ m}) + R_{N2} \times 0.5 \text{ m} = 0$$

$$\text{or,} \quad R_{N2} = 10273.973 \text{ N}$$

Maximum braking torque,  $T_B = \mu' (R_{N1} + R_{N2}) \times r$

$$= 0.336 \times (14423.07 \text{ N} + 10273.973 \text{ N}) \times 0.3 \text{ m} = 2489.461 \text{ Nm}$$

## 16.10.2 Band Brake

Band brake consists of a band in the form of belt, rope or steel band (Figure 16.9). When force is applied at the free end of the lever, the band is pressed against the external surface of the drum.

Braking torque,  $T = (T_1 - T_2) \times r$

But  $\frac{T_1}{T_2} = e^{\mu\theta}$ , where  $T_1$  is tension on tight side and  $T_2$  is tension in the slack side.

The effectiveness of braking force varies according to the direction of rotation of the drum, the ratio of length  $a$  and  $b$ , and the direction of force applied at the end of the lever.

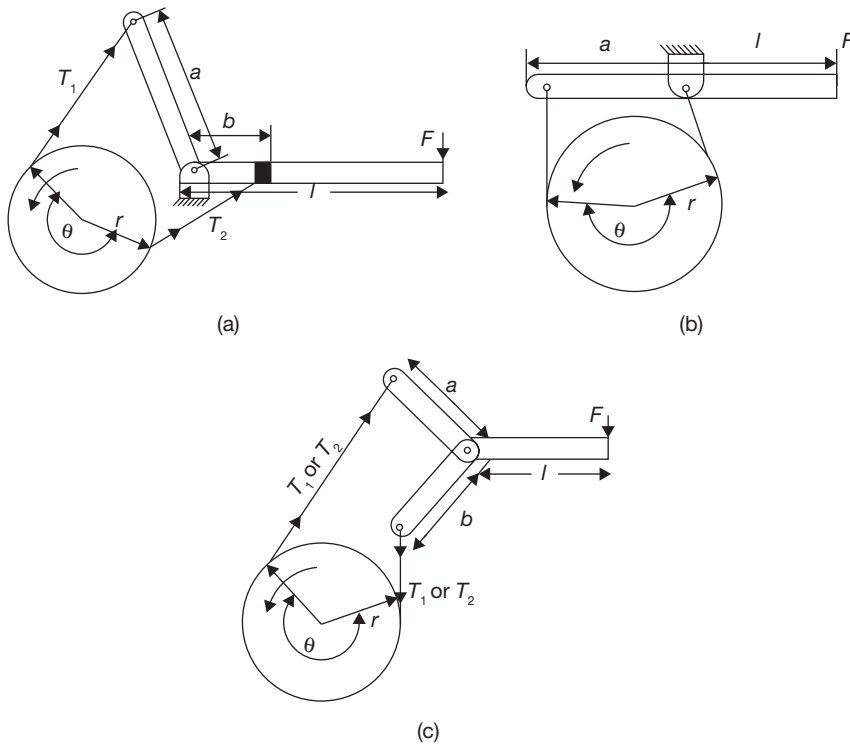
**Case I:** when  $a > b$  and  $F$  acts in downward direction and drum rotates in counter clockwise direction.

In Figure 16.9 (a),  $F \times l - T_1 \times a + T_2 \times b = 0$

$$\text{or} \quad F = \frac{T_1 \times a - T_2 \times b}{l}$$

In Figure 7.36 (b),  $F \times l - T_1 \times a = 0$

$$\text{or} \quad F = \frac{T_1 \times a}{l}$$

**FIGURE 16.9**

Band Brake

In Figure 7.36 (b),  $a = b$

or 
$$F = \frac{(T_1 + T_2) \times a}{l}$$

**Case II:** when  $a < b$  and  $F$  acts in downward direction and drum rotates in clockwise direction. In this case, the tensions on the tight side and slack side are reversed, i.e.,  $T_2 > T_1$  and  $a > b$ . Brake will be effective only when  $T_1 a > T_2 b$ .

$$\frac{T_2}{T_1} < \frac{a}{b}$$

When  $\frac{T_2}{T_1} \geq \frac{a}{b}$ ,  $F$  becomes zero or negative, i.e., the brake becomes self-locking.

**Case III:** When  $a < b$  and  $F$  acts in upward direction and drum rotates in counter clockwise direction.

$$F \times l + T_1 \times a - T_2 \times b = 0$$

$$\text{or } F = \frac{T_2 \times b - T_1 \times a}{l}$$

As  $T_2 < T_1$  and  $b > a$ , brake will be effective only when  $T_2 \times b > T_1 \times a$  or  $\frac{T_1}{T_2} < \frac{b}{a}$ .

If  $\frac{T_1}{T_2} \geq \frac{b}{a}$ , brake becomes self-locking since force required is zero or negative.

**Case IV:** When  $a < b$  and  $F$  acts in upward direction and drum rotates in clockwise direction.  $T_2 > T_1$  and  $b > a$ . when  $a = b$ , the band cannot be tightened and thus, the brake cannot be applied.

### EXAMPLE 16.9

In a differential band brake as shown in Figure 16.9 (a), following data are given:

Drum diameter = 1000 mm,  $a = 50$  mm,  $b = 250$  mm,  $\theta = 270^\circ$ ,  $\mu = 0.3$ ,  $r = d/2 = 500$  mm,  $F = 500$  N,  $l = 1200$  mm. Calculate braking torque.

#### SOLUTION

(i) Since  $a < b$  and  $F$  acts in downward direction and drum rotates in clockwise direction.

$$F \times l - T_1 \times a - T_2 \times b = 0$$

$$\frac{T_1}{T_2} = e^{\mu\theta} = e^{0.3 \times 270 \times \frac{\pi}{180}} = 4.111$$

$$T_1 = 4.111 T_2$$

$$\text{Now, } F \times l + 4.111 T_2 \times a - T_2 \times b = 0 \quad \text{or} \quad 500 \times 1200 + 4.111 T_2 \times 5 - T_2 \times 250 = 0$$

$$\Rightarrow T_2 = 13498.313 \text{ N}$$

$$T_1 = 55491.564 \text{ N}$$

$$\text{Braking torque, } T_B = (T_1 - T_2) \times r = (55491.564 - 13498.313) \times 500 = \mathbf{20.99 \text{ kNm}}$$

(ii) When drum rotates in counter clockwise direction.

$$F \times l - T_1 \times a - T_2 \times b = 0 \quad \text{and} \quad \frac{T_2}{T_1} = 4.111$$

$$\text{or } 500 \times 1200 + T_1 \times 50 - 4.111 T_1 \times 250 = 0$$

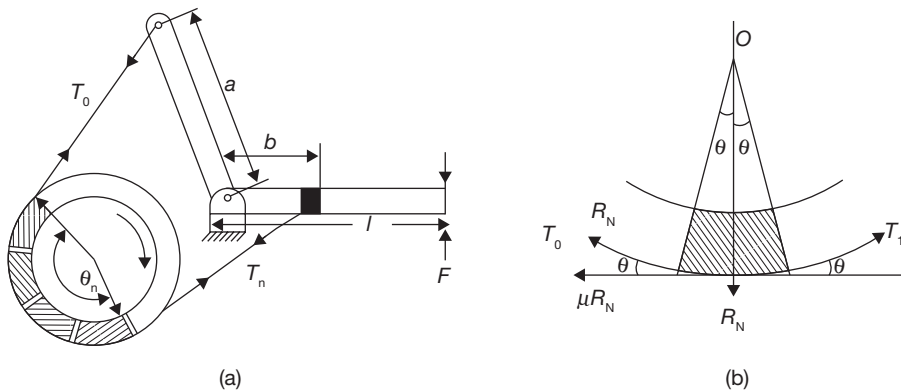
$$60,000 + T_1 (50 - 1027.75) = 0$$

$$T_1 = 613.65 \text{ N}; \quad T_2 = 2522.73 \text{ N}$$

$$\text{Braking torque, } T_B = (T_2 - T_1) \times 500 = (2522.73 - 613.65) \times 500$$

$$= \mathbf{954.54 \text{ Nm}}$$

## 16.10.3 Band and Block Brake

**FIGURE 16.10**

Band and Block Brake

This is a combination of band and block brake. A number of blocks are mounted on the drum and inside the band and brake is applied by pressing the blocks against the drum with the help of the band. To increase the effectiveness of brake blocks are used under the band since blocks have a higher coefficient of friction.

Let  $T_0$  = Tension in band on slack side  
 $T_1$  = Tension in band after one block

-----  
 $T$  = Tension in band after  $n^{\text{th}}$  block  
 $\mu$  = coefficient of friction

Forces on the block are shown in Figure 16.10 (b).

$$(T_1 - T_0) \cos \theta = \mu R_N \quad \text{and} \quad (T_1 + T_0) \sin \theta = R_N$$

or

$$\frac{T_1 - T_0}{T_1 + T_0} = \mu \tan \theta$$

$$\Rightarrow \frac{(T_1 - T_0) + (T_1 + T_0)}{(T_1 + T_0) - (T_1 + T_0)} = \frac{\mu \tan \theta + 1}{\mu \tan \theta - 1}$$

or

$$\frac{T_1}{T_0} = \frac{1 + \mu \tan \theta}{1 - \mu \tan \theta}$$

Similarly,

$$\frac{T_2}{T_1} = \frac{1 + \mu \tan \theta}{1 - \mu \tan \theta}$$

-----



$$\frac{T_n}{T_{n-1}} = \frac{1 + \mu \tan \theta}{1 - \mu \tan \theta}$$

$$\frac{T_n}{T_0} = \frac{T_n}{T_{n-1}} \times \frac{T_{n-1}}{T_{n-2}} \times \dots \times \frac{T_2}{T_1} \times \frac{T_1}{T_0}$$

$$\frac{T_n}{T_0} = \left( \frac{1 + \mu \tan \theta}{1 - \mu \tan \theta} \right)^n$$

**EXAMPLE 16.10**

There are 15 blocks in a band and block brake. Each block subtends  $30^\circ$  angle at center. The data given for the brake are: radius of drum = 250 mm, block thickness = 50 mm, coefficient of friction = 0.3,  $a = 500$  mm,  $b = 40$  mm,  $F = 300$  N,  $l = 1000$  mm. Calculate the braking torque.

**SOLUTION**

$$\frac{T_n}{T_0} = \left( \frac{1 + \mu \tan \theta}{1 - \mu \tan \theta} \right)^n = \left( \frac{1 + 0.3 \tan 15^\circ}{1 - 0.3 \tan 15^\circ} \right)^{15} = 11.2$$

$$T_n = 11.2 T_0$$

Here,  $a > b$ , therefore,  $F$  should be downward and drum rotates in clockwise direction.

Taking moment about fulcrum, we get

$$F \times l - T_0 \times a + T_n \times b = 0$$

$$300 \text{ N} \times l - T_0 \times 0.5 \text{ m} + 11.2 T_0 \times 0.04 \text{ m} = 0$$

$$T_0 = \frac{300 \text{ N}}{0.052} = 5769.2 \text{ N}$$

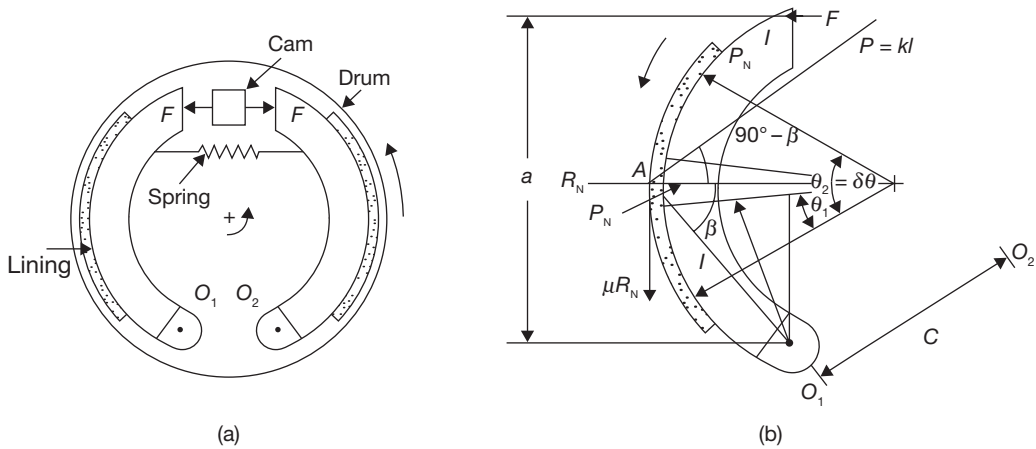
$$T_n = 11.2 \times 5769.2 \text{ N} = 64615.3 \text{ N}$$

$$\text{Braking torque, } T_B = (T_n - T_0) \times (r + t) = (64615.3 \text{ N} - 5769.2 \text{ N})(0.125 \text{ m} + 0.025 \text{ m})$$

$$= 8826.9 \text{ Nm}$$

**16.10.4 Internal Expanding Shoe Brake**

Internal expanding shoe brake has two semicircular shoes which are lined with friction materials. The outer diameter of the shoe is less than the inner diameter of the drum so that the drum can rotate freely. When the brake is applied, the shoes expand and press the



**FIGURE 16.11**

Internal Expanding Shoe Brake

inner surface of the drum and resist the motion. Working of internal expanding shoe brake is shown in Figure 16.11.

It is used in an automobile. It is self-energizing and good heat dissipative. A hydraulic pressure is generated in piston-cylinder arrangement. This hydraulic force is applied equally to both the shoes in the direction shown in Figure 16.11 (a). For counterclockwise rotation of the drum, the left shoe is primary leading shoe while the right shoe is secondary or trailing shoe. The pressure at any point A on the surface will be proportional to its distance  $l$  from the pivots.

$$P \propto l \quad \text{or} \quad P = K_1 \times l \quad \text{The direction of } P \text{ is perpendicular to } OA.$$

$$\text{Normal pressure,} \quad P_N = K_1 \times l \times \cos(90^\circ - \beta) = K_1 \times l \times \sin \beta$$

$$l \sin \beta = C \sin \theta$$

$$P_N = K_1 \times C \times \sin \theta = K_2 \sin \theta \quad \text{where} \quad K_1 \times C = K_2$$

The normal pressure will be maximum when  $\theta$  is equal to  $90^\circ$ . Thus  $P_{N_{\max}} = K_2 = P_N^l$

$P_N^l$  = Maximum pressure interfaced by leading shoe.

$$P_N = K_2 \sin \theta = P_N^l \sin \theta$$

Let  $b$  = width of brake lining

$\mu$  = coefficient of friction

consider a small element of brake lining on the leading shoe that makes an angle  $\delta\theta$  at the center.

$$R_N^l = \text{Area} \times \text{Pressure} = (r \delta\theta \times b) P_N = (r \delta\theta \times b) P_N^l \sin \theta$$

Taking moment about fulcrum  $O_1$ , we get

$$F \times a - \int_{\theta_1}^{\theta_2} r \times b \times P_N^l C \sin^2 \theta d\theta + \int_{\theta_1}^{\theta_2} \mu \times r^2 \times b \times P_N^l \sin \theta d\theta - \int_{\theta_1}^{\theta_2} \mu \times r \times b \times C \times P_N^l \sin \theta \cos \theta d\theta = 0$$

$$\text{or } F \times a - \frac{r \times C \times b \times P_N^l}{4} (2\theta_2 - 2\theta_1 - \sin 2\theta_2 + \sin 2\theta_1) + \frac{\mu \times r \times b \times P_N^l}{4} [4r(\cos \theta_1 - \cos \theta_2) - C(\cos 2\theta_1 - \cos 2\theta_2)] = 0$$

Similarly, taking moment about fulcrum  $O_2$ , we get

$$F \times a - \frac{r \times C \times b \times P_N^t}{4} (2\theta_2 - 2\theta_1 - \sin 2\theta_2 + \sin 2\theta_1) + \frac{\mu \times r \times b \times P_N^t}{4} [4r(\cos \theta_1 - \cos \theta_2) - C(\cos 2\theta_1 - \cos 2\theta_2)] = 0$$

Here,  $t$  superscript is used for trailing shoe.

Thus, the maximum pressure intensities on leading and trailing shoes can be determined.

$$\begin{aligned} \text{Braking torque, } T &= \int_{\theta_1}^{\theta_2} \mu \times r^2 \times b \times P_N^l \sin \theta d\theta + \int_{\theta_1}^{\theta_2} \mu \times r^2 \times b \times P_N^t \sin \theta d\theta \\ &= \mu \times r^2 \times b (P_N^l + P_N^t) (-\cos \theta)_{\theta_1}^{\theta_2} \end{aligned}$$

$$\text{or } T = \mu \times r^2 \times b (P_N^l + P_N^t) (\cos \theta_1 - \cos \theta_2)$$



## RECAP ZONE .....

### Points to Remember

- **Coupling** is a device used to connect two shafts together at their ends for transmitting the power.
- **Rigid couplings** are designed to draw two shafts together tightly so that no relative motion can occur between them.
- In a **flexible coupling**, the bushed coupling the rubber bushings over the pins (bolts) provide flexibility and these coupling can accommodate some misalignment.
- To accommodate misalignment between mating shafts for more than the  $3^\circ$ , a universal joint is used.
- Angular misalignments of up to  $45^\circ$  are possible at low rotational speeds with single universal joints.
- **Clutch** is a device which is used to engage and disengage the driven shaft from driving shaft during the motion to change the gears meshing without stopping the driving shaft.
- The function of **multi-disc clutch** is similar to the single plate clutch but the number of discs in the multi-disc clutch is more than one.
- In a **cone clutch**, the friction surfaces make a cone of an angle  $(2\beta)$ .
- **Centrifugal clutch** works on the principle of centrifugal force. When the driving shaft rotates at high speed, the shoes move radially outward.
- The outer surfaces of the shoes are covered with friction material which engages the pulley. Thus, pulley rotates with the driving shaft. The engagement of shoes with the pulley.
- The **brake** is a device which is used to bring the body into rest while it is in motion or to hold a body in a state of rest by applying resisting force.
- **Band brake** consists of a band in the form of belt, rope or steel band. When force is applied at the free end of the lever, the band is pressed against the external surface of the drum.
- **Band and Block brake** is a combination of band and blocks. A number of blocks are mounted on the drum and inside the band and brake is applied by pressing the blocks against the drum with the help of the band.
- **Internal expanding shoe brake** has two semicircular shoes which are lined with friction materials.

### Important Formulae

1. Torque on single plate disc clutch

(a) Uniform pressure

$$T = \frac{2}{3} \mu W \left[ \frac{r_1^3 - r_2^3}{r_1^2 - r_2^2} \right] = \mu W R$$

where  $R$  is mean radius and equals to  $\frac{2}{3} \left[ \frac{r_1^3 - r_2^3}{r_1^2 - r_2^2} \right]$

(b) Uniform wear

$$T = \frac{1}{2} \mu W (r_1 + r_2) = \mu W R$$

where  $R$  is mean radius and equals to  $\frac{1}{2}(r_1 + r_2)$

2. Multi-plate disc clutch  
 (a) Torque for uniform pressure

$$T = n \times \frac{2}{3} \mu W \left[ \frac{r_1^3 - r_2^3}{r_1^2 - r_2^2} \right]$$

- (b) Torque for uniform wear

$$T = n \times \frac{1}{2} \mu W (r_1 + r_2)$$

3. Cone clutch  
 (a) Torque for uniform pressure

$$T = \frac{2}{3} \mu W \left[ \frac{r_1^3 - r_2^3}{r_1^2 - r_2^2} \right] \operatorname{cosec} \beta$$

- (b) Torque for uniform wear

$$T = \frac{1}{2} \mu W (r_1 + r_2) \pm \operatorname{cosec} \beta$$

4. Centrifugal clutch

Torque,  $T = F \times R = \mu . n . (F_c - F_s) . R$  where  $n$  is a number of shoes.

5. Band and block brake:  $\frac{T_n}{T_o} = \left( \frac{1 + \mu \tan \theta}{1 - \mu \tan \theta} \right)^n$

6. Internal expanding shoe brake

Braking torque;  $T = \mu \times r^2 \times b (P_N^l + P_N^r) (\cos \theta_1 - \cos \theta_2)$

## REVIEW ZONE



### Multiple-choice Questions

- The friction moment in clutches with assumption of uniform wear as compared to uniform pressure is:
  - More
  - Less
  - Same
  - None of these
- If  $\phi$  be the angle of friction, then radius of friction circle is given by:
  - $r$
  - $r \sin \phi$
  - $r \cos \phi$
  - None of these
- Friction radius in comparison to worn-out will be:
  - Same
  - More
  - Less
  - None of these
- For new clutches and brakes, friction radius is equal to:
  - $\frac{D+d}{4}$
  - $\frac{1}{3} \frac{D^3-d^3}{D^2-d^2}$
  - $\frac{1}{2} \frac{D^3-d^3}{D^2-d^2}$
  - $\frac{1}{3} \frac{D^2-d^2}{D^3-d^3}$
- For uniform wear condition of brakes and clutches, friction radius is equal to:
  - $\frac{D+d}{4}$
  - $\frac{1}{3} \frac{D^2-d^2}{D^2-d^2}$
  - $\frac{1}{2} \frac{D^3-d^3}{D^2-d^2}$
  - $\frac{1}{3} \frac{D^2-d^2}{D^3-d^3}$
- The commonly used angle between the cone surface and horizontal axis for a cone clutch utilizing leather to asbestos lining is about:
  - $8^\circ$
  - $12.5^\circ$
  - $20^\circ$
  - $30^\circ$
- In a cone clutch, a given torque can be transmitted by a relatively small axial force if the cone face angle is:
  - More
  - Less
  - Same
  - Any angle

8. For a block brake, the equivalent coefficient of friction is equal to:
- (a)  $\frac{4 \sin \theta}{2\theta + \sin 2\theta} \mu$       (b)  $\frac{2 \sin \theta}{2\theta + \sin 2\theta} \mu$
- (c)  $\frac{4 \sin 2\theta}{2\theta + \sin 2\theta} \mu$       (d)  $\frac{2 \sin 2\theta}{2\theta + \sin 2\theta} \mu$
9. The percentage of total brake effort that results from self-energizing action depends on:
- (a) The location of brake arm pivot point  
 (b) The coefficient of friction  
 (c) The direction of rotation of the brake drum  
 (d) All of the above
10. In order to prevent the brake arm from grabbing, the moment of friction force about the brake arm pivot point should be:
- (a) Less than the total required braking effort  
 (b) Greater than the total required braking effort  
 (c) Equal to the total required braking effort  
 (d) None of these
11. Coupling, which prevents transmission of shock from one shaft to another, is known as:
- (a) Oldham coupling    (b) Universal coupling  
 (c) Flexible coupling    (d) Jaw coupling
12. In flange coupling, the weakest element is:
- (a) Flange                      (b) Bolt  
 (c) Key                          (d) Shaft
13. A flange coupling is a:
- (a) Rigid coupling    (b) Flexible coupling  
 (c) Both (a) and (b)    (d) None of these
14. In flange coupling, the flanges are joined together by:
- (a) Head less taper bolts  
 (b) Rivets  
 (c) Nuts and bolts  
 (d) Studs
15. Number of bolts in flange coupling should not be less than:
- (a) 2                              (b) 3  
 (c) 4                              (d) 8
16. A universal coupling is:
- (a) Rigid coupling    (b) Flexible coupling  
 (c) Both (a) and (b)    (d) None of these
17. A universal coupling is used to connect:
- (a) Whose axes intersect at a small angle  
 (b) Which are perfectly aligned  
 (c) Which are not aligned  
 (d) Have lateral misalignment

## Answers

- |         |         |         |         |         |         |
|---------|---------|---------|---------|---------|---------|
| 1. (b)  | 2. (b)  | 3. (b)  | 4. (b)  | 5. (a)  | 6. (b)  |
| 7. (b)  | 8. (a)  | 9. (d)  | 10. (a) | 11. (c) | 12. (c) |
| 13. (a) | 14. (c) | 15. (b) | 16. (b) | 17. (a) |         |

## Theory Questions

- Explain the advantages and disadvantages of flexible and rigid couplings.
- Explain the role of clutch in power transmission.
- Derive the formula for torque transmitted by a single plate disc clutch assuming uniform pressure.
- Derive the formula for torque transmitted by a cone clutch assuming uniform wear.
- Which of the two assumptions: uniform pressure and uniform wear would you like to use in designing friction clutch? Explain the reasons.
- Describe the working of centrifugal clutch and express the equation for torque transmitted.
- What is the use of the braking system in a vehicle? Classify the various types of brakes.
- Describe the working of internal shoe expanding brake with a neat sketch. Also, derive the expression for braking torque.
- Prove in the band-block brake.

$$\frac{T_0}{T_n} = \left( \frac{1 + \mu \tan \theta}{1 - \mu \tan \theta} \right)^n$$

10. Differentiate the functions of coupling, clutch, and brake.
- \*11. What is a brake? Describe an internal expanding shoe brake with a neat sketch and state its applications.
- \*12. Explain with a suitable diagram, working principle of disc clutch and band brake.
- \*13. What is coupling? Explain internal expanding shoe brake with a neat sketch.
- \*14. What are the different types of couplings? Explain the centrifugal clutch.
- \*15. What are bearings? Explain with neat sketch worm and worm wheel.
- \*16. What is brake? How does it differ from clutch? What are various types of clutches? Name type of clutch is used in scooter and car.
- \*17. Explain the working of friction clutch with a neat sketch.

## Numerical Problems

1. A single plate clutch of both sides effective has outer and inner radii as 300 and 200 mm. The maximum intensity of pressure at any point in the contact surface should not exceed to  $0.1 \text{ N/m}^2$ . If the coefficient of friction is 0.3, find the power transmitted by the clutch at the speed of 2500 rpm. Assuming: (i) uniform wear, and (ii) uniform pressure.
2. A multi-disc clutch has 3-discs on the driving shaft and 2-discs on the driven shaft. Outside radius of the contact surface is 180 mm and inside radius is 120 mm. Assuming uniform wear and coefficient of friction is 0.3. Find the maximum axial intensity of pressure between the discs for transmitting 25 kW at 1,500 rpm.
3. A cone clutch has a cone angle of  $40^\circ$ . The maximum pressure between contact surface is limited to  $0.3 \text{ N/m}^2$  and width of conical surface is half of the mean radius, find the radii of the conical surface to transmit 30 kW at 2,000 rpm. Assume uniform wear and coefficient of friction as 0.3.
4. There are four shoes in the centrifugal clutch. The mass of each shoe is 5 kg. When the clutch is at rest, the force exerted by spring on shoes is 200 N. The clearance between shoes and drum is 4 mm. Spring constant is 25 N/mm. The distance of the center of mass of shoes from the axis is 100 mm. The internal diameter of the drum of 225 mm. The coefficient of friction of the brake lining is 0.3. Find the power transmitted by the clutch at 500 rpm.
5. A single block brake, as shown in Figure 16.8 (a), has brake drum diameter of 250 mm. It can withstand 300 Nm torque at 500 rpm. The coefficient of friction between block and drum is 0.25. Determine the force (P) required to apply when the drum rotates in: (i) clockwise direction, and (ii) counter clockwise direction. Given: angle of contact ( $2\theta$ ) =  $100^\circ$ ,  $x = 150 \text{ mm}$ ,  $a = 40 \text{ mm}$ ,  $l = 1000 \text{ mm}$ .
6. In a double block brake, as shown in Figure 16.8 (c), has drum radius = 400 mm, angle of contact ( $2\theta$ ) =  $30^\circ$ , coefficient of friction ( $\mu$ ) = 0.25, the force applied on spring = 10 kN, and  $x = 0.4 \text{ m}$ ,  $l = 1 \text{ m}$ , and  $c = 0.1 \text{ m}$ . Find the braking torque applied.
7. In a differential band brake as shown in Figure 16.9 (a), the data are given as: radius = 400 mm,  $a = 40 \text{ mm}$ ,  $b = 200 \text{ mm}$ ,  $l = 1,000 \text{ mm}$ ,  $\theta = 270^\circ$ ,  $\mu = 0.25$ ,  $F = 600 \text{ N}$ . Calculate the braking torque.
8. In a band and block brake, as shown in Figure 16.10 (a), the data are given as:  $n = 12$ , angle subtended by each block =  $30^\circ$ , radius of drum = 300 mm, block thickness = 40 mm,  $\mu = 0.3$ ,  $a = 400 \text{ mm}$ ,  $b = 40 \text{ mm}$ ,  $F = 400 \text{ N}$ ,  $l = 800 \text{ mm}$ . Calculate the braking torque.
9. Following data are given for internal shoe expanding brake as shown in Figure 16.11 (b): Force on each shoe = 500 N, internal radius of brake drum ( $r$ ) = 200 mm,  $\mu = 0.3$ , width of brake lining ( $b$ ) = 40 mm,  $a = 25 \text{ mm}$ ,  $C = 125 \text{ mm}$ ,  $\theta_1 = 40^\circ$ , and  $\theta_2 = 160^\circ$ . Find the braking torque when the drum rotates in (i) clockwise direction, and (ii) counter clockwise direction.

\* indicates that similar questions have appeared in various university examinations.

## Learning Objectives

*By the end of this chapter, the student will be able:*

- To understand the properties and compositions of the engineering materials
- To demonstrate the mechanical properties of the engineering materials
- To describe the alloys of ferrous and non-ferrous materials
- To describe the composition and applications of plastics, ceramics, timber, polymer, and composite materials

### 17.1 ► INTRODUCTION

Engineering materials play a vital role in this modern age of science and technology. Various kinds of materials are used in industry to meet the requirements of human beings. The selection of a specific material for a particular use is a very complex process. However, one can simplify the choice if the details about (i) Use parameters, (ii) manufacturing processes, (iii) functional requirements, and (iv) cost considerations are known. While selecting materials for engineering purposes, properties such as impact strength, tensile strength, and hardness indicate the suitability for selection but the design engineer will have to make sure that the radiography and other properties of the material are as per the specifications.

In recent years polymeric materials or plastics have gained considerable popularity as engineering materials. Though inferior to most metallic materials in strength and temperature resistance, these are being used not only in the corrosive environment but also in the places where minimum wear is required, e.g. small gear wheels, originally produced from hardened steels, are now manufactured from Nylon or Teflon. These materials perform satisfactorily, are quiet and do not require lubrication.



## 17.2 ► MECHANICAL PROPERTIES OF ENGINEERING MATERIALS

The important mechanical properties are listed below:

**Tensile Strength:** This enables the material to resist the application of a tensile force. The internal structure of the material provides the internal resistance to withstand the tensile force. Ultimate strength is the unit stress; measures in *kgf* per square millimeter, developed in the material by the maximum slowly applied a load that material can withstand without rupturing in a tensile test.

**Shear Strength:** It is the ability of a material to resist the shear force applied to the material.  
**Compressive Strength:** It is the ability of a material to withstand pressures acting on a given plane.

**Elasticity:** It is the property of material due to which it returns to its original shape and size after releasing the load. Any material that is subjected to an external load is distorted or strained. Elastically stressed materials return to their original dimensions when the load is released.

**Hardness:** It is the degree of resistance to indentation, scratching, abrasion, and wear. Alloying techniques and heat treatment help to achieve the same.

**Ductility:** This is the property of a metal by virtue of which it can be drawn into wires or elongated before rupture takes place. It depends upon the grain size of the metal crystals.

**Malleability:** It is the property of a metal to be deformed or compressed permanently into the sheet without fracture. It shows the ability of the material to be rolled or hammered into thin sheets.

**Impact Strength:** It is the energy required per unit cross-sectional area to fracture a specimen, i.e., it is a measure of the response of a material to shock loading.

**Toughness:** It is the ability of the material to absorb energy before fracture or rupture. It may be presented as impact strength of the material.

**Brittleness:** The term “brittleness” implies sudden failure. It is the property of breaking without warning, i.e., without visible permanent deformation.

**Wear Resistance:** The ability of a material to resist friction wear under particular conditions, i.e., to maintain its physical dimensions when in sliding or rolling contact with a second member.

**Corrosion Resistance:** Those metals and alloys which can withstand the corrosive action of a medium, i.e., corrosion processes proceed in them at a relatively low rate that are termed as corrosion-resistant.

**Density:** This is an important factor of a material where weight and thus the mass is critical, i.e., aircraft components.

## 17.3 ► MECHANICAL TESTING OF ENGINEERING MATERIALS

### 17.3.1 Tensile Test

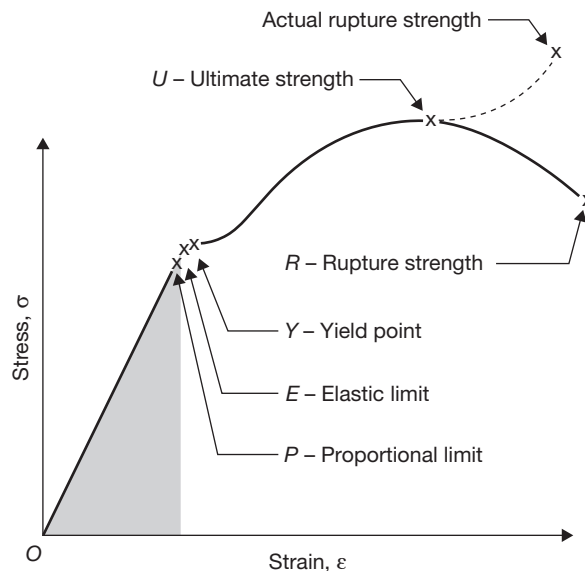
*Hook's Law:* Hook's law states that stress and strain are perpendicular to each other under the elastic limit. Originally, Hooke's law specified that stress was proportional to strain but Thomas Young introduction constant of proportionality which is known as Young's modulus. Further, this name was superseded by modulus of elasticity.

$$E = \frac{\sigma}{\epsilon}$$

Where E is the modulus of elasticity;  $\sigma$  is stress and  $\epsilon$  is strain.

#### *Stress–Strain Diagram*

The stress-strain diagram can be drawn with the help of a universal testing machine (UTM). To draw stress-strain diagram a specimen is fixed in the jaws of UTM. A gauge length of the specimen is fixed according to its diameter. Now, gradually increasing tensile load is applied to the specimen and extension is recorded by extensometer corresponding to the load shown by the dial. Two types of the curve are plotted. The solid line shows engineering stress-strain diagram and the dotted line shows true stress-strain diagram as shown in Figure 17.1.



**FIGURE 17.1**

Stress-strain Diagram for Medium Carbon Steel

A stress-strain diagram is a graph that represents how a part behaves under an increasing load and is often used by engineers when selecting materials for specific designs. A stress-strain diagram generally contains three parts:

- (i) Elastic Deformation – The elastic deformation portion of the stress-strain diagram is generally represented as a linear relationship between stress and strain. If the load is released while the specimen is in the elastic deformation zone, it will return to its original dimensions.
- (ii) Plastic Deformation – In the plastic deformation portion of the stress-strain diagram, the specimen begins to yield. The maximum strength of the specimen occurs in this zone, and the carried load begins to drop off as the deformation increases. The specimen endures some permanent deformation that remains after the load is released.
- (iii) Rupture – The point at which a specimen breaks into two parts.

Stress-strain diagrams are generated experimentally through the performance of controlled tensile tests using precisely fabricated test specimens. The applied load and displacement are monitored during the test and are used to calculate stress and strain, respectively.

**Proportional Limit (Hooke's Law):** From the origin  $O$  to the proportional limit, the stress-strain curve is linear in nature. This linear relation between elongation and the axial force was first noticed by Sir Robert Hooke in 1678 and is called Hooke's Law that within the proportional limit, the stress is directly proportional to strain or  $\sigma \propto \epsilon$  or  $\sigma = k \epsilon$ . The constant of proportionality is called the Modulus of Elasticity  $E$  or Young's Modulus and is equal to the slope of the stress-strain diagram from  $O$  to  $P$ , i.e.,  $\sigma = E \epsilon$ .

**Elastic Limit:** The elastic limit is the limit beyond which the material will no longer go back to its original shape when the load is removed, or it is the maximum stress under which there is no permanent or residual deformation after removal of this load.

**Elastic and Plastic Ranges:** The region in the stress-strain diagram from  $O$  to  $P$  is called the elastic range. The region from  $P$  to  $R$  is called the plastic range.

**Yield Point:** Yield point is the point at which the material will have an appreciable elongation or yielding without any increase in load.

**Ultimate Strength:** The maximum ordinate in the stress-strain diagram is the ultimate strength or tensile strength. Necking starts from this point.

**Rapture Strength:** Rapture strength is the strength of the material at rapture point. This is also known as the breaking strength.

**Modulus of Resilience:** Modulus of resilience is the work done on a unit volume of material as the force is gradually increased from  $O$  to  $P$ , in  $N \cdot m/m^3$ . This may be calculated as the area under the stress-strain curve from the origin  $O$  to up to the elastic limit  $E$  (the shaded area

in Figure 17.1). The resilience of the material is its ability to absorb energy without creating a permanent distortion.

**Modulus of Toughness:** Modulus of Toughness is the work done on a unit volume of material as the force is gradually increased from  $O$  to  $R$ , in  $\text{N}\cdot\text{m}/\text{m}^3$ . This may be calculated as the area under the entire stress-strain curve (from  $O$  to  $R$ ). The toughness of a material is its ability to absorb energy without causing it to break.

**Working Stress, Allowable Stress, and Factor of Safety:** Working stress is defined as the actual stress of a material under a given loading. The maximum safe stress that a material can carry is termed as the allowable stress. The allowable stress should be limited to values not exceeding the proportional limit. However, since the proportional limit is difficult to determine accurately, the allowable stress is taken as either the yield point or ultimate strength divided by a factor of safety. The ratio of this strength (ultimate or yield strength) to allowable strength is called the factor of safety.

The relationship between gauge length and cross-sectional area of the tensile test specimen can be given as  $L_{\text{gauge}} = 5.65\sqrt{A}$ , where  $A$  is an area of cross-section.

### 17.3.2 Hardness

Hardness means the resistance to penetration. Testing for hardness can be divided into three categories:

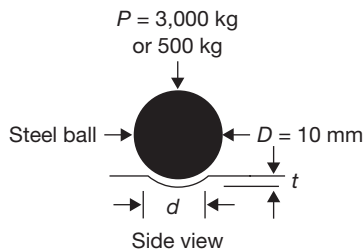
- ▶ Scratch tests
- ▶ Rebound tests
- ▶ Indentation tests

Scratch tests involve comparatively scratching progressively harder materials. Mohs hardness scale is used for the test. Diamond, the hardest material, is assigned a value of 10. Decreasing values are assigned to other minerals, down to 1 for the soft mineral, talc. Decimal fractions are used for materials intermediate between the standard ones. Where a material lies on the Mohs scale is determined by a simple manual scratch test. If two materials are compared, the harder one is capable of scratching the softer one, but not vice versa. This allows materials to be ranked as to hardness, and decimal values between the standard ones are assigned as a matter of judgment.

Rebound test employs techniques to assess the resilience of material by measuring changes in potential energy. For example, the Sceleroscope hardness test employs a hammer with a rounded diamond tip. This hammer is dropped from a fixed height onto the surface of the material being tested. The hardness number is proportional to the height of rebound of the hammer with the scale for metals being set so that fully hardened tool steel has a value of 100. A modified version is also used for polymers.

Indentation tests produce a permanent impression in the surface of the material. The force and size of the impression can be related to a quantity (hardness), which can be related to the resistance of the material to permanent penetration. Because the hardness is a function of the force and size of the impression, the pressure (stress) used to create the impression can be related to both the yield and ultimate strengths of materials. Several different types of hardness tests have evolved over the years. These include macro hardness tests such as Brinell, Vickers, and Rockwell and microhardness tests such as Knoop and Tukon.

**A. Brinell Hardness Test:** In this test, a steel ball is used with a relatively large force. The force is usually obtained different for different materials. The Brinell hardness number is obtained by dividing the applied force,  $P$ , in kg, by the actual surface area of the indentation which is a segment of a sphere.



$$BHN = \frac{P}{\pi Dt} = \frac{2P}{\pi \left[ D - \sqrt{D^2 - d^2} \right]}$$

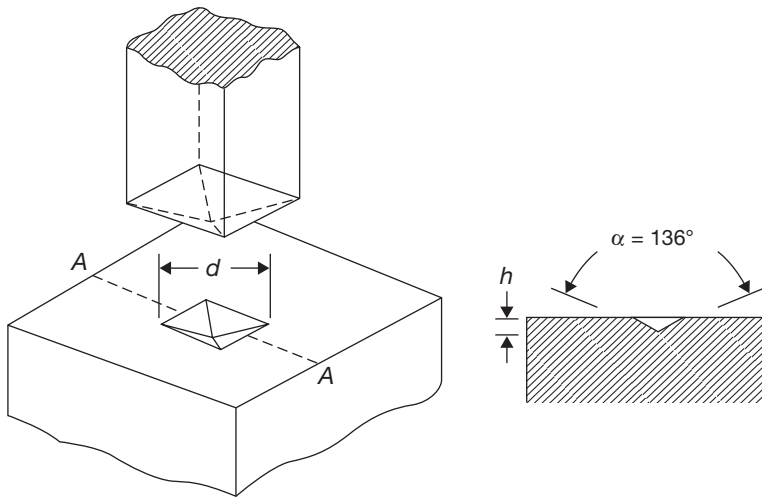
Where  $D$  is the diameter of the ball in mm,  $d$  is the diameter of the indentation at the surface in mm, and  $t$  is the depth of the indentation from the surface.

Brinell hardness is good for averaging heterogeneities over a relatively large area, thus lessening the influence of scratches or surface roughness. However, the large ball size precludes the use of Brinell hardness for small objects or critical components where large indentations may promote failure. Another limitation of the Brinell hardness test is that because of the spherical shape of the indenter ball, the BHN for the same material will not be the same for different loads if the same size ball is used. Thus, geometric similitude must be imposed by maintaining the ratio of the indentation load and indenter.

$$\frac{P_1}{D_1} = \frac{P_2}{D_2} = \frac{P_3}{D_3}$$

The load on the ball depends on its diameter. The ratio of load and square of ball diameters are different for different materials, for example, for steel  $\frac{P}{D^2} = 30$ , for copper  $\frac{P}{D^2} = 10$ , and for aluminum  $\frac{P}{D^2} = 5$ .

- B. Vickers Hardness Test:** In Vickers hardness test, the principle of operation is same as in Brinell hardness test. However, a four-sided diamond pyramid is implied as an indenter rather than a ball to promote geometric similarity of indentation regardless of indentation load (Figure 17.2). The included angle between the faces of the pyramid is  $136^\circ$ . The resulting Vickers indentation has a depth,  $h$  equal to  $1/7$  of the indentation size ( $L$ ) measured on the diagonal. The Vickers hardness is obtained by dividing the applied force by the surface area of the impression.



**FIGURE 17.2**

Vickers Hardness Test

$$VHN = \frac{2P}{L^2} \sin \frac{\alpha}{2}$$

where  $P$  is the indentation load which typically ranges from 0.1 to 1 kg but may be as high as 120 kg,  $L$  is the diagonal of the indentation in mm and  $\alpha$  is the included angle of  $136^\circ$ . The main advantage of the Vickers hardness is that the result is independent of load. However, disadvantages are that it is somewhat slow since careful surface preparation is required. In addition, the result may be prone to personal error in measuring the diagonal length along with interpretation.

- C. Rockwell Hardness Test:** The Rockwell test is the most commonly used hardness test. In this test, penetration depth is measured, with the hardness reported as the inverse of the penetration depth. A two-step procedure is used. The first step “sets” the indenter in the material and the second steps the actual indentation test. The conical diamond or spherical indenter tips produce indentation depths, the inverse of

which is used to display hardness on the test machine directly. The reported hardness is in arbitrary units, but the Rockwell scale which identifies the indentation load and indenter tip must be reported with the hardness number. Rockwell scales include those in Table 17.1.

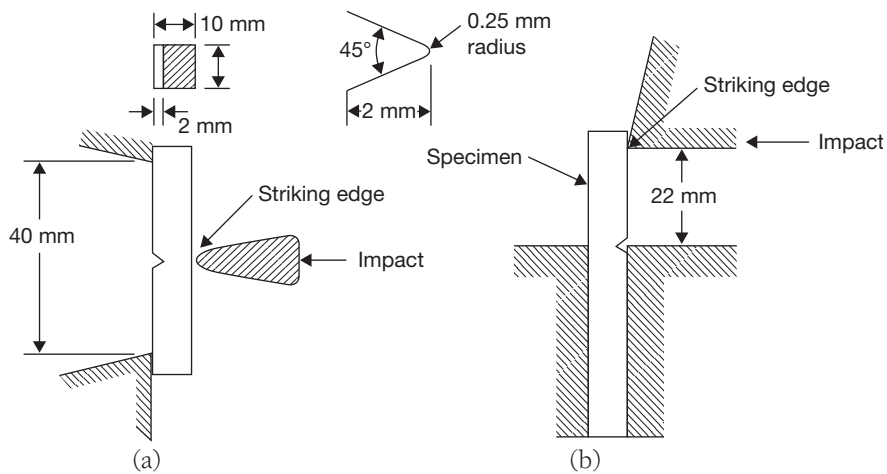
**Table 17.1: Rockwell scale and major loads**

Rockwell Scale	Indenter	Major Load
A	Brale	60
B	1/16" ball	100
C	Brale	150
D	Brale	100
E	1/8" ball	100
F	1/16" ball	60
M	1/4" ball	100

## 17.4 ► IMPACT TEST

The behavior of a material is also dependent on the rate at which the load is applied. For example, low-carbon steel shows a considerable increase in yield strength with increasing rate of strain. In addition, increased work hardening occurs at high strain rates. This result in reduced local necking, hence, a greater overall material ductility occurs. In design applications, impact situations are frequently encountered, such as cylinder head bolts, in which it is necessary for the part to absorb a certain amount of energy without failure. In the static test, this energy absorption ability is called “toughness” and is indicated by the modulus of rupture. A similar “toughness” measurement is required for dynamic loadings; this measurement is made with a standard impact test known as the Izod or Charpy test. When using one of these impact tests, a small notched specimen is broken in flexure by a single blow from a swinging pendulum. With the Charpy test, the specimen is supported as a simple beam, while in the Izod it is held as a cantilever. Figure 17.3 shows standard configurations for Izod and Charpy impact tests.

A standard Charpy impact machine is used. This machine consists essentially of a rigid specimen holder and a swinging pendulum hammer for striking the impact blow. Impact energy is simply the difference in potential energies of the pendulum before and after striking the specimen. The machine is calibrated to read the fracture energy in N-m or J directly from a pointer, which indicates the angular rotation of the pendulum after the specimen has been fractured. Similarly, Izod test is performed but the specimen is kept in the cantilever position.

**FIGURE 17.3**

(a) Charpy Test (b) Izod Test

## 17.5 ► CLASSIFICATION OF ENGINEERING MATERIALS

Common engineering materials may be classified into one of the following seven groups:

- (i) Metals (ferrous and non-ferrous) and alloys
- (ii) Ceramics
- (iii) Organic polymers
- (iv) Composites
- (v) Semi-conductors
- (vi) Biomaterials
- (vii) Advanced materials

Broadly, metallic materials are of two kinds—ferrous and non-ferrous materials. Ferrous materials are those in which iron (Fe) is the principal constituent. All other materials are categorized as non-ferrous materials.

### 17.5.1 Ferrous Metals

In ferrous materials, the main alloying element is carbon (C). Depending on the amount of carbon present, these alloys will have different properties, especially when the carbon content is either less/higher than 1.5%. This amount of carbon is specific as below this amount of carbon, the material undergoes a eutectoid transformation, while above that limit ferrous materials undergo a eutectic transformation. Thus the ferrous alloys with



less than 1.5% C are termed as steels and the ferrous alloys with higher than 2-4% C are termed as cast irons.

On the basis of the percentage of carbon and their alloying elements present, these can be classified into following groups:

- ▶ **Low Carbon Steel:** It contains up to 0.3% carbon and 1% manganese. Since its microstructure consists of ferrite and pearlite so it is relatively softer than the other carbon steel. It cannot be hardened by heat treatment. But it has good ductility and toughness. Mild steel (Carbon % 0.15–0.3) due to its good strength, high machinability, and weldability property is an extensively used engineering material. It is used as different structural sections (channel, angles, etc.), sheets, automobile components, etc.
- ▶ **Medium Carbon Steels:** These contain carbon between 0.3% and 0.6%. The strength of these materials is high but their weldability is comparatively less. Due to higher C%, it can be heat treated to get higher hardness. It is used as railway track and wheels, crankshafts, gears, etc.
- ▶ **High Carbon Steels:** These contain carbon varying from 0.65% to 1.5%. These materials get hard and tough by heat treatment and their weldability is poor. The steel formed in which carbon content is up to 1.5%, silica up to 0.5%, and manganese up to 1.5% along with traces of other elements is called plain carbon steel.
- ▶ **Cast Irons:** The carbon content in these substances vary between 2% and 4%. The cost of production of these substances is quite low and these are used as ferrous casting alloys.
- ▶ **Gray Cast Iron:** These alloys consists carbon in form graphite flakes, which are surrounded by either ferrite or pearlite. Because of the presence of graphite, fractured surface of these alloys look grayish and so is the name for them. The alloying addition of Si (1–3 wt%) is responsible for decomposition of cementite, and also high fluidity. Thus castings of intricate shapes can be easily made. Due to graphite flakes, gray cast irons are weak and brittle. However, they possess good damping properties, and thus typical applications include: base structures, bed for heavy machines, etc. they also show high resistance to wear.
- ▶ **White Cast Iron:** When Si content is low (<1%) in combination with faster cooling rates, there is no time left for cementite to get decomposed, thus most of the brittle cementite retains. Because of the presence of cementite, the fractured surface appears white, hence the name. They are very brittle and extremely difficult to machine. Hence their use is limited to wear resistant applications such as rollers in rolling mills. Usually, white cast iron is heat treated to produce malleable iron.
- ▶ **Nodular (or Ductile) Cast Iron:** Alloying additions are of prime importance in producing these materials. Small additions of Mg/Ce to the gray cast iron melt before casting can result in graphite to form nodules or sphere-like particles. Matrix surrounding these particles can be either ferrite or pearlite depending on the heat treatment. These are stronger and ductile than gray cast irons. Typical applications include pump bodies, crankshafts, automotive components, etc.

- ▶ **Malleable Cast Iron:** These formed after heat treating white cast iron. Heat treatments involve heating the material up to 800–900°C, and keep it for long hours, before cooling it to room temperature. High temperature incubation causes cementite to decompose and form ferrite and graphite. Thus these materials are stronger with appreciable amount of ductility. Typical applications include: railroad, connecting rods, marine, and other heavy-duty services.

### *Alloy Steel*

The common alloying elements are Chromium, Nickel, Molybdenum, Tungsten, Cobalt, Copper, Manganese, Silicon, and Sulfur, Phosphorous, etc. Depending on the percentage of alloying elements, mechanical properties like strength, hardness corrosion, etc. changes under different operating conditions.

### *Effect of Alloying Elements*

Some common alloying elements with their effects are discussed below:

**Manganese (Mn)** – When Manganese percentage exceeds a normal percentage (1.65%) in steel, then the steel is known as Manganese steel. Manganese up to 1.95% improves hardness, tensile strength, and hot working property. More than 2% addition of the Manganese, the steel becomes brittle. It is used as axles, connecting rods, gears, etc.

**Silicon (Si)** – The steel having more than 0.6% Si is known as Silicon steel. It acts as deoxidizer and graphitizer. As it dissolves in ferrite so it is not carbide former. It has high magnetic permeability but very low hysteresis loss. It is extensively used in electrical industries. Steel with 0.5% C and 3–4% Si is used to make a motor, transformer cores. This is known as transformer steel. More than 4% Si makes the steel brittle.

**Sulfur (S)** – Small amount (about 0.05%) Sulfur is present in normal steel. When this % increases to 0.33% it becomes easily machinable and known as free cutting steel.

**Phosphorus (P)** – Small amount (about 0.05%) is present in normal steel. If it is increased to 0.12% in low carbon steel then it improves strength, hardness, corrosion resistance, machine ability, etc. It has been assumed that the iron pillar at Kutub Minar at Delhi is corrosion free due to high contents of phosphorus in the steel.

**Nickel (Ni)** – When added up to 5% it improves static and impact load bearing properties. Higher % of Nickel addition improves corrosion resistance. Steels with 1.5–3% Ni are suitable for loco boilers, railway axles, etc.

**Chromium (Cr)** – Chromium addition in plain carbon steel improves hardenability, strength, wear resistance, corrosion, and red hot resistance if added more than 4% it improves corrosion resistance. Chromium improves hardenability so heavy a section to be hardened contains Cr. It is the prime constituent in stainless steel apart from Nickel. It is widely used in tool steel.

**Tungsten (W)** – The steel retains its hardness at a higher temperature with addition of tungsten as an alloy. It is a strong carbide former. Tungsten carbide is extremely hard and stable. It improves wear and abrasive resistance in steel. It retards softening of Martensite during tempering and gives hot hardness. So is commonly added to make tool and hot-working die steel. In High-Speed Steel (HSS), it is added up to 18%.

**Molybdenum (Mo)** – The steel becomes more wear resistant with the addition of Molybdenum. Its red hot hardness is high as compared to Carbon steel as Molybdenum Carbide can withstand higher temperature as compared to iron carbide. It is used to make aircraft components, pressure vessels, and springs. 5% Mo is added in some HSS steel.

**Vanadium (V)** – It improves red hot hardness, fatigue resistance and wear resistance property. Vanadium carbide has the highest hardness and wear resistance property amongst alloying elements added to steel. 2% Vanadium is added in some HSS.

## 17.5.2 NON-FERROUS METALS

These substances are composed of metals other than iron. However, these may contain iron in small proportion. Seven non-ferrous materials are available in sufficient quantity reasonably at low cost and used as common engineering metals. These are aluminum, tin, copper, nickel, zinc, and magnesium. Some other non-ferrous metals, about 14 in number, are produced in relatively small quantities but these are of vital importance in modern industry. These include chromium, mercury, cobalt, tungsten, vanadium, molybdenum, antimony, cadmium, zirconium, beryllium, niobium, titanium, tantalum, and manganese.

**Aluminum Alloys:** Aluminum alloys have high thermal and electrical conductivity and good corrosion resistant characteristics. As Al has FCC crystal structure, these alloys are ductile even at low temperatures and can be formed easily. However, the great limitation of these alloys is their low melting point ( $660^{\circ}\text{C}$ ), which restricts their use at elevated temperatures. The strength of these alloys can be increased by both cold and heat treatment – based on these alloys are designated into two groups, cast and wrought. Chief alloying elements include Cu, Si, Mn, Mg, Zn. Recently, alloys of Al and other low-density metals like Li, Mg, Ti gained much attention as there is much concern about vehicle weight reduction. Al-Li alloys enjoy much more attention especially as they are very useful in aircraft and aerospace industries. Common applications of Al alloys include beverage cans, automotive parts, bus bodies, aircraft structures, etc. Some of the Al alloys are capable of strengthening by precipitation, while others have to be strengthened by cold work or solid solution methods.

**Copper Alloys:** As history goes by, bronze has been used for thousands of years. It is actually an alloy of Cu and Sn. Unalloyed Cu is soft, ductile thus hard to machine, and has the virtually unlimited capacity for cold work. One special feature of most of these alloys is their

corrosion resistant in diverse atmospheres. Most of these alloys are strengthened by either cold work or a solid solution method. Common most Cu alloys: Brass, alloys of Cu and Zn where Zn is substitution addition (e.g., yellow brass, cartridge brass, Muntz metal, gilding metal); Bronze, alloys of Cu and other alloying additions like Sn, Al, Si, and Ni. Bronzes are stronger and more corrosion resistant than brasses. Mention has to be made about beryllium coppers who possess a combination of relatively high strength, excellent electrical and corrosion properties, wear resistance, can be cast, hot worked and cold worked. Applications of Cu alloys include costume jewellery, coins, musical instruments, electronics, springs, bushes, surgical and dental instruments, radiators, etc.

**Magnesium Alloys:** The most sticking property of Mg is its low density among all structural metals. Mg has HCP structure, thus Mg alloys are difficult to form at room temperatures. Hence Mg alloys are usually fabricated by casting or hot working. As in the case of Al, alloys are cast or wrought type, and some of them are heat treatable. Major alloying additions are Al, Zn, Mn, and rare earth. Common applications of Mg alloys include hand-held devices like saws, tools, automotive parts like steering wheels, seat frames, electronics like casing for laptops, camcorders, cell phones, etc.

**Titanium Alloys:** Ti and its alloys are of relatively low density, high strength and have a very high melting point. At the same time, they are easy to machine and forge. However, the major limitation is Ti's chemical reactivity at high temperatures, which necessitated special techniques to extract. Thus these alloys are expensive. They also possess excellent corrosion resistance in diverse atmospheres and wear properties. Common applications include space vehicles, airplane structures, surgical implants, and petroleum and chemical industries.

**Refractory Metals:** These are metals of very high melting points. For example Nb, Mo, W, and Ta. They also possess high strength and high elastic modulus. Common applications include space vehicles, X-ray tubes, welding electrodes, and where there is a need for corrosion resistance.

### 17.5.3 Plastics

Common organic materials are plastics and synthetic rubbers, which are termed as organic polymers. Other examples of organic materials are wood, many types of waxes and petroleum derivatives. Organic polymers are prepared by polymerization reactions, in which simple molecules are chemically combined into long chain molecules or three-dimensional structures. Organic polymers are solids composed of long molecular chains. These materials have low specific gravity and good strength. The two important classes of organic polymers are:

- ▶ **Thermoplastics:** On heating, these materials become soft and hardened again upon cooling, e.g., nylon, polyethylene, etc.

- ▶ *Thermosetting Plastics:* These materials cannot be resoftened after polymerization, e.g., urea-formaldehyde, phenol formaldehyde, etc. Due to cross-linking, these materials are hard, tough, non-swelling and brittle. These materials are ideal for molding and casting into components. They have good corrosion resistance. The excellent resistance to corrosion, ease of fabrication into desired shape and size, fine lustre, light weight, strength, rigidity have established the polymeric materials and these materials are fast replacing many metallic components. PVC (Polyvinyl Chloride) and polycarbonate polymers are widely used for glazing, roofing, and cladding of buildings. Plastics are also used for reducing the weight of mobile objects, e.g., cars, aircraft, and rockets. Polypropylenes and polyethylene are used in pipes and manufacturing of tanks.

Thermoplastic films are widely used as lining to avoid seepage of water in canals and lagoons. To protect the metal structure from corrosion, plastics are used as surface coatings. Plastics are also used as main ingredients of adhesives. The lower hardness of plastic materials compared with other materials makes them subjective to attack by insects and rodents. Because of the presence of carbon, plastics are combustible. The maximum service temperature is of the order of 100°C. These materials are used as thermal insulators because of lower thermal conductivity. Plastic materials have a low modulus of rigidity, which can be improved by the addition of fillers, e.g., glass fibers. Natural rubber, which is an organic material of biological origin, is a thermoplastic material. It is prepared from a fluid, provided by the rubber trees. Rubber materials are widely used for tire of automobiles, insulation of metal components, toys and other rubber products.

**Timber:** Timber is general name of wood. It is composite of cellulose and lignin. Cellulose fibers are strong in tension and are flexible. Lignin works as a binding material to bind the fibers and give them stiffness. It has applications in many engineering works and has been used common construction materials. It has advantages over other engineering materials as easily available, strongest among cellular materials, easy processing, light weight, good surface finish, and inexpensive.

#### **17.5.4 Abrasive Materials**

Abrasives are hard, non-metallic, sharp-edged and irregular shaped materials used to remove a small amount of materials by cutting action. It may be used in bonded form or as free particles. It is employed in grinding, polishing, super finishing, buffing, honing operations. Commonly used abrasives are alumina ( $\text{Al}_2\text{O}_3$ ), Silicon carbide (SiC), Cubic boron nitride (CBN), and diamond.

#### **17.5.5 Ceramics**

Ceramics are compound of metallic and nonmetallic materials. It has properties of high compressive strength, low thermal expansion, high elasticity, high hardness, high wear

resistance, and low electrical and thermal conductivity. Ceramics are used for tiles, pottery, sanitary wares (Porcelain). The raw materials used for ceramics are clay having a fine sheet-like structure, Kaolin (silicate of aluminum) used as clay, flint, and feldspar.

### 17.5.6 Silica

It is available in abundance in nature in the form of quartz. Most of the glasses contain more than 50% of silica. It is also used in electric materials to increase the magnetic permeability of the materials. It may be used in the form of silicates of various materials as clay, asbestos, mica, glasses, etc.

### 17.5.7 Glasses

It is a super cooled amorphous material. It consists of more than 50% silica and other additives such as oxides of aluminum, sodium, calcium, magnesium, titanium, lithium, lead, and potassium. It has applications in windows, containers, lighting instruments, cookware, etc. The availability of various types of glasses is soda-lime glass, lead alkali glass, borosilicate glass, etc.

## RECAP ZONE .....



### Points to Remember

- **Tensile strength** enables the material to resist the application of a tensile force.
- **Shear strength** is the ability of a material to resist the shear force applied to the material.
- **Compressive strength** is the ability of a material to withstand pressures acting on a given plane.
- **Elasticity** is the property of material due to which it returns to its original shape and size after releasing the load.
- **Hardness** is the degree of resistance to indentation, scratching, abrasion, and wear. Alloying techniques and heat treatment help to achieve the same.
- **Ductility** is the property of a metal by virtue of which it can be drawn into wires or elongated before rupture takes place. It depends upon the grain size of the metal crystals.
- **Malleability** is the property of a metal to be deformed or compressed permanently into the sheet without fracture. It shows the ability of the material to be rolled or hammered into thin sheets.
- **Impact strength** is the energy required per unit cross-sectional area to fracture a specimen, i.e., it is a measure of the response of a material to shock loading.
- **Toughness** is the ability of the material to absorb energy before fracture or rupture. It may be presented as impact strength of the material.
- **Brittleness** implies sudden failure. It is the property of breaking without warning, i.e., without visible permanent deformation.
- **Wear resistance** is the ability of a material to resist friction wear under particular conditions, i.e., to maintain its physical dimensions when in sliding or rolling contact with a second member.
- **Hook's law** states that stress and strain are perpendicular to each other under the elastic limit.

- Originally, Hooke's law specified that stress was proportional to strain but Thomas Young introduction constant of proportionality, which is known as the Young Modules. Further, this was superseded by modules of elasticity.
- In ferrous materials, the main alloying element is carbon (C). Depending on the amount of carbon present, these alloys will have different properties, especially when the carbon content is either less/higher than 1.5%. Gray cast iron alloys consist carbon in form graphite flakes, which are surrounded by either ferrite or pearlite.
- The carbon content in cast iron varies between 2% and 4%.
- Organic polymers are prepared by polymerization reactions, in which simple molecules are chemically combined into long chain molecules or three-dimensional structures.
- On heating, **thermoplastics** become soft and hardened again upon cooling, e.g., nylon, polyethene, etc.
- **Thermosetting plastics** cannot be resoftened after polymerization, e.g., urea-formaldehyde, phenol-formaldehyde, etc.
- **Timber** is general name of wood. It is composite of cellulose and lignin. Cellulose fibers are strong in tension and are flexible. Lignin works as a binding material to bind the fibers and give them stiffness.
- **Ceramics** are compound of metallic and non-metallic materials. It has properties of high compressive strength, low thermal expansion, high elasticity, high hardness, high wear resistance, and low electrical and thermal conductivity.
- **Abrasives** are hard, non-metallic, sharp-edged, and irregular shaped materials used to remove a small amount of materials by cutting action.
- **Silica** is available in abundance in nature in the form of quartz.
- **Glass** is a super cooled amorphous material. It consists of more than 50% silica and other additives such as oxides of aluminum, sodium, calcium, magnesium, titanium, lithium, lead, and potassium.

## REVIEW ZONE .....



### Multiple-choice Questions

1. Ability of material to resist deformation due to stress is known as:
 

(a) Toughness	(b) Stiffness
(c) Plasticity	(d) Hardness
2. Ability of material to resist fracture due to high impact load is known as:
 

(a) Toughness	(b) Stiffness
(c) Plasticity	(d) Hardness
3. Ability of material to absorb energy in the plastic range is known as:
 

(a) Resilience	(b) Stiffness
(c) Plasticity	(d) Hardness
4. Ability of material to undergo large permanent deformation in tension is known as:
 

(a) Toughness	(b) Stiffness
(c) Ductility	(d) Hardness
5. Property of material due to which they can be drawn into wire is known as:
 

(a) Toughness	(b) Stiffness
(c) Ductility	(d) Hardness
6. Ability of material to retain permanent deformation is known as:
 

(a) Toughness	(b) Stiffness
(c) Plasticity	(d) Hardness
7. Property of material due to which it can be rolled or hammered into thin sheets is known as:
 

(a) Toughness	(b) Stiffness
(c) Malleability	(d) Hardness
8. Ability of material to resist penetration by another material is known as:
 

(a) Toughness	(b) Stiffness
(c) Plasticity	(d) Hardness

9. Hardness can be defined as resistance to:
- Wear
  - Local penetration
  - Scratching
  - All of the above
10. When a body recovers its original dimensions on removing the external load, it is known as:
- Elastic
  - Plastic
  - Brittle
  - None of these
11. Cast Iron is a:
- Ductile material
  - Malleable material
  - Brittle material
  - None of these
12. Silicon steel is widely used in:
- Cutting tools
  - Connecting rod
  - Electrical industry
  - Chemical industry
13. Thermosetting plastics are the materials that:
- Become soft on the application of heat and can be molded again
  - Do not become hard with the application of heat and pressure and no chemical change occurs
  - Set permanently with heat and pressure and cannot be deformed when again subject to heat
  - None of these
14. Thermoplastics are the materials that:
- Become soft on the application of heat and can be molded again
  - Do not become hard with the application of heat and pressure and no chemical change occurs
  - Set permanently with heat and pressure and cannot be deformed when again subject to heat
  - None of these
15. Moh's scale is used in connection with:
- The composition of the metal
  - The hardness of the material
  - Wear criterion of metals
  - The tensile strength of metals
16. An amorphous material is:
- Mica
  - Lead
  - Rubber
  - Glass
17. Polyesters belong to the group of:
- Thermoplastic
  - Thermosetting plastic
  - Phenolics
  - PVC
18. Brinell hardness number is equal to:
- $\frac{P}{D - \sqrt{D^2 - d^2}}$
  - $\frac{P}{D \left[ D - \sqrt{D^2 - d^2} \right]}$
  - $\frac{2P}{D - \sqrt{D^2 - d^2}}$
  - $\frac{2P}{\pi D \left[ D - \sqrt{D^2 - d^2} \right]}$
19. Vicker's Pyramid Number (VPN) is equal to:
- $\frac{2P \sin \theta}{d^2}$
  - $\frac{P \sin \theta}{d^2}$
  - $\frac{P \sin \theta}{d^2}$
  - None of these
20. Knoop Harness Number (KHN) is equal to:
- $\frac{P}{LC}$
  - $\frac{P}{L^2C}$
  - $\frac{2P}{LC}$
  - $\frac{2P}{L^2C}$
21. Composite materials are:
- Made mainly to improve temperature resistance
  - Used for improved optical properties
  - Made with strong fibers embedded in weaker and softer matrix to obtain strength better than the strength of matrix.
  - Made with strong fibers embedded in weaker and softer matrix to obtain strength better than the strength of both matrix and filler.
22. Ceramic materials are:
- Good conductors of electricity
  - Basically crystalline oxides or metals
  - Inorganic compounds of metallic and non-metallic elements
  - None of the above



## Answers

- |         |         |         |         |         |         |
|---------|---------|---------|---------|---------|---------|
| 1. (b)  | 2. (a)  | 3. (a)  | 4. (c)  | 5. (c)  | 6. (c)  |
| 7. (c)  | 8. (d)  | 9. (d)  | 10. (a) | 11. (c) | 12. (c) |
| 13. (c) | 14. (b) | 15. (b) | 16. (d) | 17. (b) | 18. (d) |
| 19. (c) | 20. (c) | 21. (c) | 22. (c) |         |         |

## Theory Questions

1. Explain the mechanical properties of engineering materials in brief.
2. Explain the experimental set up of tensile testing of steel.
3. Explain the methods to measure the hardness of a material.
4. How do you measure the toughness of a material? Explain the experimental methods used to measure the same.
5. Classify the engineering materials and explain the application and constituents of some of the important ferrous and non-ferrous materials.
6. Write short notes on: (i) Timber, (ii) composite materials, (iii) glass, and (iv) plastics.
- \*7. What are different classes of cast iron? What are their properties and applications?
- \*8. What is plain carbon steel? Give the classification of plain carbon steels and their important properties and uses.
- \*9. Define the following terms:
  - (i) Toughness, (ii) Hardness, (iii) Normalizing, and (iv) Case hardening.
- \*10. Define the following mechanical properties:
  - (i) Strength, (ii) Hardness, (iii) Ductility, and (iv) Toughness.
- \*11. Define elasticity, rigidity, hardness, fatigue, ductility, brittleness.
- \*12. Define ferrous and non-ferrous materials with their properties and suitable application.
- \*13. Enlist physical properties of engineering materials
- \*14. How can engineering materials be classified?
- \*15. What is ferrous metal? Write a note on stainless steel. Write down its application.
- \*16. Differentiate between ferrous and non-ferrous materials.
- \*17. Define composite materials, write down its practical applications.
- \*18. What is alloy? Write down its application.
- \*19. Explain applications of composites.
- \*20. Define composite material. How are composites classified?

\* indicates that similar questions have appeared in various university examinations.

## Learning Objectives

*By the end of this chapter, the student will be able:*

- To demonstrate the use of temperature measurement instruments
- To demonstrate the use of pressure measurement instruments
- To demonstrate the use of force measurement instruments
- To demonstrate the use of flow measurement instruments
- To demonstrate the use of linear and angular measurement instruments

### 18.1 ► INTRODUCTION

In order to produce components, the manufacturer has to know whether the components meet the required dimensional and accuracy standards. Companies carrying out maintenance activities also need to know that the components they are working with, repairing or servicing are to the required size and accuracy. Measurement plays an important role in establishing these needs and supports other areas of assuring quality in the products produced. The process of finding out whether a product is accurate and to dimensional standards also needs to be done in an efficient and effective way. The aim of this chapter is to provide a broad understanding of mechanical measurement that applies to a range of engineering applications such as measurement of temperature, velocity, flow, force, torque, strain, etc. Also, some tools for linear and angular measurements have been introduced in this chapter.

## 18.2 ► TEMPERATURE MEASUREMENT

Temperature of a body shows a degree of hotness with respect to reference body. There are a number of temperature measurement systems, some of them are: thermocouples, resistive temperature devices (RTDs and thermistors), infrared radiators, bimetallic devices, liquid expansion devices, and change-of-state devices, etc.

### 18.2.1 Thermocouple

When two conductors made from dissimilar metals are connected forming two common junctions and the two junctions are exposed to two different temperatures, a net thermal emf (electromagnetic force) is produced, the actual value is dependent on the materials used and the temperature difference between hot and cold junctions. The thermoelectric emf generated, in fact, is due to the combination of two effects: Peltier effect and Thomson effect. As temperature goes up, this output emf of the thermocouple rises (though not necessarily linearly).

### 18.2.2 Resistance Temperature Devices (RTD)

Resistive temperature devices works on the principle that the electrical resistance of material changes with its temperature. There are two key types of the devices: RTD and thermistors. It is well known that resistance of metallic conductors increases with temperature, while that of semiconductors generally decreases with temperature. Resistance thermometers employing metallic conductors for temperature measurement are called Resistance Temperature Detector (RTD), and those employing semiconductors are termed as Thermistors. As their name indicates, RTDs rely on resistance change in a metal, with the resistance rising more or less linearly with temperature. Thermistors are based on resistance change in a ceramic semiconductor; the resistance drops nonlinearly with temperature rise. The variation of resistance of metals with temperature is normally modeled in the form:

$$R_1 = R_0 [1 + \alpha (t - t_0)]$$

where  $R_0$  and  $R_1$  are resistance at temperature  $t$  and  $t_0$ , respectively.

### 18.2.3 Infrared Temperature Measurement Devices

Infrared sensors are non-contacting devices. They infer temperature by measuring the thermal radiation emitted by a material.

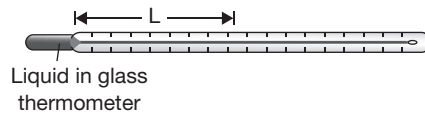
### 18.2.4 Bimetallic Temperature Measurement Devices

Bimetallic devices work on the principle that different materials have a different rate of thermal expansion. Strips of two metals are bonded together. When heated, one side will expand

more than the other, and the resulting bending is translated into a temperature reading by mechanical linkage to a pointer. These devices are portable and they do not require a power supply, but they are usually not as accurate as thermocouples or RTDs and they do not readily lend themselves to temperature recording.

### 18.2.5 Fluid-expansion Temperature Measurement Devices

Fluid-expansion devices can be divided into two main classes: the mercury type and the organic-liquid type. Versions employing gas instead of liquid are also available. Mercury is considered an environmental hazard, so there are regulations governing the shipment of devices. Fluid-expansion sensors do not require electric power, do not pose explosion hazards, and are stable even after repeated cycling. On the other hand, they do not generate data that is easily recorded or transmitted, and they cannot make spot or point measurements. A typical glass thermometer is shown in Figure 18.1.



**FIGURE 18.1**

Glass Thermometer

### 18.2.6 Change-of-state Temperature Measurement Devices

Change-of-state temperature sensors consist of labels, pellets, crayons, lacquers or liquid crystals whose appearance changes once a certain temperature is reached. They are used, for instance, with steam traps - when a trap exceeds a certain temperature, a white dot on a sensor label attached to the trap will turn black. Response time typically takes minutes, so these devices often do not respond to transient temperature changes and accuracy is lower than with other types of sensors.

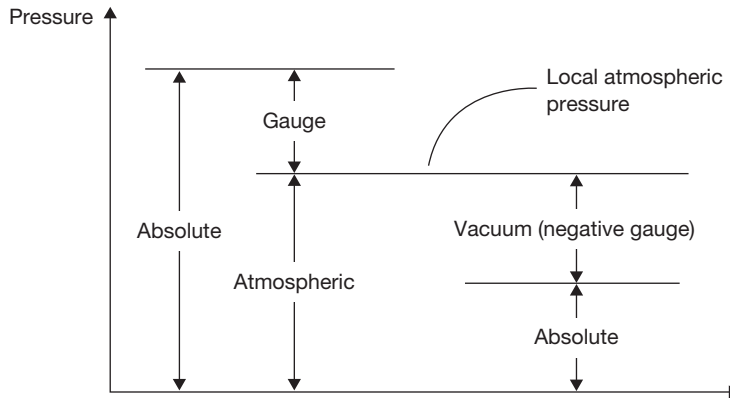
## 18.3 ► PRESSURE MEASUREMENT

Pressure is force per unit area on a surface. There are some relative terms such as gauge pressure, atmospheric pressure and absolute pressure those can be understood easily with the Figure 18.2.

**Gauge Pressure:** It is the pressure relative to atmospheric pressure. Gauge pressure is positive for pressures above atmospheric pressure and negative for pressures below it.

**Absolute Pressure:** It is the sum of gauge pressure and atmospheric pressure.

$$P_{abs} = P_{gauge} + P_{atmospheric}$$



**FIGURE 18.2**

Relative Terms of Pressure

### 18.3.1 Manometers

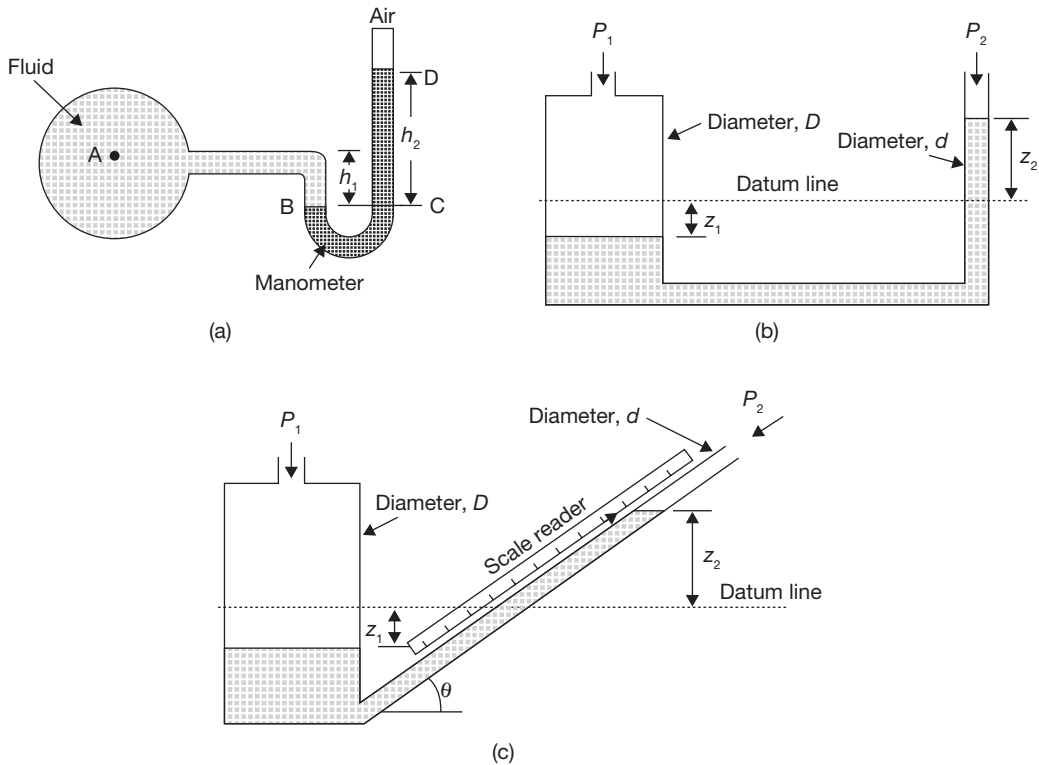
Manometers are differential pressure sensors. A differential pressure sensor measures the difference between a pressure being applied to it and a reference pressure (often atmospheric pressure). The U-tube manometer consists of a clear glass or plastic tube shaped into the form of a 'U'. The tube is partially filled with a liquid, such as water, alcohol, or mercury. The lower density of the liquid results in a higher sensitivity of the manometer. A pressure difference across the tube causes the liquid to shift position. The change in position can be measured to give the pressure. It is best suited to static pressure measurement. Difficult to use for small pressure changes, unsuitable for very large pressures.

In Figure (a), the pressure of the fluid can be measured as:

$$P = \rho g h_2; \quad \text{where } \rho \text{ is liquid density in manometer.}$$

In Figure (b), the pressure difference between two fluids can be measured as:

$$P_1 - P_2 = \rho g z_2; \quad \text{if } D \gg d$$


**FIGURE 18.3**

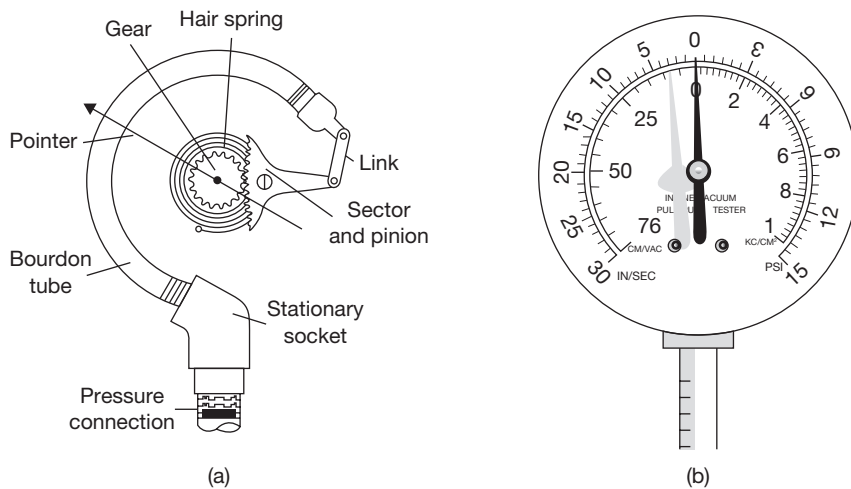
(a) Manometer Measuring the Pressure of a Fluid, (b) Manometer Measuring the Pressure Difference between Two Fluids, and (c) Inclined Tube Manometer

In Figure (c), The pressure of the fluid in Inclined manometer can be measured as:

$$P = \rho g z_2 = \rho g h \sin \theta$$

### 18.3.2 Bourdon Tube Pressure Gauge

The Bourdon tube pressure gauge, named after Eugène Bourdon, is a very popular pressure sensor. Basic Bourdon tubes are made from metal alloys such as stainless steel or brass. They consist of a tube of the elliptical or oval cross-section, sealed at one end. There are various shapes of Bourdon tube, including helical, spiral, and twisted. A common design is the C-shape, as shown in the Figure 18.4. When increased pressure is applied to the open end, it deflects outwards (tries to straighten) in proportion to the pressure inside the tube (the outside of the tube remains at atmospheric pressure). As the pressure is decreased, the tube starts to return to its atmospheric pressure position.

**FIGURE 18.4**

(a) Working of Bourdon Tube Pressure Gauge and (b) Bourdon Tube Pressure Gauge

The Bourdon tube pressure gauge, shown here, consists of a Bourdon tube connected to a pointer. The pointer moves over a calibrated scale. When pressure is applied, the movement of the tube is fairly small, so to increase the movement of the pointer it is mechanically amplified. This is usually by a connecting mechanism consisting of a lever, quadrant, and pinion arrangement.

### 18.3.3 Low Pressure Measurement

#### (a) Pirani Gauge

The Pirani gauge is a roughing pressure vacuum gauge. It uses the thermal conductivity of gases to measure pressure. The Pirani gauge head is based around a heated wire placed in a vacuum system, the electrical resistance of the wire is proportional to its temperature. At atmospheric pressure, gas molecules collide with the wire and remove heat energy from it (effectively cooling the wire). As gas molecules are removed (when the system is pumped down) there are fewer molecules and therefore fewer collisions. Fewer collisions mean that less heat is removed from the wire and so it heats up. As it heats up, its electrical resistance increases. A simple circuit utilizing the wire detects the change in resistance and, once calibrated, can directly correlate the relationship between pressure and resistance. This effect only works in the pressure region from the atmosphere to approx.  $10^{-3}$  mbar. Therefore other types of gauge (Ion Gauge) have to be used to measure pressures lower than this.

### (b) Ion Gauges

When operating below the Pirani gauge range, an ion gauge can be used to measure pressure. The ion gauge consists of three distinct parts; the filament, the grid, and the collector. The filament produces electrons by thermionic emission. A positive charge on the grid attracts the electrons away from the filament; they circulate around the grid passing through the fine structure many times until eventually, they collide with the grid. Gas molecules inside the grid may collide with circulating electrons. The collision can result in the gas molecule being ionized. The collector inside the grid is negatively charged and attracts these positively charged ions. Likewise, they are repelled from the positive grid at the same time. The number of ions collected by the collector is directly proportional to the number of molecules inside the vacuum system. By this method, measuring the collected ion current gives a direct reading of the pressure.

## 18.4 ► VELOCITY MEASUREMENT

### 18.4.1 Velocity Measurement of Fluid with Pitot Tube

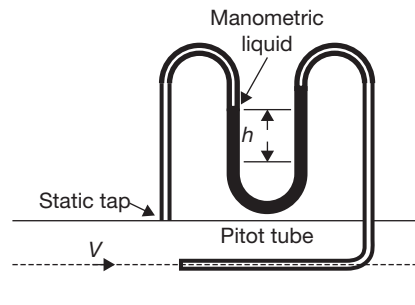
The arrangement for measuring fluid velocity using a Pitot tube is shown in Figure 18.5. The Pitot tube consists of a bent tube of small diameter with a rounded nose. The Pitot tube is connected to one limb of a U-tube manometer. The other limb of the manometer is connected to a tap made on the tube wall. The tube tap and the nose of the Pitot tube are roughly in the same plane. It is assumed that the wall tap senses the static pressure  $p$  of the fluid while the Pitot tube senses the stagnation pressure  $p_o$  of the fluid. From Bernoulli principle, we get

$$(p_o - p) = \frac{1}{2} \rho V^2$$

Where  $\rho$  is the density (constant in the case of low-speed flow) of the fluid whose velocity is being measured. In the case of gas flow, the temperature also needs to be measured since the density is a function of static pressure and temperature. With  $\rho_m$  as the density of the manometer liquid, the pressure difference is given by:

$$(p_o - p) = (\rho_m - \rho)gh = \frac{1}{2} \rho V^2$$

$$\text{Thus, } V = \sqrt{\frac{2(\rho_m - \rho)gh}{\rho}}$$



**FIGURE 18.5**

Velocity Measurement with Pitot Tube



### 18.4.2 Hot Wire Anemometer

A hot wire anemometer involves the heat that is dissipated by a hot wire to an ambient fluid passing it. For a fixed wire temperature, the heat dissipation from the wire will be larger with a larger velocity of the fluid. Alternately, for a fixed heat dissipation rate from the wire, the wire temperature will be smaller with a larger velocity of the fluid. Thus, a hot wire anemometer is a thermal device and the velocity information is converted to thermal either by temperature change or change in the heat dissipation rate information.

## 18.5 ► FLOW MEASUREMENT

Flow measurement is the quantification of the volume of fluid movement. Flow can be measured in a number of ways. Positive displacement flow meters accumulate a fixed volume of fluid and then count the number of times the volume is filled to measure flow. Other flow measurement methods rely on forces produced by the flowing stream as it overcomes a known construction, to indirectly calculate flow. Flow may be measured by measuring the velocity of fluid over a known area. The common types of flowmeters that find industrial applications can be listed as below:

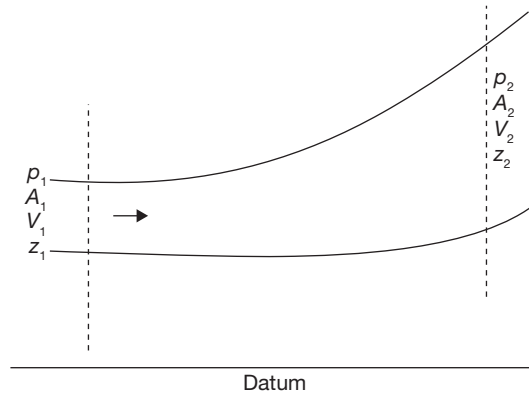
- (a) Obstruction type (differential pressure or variable area),
- (b) Inferential (turbine type),
- (c) Electromagnetic,
- (d) Positive displacement (integrating),
- (e) fluid dynamic (vortex shedding),
- (f) Anemometer,
- (g) ultrasonic, and
- (h) Mass flowmeter (Coriolis).

Obstruction or head type flowmeters are of two types: differential pressure type and variable area type. Orifice meter, Venturimeter, Pitot tube fall under the differential pressure type, while rotameter is of the variable area type. In all the cases, an obstruction is created in the flow passage and the pressure drop across the obstruction is related to the flow rate.

### 18.5.1 Flow Measurement Through Velocity of Fluid Over Known Area

Hydrodynamically, there are two types: laminar and turbulent. Whether a flow is viscous or turbulent can be decided by Reynold's number  $R_D$ . If  $R_D > 2,000$ , the flow is turbulent otherwise laminar. In the present case, we will assume that the flow is turbulent, that is the normal case for practical situations. Let us consider the fluid flow through a closed channel of variable cross section, as shown in Figure 18.6. Let the pressure, velocity, cross-sectional

area and height above the datum be expressed as  $p_1, v_1, A_1,$  and  $z_1$  for section 1 and the corresponding values for section 2 be  $p_2, v_2, A_2$  and  $z,$  respectively. We also assume that the fluid flowing is incompressible.



**FIGURE 18.6**

Turbulent Flow through a Channel

From Bernoulli's Equation

$$\frac{p_1}{\rho} + \frac{V_1^2}{2g} + z_1 = \frac{p_2}{\rho} + \frac{V_2^2}{2g} + z_2; \quad \text{where } \rho \text{ is the specific weight of the fluid.}$$

For  $z_1 = z_2$

$$\begin{aligned} \frac{p_1}{\rho} + \frac{V_1^2}{2g} &= \frac{p_2}{\rho} + \frac{V_2^2}{2g} \\ V_2^2 - V_1^2 &= \frac{2g(p_1 - p_2)}{\rho} \end{aligned}$$

Since flow is incompressible, hence  $v = A_1 V_1 = A_2 V_2 \Rightarrow V_1/V_2 = A_2/A_1$

Thus,

$$V_2^2 \left( 1 - \frac{V_1^2}{V_2^2} \right) = V_2^2 \left( 1 - \frac{A_2^2}{A_1^2} \right) = V_2^2 (1 - k^4) = \frac{2g(p_1 - p_2)}{\rho}$$

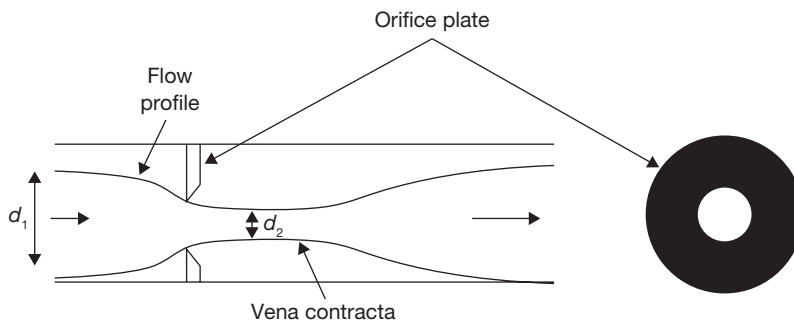
or

$$V_2 = \frac{1}{\sqrt{(1 - k^4)}} \sqrt{\frac{2g(p_1 - p_2)}{\rho}},$$

where  $k$  is ratio of diameters at section 2 and 1.

Volume of flow, 
$$Q = A_2 V_2 = \frac{A_2}{\sqrt{(1-k^4)}} \sqrt{\frac{2g(p_1 - p_2)}{\rho}}$$

### 18.5.2 Orificemeter



**FIGURE 18.7**

Orificemeter

In orificemeter, an orifice plate is placed in the pipeline, as shown in Figure 18.7. If  $d_1$  and  $d_2$  are the diameters of the pipeline and the orifice opening, then the flow rate can be obtained as:

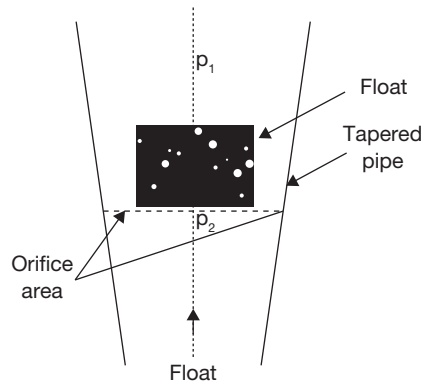
Volume of flow, 
$$Q = A_2 V_2 = \frac{C_d A_2}{\sqrt{(1-k^4)}} \sqrt{\frac{2g(p_1 - p_2)}{\rho}}$$

Where  $C_d$  is known as coefficient of discharge; its value ranges from 0.6 to 0.7.

### 18.5.3 Rotameter

The orificemeter and similar devices such as Venturimeter and flow nozzle work on the principle of constant area variable pressure drop. Here the area of obstruction is constant, and the pressure drop changes with flow rate. On the other hand, Rotameter works as a constant pressure drop variable area meter. It can be only be used in a vertical pipeline. Its accuracy is also less than the other types of flow meters. But it is simple in construction, ready to install and the flow rate can be directly seen on a calibrated scale, without the help of any other device, e.g. differential pressure sensor, etc.

The construction of a rotameter is shown in Figure 18.8. It consists of a vertical pipe, tapered downward. The flow passes from the bottom to the top. There is cylindrical type metallic float inside the tube. The fluid flows upward through the gap between the tube and the float. As the float moves up or down there is a change in the gap, as a result changing the area of the orifice. In fact, the float settles down at a position, where the pressure drop across the orifice will create an upward thrust that will balance the downward force due to the gravity. The position of the float is calibrated with the flow rate.



**FIGURE 18.8**

Rotameter

From orificemeter:

$$\text{Volume of flow, } Q = A_2 V_2 = \frac{C_d A_2}{\sqrt{(1-k^4)}} \sqrt{\frac{2g(p_1 - p_2)}{\rho}}$$

Let us consider the upward and downward forces on the float are  $F_u$  and  $F_d$  respectively. The apparent weight of float is  $W$ .

Now,

$$W = F_u - F_d$$

or

$$W = V_f (\rho_1 - \rho_2) = A_f (p_1 - p_2)$$

where  $\rho_1$  and  $\rho_2$  are specific weights of float and fluid.

$$\text{or, } p_1 - p_2 = \frac{V_f}{A_f} (\rho_1 - \rho_2)$$

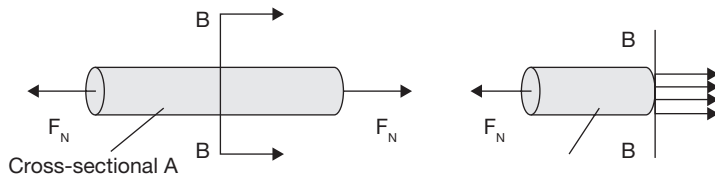
$$\text{Now, volume of flow, } Q = A_2 V_2 = \frac{C_d A_2}{\sqrt{\left(1 - \frac{A_2^2}{A_1^2}\right)}} \sqrt{\frac{2gV_f}{A_f} \left(\frac{\rho_1 - \rho_2}{\rho}\right)}$$

Here,

$$A_2 = A_{\text{throat}} - A_{\text{float}}$$

## 18.6 ► STRAIN MEASUREMENT

The proper design of load carrying components such as shafts, pressure vessels, and support structures for machines requires information about the distribution of forces within the particular component. The experimental analysis of stress is accomplished by measuring the deformation of a part under load and inferring the existing state of stress from the measured deflections.

**FIGURE 18.9**

Stress Analysis

Consider the rod in Figure 18.9. Stress is the internal distribution of force per unit area that balances and reacts to external loads applied to a body. If the rod has a cross-sectional area of  $A$ , and the load is applied only along the axis of the rod, the normal stress is defined as:

$$\sigma_a = \frac{F_N}{A}$$

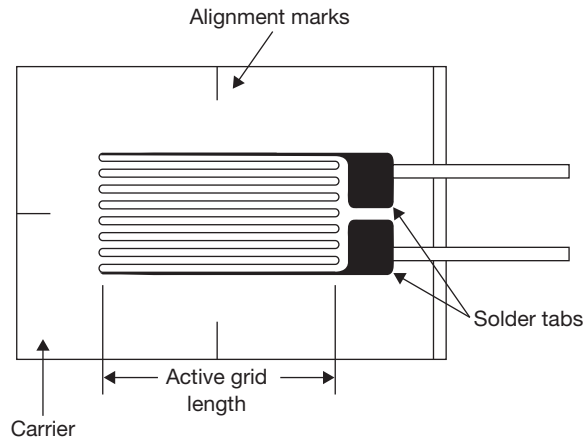
(The detail of stress-strain analysis has already been mentioned in Chapter 17, Article 17.3.1)

### 18.6.1 Strain Gauge

There are several methods of measuring strain; the most common is a strain gauge, a device whose electrical resistance varies in proportion to the amount of strain produced in the device. For example, the piezoresistive strain gauge is a semiconductor device whose resistance varies nonlinearly with strain produced. The most widely used gauge is the bonded metallic strain gauge. The metallic strain gauge consists of a very fine wire or, more commonly, metallic foil arranged in a grid pattern. The grid pattern maximizes the amount of metallic wire or foil subject to strain in the parallel direction (Figure 18.10).

The cross-sectional area of the grid is minimized to reduce the effect of shear strain and Poisson Strain. The grid is bonded to a thin backing, called the carrier, which is attached directly to the test specimen. Therefore, the strain experienced by the test specimen is transferred directly to the strain gauge, which responds with a linear change in electrical resistance. Strain gauges are available commercially with nominal resistance values from 30 to 3000  $\Omega$ , with 120, 350, and 1000  $\Omega$  being the most common values.

It is very important that the strain gauge is properly mounted onto the test specimen so that the strain is accurately transferred from the test specimen, through the adhesive and strain gauge backing, to the foil itself. Manufacturers of strain gauges are the best source of information on the proper mounting of strain gauges.

**FIGURE 18.10**

Bonded Metallic Strain Gauge

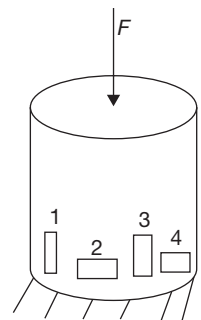
A fundamental parameter of the strain gauge is its sensitivity to strain, expressed quantitatively as the gauge factor (GF). Gauge factor is defined as the ratio of fractional change in electrical resistance to the fractional change in length (strain):

$$GF = \frac{\Delta R/R}{\Delta L/L} = \frac{\Delta R/R}{\epsilon}$$

The Gauge Factor for metallic strain gauges is typically around 2.

## 18.7 ► FORCE MEASUREMENT

**Load Cell:** Force can be measured easily from a load cell. Weighbridge is one of the most common applications of the load cell. Here two strain gauges are fixed so as to measure the longitudinal strain, while two other measuring the transverse strain, as shown in Figure 18.11. The strain gauges, measuring the similar strain (say, tensile) are placed in the opposite arms, while the adjacent arms in the bridge should measure opposite strains (one tensile, the other compression). If the strain gauges are identical in characteristics, this will provide not only the perfect temperature coefficient but also maximum obtainable sensitivity from the bridge.

**FIGURE 18.11**

Load Cell with Four Strain Gauges

The longitudinal strain developed in the load cell would be compression in nature and is given by:

$$\epsilon_1 = -\frac{F}{AE};$$

where  $F$  is the force applied,  $A$  is the cross-sectional area and  $Y$  is Young's modulus of elasticity.

The strain gages 1 and 3 will experience this strain, while for 2 and 4 the strain will be

The strain gages 1 and 3 will experience this strain, while for 2 and 4 the strain will be

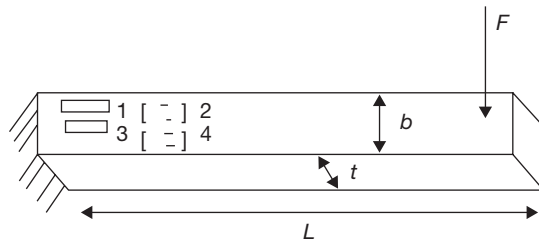
$$\epsilon_2 = -\frac{\nu F}{AE};$$

Where  $\nu$  is poisson's ratio.

### 18.7.1 Cantilever Beam

Cantilever beam can be used for measurement up to 10 kg of weight. One end of the cantilever is fixed, while the other end is free; the load is applied at this end, as shown in Figure 18.12. The strain developed at the fixed end is given by the expression:

$$\epsilon = \frac{6FL}{Ebt^2};$$



**FIGURE 18.12**

Cantilever Beam

- where  $l$  = Length of the beam
- $t$  = Thickness of the cantilever
- $b$  = Width of the beam
- $E$  = Young's modulus of the material

The strain developed can be measured by fixing strain gages at the fixed end: two on the top side of the beam, measuring tensile strain  $+\epsilon$  and two on the bottom measuring compression strain  $-\epsilon$  as shown in Figure 18.12. The elasticity of material ( $E$ ), length ( $L$ ), width ( $b$ ), thickness ( $t$ ) are already known; thus, after finding the strain using strain gauge we can calculate force  $F$ .

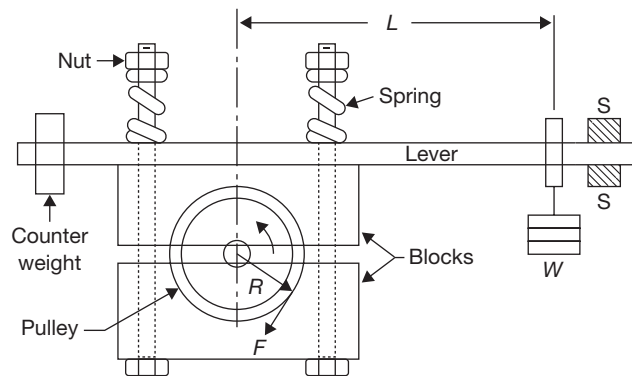
## 18.8 ► TORQUE MEASUREMENT

A torque is a vector product of force and radial distance that measures the tendency of a force to rotate an object about an axis or center. A dynamometer is a device for measuring mechanical force, or power, transmitted by a rotating shaft. Since power is the product of torque and angular speed, all power-measuring dynamometers are essentially torque measuring devices; the shaft speed is measured separately.

Power-measuring dynamometers may be transmission dynamometers or absorption dynamometers. The former utilize devices that measure torque, in terms of the elastic twist of the shaft or of a special torque-meter inserted between sections of the shaft. The torque is produced by the useful load that the prime mover, motor, or machine is carrying. Absorption dynamometers, on the other hand, produce the torque that they measure by creating a constant restraint to the turning of a shaft by either mechanical friction, fluid friction, or electromagnetic induction.

### 18.8.1 Prony Brake Dynamometer

A Prony brake (Figure 18.13) develops mechanical friction on the periphery of a rotating pulley by means of brake blocks that are squeezed against the wheel by tightening the bolts until the friction torque  $FR$  balances the torque  $WL$ .



**FIGURE 18.13**

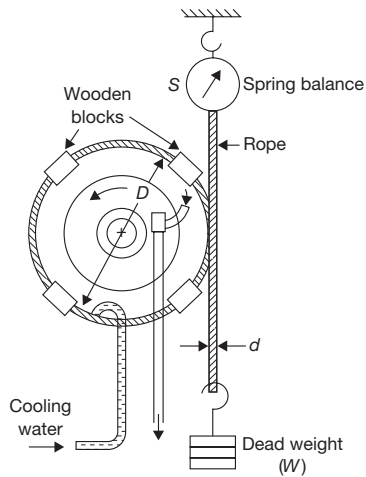
Prony Brake Dynamometer

$$\text{Torque, } T = F \times R = W \times L$$

### 18.8.2 Rope Brake Dynamometer

Rope brake dynamometer consists of a rope wound round the rim of the pulley fixed to the shaft of the engine whose torque is to be measured. The upper end of the rope is attached





**FIGURE 18.14**

Rope Brake Dynamometer

to a spring balance of stiffness  $S$  and the lower end of the rope is attached with a load  $W$  as shown in Figure 18.14. If the diameters of pulley and ropes be  $D$  and  $d$  respectively, the torque can be measured as:

$$T = (W - S) \frac{D + d}{2}$$

### 18.8.3 Torque Measurement by Pointer and Scale

Suppose the angle of twist on the shaft due to the application of torque  $T$  is  $\theta$ , which can be directly read by pointer and scale. The value of torque applied is directly related to the angle of twist as:

$$\theta = \frac{TL}{JG};$$

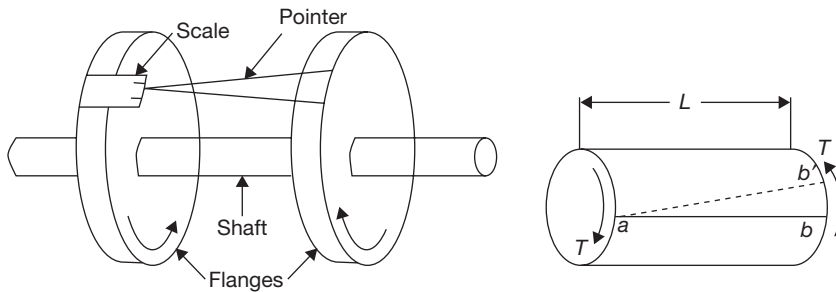
Where,  $L$  is the length of the shaft;

$J$  is polar moment of inertia; and

$G$  is modulus of rigidity of shaft material.

$J$  is function of shaft diameter

$$J = \frac{\pi d^4}{32}$$

**FIGURE 18.15**

Torque Measurement by Pointer and Scale

## 18.9 ► MEASUREMENT ERRORS

No measurement is exact. When a quantity is measured, the outcome depends on the measuring system, the measurement procedure, the skill of the operator, the environment, and other effects. Even if the quantity were to be measured several times, in the same way, and in the same circumstances, a different measured value would, in general, be obtained each time, assuming that the measuring system has sufficient resolution to distinguish between the values. The dispersion of the measured values would relate to how well the measurement is made. Their average would provide an estimate of the true value of the quantity that generally would be more reliable than an individual measured value. The dispersion and the number of measured values would provide information relating to the average value as an estimate of the true value. However, this information would not generally be adequate.

There are three types of errors which must be considered:

- (a) Spurious errors (human mistakes and instrument malfunctions)
- (b) Random errors (experimental and reading errors)
- (c) Systematic errors (which may be either constant or variable)

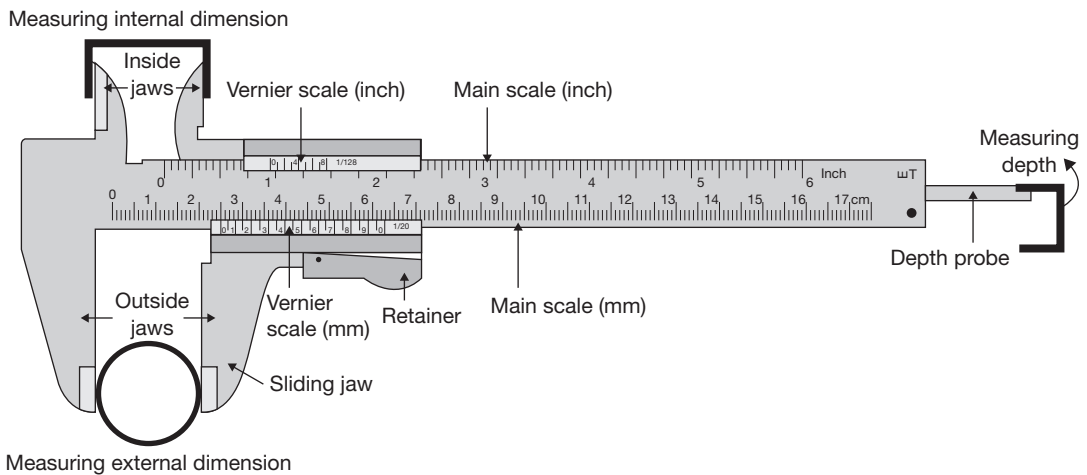
*Spurious errors* are errors which invalidate a measurement. They are like outliers. They cannot be incorporated into a statistical analysis. *Random errors* are an error that affects the reproducibility of the measurement. The mean random error of a summarized discharge over a period is expected to decrease when the number of discharge measurements during the period increases. Mean random error approaches zero over a long period of measurement. *Systematic errors* are errors which cannot be reduced by increasing the number of measurements. Whenever there is an evidence of a systematic error of a known sign, the mean error should be added or subtracted from the measured results.

## 18.10 ► UNCERTAINTIES OF MEASUREMENT

Uncertainty of measurement is the doubt that exists about the result of any measurement. You might think that well-made rulers, clocks, and thermometers should be trustworthy, and give the right answers. But for every measurement, even the most careful, there is always a margin of doubt. In everyday speech, this might be expressed as ‘give or take’, for example: a stick might be two meters long ‘give or take a centimeter’.

## 18.11 ► VERNIER CALIPERS

Vernier calipers are used for more accurate measurement than that of a slide caliper. It can measure internal and external dimensions, and it can also be used as a depth gauge and height gauge. Vernier calipers are available with metric and imperial graduations. A sample of vernier caliper is shown in Figure 18.16 with the name of different parts. Figure 18.16 also shows the ways of three different types of measurement such as measuring external dimension, internal dimension, and depth measurement.



**FIGURE 18.16**

Vernier Caliper

A vernier caliper consists of the main scale and vernier scale. Each division on the main scale is of 1 mm length. The vernier scale is 49 mm long and divided into 50 equal divisions. The length of each division on vernier scale is  $49/50$  mm. The difference between one division on main scale and one division on vernier scale is  $(1 - 49/50) = 1/50$  or 0.02 mm. To read the measurement, note the main scale measurement immediately preceding the zero line on vernier scale. For example, the zero of the vernier scale immediately precedes 40 mm. To this (40 mm) must be added the decimal reading on the vernier scale. Note the line on the vernier scale

which is exactly coincident with a line on the main scale. Suppose 10th line on vernier scale coincides with a line on the main scale. So the reading is 40 mm plus 10 divisions of 0.02 mm. Total length will be  $40 \text{ mm} + 10 \times 0.02 = 40.2 \text{ mm}$ . Thus, the measurement can be done as:

$$\text{Total length} = \text{Main Scale reading} + \text{Vernier Scale reading} \times \text{Least Count}$$

Precautions in use of vernier calipers:

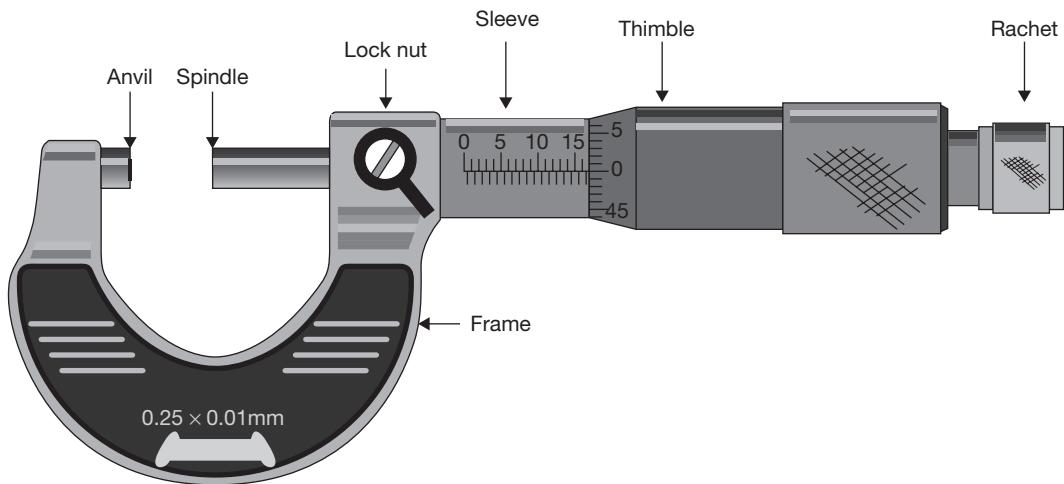
- (a) The following precautions must be taken in using the vernier calipers.
- (b) Store calipers in separate containers provided.
- (c) Keep graduations and markings on all calipers clean and legible.
- (d) Do not drop any caliper. Small nicks or scratches can cause inaccurate measurements.
- (e) Protect caliper points from damage.

## 18.12 ► MICROMETER OR SCREW GAUGE

A micrometer also known as a screw gauge is a device consist of a calibrated screw and used for precise measurement of small length. The first ever micrometric screw was invented by William Gascoigne in the 17th century, as an enhancement of the vernier; it was used in a telescope to measure angular distances between stars and the relative sizes of celestial objects. There may be three different types micrometers such as outside micrometer (used to measure wires, spheres, shafts, and blocks), inside micrometer (used to measure the diameter of holes), and depth micrometer measures (used to measure depths of slots and steps). Universal micrometer sets come with interchangeable anvils, such as flat, spherical, spline, disk, blade, point, and knife-edge. The term universal micrometer may also refer to a type of micrometer whose frame has modular components, allowing one micrometer to function as outside micrometer, depth micrometer, step micrometer, etc.

Micrometers use the principle of a screw to amplify small distances into large rotations of the screw that are big enough to read from a scale. The accuracy of a micrometer derives from the accuracy of the thread-form. The amount of rotation of the screw can be directly and precisely correlated to a certain amount of axial movement, through the constant known as the screw's lead. A screw's lead is the distance it moves forward axially with one complete turn ( $360^\circ$ ). With an appropriate lead and major diameter of the screw, a given amount of axial movement will be amplified in the resulting circumferential movement. For example, if the lead of a screw is 1 mm, but the major diameter (here, outer diameter) is 10 mm, then the circumference of the screw is  $10\pi$ , or about 31.4 mm. Therefore, an axial movement of 1 mm is amplified to a circumferential movement of 31.4 mm. This amplification allows a small difference in the sizes of two similar measured objects to correlate to a larger difference in the position of a micrometer's thimble.

In a micrometer, the position of the thimble is read directly from scale markings on the thimble and shaft as shown in Figure 18.17. A vernier scale is often included, which allows the position to be read to a fraction of the smallest scale mark.

**FIGURE 18.17**

Micrometer

A micrometer is composed of following components:

**Frame:** The C-shaped body that holds the anvil and barrel in constant relation to each other. It is thick because it needs to be rigid to minimize expansion and contraction, which may distort the measurement. The frame is heavy and consequently has a high thermal mass, to prevent substantial heating up by the holding hand/fingers. It is often covered by insulating plastic plates which further reduce heat transference. If we hold the frame long enough so that it heats up by  $10^{\circ}\text{C}$ , then the increase in the length of any 10 cm linear piece of steel is of magnitude  $1/100$  mm. For micrometers, this is their typical accuracy range. Micrometers typically have a specified temperature,  $20^{\circ}\text{C}$  [ $68^{\circ}\text{F}$ ], at which the measurement is correct.

**Anvil:** The shiny part that the spindle moves toward, and that the sample rests against.

**Sleeve or Barrel:** The stationary round part with the linear scale on it. Sometimes vernier markings.

**Lock Nut or Lock-ring:** The knurled part (or lever) that one can tighten to hold the spindle stationary, such as when momentarily holding a measurement.

**Screw:** This is known as the heart of the micrometer. It is inside the barrel.

**Spindle:** The shiny cylindrical part that the thimble causes to move toward the anvil.

**Thimble:** The part with graduated markings that one's thumb turns.

**Ratchet Stop:** Device on end of the handle that limits applied pressure by slipping at a calibrated torque.

### 18.12.1 Measurement Procedure

The spindle of an ordinary metric micrometer has 2 threads per mm, and thus one complete revolution moves the spindle through a distance of 0.5 mm. The longitudinal line on the frame is graduated with 1 mm divisions and 0.5 mm subdivisions. The thimble has 50 graduations, each being 0.01 mm (one-hundredth of a mm). Thus, the reading is given by the number of mm divisions visible on the scale of the sleeve plus the particular division on the thimble which coincides with the axial line on the sleeve.

Suppose that the thimble was screwed out so that graduation 8, and one additional 0.5 subdivision were visible (as shown in the image), and that graduation 32 on the thimble coincided with the axial line on the sleeve. The reading then would be  $8.00 + 0.5 + 0.32 = 8.82$  mm.

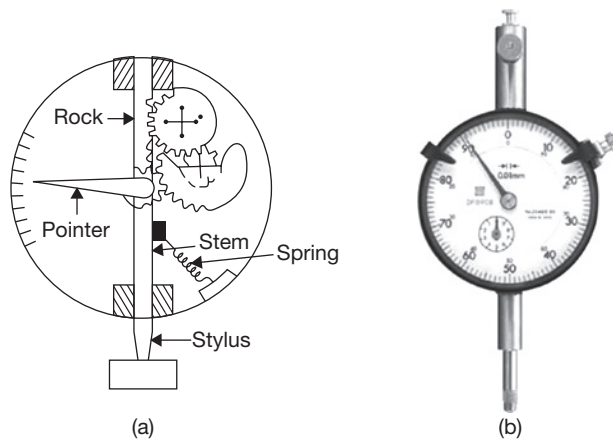
The spindle of an inch-system micrometer has 40 threads per inch, so that one turn moves the spindle axially 0.025 inch ( $1 \div 40 = 0.025$ ), equal to the distance between two graduations on the frame. The 25 graduations on the thimble allow the 0.025 inch to be further divided so that turning the thimble through one division moves the spindle axially 0.001 inch ( $0.025 \div 25 = 0.001$ ). Thus, the reading is given by the number of whole divisions that are visible on the scale of the frame, multiplied by 25 (the number of thousandths of an inch that each division represents), plus the number of that division on the thimble which coincides with the axial zero line on the frame.

## 18.13 ► DIAL GAUGE OR DIAL INDICATOR

The dial gauge or dial indicator consists of a small clock and a stylus probe as shown in Figure 18.18. Very small pressure on the stylus probe in upward direction results in rotation of pointer, i.e., the linear movement of the stylus is converted into angular movement of the pointer. Thus, this device is used to measure the linear vertical movement and to determine the errors in a geometrical form such as ovality, out of roundness, lobed form, taper, etc and the surface errors such as parallelism, squareness, alignment, etc. The dial is divided into 100 divisions. One complete revolution of the indicator corresponds to 1 mm linear movement of the stylus. Thus each division on the dial indicates a movement of 0.01 mm. The indicator is set to zero, initially, at a certain reference surface, and the instrument or the surface to be measured is brought into contact with a stylus. The movement of the indicator can be directly read from the dial.

## 18.14 ► SLIP GAUGES

Slip gauges are used as measuring blocks. It is also called as precision gauge blocks. They are made of hardened alloy steel of rectangular cross-section. The surfaces of slip gauges are made to a high degree of accuracy. The distance between the two opposite

**FIGURE 18.18**

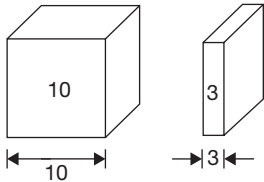
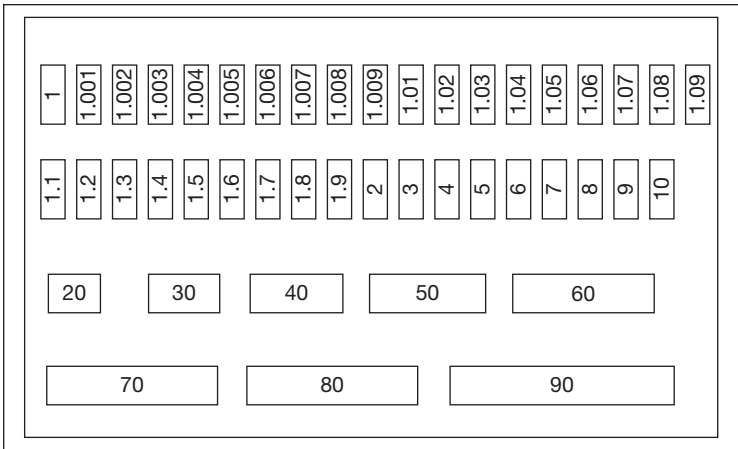
(a) Mechanism of Working of Dial Gauge and (b) Dial Gauge

faces indicates the size of the gauge. But all slip gauges are made to same thickness to perform wringing. Wringing or Sliding is nothing but combining the faces of slip gauges one over the other. Due to adhesion property of slip gauges, they will stick together. This is because of very high degree of surface finish of the measuring faces. They are used in comparators and sin bars. They are mainly used as a testing and calibrating instruments in metrology. Different sets of slip gauges are manufactured in standard sets of 32 pieces, 45 pieces, 88 pieces, etc. A set of 45 pieces of slip gauges is shown in Figure 18.19. A slip gauge set of 56 pieces is made up as follows: 9 slips 1.001 to 1.009 in steps of 0.001 mm; 9 slips 1.01 to 1.09 in steps of 0.01 mm; 9 slips 1.1 to 1.9 in steps of 0.1 mm; 25 slips 1 to 25 in steps of 1 mm; 3 slips 25 to 75 in steps of 25 mm; and one slip of 1.0005 mm.

### 18.14.1 Classification of Slip Gauges

Slip gauges are classified into various types according to their use as follows: (a) Grade 2, (b) Grade 1, (c) Grade 0, (d) Grade 00, and (e) Calibration grade.

- (a) Grade 2: It is a workshop grade slip gauges used for setting tools, cutters and checking dimensions roughly.
- (b) Grade 1: The grade I is used for precise work in tool rooms.
- (c) Grade 0: It is used as inspection grade of slip gauges mainly by inspection department.
- (d) Grade 00: Grade 00 mainly used in high precision works in the form of error detection in instruments.
- (e) Calibration grade: The actual size of the slip gauge is calibrated on a chart supplied by the manufacturer.



**FIGURE 18.19**

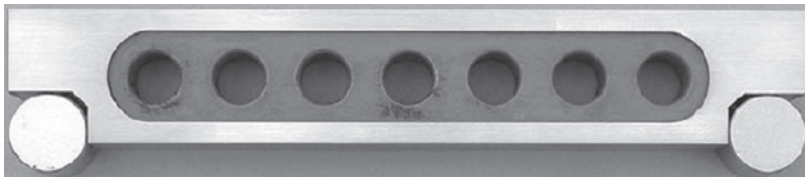
Slip Gauge Box with 45 Pieces of Slip Gauges

**18.14.2 Applications of Slip Gauge**

- (a) They are used in the tool room and machine shop for the calibration of precision measurements.
- (b) They are used in sine bars for measuring the angle.
- (c) They are used to set other measuring instruments such as snap gauges.
- (d) They can be used as auxiliary measuring system on a milling machine.

**18.15 ► SINE BAR**

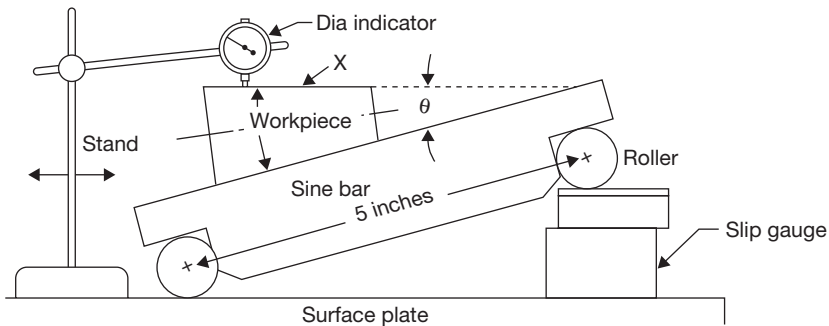
A sine bar is a tool used to measure angles of a block or metal working. It consists of a hardened steel body with two precision ground cylinders fixed at the ends. The distance between the centers of the cylinders is precisely controlled, and the top of the bar is parallel to a line through the centers of the two rollers as shown in Figure 18.20. The dimension between the two rollers is chosen to be a whole number and treated as the hypotenuse of a triangle.



**FIGURE 18.20**

Sine Bar



**FIGURE 18.21**

Sine Bar Measuring the Inclination Angle of a Workpiece

Generally, the center distance between two cylindrical rollers is 10 inch or 100 mm sine bar (however, 5-inch sine bar is also used).

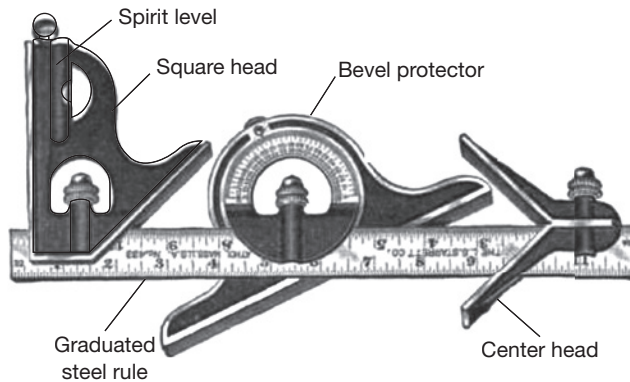
When a sine bar is placed on a flat surface, the top edge will be parallel to that surface. If one roller is raised by a certain distance using gauge blocks, then the top edge of the bar will be tilted by the same amount forming an angle that may be calculated by the application of the sine rule. Angles are measured using a sine bar with the help of gauge blocks and a dial gauge or a spirit level. For example, to measure the angle of a wedge, the sine bar is placed on a horizontal surface plate. The wedge is clamped over the sine bar with an inclined surface on the top. At this position, the top surface of the wedge is inclined with respect to surface plate. Using slip gauges, the top surface of the wedge is made horizontal. The sine of the angle of inclination of the wedge is the ratio of the height of the slip gauges used and the distance between the centers of the cylinders as shown in Figure 18.21

$$\sin \theta = \frac{h}{l};$$

where  $q$  is an inclination angle,  $h$  is height of slip gauges, and  $l$  is distance between rollers of sine bar.

### 18.16 ► COMBINATION SET

Combination set is a measuring tool which is frequently used in fitting and machine shop. It consists of a square head, center head, bevel protector, spirit-level, and graduated steel rule. Therefore it is known as a combination set as shown in Figure 18.22. The square head having two edges at  $90^\circ$  and  $45^\circ$  with steel rule can slide and is located at any position. This feature makes it possible to measure and mark the angle from  $45^\circ$  to  $90^\circ$  with respect to rule. Center head is used to determine the center of a round workpiece. It has two arms set at right angle to each other and is positioned on the graduated rule in such a manner that this angle is divided



**FIGURE 18.22**

Combination Set

into two equal parts by the edge of the rule. The angular measurement can be done by bevel protector attached with the graduated rule. It can be moved along the edge of steel rule and locked in any position. A spirit level is also used in combination set to check the level of the work with reference to scale edge.

## RECAP ZONE .....



### Points to Remember

- The **temperature** of a body shows a degree of hotness with respect to reference body.
- When two conductors made from dissimilar metals are connected forming two common junctions and the two junctions are exposed to two different temperatures, a net thermal emf (electromagnetic force) is produced, the actual value is dependent on the materials used and the temperature difference between hot and cold junctions.
- **Resistive temperature** devices work on the principle that the electrical resistance of material changes with its temperature.
- **Infrared sensors** are non-contacting devices. They infer temperature by measuring the thermal radiation emitted by a material.
- **Fluid-expansion devices** can be divided into two main classes: the mercury type and the organic-liquid type.
- **Pressure** is force per unit area on a surface.
- **Manometers** are differential pressure sensors. A differential pressure sensor measures the difference between a pressure being applied to it and a reference pressure (often atmospheric pressure).
- The **Bourdon tube pressure gauge**, named after Eugène Bourdon, is a very popular pressure sensor.
- The **Pirani gauge head** is based around a heated wire placed in a vacuum system, the electrical resistance of the wire is proportional to its temperature.

- > A **hot wire anemometer** involves the heat that is dissipated by a hot wire to an ambient fluid passing it.
- > **Flow measurement** is the quantification of the volume of fluid movement.
- > There are several methods of measuring strain; the most common is a strain gauge, a device whose electrical resistance varies in proportion to the amount of strain produced in the device.
- > Force can be measured easily from a load cell. Weighbridge is one of the most common applications of the load cell. Here two strain gauges are fixed so as to measure the longitudinal strain, while two other measuring the transverse strain.
- > A **torque** is a vector product of force and radial distance that measures the tendency of a force to rotate an object about an axis or center.
- > **Vernier calipers** are used for more accurate measurement than that of a slide caliper. It can measure internal and external dimensions, and it can also be used as a depth gauge and height gauge.
- > A **micrometer** also known as a screw gauge is a device consist of a calibrated screw and used for precise measurement of small length.
- > **Slip gauges** are used as measuring blocks. It is also called as precision gauge blocks. They are made of hardened alloy steel of rectangular cross-section. The surfaces of slip gauges are made to a high degree of accuracy.
- > A **sine bar** is a tool used to measure angles of a block or metal working.
- > **Combination set** is a measuring tool which is frequently used in fitting and machine shop. It consists of a square head, center head, bevel protector, sprit level and graduated steel rule.



## REVIEW ZONE .....

### Multiple-choice Questions

1. Which of the following equipment is not used for temperature measurement:
  - (a) RTD
  - (b) Thermister
  - (c) Gas thermometer
  - (d) Rotameter
2. Which of the following is correct:
  - (a)  $P_{abs} = P_{atmospheric} + P_{gauge}$
  - (b)  $P_{abs} = P_{atmospheric} - P_{gauge}$
  - (c) Both
  - (d) None of these
3. Manometer is used to measure:
  - (a) Pressure
  - (b) Velocity
  - (c) Flow
  - (d) Temperature
4. Which of the following is not used to measure pressure:
  - (a) Pirani gauge
  - (b) Ion gauge
  - (c) Bourdon gauge
  - (d) Slip gauge
5. Prony brake dynamometer is a type of:
  - (a) Transmission dynamometer
  - (b) Absorption dynamometer
  - (c) Electrical dynamometer
  - (d) None of these
6. Which of the following is the correct relationship:
  - (a)  $\theta = \frac{TL}{JG}$
  - (b)  $\theta = \frac{TG}{JL}$
  - (c)  $\theta = \frac{JG}{TL}$
  - (d)  $T = \frac{GL}{J\theta}$
7. The length measured by vernier caliper is:
  - (a) Total length = Main Scale reading  $\times$  Least Count + Vernier Scale reading
  - (b) Total length = (Main Scale reading + Vernier Scale reading)  $\times$  Least Count
  - (c) Total length = Main Scale reading + Vernier Scale reading  $\times$  Least Count
  - (d) Total length = Main Scale reading + Vernier Scale reading/Least Count
8. Sine bar is used to measure:
  - (a) The angle of a workpiece
  - (b) Radius of cylinder

- (c) Thickness of a job  
(d) All of the above
9. For the purpose of calibration of measuring instrument, which of the following is used:  
(a) Screw gauge  
(b) Slip gauge
- (c) Dial gauge  
(d) Ion gauge
10. Principle of working of micrometer is based on:  
(a) Screw (b) Bush  
(c) Coupling (d) Link

## Answers

1. (d)      2. (c)      3. (a)      4. (d)      5. (b)      6. (a)  
7. (c)      8. (a)      9. (b)      10. (a)

## Theory Questions

1. What are the various methods used for temperature measurement? Explain any one of them.
2. What is the principle of working of RTD? Explain the working.
3. What is the difference in principle of working of Orificemeter and rotameter? Discuss with applications
4. Explain the working of a manometer for pressure measurement.
5. Explain the principle of working of a thermocouple for temperature measurement.
6. Explain a process of velocity measurement of a fluid.
7. Explain the working of a load cell for force and strain measurement.
8. Explain the method of pointer and scale for torque measurement.
9. Discuss the application vernier caliper and its method of measurement.
10. Explain the principle of working of a micrometer.
11. Write short notes on: (a) Sin-bar, (b) Slip Gauge, (c) Combination set.

# Metal Cutting and Machine Tools

## Learning Objectives

*By the end of this chapter, the student will be able:*

- To understand the mechanism of metal cutting and different types of chip formation
- To demonstrate the working of lathe machine and the various operations performed on it
- To demonstrate the working of shaper, planer, and slotter machine with quick return mechanism
- To demonstrate the working of drilling and boring machines with their different applications
- To demonstrate the working of milling machines with application of different types of milling cutters
- To demonstrate the working of grinding machines and different types of grinding operations
- To demonstrate the different types of surface finishing processes

## 19.1 ► INTRODUCTION

Machine tools that give a shape to parts/products by removing metal chips from a workpiece include lathes, shapers, planers, drilling machines, boring machines, milling machines, grinders, etc. Before the Industrial Revolution of the 18th century, hand tools were used to cut and shape materials for the production of goods such as cooking utensils, wagons, ships, furniture, and other products. After the advent of the steam engine, material goods were produced by power-driven machines that could only be

manufactured by machine tools. Jigs and fixtures (for holding the work and guiding the tool) were the indispensable innovations that made interchangeable parts realities in the 19th century.

## 19.2 ► MECHANISM OF METAL CUTTING

The removal of extra material from a metal surface by shearing or cutting action is known as machining or metal cutting. The cutting takes place along a plane, which is known as a shear plane. There is a cutting zone; if it is examined carefully we find that the severe plastic deformation occurs in this zone due to a compressive force applied by the sharp edged cutting tool. The extra material due to this deformation flows over the tool surface, known as a chip, and this shearing zone is known as the primary shear zone.

During the flow of chip on the rake surface of the cutting tool, the temperature of newly formed chip increases due to friction and it gets welded automatically on the rake surface. But, due to a compressive force applied by newly formed chip (just after the welded chip) causes secondary shear of the welded chip, and this shear zone is known as the secondary shear zone. In metal cutting, the line generated by the cutting motion is called *generatrix* and the line formed by feed motion is called *directrix*.

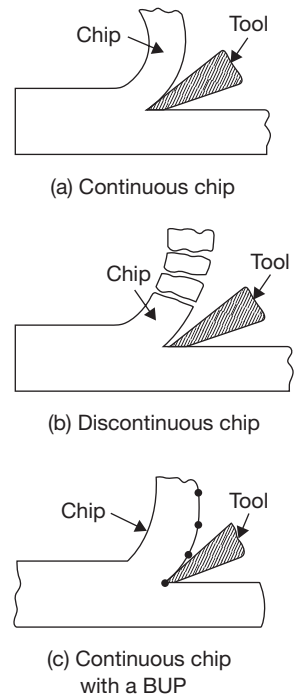
### 19.2.1 Types of Chip Formation

Various types of chips, which are formed in various cutting conditions and type of machining, can be categorized as:

- Continuous chip.
- Discontinuous chip.
- Continuous chip with a built-up edge.

**Continuous Chip:** Continuous chip as shown in Figure 19.1 (a), is formed due to:

1. Machining of ductile materials.
2. Small undercut thickness.
3. High cutting Speed.
4. Large rake angle of the tool.
5. Suitable cutting fluids.



**FIGURE 19.1**

Types of Chip Formation in Metal Cutting

**Discontinuous Chip:** Discontinuous chip as shown in Figure 19.1 (b), is formed due to:

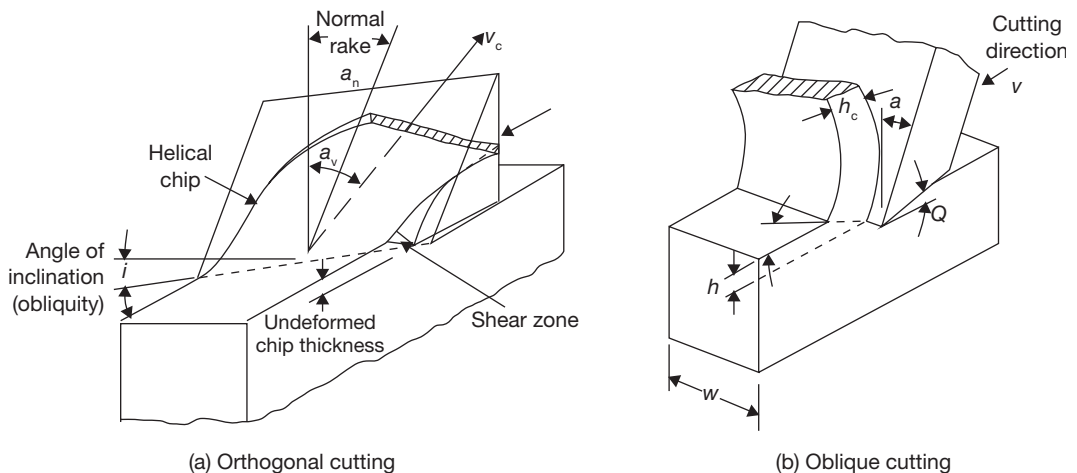
1. Machining of brittle work materials.
2. Low cutting speed.
3. Small rake angle.
4. Large uncut chip thickness.

**Continuous Chip with a Built-up (BUP) Edge:** Continuous chip with a built-up edge as shown in Figure 19.1 (c), is formed due to:

1. Large friction or stronger adhesion between chips and tool face.
2. Low rake angle.
3. Large uncut chip thickness.

### 19.3 ► ORTHOGONAL AND OBLIQUE METAL CUTTING

Orthogonal cutting is a machining process in which the cutting edge of the tool is kept perpendicular to the direction of the tool travel (Figure 19.2). But, in oblique cutting, the cutting edge of the tool is inclined at some acute angle to the direction of the tool travel. There are some fundamental differences in orthogonal and oblique cutting which are mentioned in Table 19.1.



**FIGURE 19.2**

Schematic View of Orthogonal and Oblique Cutting

Table 19.1: Differences between Orthogonal and Oblique Cutting

Orthogonal Cutting	Oblique Cutting
1. The cutting edge of the tool is perpendicular to the direction of the tool travel.	1. The cutting edge of the tool is inclined at some acute angle to the direction of the tool travel.
2. The cutting edge clears the width of the work piece on either end.	2. The cutting edge may or may not clear the width of the work piece on either end.
3. The chip flows over the rake surface of the cutting tool in the direction perpendicular to the cutting edge. The shape of the chip coil is tight flat spiral.	3. The chip flows on the rake surface of the tool making an angle with the normal on the cutting edge. The chip flows sideways in a long curl.
4. Only two components of the cutting force act on the cutting edge.	4. Three components of the forces mutually perpendicular acts at the cutting edge.
5. Maximum chip thickness occurs at the middle.	5. The maximum chip thickness may not occur at the middle.
6. For same feed and depth of cut, the force which shears the metal acts on a smaller area and therefore, the heat developed per unit area due to friction along the tool work interface is more and tool life is less.	6. Force of cutting acts on the longer area and therefore, the heat developed per unit area due to friction along the tool work interface is more and tool life is less.

## 19.4 ► LATHE

Lathe is the oldest machine tool. The entire machine tools are developed from the lathe, therefore, it is also known as the mother of machine tools. A number of cutting operations can be performed on a lathe with or without some attachments. On the lathe, a rotational motion is provided to the job and translational motion is provided to the cutting tool. Lathe machines can be classified on the basis of speed and purposes of applications.

### 19.4.1 Classification of Lathes

According to the construction and design lathe can be classified as follows:

- (a) **Bench Lathe:** It is small in size and mounted on a separate table. It has all the attachments, which a larger lathe has. It is used to perform a precise work.
- (b) **Speed Lathe:** This may be bench type or legs supported lathe. It has no gearbox, carriage, and lead screw. Therefore tool is actuated and fed by hand. This lathe is used for wood turning, polishing and spinning purposes.
- (c) **Engine Lathe:** This is the most widely used lathe. In early days, during the development phase of the lathe this lathe was driven by the steam engine, therefore named as engine lathe. Nowadays, all the engine lathes have separate engines or electric motors. Various speeds are achieved using cone pulley and gears.

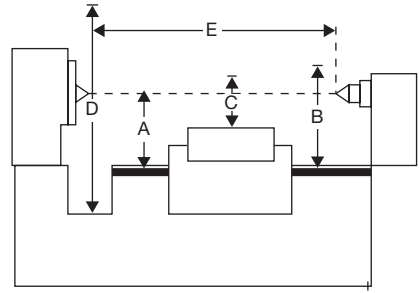


- (d) **Tool Room Lathe:** This is very similar to engine lathe but equipped with some extra attachments for more accurate and precise works. The usual attachments are taper turning attachment, follower rest, collets, chucks, etc.
- (e) **Capstan and Turret Lathes:** This is semi automatic type lathe and a wide range of operations can be performed on them. It can hold a large number of cutting tools compared to engine lathe.

### 19.4.2 Specifications of Lathe

Lathe machine can be specified by following dimensions (Figure 19.3):

- Height of center over bed (A)
- Maximum swing over bed (B)
- Maximum swing over carriage (C)
- Maximum swing in gap (D)
- Maximum length of work (E)



**FIGURE 19.3**

Specifications of Lathe

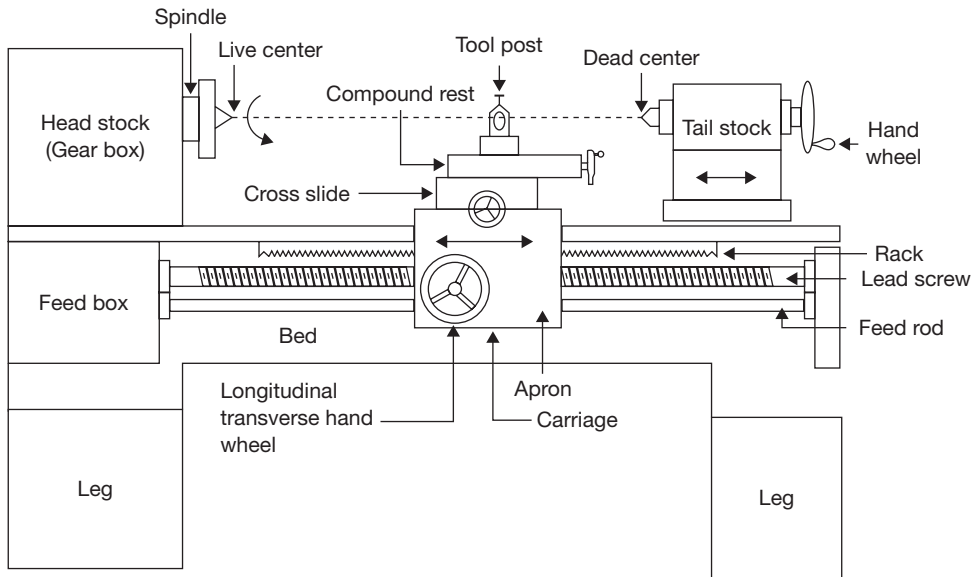
### 19.4.3 Constructional Detail of Lathe

A lathe machine consists of a number of components. These components perform various functions, for example, facilitate variation in speed, hold the cutting tool, rigidly hold the job, provide end support to the job, automatic movement of the tool, etc. A lathe with the nomenclature of various parts is shown in Figure 19.4.

**Bed:** All the fixed and moving parts of the lathe are mounted on the bed. It is made of cast iron in a single piece, it may be in two or three pieces for large size lathe, which are bolted together. It has v-ways for the collection of chips produced during machining. The carriage of the machine rests over the bed and slides on it. On the top of the bed, there are two sets of guide ways-inner ways and outer ways. The inner ways provide sliding surfaces for the tail stock and the outer ways for the carriage. The guide ways of the lathe bed may be flat and inverted V shape. Generally, cast iron alloyed with nickel and chromium material is used for manufacturing of the lathe bed.

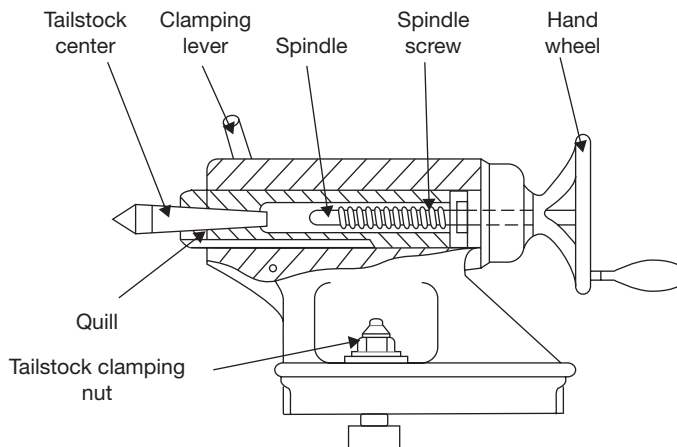
**Head Stock:** Head stock is the housing of cone pulleys, back gear, main spindle, live center, and feed reverse levers. It provides a driving mechanism to the job and tool post, carriage, apron, etc. The main function of head stock is to transmit power to the different parts of a lathe.

**Tail Stock:** The function of tail stock is to support the job at the end. It slides over the bed. It may have dead center or live center for point support to the job as per requirement. A tailstock is shown in Figure 19.5.



**FIGURE 19.4**

A Lathe with the Nomenclature of Its Parts



**FIGURE 19.5**

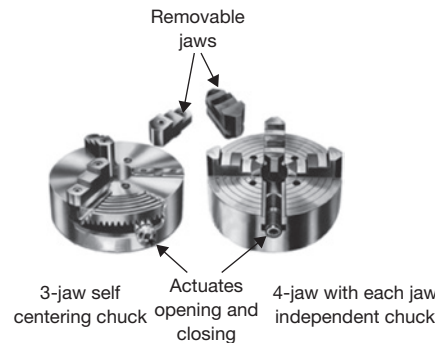
Tailstock of a Lathe

For tapping, drilling or boring, a tap or drill/boring tool may be used in place of dead center. The dead center moves forward or backward with the sleeve by rotating the hand wheel manually. Tail stock can be easily set or adjusted for alignment/nonalignment with respect to the spindle center and carries a center called dead center/live center for supporting one end of the work. Both live and dead centers have  $60^\circ$  conical points to fit center holes in the circular job, the other end tapering to allow for good fitting into the spindles. A live center or revolving center is constructed so that the  $60^\circ$  center runs in its own bearings and is used at the non-driven or tailstock end of a machine. A dead center (one that does not turn freely, i.e., *dead*) may be used to support the workpiece at either the fixed or rotating end of the machine. When used in the fixed position, a dead center produces friction between the workpiece and center, due to the rotation of the workpiece.

**Carriage and Tool Post:** It provides support to the tool post, cross slide, compound rest, apron, etc. The function of tool post is to hold cutting tool rigidly; tool post moves in the transverse direction on compound rest. The function of swivel plate is to give angular direction to the tool post whereas the function of cross slide is to give the linear motion to the tool by rotating the attached hand wheel. The apron is a hanging part in front of the carriage. It is the housing of gear trains and clutches. It gives automatic forward and reverse motion to the tool.

**Legs:** The legs provide rigid support to the entire machine tool. Both the legs are firmly secured to the floor by means of foundation bolts in order to prevent vibrations in the machine.

**Chucks:** The function of the chuck is to hold the job. There may be three-jaw or four-jaw chuck as shown in Figure 19.6. In three-jaw chuck, all the jaws move inwards or outwards simultaneously and there is no problem of centering hence it is also known as universal chuck. Whereas in four-jaw chuck each jaw moves independently. It may accommodate the irregular shape of the job but there is a problem of centering which is to be done manually. A magnetic chuck is also used to hold the job which works on the principle of electromagnetism.

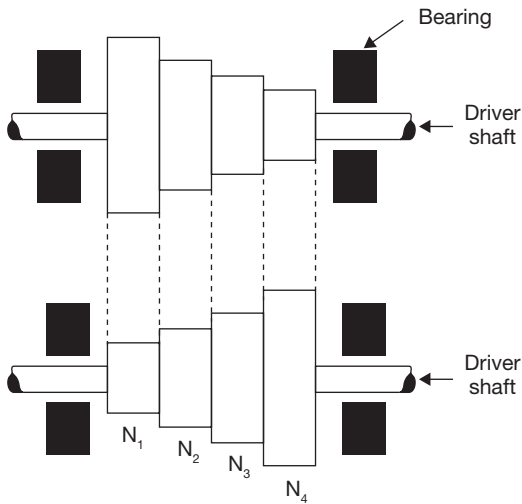


**FIGURE 19.6**

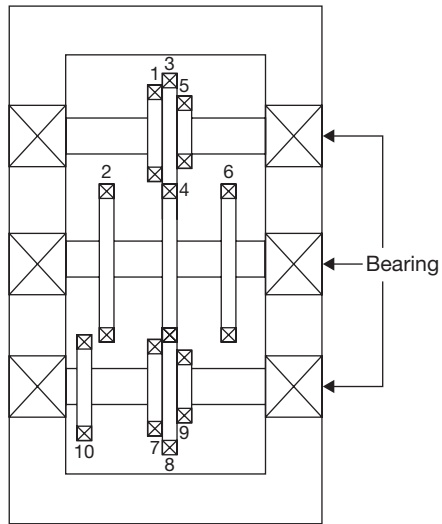
Three- and Four-jaw Chucks

#### 19.4.4 Power Transmission System in Lathe Machine

Head stock spindle drive system may include stepped or cone pulley drive or all geared head drive. In stepped pulley, the number of speed equals to the number of steps in the pulley. In all geared head drive, total nine various speed can be achieved.


**FIGURE 19.7**

Stepped Cone Pulley Drive


**FIGURE 19.8**

A Constructional Detail of All Geared Head Drive

**Stepped Pulley (Cone Pulley) Drive:** V-belt is used to transmit the power from driver shaft to spindle shaft. In 4-stepped pulley drive, four different speed of the head stock can be attained. Spindle speeds are varied in arithmetic progression (Figure 19.7).

Let driver shaft rotates at the speed of  $N$  rotation per minute (rpm) and the steps diameters of the pulley are  $D_1$ ,  $D_2$ ,  $D_3$ , and  $D_4$ . Driven shaft has pulley of same steps diameters but in reverse order, as shown in Figure 19.10. We know the speed is inversely proportional to the diameter, therefore,

$$\frac{N_1}{N} = \frac{D_4}{D_1}, \quad \frac{N_2}{N} = \frac{D_3}{D_2}, \quad \frac{N_3}{N} = \frac{D_2}{D_3}, \quad \frac{N_4}{N} = \frac{D_1}{D_4}$$

Where  $N$  is the speed of driver shaft and  $N_1$ ,  $N_2$ ,  $N_3$ ,  $N_4$  are speeds of the spindle shaft. Here  $D_1 < D_2 < D_3 < D_4$ .

**All Geared Head Drive:** This drive comprises of nine gears on three shafts. By operating two levers attached to two cluster gears on pulley shaft and head stock main spindle respectively, nine speeds can be obtained. Three gears 2-4-6 are fixed on the intermediate shaft. Spur gear (10) is fixed on the head stock spindle to transmit power to the feed shaft and lead screw. The constructional detail of all geared head drive is shown in Figure 19.8.

The gear combinations for nine different speeds are given below:

$$\begin{array}{ccc} \frac{T_1}{T_2} \times \frac{T_2}{T_7}; & \frac{T_1}{T_2} \times \frac{T_4}{T_8}; & \frac{T_1}{T_2} \times \frac{T_6}{T_9} \\ \frac{T_3}{T_4} \times \frac{T_2}{T_7}; & \frac{T_3}{T_4} \times \frac{T_4}{T_8}; & \frac{T_3}{T_4} \times \frac{T_6}{T_9} \\ \frac{T_5}{T_6} \times \frac{T_2}{T_7}; & \frac{T_5}{T_6} \times \frac{T_4}{T_8}; & \frac{T_5}{T_6} \times \frac{T_6}{T_9} \end{array}$$

where  $T_1, T_2, T_3, T_4, T_5, T_6, T_7, T_8,$  and  $T_9$  are number of teeth on gear 1, 2, 3, 4, 5, 6, 7, 8 and 9, respectively.

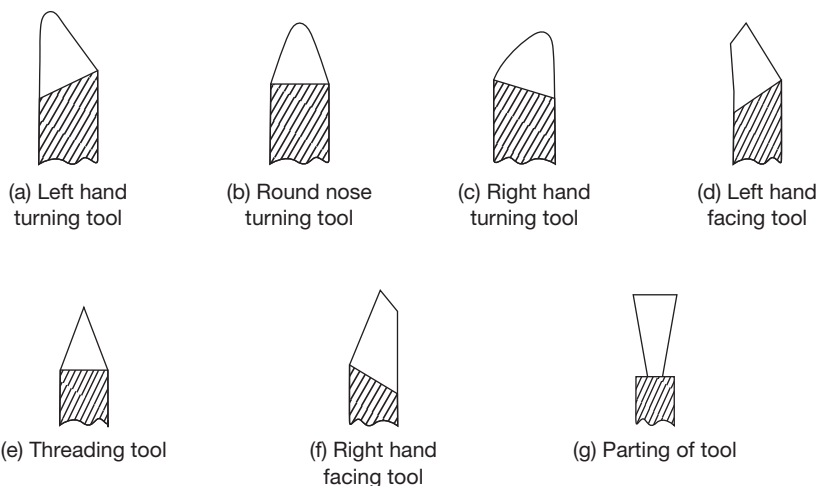
### 19.4.5 Cutting Tools Used in Lathe

A number of cutting operations are performed on a lathe machine. Therefore, various cutting tools are used in a lathe such as left hand and right hand turning tools, facing tools, threading tools, parting-off tool, etc., as shown in Figure 19.9.

### 19.4.6 Types of Operations on Lathe Machine

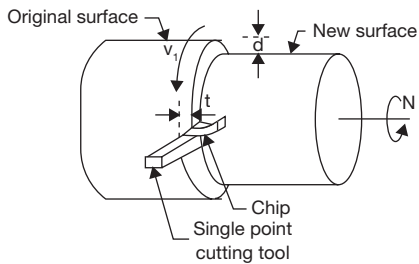
Following are the various types of operations performed on the lathe machines:

- (a) Turning, (b) Threading, (c) Tapping, (d) Drilling and boring, (e) Reaming, (f) Knurling,
- (g) Facing, (h) Parting, (i) Spinning.

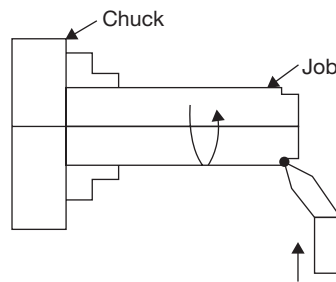


**FIGURE 19.9**

Various Cutting Tools Used in Lathe


**FIGURE 19.10**

Straight Turning on Lathe


**FIGURE 19.11**

Face Turning on Lathe

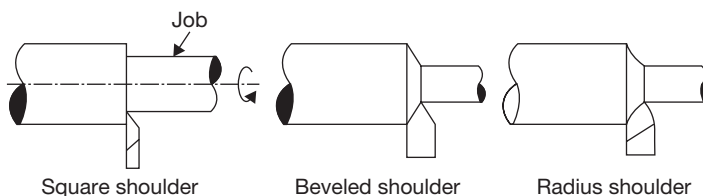
**Turning:** Turning is a metal removal process in which job is given rotational motion while the cutting tool is given linear (feed and depth of cut) motion. Different types of turning operations are mentioned below:

**Straight Turning:** It is the operation of producing a cylindrical surface of a job by removing excess material. In this operation, the job rotates and the tool is fed longitudinally by giving the desired depth of cut (Figure 19.10).

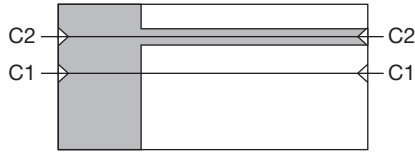
**Face Turning or Facing:** It is also known as facing operation. It is the operation of making the ends of a job to produce a square surface with the axis of operation or to make a desired length of the job. In this operation, job rotates and the tool advances in a perpendicular direction to the axis of the job rotation (Figure 19.11).

**Shoulder Turning:** If a job is turned with different diameters, the steps for one diameter to the other so formed, the surface is known as shoulder turning. There are several types of shoulder turning such as square, radius, beveled, etc., as shown in Figure 19.12. It is also known as step turning.

**Eccentric Turning:** When a job having more than one axis of rotation, each axis may be parallel with each other but never coincides, turning of different cylindrical surfaces of the job is known as eccentric turning. In Figure 19.13, the job is first turned through centers  $C_1-C_1$  and then through centers  $C_2-C_2$ .

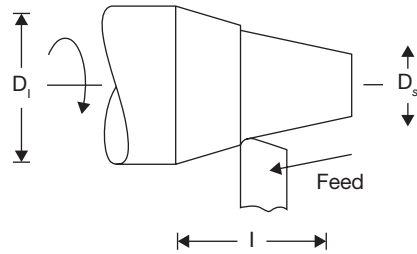

**FIGURE 19.12**

Shoulder Turning on Lathe



**FIGURE 19.13**

Eccentric Turning on Lathe



**FIGURE 19.14**

Taper Turning on Lathe

**Taper Turning:** Taper turning is an operation in which taper cylindrical surface, i.e., cone type surface is produced as shown in Figure 19.14.

Taper on a cylindrical surface of a job can be produced by the following methods:

**Taper Turning by Swiveling Compound Rest:** Job rotates on lathe axis and tool moves in the angular path. It can be applied from any angle 0-90 degree, a short length of taper up to 150 mm approximate  $\tan \alpha = \frac{D_1 - D_s}{2l}$ . It is used for shorter length and steeper angle. Here,  $D_1$  and  $D_s$  are larger and shorter diameters, and  $l$  is the length of the job.

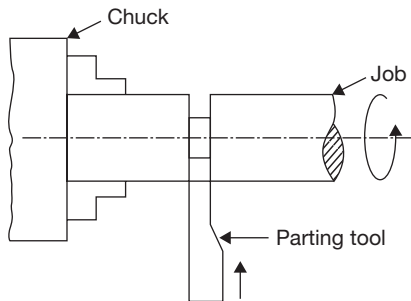
**Taper Turning by Offsetting the Tailstock:** Job rotates at an angle to the lathe axis and the tool travels longitudinally to the lathe axis. Any angle 0 to 8°, long job of smaller diameter can be turned by this method. It is also used for internal taper turning.

**Taper Turning Attachment:** Job rotates on lathe axis and tool moves in guided angular path. Any angle 0–12°, long jobs of steeper angle of taper can be done by this attachment. The guide rail is set as per angle of taper. It is applied for longer jobs of steep angle in mass production.

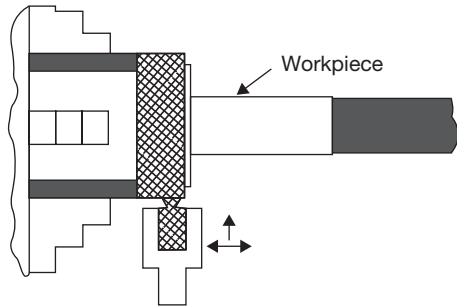
**Taper Turning by a Form Tool:** Job rotates on lathe axis and tool moves crosswise direction, perpendicular to the lathe axis. The very small length of taper and any angle 0–90°. The tool itself designed as per requirements. It is used for mass production for Chamfering on bolts, nuts, bushes, etc.

**Taper Turning by Combination Fed:** Job rotates on lathe axis and tool travels on the resultant path, for any length and any angle. The taper angle is to be determined by trial and error method. It is applied by hand feeds for making the ball of a hammer, by power feeds for production work.

**Parting-off (Grooving):** It is the operation of cutting-off/grooving a bar after it has been machined to the required shape and size. In this operation, the job is held on a chuck, rotates to the turning speed and the parting-off tool is fed into the job very slowly until the tool reaches to the center of the job. The parting-off operation is shown in Figure 19.15.


**FIGURE 19.15**

Parting-off Operation on Lathe

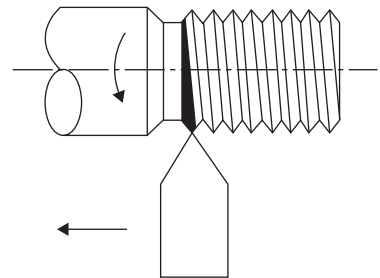

**FIGURE 19.16**

Knurling Operation on Lathe

**Knurling:** Knurling is the process of embossing, producing a roughened surface on a smooth surface of a cylindrical job to provide effective gripping, for example, thimble and ratchet of micrometer and plug gauge handle. Knurling tools (single, two or three sets of rollers) are held rigidly on tool post, pressed against the rotating (one-third speed of the turning) surface of a job, leaving exact facsimile of the tool on the surface of the job as shown in Figure 19.16.

### Thread Cutting

For thread cutting on the lathe, there is a definite relationship between the speeds of the job and tool. The relationship is obtained by gear ratio which selection depends on the pitch of the job, the pitch of the lead screw, number of the start of the thread on the job. Every machine is supplied with a spur gear box (a set of 23 gears) having teeth from 20 to 120 with an interval of 5 and a special gear or transfer gear is of 127 teeth for cutting the metric thread. Two 20 teeth spurs are available. Lead screw has single start thread. The simple process of thread cutting on the lathe is shown in Figure 19.17.


**FIGURE 19.17**

Thread Cutting on Lathe

### Steps for Thread Cutting on Lathe

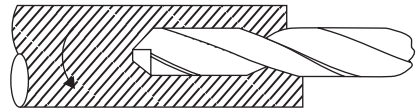
1. Hold the job on the machine and turn up to the major diameter of the thread.
2. Choose suitable thread cutting tool.
3. Select slower speed of the lathe spindle.
4. Calculate the change gear ratio based on the following formula:

$$\text{Change gear ratio} = \frac{\text{Pitch of the job} \times \text{No. of start}}{\text{Pitch of the lead screw}}$$



5. Fix the calculated change gear ratio to the head stock spindle, intermediate shaft and lead screw shaft.
6. Choose suitable depth of cut. Three or four cuts are necessary to complete the thread.
7. Arrange job and tool proper position and give desired depth of cut.
8. Engage half nut with respect to chasing dial according to odd/even threads.
9. Allow the movement of the tool up to the portions of the job necessary for thread cutting then lifting the tool from the job.
10. Disengage the half nut, move the carriage to the right side up to the position from where the second cut will start. Allowing the second depth of cut again engage the half nut with respect to chasing dial.

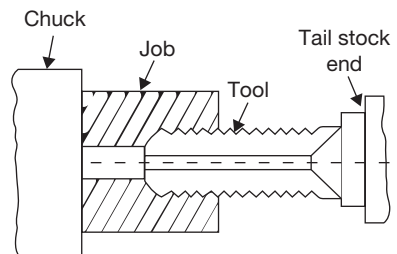
**Drilling:** The operation of producing a circular hole by removing metal by rotation the cutting edges of a drill is known as drilling. But on lathe drill is static and only feed motion is given through the movement of tail stock and rotating motion is given to the job. Metal is removed by shearing and extrusion. Drilled hole will be slightly oversized than the drill used due to the non-alignment of the drill and vibration of the spindle. For producing an accurate hole, the drill bit should be chosen slightly undersize and subsequent reaming or boring operation is essential after drilling. Drilling on the lathe is very easy. The drill bit is held in tail stock in place of dead center and moved in the forward direction applying pressure at the end of the rotating job. Drill moves up to the length of the hole required as shown in Figure 19.18.



**FIGURE 19.18**

Drilling on Lathe

**Tapping:** Tapping is an operation for producing internal thread. A hole of minor diameter is produced in the job by holding the drill tool in tail stock and applying pressure on the rotating job in chuck. After drilling the hole, the tap is held in tail stock and inserted in drilled hole of the rotating job as shown in Figure 19.19.

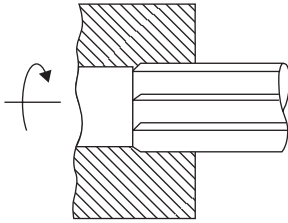


**FIGURE 19.19**

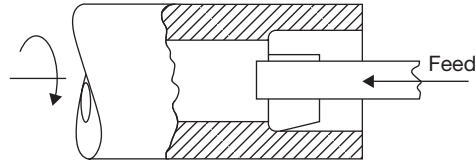
Tapping on Lathe

**Reaming:** The operation of finishing and sizing a previously drilled hole using a multi-edges straight cutting tool named as a reamer is known as reaming operation. Very small amount of material (0.4mm) removal is possible by this operation. Reaming operation is on lathe is very similar to drilling on the lathe as shown in Figure 19.20.

**Boring:** The operation of enlarging and finishing a previously drilled hole throughout its length by means of an adjustable single edge cutting tool named as boring tool is known as boring. Boring on the lathe is also very similar to drilling but this process is used to enlarge the drilled hole as shown in Figure 19.21.

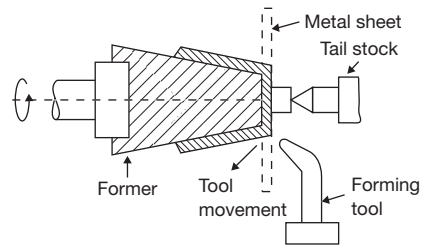
**FIGURE 19.20**

Reaming on Lathe

**FIGURE 19.21**

Boring on Lathe

**Spinning:** Spinning is a process to produce a circular homogeneous pot or house hold utensil. In this operation, the sheet metal job is held between a former attached with headstock spindle and the tail stock center and rotates at high speed with the former. The long round nose forming tool fixed rigidly on special tool post presses the job on the periphery of the former as shown in Figure 19.22. Thus the job is deformed exactly in the shape of former and the operation is known as spinning. It is chip-less machining process.

**FIGURE 19.22**

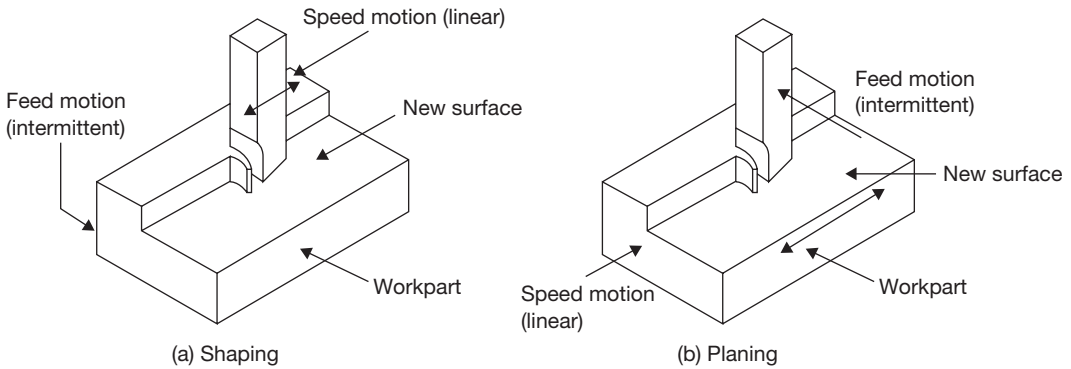
Spinning on Lathe

## 19.5 ► SHAPER, SLOTTER, AND PLANER

Shaper and planer are very old machine tools. They are used to produce a plane surface, inclined surface, and slots. But due to consumption of excess time, they are replaced by milling machines in large production. In a shaper, the cutting tool is provided reciprocation motion and job is provided only feed motion. Normally, forward stroke is a cutting stroke and backward or reverse stroke is idle stroke. During the backward stroke, the job is given feed motion. In a planer, the table job is given reciprocating motion and the tool is given feed motion. Planer is most suitable for the larger job which cannot be accommodated on the shaper.

### 19.5.1 Shaping and Planing

Shaping and planing are the oldest methods of machining. They are seldom used in production and have been replaced by milling and broaching. The major difference between these two processes is that, in shaping the reciprocating or cutting motion is provided to the tool and the feed is given to the workpiece, whereas in planing, it is just opposite (Figure 19.23). A single point cutting tool is used in both processes. The cutting takes place only in the forward stroke;



**FIGURE 19.23**

Shaping and Planing

the feed is given to the workpiece in return stroke. This operation is neither efficient nor economical. Shapers are more suitable for smaller workpieces than the planers. In addition to plain flat surfaces, the shapers most commonly produced on the shaper and planer include grooves, T-slot, and dovetails.

### 19.5.2 Constructional Detail of Shaper

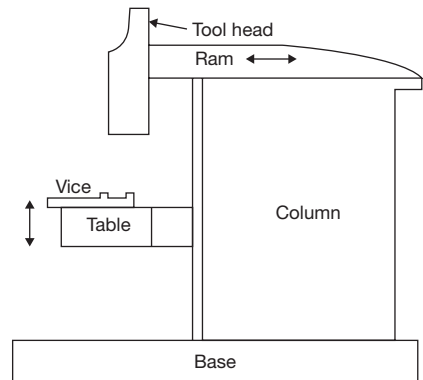
Constructional detail of shaper is shown in Figure 19.24. There are following parts of the shaper machine.

**Base:** Base is made of gray cast iron to absorb the vibration and it is bolted to shop floor.

**Column:** It is the housing of ram, quick return mechanism, and table. A ram reciprocates on the top of the column through two machined guide-ways and table can move up and down through cross-rail on the front of the vertical face of the column.

**Table:** It is a cast iron body, provided with T-slots to clamp the job, fixtures, etc., the table can move up and down and also it can be tilted in universal type shaping machine.

**Ram:** It carries a tool head on its front end. It reciprocates on horizontal guide-ways of the machine on the top of the column across the work. The motion of the ram is obtained by quick return mechanism. It cuts only in the forward stroke and moves faster in the backward or return stroke.



**FIGURE 19.24**

Constructional Details of Shaper

**Tool Head:** It is fixed at the front end of the ram. It consists of tool post, clapper box, down feed screw. Tool slide can be swiveled for the shaping of bevels, angular cuts, etc. The clapper box hinges on a pin in order to allow the tool to swing up during the return stroke. Down feed screw may be operated by hand or power for required depth of cut and down feed cutting.

**Cross-rail and Saddle:** Cross-rail slides up and down for positioning of the table over the front vertical ways of the column. The work table is bolted on the saddle and saddle is also mounted on the cross-rail. The work table along with the saddle can be moved horizontally by the table cross-feed screw.

### 19.5.3 Slotter Machine

Vertical shaper machine is also known as slotter machine in a workshop but the fundamental difference between vertical shaper and slotter machine is that the frame of the vertical shaper is fixed and cannot be tilted whereas the frame of slotter machine can be tilted at any angle. The small angle may be given to tool to the vertical shaper but if the larger deviation is required then slotter machine is used. The ram of slotter machine reciprocates in the vertical direction. It is used to cut the slot vertically. The construction detail and driving mechanism are very similar to shaper machine.

#### *Applications of Slotter Machine*

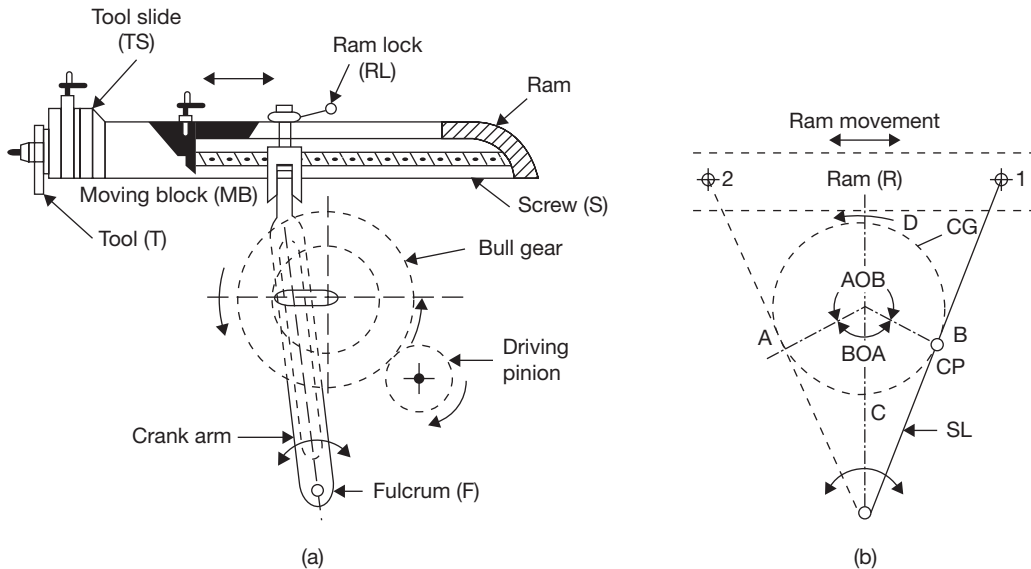
Slotter machine is applied:

- (a) To machine the vertical surface.
- (b) To machine the inclined surface.
- (c) To cut the internal and external gear teeth.
- (d) To machine the surfaces that are difficult to machine on the shaper.
- (e) To machine the blind hole.

### 19.5.4 Crank and Slotted Arm Quick Return Mechanism

Rotary motion of the bull gear is converted into a reciprocating motion of the ram through the crank and arm. The cutting is done in the forward stroke and the return stroke is idle. The time of return stroke is reduced to compress the total machining time which is known as quick return mechanism. The quick return mechanism may be attained by any of the methods—Whitworth quick return, crank and slotted arm, and hydraulic mechanism. In this text, crank and slotted arm mechanism is discussed as it is very simple in construction and operation.

The schematic diagram of the crank and slotted arm mechanism is shown in Figure 19.25 (a). The driving pinion, which receives power from electric motor directly or over head line shaft, drives the bull gear either directly or through back gears. The crank pin may be adjusted by



**FIGURE 19.25**

Crank and Slotted Arm Quick Return Mechanism

a hand wheel operating through suitable gears for specified length of the stroke. The slotted link is provided at its lower end, while the upper fork end is connected with the moving block. Crank pin is the connector between the crank gear and slotted link. The rotary motion of the crank gear transmits the rocking movements of the slotted link by the crank pin within the slot. This rocking movement of the slotted link is communicated to the reciprocating movement of the ram through the moving block which is locked with ram screw.

It is seen from the block diagram in Figure 19.25 (b) that the path traveled by the crank pin during the forward motion is much more than the backward motion. Since  $\angle BOA = 144^\circ$  and  $\angle AOB = 360^\circ - 144^\circ = 216^\circ$

$$\frac{\text{Cutting time}}{\text{Return time}} = \frac{\text{Cutting angle}}{\text{Return angle}} = \frac{\angle AOB}{\angle BOA} = \frac{216}{144} = 3 : 2$$

### 19.5.5 Specification of Shaper

The shaper can be specified in the following terms:

- Length of stroke (300 mm).
- Maximum horizontal travel of table (350 mm).
- Maximum vertical travel of table (365 mm).
- Maximum distance from table to ram.
- Maximum vertical travel of tool slide (117 mm).
- Length and width of table (300 × 250 mm).

### 19.5.6 Constructional Detail of Planer

A constructional detail of the planer is shown in Figure 19.26. There are following components of the planer:

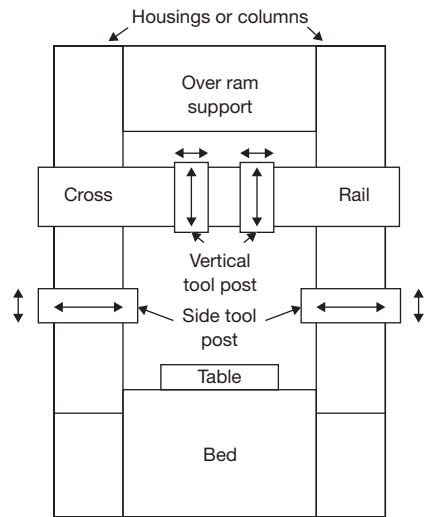
**Bed:** Bed is a cast iron structure; it is very large and heavy and supports whole structure of the machine over it.

**Table:** Table is made of cast iron. At its top, it carries longitudinal T-slots and holes to accommodate the clamping bolts and other devices. Under the table, chip pockets are provided integrated with it for collecting and removing the chips. On its side, the table carries adjustable stops to reverse its motion at the end of each stroke. At its both ends, it carries a trough to collect the chips.

**Housing or Columns:** The vertical members situated on both side or a single side of the planer is housing or column. Inside them, they carry the different mechanism for power transmission to the upper part of the machine, from the main drive. At their front, they are very accurately machined to form vertical ways along which the cross-rail slides up and down where side tool-heads are used; they also slide vertically along the same guide ways.

**Cross-rail:** It connects two housings and provides additional rigidity to the machine. It can slide up and down on the guideways provides on the column; there is the provision of guideways on the front side of the Crossrail to move the two tool head horizontally from one end to another end of the table.

**Tool Heads:** Maximum four tool heads can be fitted in a planer, two in the vertical position on cross rail and two in the horizontal position on columns. All of them can be used at the same time.

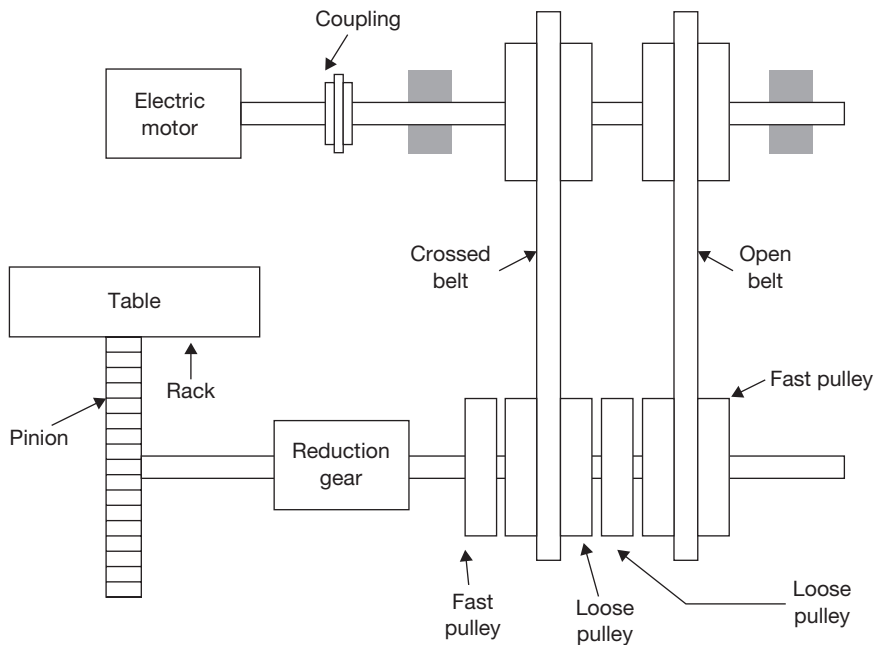


**FIGURE 19.26**

Constructional Details of the Planer

### 19.5.7 Fast and Loose Pulleys Driving Mechanism of Planer

A driving mechanism of a planer consists of an electric motor situated over the housing. The motor shaft is coupled with a counter shaft. The counter shaft, at its extreme end, carries two driving pulleys; one for the open belt and other for cross the belt. The main driving shaft is provided below the bed. Its one end passes through the housing and carries a pinion, which meshes with the rack provided under the table of the machine. The other end of the shaft carries two pairs of pulleys; each pair consists of a fast pulley and a loose pulley. One of these pairs is connected to one of the driving pulleys by means



**FIGURE 19.27**

Driving Mechanism of the Planer

of an open belt and the other to the second driving pulley by means of crossed belt. A speed reduction gear box is mounted on the main driving shaft and same is incorporated between the pinion and the pairs of driven pulleys. The driving mechanism is shown in Figure 19.27.

One set of the above pulleys is used for the forward motion and another set for the backward motion of the table. The cross belt is used for the forward motion and open belt is used for the backward motion. The driving pulley on the counter shaft for the cross belt is smaller than the pair of the fast and loose pulleys for the same. While the driving pulley on the driving shaft for open belt is bigger than the pair of fast and loose pulley on the same. This arrangement is provided for slow forward stroke and fast backward stroke.

The pulleys are so arranged that when the cross belt is on fast pulley, i.e., in the forward stroke, the open belt will be on the loose pulley and its reverse will take place during the return stroke. The relative shifting of the belt may take place automatically at the end of each stroke, without stopping the machine; a belt shifter and its operating lever are provided on the machine. Trip dogs are mounted at both ends of the table. At the end of each stroke, these dogs strike against the operating lever alternately and the belt shifted accordingly. Thus, table movement is reversed automatically.

### 19.5.8 Specifications of Planer

Planer can be specified in the following ways:

- (a) Horizontal distance between two housings.
- (b) Vertical distance between table top and cross-rail.
- (c) The maximum length of the stroke.

### 19.5.9 Difference between Shaper and Planer

**Table 19.2: Difference between Shaper and Planer**

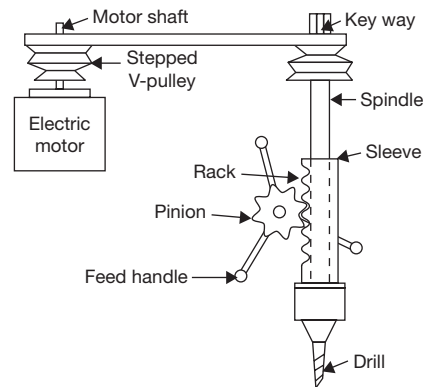
Shaper	Planer
1. Cutting takes place by reciprocating tool over the job.	1. Cutting takes place by reciprocating the job under the tool.
2. Feed is given to the job during the idle stroke of the ram.	2. Feed is given to the tool during the idle stroke of the work table.
3. The tools used on shaper are smaller and lighter.	3. The tools used on planer are larger, heavier and stronger than those used on the shaper.
4. This is suitable for smaller jobs.	4. This is used for larger and heavier job.
5. It is comparatively lighter and cheaper machine.	5. It is heavier, more rigid and costlier machine.

## 19.6 ► DRILLING MACHINE

Drilling machine is one of the important machine tools in a machine shop. It is mostly used to produce a hole in the solid material. In a drilling, the hole is generated by cutting edges of rotating cutting tool known as drill bit which exerts large force on the workpiece fixed on the table. Drilling, boring, counter-boring, counter sinking, reaming, tapping and spot facing operations can be performed on this machine.

### 19.6.1 Driving Mechanism in Drilling Machine

The power from the electric motor is transmitted to drill spindle pulley through V-belt. There is a provision of the key way on drill spindle to slide the stepped V-pulley. When the drill is required to feed into the work, it is pressed against the work by means of feed handle. As the handle is rotated, pinion rotates and rack moves longitudinally and hence the spindle and drill on the machine; drill rotates at very high speed to attain the required cutting speed. The complete driving mechanism is shown in Figure 19.28.



**FIGURE 19.28**

Driving Mechanism of a Drilling Machine



### 19.6.2 Drill Bit

The different part of the drill bit is shown in Figure 19.29.

**Flute:** the helical groove in the drill body is known as a flute. Its functions are to carry the chips, admit the coolant, make the chips to curl, and provide the cutting edges on the point.

**Point:** It is conical part of the drill; cutting lips are ground on the point.

**Body:** The part of the drill that is fluted and relieved is known as the body.

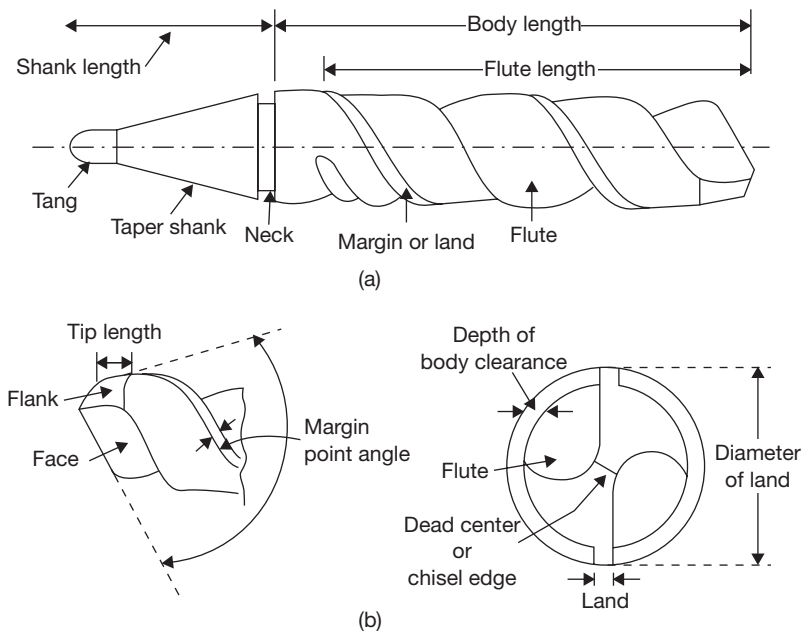
**Tang:** The flattened end of the taper shank is known as tang. It helps to remove the drill from socket or sleeve from the spindle without injuring the shank.

**Dead Center:** The point at which the two lips are properly ground and meet is known as dead center.

**Lips:** The cutting edges of a drill are known as lips. Both lips should have equal length, same angle of inclination and correct clearance.

**Margin or Land:** The narrow surface along the groove that determines the size of the drill and keeps the drill aligned is known as margin or land.

**Web:** The backbone of the drill of the narrow section between the flutes is known as the web.



**FIGURE 19.29**

Drill Nomenclature

**Heel:** The edge which is formed by the intersection of the flute surface and the body clearance is known as the heel.

### *Some Important Angles on a Drill*

**Rake Angle:** It is also known as helix angle. The angle between a plane passing through drill axis and leading edge of the land is known as rake or helix angle. It varies from  $0^\circ$  to  $48^\circ$ . Higher values are suitable for softer materials and lower values are suitable for harder materials.

**Point Angle:** It is also known as cutting edge angle. It is the angle included between the two opposite lips of a drill, measured in a plane containing the axis of the drill and both the lips. The most common value of the angle is  $118^\circ$ . Smaller point angle is suitable for brittle material and a larger one for harder and tougher materials.

**Chisel Edge Angle:** The obtuse angle formed between the lip and the chisel edge is known as chisel edge angle. The greater the angle larger will be clearance. It ranges from  $120^\circ$  to  $135^\circ$ .

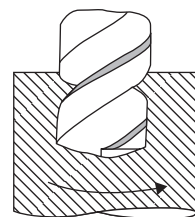
### 19.6.3 Specifications of a Drilling Machine

Drilling machines are specified in the following ways:

- The maximum size of the drill in mm.
- Table size.
- The maximum spindle travel.
- Range of spindle speed in rpm.
- Power input of the machine in H.P.

### 19.6.4 Operations Performed on Drilling Machine

**Drilling:** The operation of producing a circular hole by removing metal by rotation the cutting edges of a drill is known as drilling. Metal is removed by shearing and extrusion (Figure 19.30). Drilled hole is slightly oversized due to non-alignment of the tool and vibration of the spindle. For producing an accurate hole, the drill bit selected is slightly smaller than the hole-diameter required. After producing the hole reaming is required for finishing.



**FIGURE 19.30**

Drilling

**Reaming:** It is an operation to produce a finished hole after drilling. Since the material removal rate in reaming is very less (0.4 mm) therefore it is rarely used for enlarging the hole. Reamer has straight teeth which is given a rotational motion similar to drilling. The reaming operation is shown in Figure 19.31.

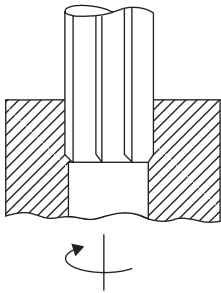


FIGURE 19.31

Reaming

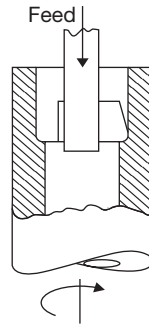


FIGURE 19.32

Boring

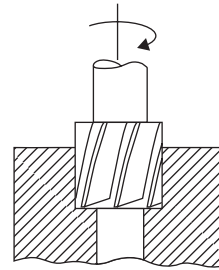


FIGURE 19.33

Counter boring

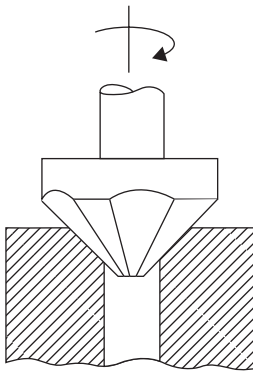


FIGURE 19.34

Counter Sinking

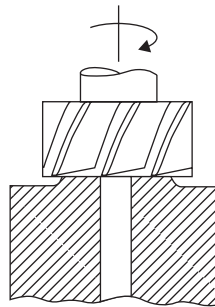


FIGURE 19.35

Spot Facing

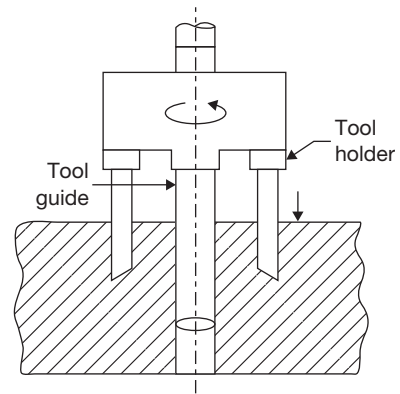


FIGURE 19.36

Trepanning

**Boring:** It is an operation to enlarge the drilled hole. It has single cutting point cutter as shown in Figure 19.32. In Boring, the material removal rate is larger than that of drilling. Therefore for enlarging purpose boring tool is used in place of large diameter drill bit.

**Counter Boring:** The operation of enlarging the end of a hole cylindrically, as a recess for a bolt head, is known as counter boring. The counter boring process is shown in Figure 19.33.

**Counter Sinking:** The operation of making a cone shape enlargement of the end of a hole, as for the accommodating the screw head, is known as counter sinking (Figure 19.34).

**Spot Facing:** The operation of squaring and smoothing the surface around a hole, as for the seat for a nut or head of a bolt, etc., is known as spot facing (Figure 19.35).

**Trepanning:** The operation of producing a large hole (diameter over 50 mm) by removing metal along the circumference of a hollow cutting tool, which enters the small previously drilled hole to produce the larger hole concentric is known as trepanning (Figure 19.36).

It is used for the diameter more than the capacity of the particular machine and where hole depth is much more in comparison with normal work.

### 19.6.5 Advanced Types of Drilling Machine

#### *Radial Drilling Machine*

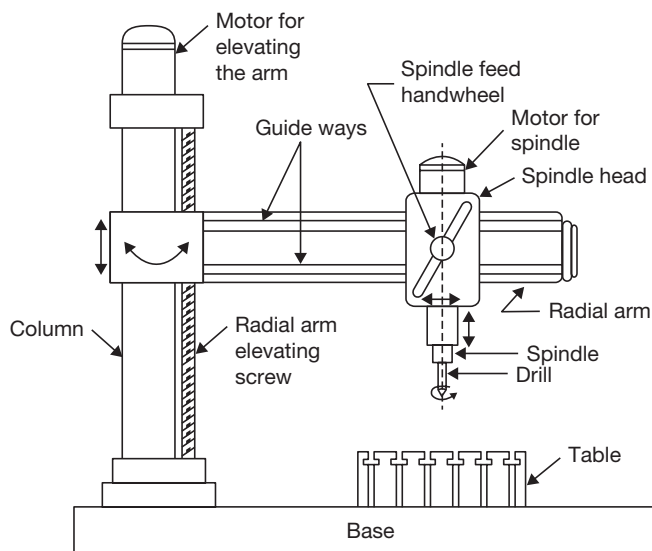
Radial drilling machine is a heavy duty machine. It consists of a vertical column supporting a horizontal arm on which drill spindle can move in a radial direction. The arm can be raised or lowered and swung around any position over the work. Two electric motors are used as shown in Figure 19.37, one used to provide movement to the arm and other is used to drive spindle of the drilling machine.

#### *Gang Drilling Machine*

Gang drilling machine is used for mass production where a number of drilling operations are to be performed in sequence. Each drill head can be equipped with different types of drill bits. There may be 2 to 10 spindles. The construction of gang drilling machine is shown in Figure 19.38.

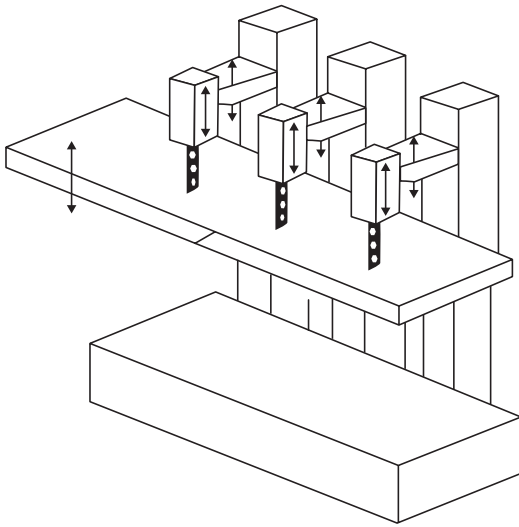
#### *Multi-spindle Drilling Machine*

A multi-spindle drilling machine has a number of spindles driven by a single motor. All the spindles holding the drills can be used simultaneously. It can produce a number of parallel

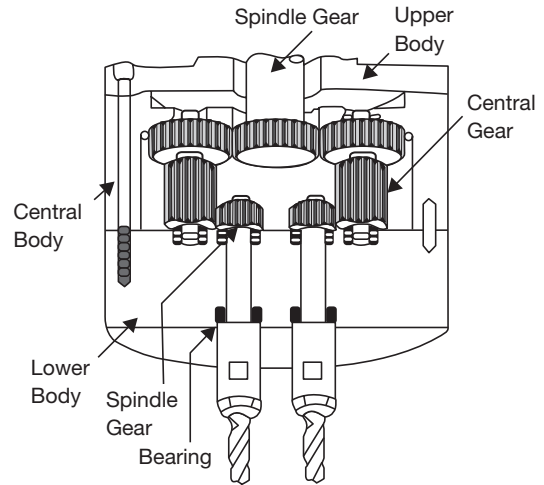


**FIGURE 19.37**

Radial Drilling Machine

**FIGURE 19.38**

Gang Drilling Machine

**FIGURE 19.39**

Multi-spindle Drilling Machine

holes simultaneously. It is employed for a light work. The construction of multi-spindle drilling machine is shown in Figure 19.39.

## 19.7 ► BORING

Boring machine is one of the versatile machine tools. This is most suitable for machining of a large and heavy workpiece in mass production, for example, a cylinder of I.C. engines, machine housing, engine frame, etc. This machine can perform all the operations which can be done on the drilling machine. But this machine is heavier than the drilling machine.

### 19.7.1 Specification of Boring Machines

Main specification of a boring machine is designated by the following terms:

- Type of machines.
- Maximum size of boring spindle diameter (50–320 mm).
- Maximum spindle travel in horizontal and vertical direction.
- Maximum travel of the table in longitudinal and crosswise directions in mm.
- Range of spindle speeds in rpm.
- Power of the motor in H.P.

## 19.8 ► MILLING MACHINES

Milling is a metal cutting process in which different shapes and sizes of the surface are generated by cutting action of rotating multipoint cutter fixed on a periphery of a wheel and feed is given to the work. The shaft on which milling cutter is mounted is known as arbor, this may be horizontal or vertical. On the basis of the position of the arbor, a milling machine can be divided into two classes—horizontal and vertical milling machines as shown in Figure 19.40. The size of the milling machine is generally denoted by the dimension of the table. Different manufacturers denote these sizes by different numbers such as 0, 1, 2, 3, 4, 5, 6, etc. Each of these numbers indicates a particular standard size adopted by the manufacturer.

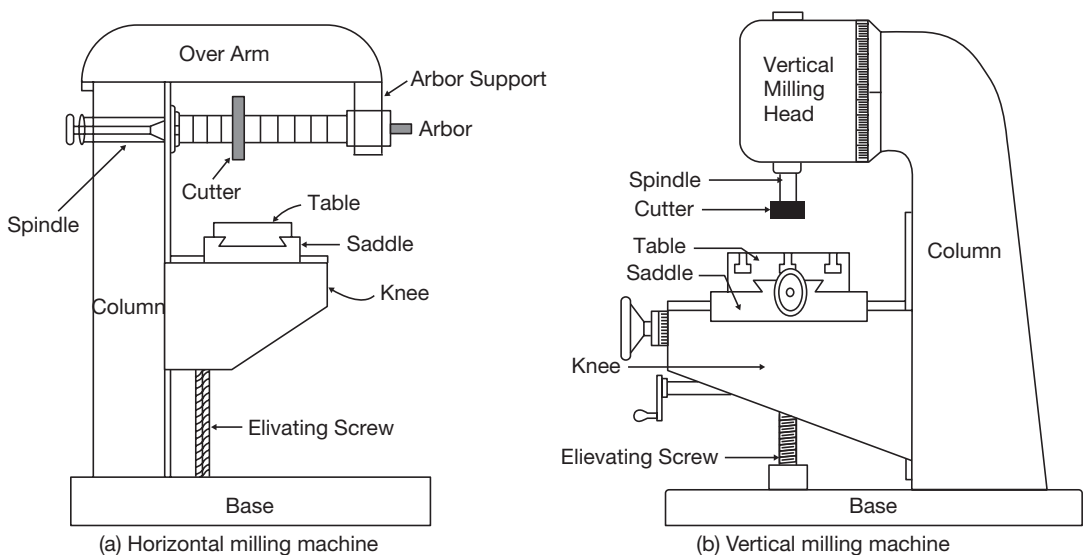
The various types of milling machines are column and knee type, fixed bed type, planer type, production milling machine, and special purpose milling machine.

### 19.8.1 Constructional Detail of Milling Machine

**Base:** The base is foundation part of a milling machine. It is made of gray cast iron. It absorbs vibrations and supports column, table arbor, etc.

**Column:** It is the main casting mounted on one side of the base. This is box shaped and fitted with gearing arrangement for different spindle speeds and table feeds (Figure 19.40).

**Knee:** It is rigid gray cast iron part that supports and provides adjustment for the height of the table, operating by the table elevating screw and slides up and down on the vertical



**FIGURE 19.40**

Horizontal and Vertical Milling Machines

dovetail guide ways of the column. It carries the table feed mechanism and controls to feed in longitudinal, cross, vertical and rotational, etc., either by hand power or machine power.

**Table:** Table is the part on which job is mounted either directly by a clamp or by a fixture. It rests on the saddle and travels longitudinally. The table travel is limited by the adjustable stops in either direction during power feeding. In the case of universal milling machine, there is an arrangement of the table to swivel horizontally around the center of its base.

**Feed Gear Box:** The variation of power feed to all movement is achieved through the feed gear box. The power from the feed gear box is transferred to the knee by a telescopic shaft. The number and amount of feed depending on the gearing arrangements in the feed gear box.

**Spindle:** The spindle is mounted on the upper part of the column. It receives power from the motor through belts, gears, clutches, etc., and can be rotated at different speeds by the step-cone-pulley drive or gear drive.

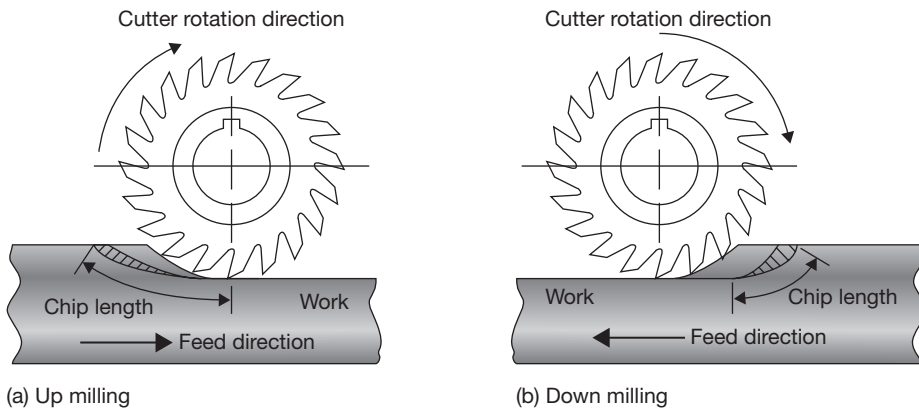
**Arbor:** The arbor is an extension of the spindle on which various cutters are mounted. The arbor is set in spindle cone (Morse taper cone) and tightened by draw bolt held in position by a bush nut.

### 19.8.2 Basic Milling Operations

**Up Milling and Down Milling:** The horizontal milling is divided into two groups—up milling and down milling. If the direction of cutting and feed are opposite to each other, the milling is known as up milling, and if the directions of both are the same, the milling is known as down milling as shown in Figure 19.41. In down milling, there is a tendency of the job being dragged into the cutter, therefore, up milling is safer and is commonly used. However, down milling results in better surface finish and longer tool life. In down milling, the chip thickness starts at maximum and decreases to its minimum value at the end of the cut where tooth leaves the work. In up milling, the chip thickness starts at zero and increases to its maximum value at the end of the cut where the tooth leaves the work. Cutting forces tend to lift the workpiece up from the table, hence the name up milling.

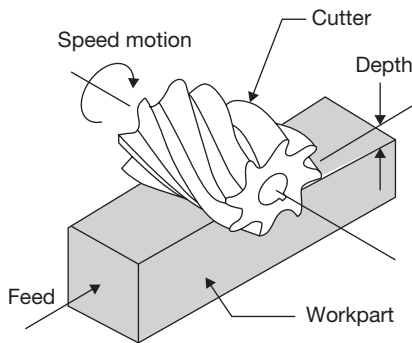
**Slab Milling:** Slab milling, also called peripheral milling or plane milling generates flat surfaces by using the teeth located on the periphery of the cutter body as shown in Figure 19.42. The axis of cutter rotation is parallel to the workpiece surface to be machined. The diameter and width of the cutter depend on a part is to be slab milled.

Generally, helical teeth cutter is selected for slab milling. Less force is required; vibration and chatter are reduced; and a better quality of surface finish is produced with a helical tooth cutter than with a straight tooth cutter. This is possible because of the fact that the helical teeth are continuously engaged in comparison with the intermittent cutting action of straight tooth cutter. Milling cutters up to 18 mm wide generally have straight teeth and cutters over 18 mm wide usually have helical teeth. The angle of helix ranges from 45° to 60° or steeper. Straight cutters are used for light duty and helical for heavy duty.



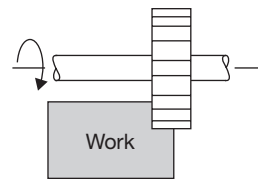
**FIGURE 19.41**

Up Milling and Down Milling



**FIGURE 19.42**

Slab Milling



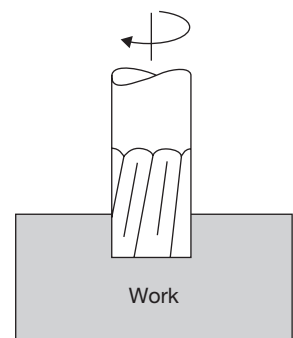
**FIGURE 19.43**

Side Milling

**Side Milling:** Side milling uses side milling cutters similar to plain milling cutters. However, in addition to teeth around the periphery, other cutters are formed on one or both sides as shown in Figure 19.43. The teeth may be either straight helical. Most of the cutting is done by the teeth around the periphery.

The side cutting teeth cut the side of the workpiece. Side mills are not recommended for milling slots because of their tendency to mill wider.

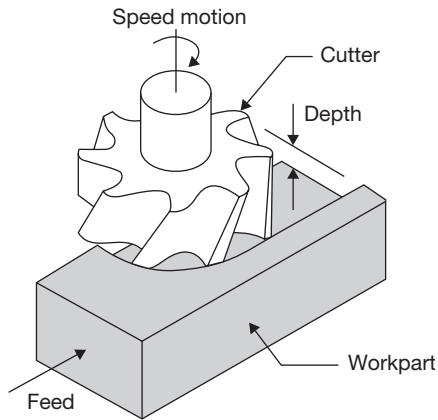
**End Milling:** End milling is a process of machining horizontal, vertical, angular and irregular shaped surfaces. The cutting tool is called an end mill as shown in Figure 19.44. End mills are coarse tooth cutters and made of high-speed steel or have



**FIGURE 19.44**

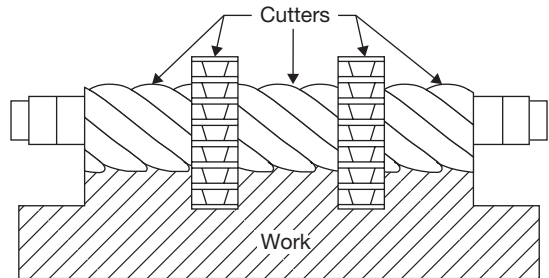
End Milling





**FIGURE 19.45**

Face Milling



**FIGURE 19.46**

Gang Milling

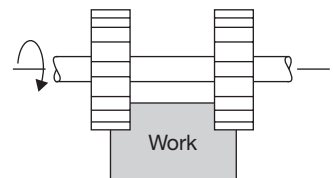
carbide inserts. They are subjected to severe torsion and bending stresses in use. These limit the size of cut that can be taken. With a cut equal to the full width of the cutter, the maximum recommended a depth of cut in  $0.6D$ ,  $D$  being the diameter of the end mill. If, however, the cutting action is the cleaning up of the edge of a component, with the cut only 10% of the diameter, the depth can be increased to  $1.5D$ . This process can be used to mill grooves, slots, keyways, and large surfaces. It is also widely used for profile milling in die making.

**Face Milling:** Face milling is an extension of end milling where the cutter has large diameter with several cutting teeth as shown in Figure 19.45. The cutter diameter is usually 6 inches or more. The teeth are beveled or rounded at the periphery of the cutter.

Face milling cutters are made of high-speed steels, cast alloys or carbides and are heavy-duty cutters. Heavy cuts, coarse feeds, and high cutting speeds are essential. The cutter is mounted on a spindle having an axis of rotation perpendicular to the workpiece surface; Face milling is used to produce a flat surface and has a wide variety of applications.

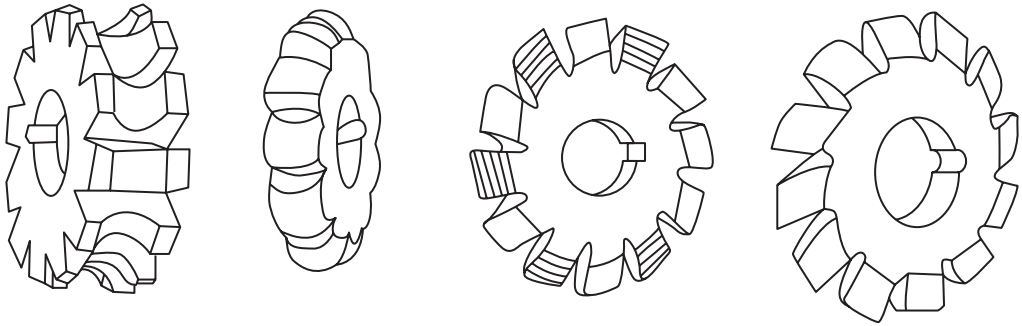
**Gang Milling:** It is the milling operation which involves the use of a combination of more than two cutters, mounted on a common arbor, for milling a number of flat horizontal and vertical surfaces of a workpiece simultaneously as shown in Figure 19.46. This combination may consist of only side milling cutters or plain milling cutters or both.

**Straddle Milling:** It is a milling operation in which a pair of side milling cutters is used for machining two parallel vertical surfaces of a workpiece simultaneously as shown in Figure 19.47.



**FIGURE 19.47**

Straddle Milling Cutter



**FIGURE 19.48**

Form Milling Cutters

**Form Milling:** This milling process is employed for machining those surfaces which are of irregular shapes. The cutter used, called a form milling cutter, will have the shape of its cutting conforming to the profile of the surface to be produced. Form milling cutter is shown in Figure 19.48.

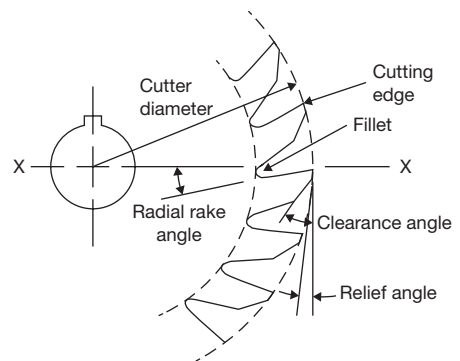
**Profile Milling:** It is the operation in which the profile of a template or the shape of the cavity of a master-die is duplicated on the work surface. The movement of the cutter is guided by a tracer control unit which carries a contact finger. This finger (stylus) run in contact with the outline to be duplicated and the tracer mechanism guides the tool movement accordingly.

### 19.8.3 Nomenclature of Milling Cutter

**Radial Rake Angle:** It is the angle between the flute face and a radial reference plane XX drawn from the cutter axis to the cutting edge. Positive radial rake angle is used for high-speed cutters and to cut the soft materials like aluminum. Negative rake angle is used for high-speed milling with carbide tipped cutter and to cut the hard materials.

**Relief Angle:** It is the angle between the land and a tangent to the cutter from the tip of the tooth. It eliminates the tendency of the teeth to rub the work. The angle may vary from 3 to 5 degrees, with higher angles  $8^\circ$  to  $10^\circ$  for smaller diameter and soft work materials.

**Clearance Angle:** It is the angle between the back of the tooth and a tangent to the cutter from the tip of the tooth (Figure 19.49).



**FIGURE 19.49**

Nomenclature of Milling Cutter

## 19.9 ► GRINDING MACHINES

Grind means to wear or to abrade by friction. The grinding process may be defined as the removal of a layer of a work piece by rotating an abrasive wheel. It is very similar to milling process as each abrasive particle at the periphery of the grinding wheel acts like a tooth of the milling cutter, but the orientation of the abrasive particles are random in the grinding wheel. The chips formed in this process are very small and the geometry of the chips can be seen with the help of a microscope.

### 19.9.1 Grinding Wheel Specification

The application of the different types of grinding wheels depends on the properties of the work materials and the type of applications. In the alphanumeric system, a grinding wheel can be specified by 7-terms as shown in Figure 19.50.

**Code Number:** It is optional and used by manufacturers to indicate exact type of abrasive.

**Abrasive Types:** An abrasive is a hard material, which can be used to cut or wear away other materials. The major types of abrasives used in the grinding wheel are natural abrasives and artificial abrasives. Natural abrasives include a sand tone or solid quartz, Emery (50–60% crystalline  $\text{Al}_2\text{O}_3$  plus iron oxide), Corundum (75–90% crystalline  $\text{Al}_2\text{O}_3$  plus iron oxide), diamond, and garnet whereas artificial abrasive include A:  $\text{Al}_2\text{O}_3$ ; C: SiC; D: Diamond. Other abrasives are boron carbide and cubic boron nitride may be used as artificial abrasives.

**Grit Size:** Grit size is used to indicate the grain size that is reciprocal of grit size in inch. For example, if grit size is 36 then the grain size will be equal to 1/36 inch. Using the larger grains, material removal capacity will be the more, but the quality of the surface finish will be poor. The grain size is determined primarily by the surface quality requirements. Grit size is defined in terms of a number as given below:

Coarse: 10–24; Medium: 30–60; Fine: 70–180; Very fine: 220–600.

**Grade:** The grade indicates the strength of the bonding material. A hard wheel means strong of the bonding and the abrasive grains can withstand large forces without getting dislodged from the wheel and in the case of a soft wheel, the situation is just reverse. If the work

Code	Abrasive	Grit	Grade	Structure	Bond	Manufacture's Record
48	A	36	M	7	V	24

**FIGURE 19.50**

Grinding Wheel Specification

material is hard and wheel used is also hard, the grains wear out easily and the sharpness of the cutting edges quickly lost. This is known as *glazing* of the wheel. A glazed wheel cuts less and rubs more making the process inefficient. To avoid this problem, a soft wheel is used for harder materials so that the grains, which lose the sharpness, get easily dislodged as the machining force on the individual grain increases. The layers of new grains are exposed, maintaining the sharpness of the wheel.

If the work material is soft, a hard wheel should be employed since the problem of glazing will be absent and a longer wheel life will be achieved. The grade of the grinding wheel is indicated in terms of capital alphabetic letters as:

Soft: A-H; Medium: J-P; Hard: Q-Z.

**Structure:** The grinding wheel is similar to a milling cutter with a very large number of randomly oriented teeth. Therefore, it must have voids to allow spaces for the chips. If the voids are too small for the chips, the chips stay in the wheel blocking the voids. This is known as wheel loading, which causes inefficient cutting. If the voids are too large, again the cutting action is inefficient since there will be less cutting edges. In an open structure, the grains are not too densely packed and in a wheel, with a closed structure, the grains are tightly packed. For grinding of ductile work materials, larger chips are produced and to reduce the tendency of wheel loading, an open structure is preferred. In the case of hard and brittle work materials, a closed structure is selected. The structure depends on the required grade and also, on the nature of cut. For a rough cut, an open structure is more suitable. The structure is represented by some numbers as:

Dense: Less than 10; Open: 11–16.

**Bond:** It represents the binding materials use of to bind the abrasive particles. Some alphabetic letter is used to indicate the Bond as—Vitrified-V; Resinoid-B; Silicate-S; Rubber-R; Shellac-E.

**Vitrified Bond:** It is a clay bond, reddish brown in color. The base material is feldspar, which is fusible clay. The exact proportion of the refractories and flux are added to it and mixed thoroughly. The mixture, together with the abrasive grains, is fed into revolving drums containing water, where all the constituents make together to form a pest. The pest is then placed in a mold to get the shape of a wheel and air dried at room temperature. Thus, the wheel becomes enough hard. Now, the wheel is fed into a kiln and allowed to remain for a few days. The inside temperature is being about 1260°C, the process is known as fusing and it provides the uniform distribution of bond throughout the wheel. It is used for the speed of 32 m/sec.

**Silicate Bond:** In this bond, silicate of soda is mixed with the abrasive grains and the mixture is packed and rammed in a metal molds. After drying for several hours, the wheels are baked at 260°C for 1–3 days. Silicate wheels are milder than those made by other processes and wear away more rapidly. They are suitable for grinding the edges of cutting tools where the heat must

be kept to a minimum. This process is also recommended for very large wheels since they have little tendency to crack or warp in the baking process. The hardness of the wheel is controlled by the amount of silicate of soda.

**Shellac Bond:** The abrasive grains are first coated with shellac by mixing in a steam heated mixer. The material is then placed in heated steel molds and rolled or pressed. Finally, the wheels are baked for a few hours at a temperature around 300°F. This bond is adapted to thin wheels, as it is very strong and has some elasticity. Shellac bonded wheels are also used for grinding cam shafts and other parts where a high polished is desired. Other uses are sharpening large saws, cutting of operation, and finishing large rolls. They can run safely in the water, but use of the oil or caustic soda should be avoided.

**Rubber Bond:** Pure rubber with sulfur as a vulcanizing agent is mixed with the abrasive by running the material between heated mixing rolls. It is rolled to a fixed thickness and the wheel are cut out with a proper shaped die and then vulcanized under pressure. A very thin wheel can be made by this process because of the elasticity of the material. Wheels having this bond are used for high speed grinding as 45–80 m/sec. They are used a great deal as snagging wheels in foundries and also cutting off wheel.

**Bakelite or Resinoid Bond:** In this process, the abrasive grains are mixed with a synthetic resin powder and a liquid solvent. This plastic mixture is then molded to proper shape and baked in an electric oven at 200°C for one-half to three days. This bond is very hard and strong, and wheels made by this process can be operated at speed around 50–80 m/sec. They are used for general purpose grinding and are widely used in foundries and billet shops for snagging purposes because of their ability to remove metal rapidly.

**Oxychloride Bond:** It is a mixture of oxide and chloride of magnesium and setting takes place in the cold state. The process of wheel manufacture is similar to the above two but no heating and subsequent cooling is required on account of the cold setting property. Aging is, however, necessary so that the bonded wheel gets adequate hardness. The bond provides a cool cutting action. But, grinding is usually done dry as it is very susceptible to the action of conventional coolants and, therefore, the full use of the cutting capability of the wheel cannot be taken.

**Manufacturer's Record:** Optional for manufacturer's code number.

### 19.9.2 Methods of Grindings

A number of grinding methods are used according to shape and size of the jobs. Some of the commonly used methods can be given below as:

**Cylindrical Grinding:** It means grinding of outside cylindrical and tapered surface.

**Internal Grinding:** It means a method of grinding the internal surfaces of cylindrical or tapered holes.

**Surface Grinding:** It is a method of grinding the internal surfaces of cylindrical or tapered holes.

**Face Grinding:** It is a method of grinding vertical flat surfaces. The wheel spindle can be horizontal or vertical.

**Infeed or Plunge Cut Grinding:** It is also a method of grinding very short work pieces. It involves the use of grinding wheel having its face wider than the length of the surface to be ground and feeding the same into the work with no traversing motion of it.

**Form Grinding:** It is a method of producing formed surface through grinding. The wheel face is given the desired shape by dressing and then fed on the work surface, as in the case of thread grinding and the gear teeth grinding.

**Centerless Grinding:** It is a method of grinding external cylindrical surfaces, in which work is supported by a regulating wheel, a grinding wheel, and a work rest blade.

**Off Hand Grinding:** It is a rough grinding method in which the work is held in hand and pressed against the rotating grinding wheel. This method is commonly used for grindings of such items in which accuracy and surface finish are not of primary importance, such as in sharpening cutting edges of chisels, etc.

**Sharpening Cutting Tools:** Several cutting tools, including single point tools, milling cutters, drills, reamers, hobs, correct geometry, restore lost geometry, and sharpen their cutting edges.

**Creep Feed grinding:** It is a method in which a soft grinding wheel is used. The wheel revolves in position while the work is fed past the revolving wheel at a very slow speed. Multi passes are avoided and the entire depth of material is removed in a single pass. Ample amount of coolant usually sulfurized oil, under pressure, is used in the process. The dressing of the grinding wheel is continuously done during the process, for which a diamond coated dressing wheel (roll) is mounted above the grinding wheel.

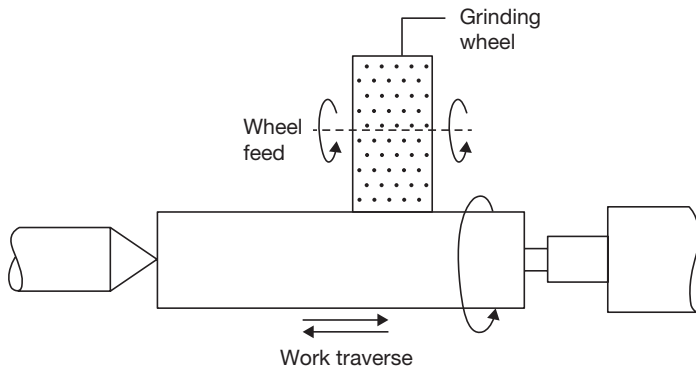
### *Types of Grinding Machines*

**Broadly, the Grinding Machine can be Classified as:** Rough grinders and Precision grinders. The main aim with rough grinders is to remove more materials than the quality of surface finish. Therefore, it is also known as non-precision grinders. These grinders include—Bench, pedestal or floor grinders, Swing frame grinders, Portable and flexible shaft grinders, and Belt grinders.

**Precision Grinders:** There are a large number of precision grinders, but in this text, we will discuss only cylindrical type grinders only for the basic information.

### **19.9.3 Cylindrical Grinders**

The principle of operation of cylindrical grinding is shown in Figure 19.51. It consists of holding fixtures rotating about its axis and feeding a fast revolving grinding wheel against

**FIGURE 19.51**

Cylindrical Grinders

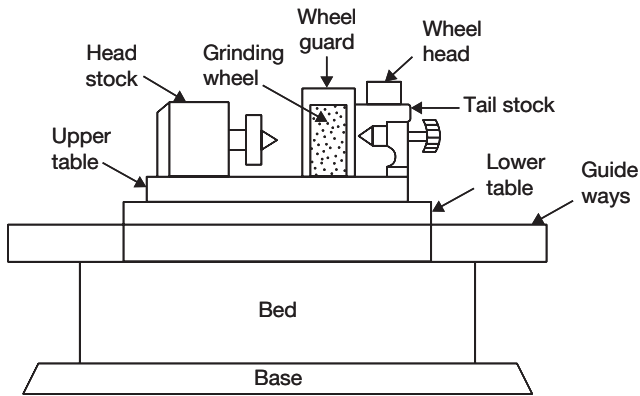
the same. If the work surface to be ground is longer than the face width of the grinding wheel, the work is traversed past the wheel or wheel past the work. In the case of the larger face width of the wheel than the work length, the wheel may be fed in with no traversing movement of it or that the work. This is known as plunge grinding. There are three types of cylindrical grinders—plain cylindrical grinders, plain surface grinders, universal cylindrical grinders, and centerless grinders.

### 19.9.4 Plain Cylindrical Grinders

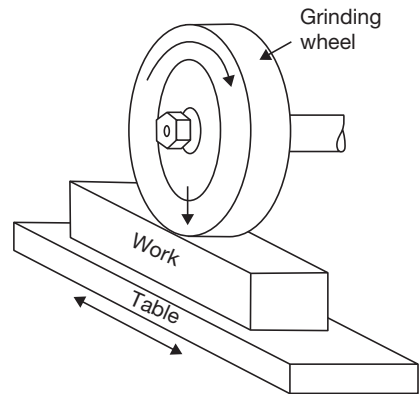
In these grinders, the workpiece is held between two centers, i.e., headstock and tailstock. The rotating wheel is traversed across the face of the rotating grinding wheel as shown in Figure 19.52. At the end of each traverse, wheel is fed into the work by an amount equal to the depth of cut. Tailstock and headstock both can be moved along the table to suit the work. The table is usually made of two parts—the upper table carries the tailstock, headstock, and the workpiece and can be swiveled in a horizontal plane to a maximum of  $10^\circ$  on either side, along with the circular ways provided on the lower table. This enables grinding of tapered surfaces. The lower table is mounted over horizontal guide ways to provide longitudinal traversed to the upper table, and hence the work. Table movement can be both by hand as well as power.

### 19.9.5 Plain Surface Grinders

A plane surface grinder produces a flat surface by reciprocating the job and rotating the abrasive wheel as shown in Figure 19.53. It is similar to a planer. It consists of a movable table, which can move in longitudinal as well as in transverse direction. The table is equipped

**FIGURE 19.52**

Plain Cylindrical Grinders

**FIGURE 19.53**

Plane Surface Grinders

with the magnetic chuck to hold the job. The grinding wheel is mounted on a horizontal or vertical spindle depends on the needs. The grinding wheel and the spindle are mounted on a column, which allows it to be raised or lowered. The feed motion is given to the job as in shaper and planer. The rotating motion is given to the abrasive wheel.

### 19.9.6 Universal Cylindrical Grinders

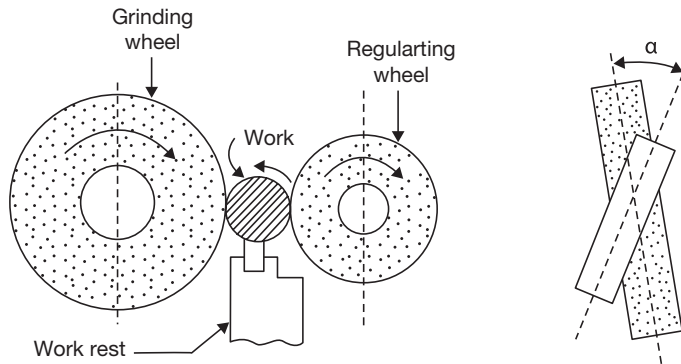
There are following extra facilities in the universal cylindrical grinder than the plain cylindrical grinder:

1. Its headstock can be made to carry alive or dead spindle, as desired, the former being needed when the work is held in a chuck.
2. The headstock can itself be swiveled in a horizontal plane.
3. Its wheel head can be raised or lowered and can also be swiveled to either side by  $90^\circ$  to grind taper surfaces having large taper angles.

### 19.9.7 Centerless Grinders

These grinders are also a type of cylindrical grinders but the principle of centerless grinding differs from center type grinding in that the work, instead of being mounted between centers, is supported by a combination of a grinding wheel, a regulating wheel, and a work-rest blade as shown in Figure 19.54. The principle of centerless grinding is used for both the external grinding as well as internal grinding. Many hollow cylindrical and tapered workpieces, like bushes, pistons, valves, tube, and balls, etc, which are the best ground on centerless grinders.



**FIGURE 19.54**

Centerless Grinding

### Advantages of Grinding

- ▶ It is the only method of cutting such materials as hardened steel parts requiring hard surfaces are first machined to shape while the metal is in an annealed state and then only a small amount of excess material is removed by the grinding operations.
- ▶ It produces good finishing that is extremely smooth and, hence, very desirable at contact and bearing surfaces. As the wheel has a considerable width, there are no marks as result of feeding it across the work.
- ▶ Grinding can finish work to very accurate dimensions in a short time. Since only a small amount of material is removed, the grinding machines require a close regulation of the wheel, and it is possible to hold work to a fraction of a thousandth of an inch with the considerable case.
- ▶ Very little pressure is required in this process, thus permitting its use in very light work that would otherwise tend to spring away from the tool. This characteristic permits the use of magnetic chucks for holding the work in many grinding operations.
- ▶ Abrasives have very high hardness, are less sensitive to heat compared to other materials and can sustain high-temperature.

## RECAP ZONE .....



### Points to Remember

- The removal of extra material from a metal surface by shearing or cutting action is known as machining or **metal cutting**.
- In metal cutting the line generated by the cutting motion is called **generatrix** and the line formed by feed motion is called **directrix**.

- **Back rake angle** is the angle between the face of the tool and a line parallel with the base of the tool measured in a perpendicular plane to the side cutting edge.
- **Side rake angle** is the angle between the base of the tool shank and the face of the tool measured in a plane perpendicular to the plane through the **side cutting edge** and at the right angle to the base.
- The angle between the planes of the end flank immediately below the end cutting edge and a line perpendicular to the base and right angle to the axis is known as **end relief angle**.
- The angle between the planes of the side flank immediately below the side cutting edge and a line perpendicular to the base along the axis is known as **side relief angle**.
- The angle between the plane of the end cutting edge and the plane perpendicular to the axis, both right angles to the base, is known as an **end cutting edge angle**.
- The angle between the plane of the side cutting edge and the plane perpendicular to the axis, both right angles to the base, is known as a **side cutting edge angle**.
- The **nose radius** has a major influence on surface finish. A sharp point at the end of a tool leaves a groove on the path of cut.
- **Orthogonal cutting** is a machining process in which the cutting edge of the tool is kept perpendicular to the direction of the tool travel.
- In **oblique cutting**, the cutting edge of the tool is inclined at some acute angle to the direction of the tool travel.
- On the lathe, a rotational motion is provided to the job and translational motion is provided to the cutting tool.
- **Turning** is a metal removal process in which job is given rotational motion while the cutting tool is given linear (feed and depth of cut) motion.
- The operation of producing a circular hole by removing metal by rotation the cutting edges of a drill is known as **drilling**.
- The operation of finishing and sizing a previously drilled hole using a multi-edges straight cutting tool named as reamer is known as **reaming**.
- The operation of enlarging and finishing a previously drilled hole throughout its length by means of an adjustable single edge cutting tool named as boring tool is known as **boring**.
- In a **shaper**, cutting takes place by reciprocating tool over the job.
- In a **planer**, cutting takes place by reciprocating the job under the tool.
- The operation of producing a large hole (diameter over 50 mm) by removing metal along the circumference of a hollow cutting tool, which enters the small previously drilled hole to produce the larger hole concentric is known as **trepanning**.
- **Radial drilling machine** consists of a vertical column supporting a horizontal arm on which drill spindle can move in a radial direction.
- **Gang drilling machine** is used for mass production where a number of drilling operations are to be performed in sequence. Each drill head can be equipped with different types of drill bits.
- A **multispindle drilling machine** has a number of spindles driven by a single motor. All the spindles holding the drills can be used simultaneously. It can produce a number of parallel holes simultaneously.
- **Milling** is a metal cutting process in which different shapes and sizes of the surface are generated by cutting action of rotating multipoint cutter fixed on a periphery of a wheel and feed is given to the work.
- If the direction of cutting and feed are opposite to each other, the milling is known as **up milling**, and if the directions of both are the same, the milling is known as **down milling**.
- **Slab milling**, also called peripheral milling or plane milling generates flat surfaces by using the teeth located on the periphery of the cutter body.

- **Side milling** uses side milling cutters similar to plain milling cutters. However, in addition to teeth around the periphery, other cutters are formed on one or both sides.
- **End milling** is a process of machining horizontal, vertical, angular and irregular shaped surfaces.
- **Face milling** is an extension of end milling where the cutter has large diameter with several cutting teeth.
- **Gang milling** is the milling operation which involves the use of a combination of more than two cutters, mounted on a common arbor, for milling a number of flat horizontal and vertical surfaces of a work-piece simultaneously.
- **Straddle milling** is a milling operation in which a pair of side milling cutters is used for machining two parallel vertical surfaces of a workpiece simultaneously.
- **Form milling** is employed for machining those surfaces, which are of irregular shapes. The cutter used, called a form milling cutter, will have the shape of its cutting conforming to the profile of the surface to be produced.
- **Profile milling** is the operation in which the profile of a template or the shape of the cavity of a master-die is duplicated on the work surface.



## REVIEW ZONE .....

### Multiple-choice Questions

1. The cutting edge of the tool is perpendicular to the direction of tool travel in:
  - (a) Orthogonal cutting of metal
  - (b) Oblique cutting of metal
  - (c) Both
  - (d) None of the above
2. The cutting edge of the tool is inclined at an angle less than  $90^\circ$  to the direction of tool travel in:
  - (a) Orthogonal cutting of metal
  - (b) Oblique cutting of metal
  - (c) Both
  - (d) None of the above
3. In metal cutting operations, discontinuous chips are produced while machining:
  - (a) Brittle materials
  - (b) Ductile materials
  - (c) Hard materials
  - (d) Soft materials
4. In metal cutting operations, continuous chips are produced while machining:
  - (a) Brittle materials
  - (b) Ductile materials
  - (c) Hard materials
  - (d) Soft materials
5. Size of shaper is specified by:
  - (a) The length of stroke
  - (b) The size of the table
  - (c) The maximum size of the tool
  - (d) H.P. of motor
6. Size of planer is specified by:
  - (a) The length of stroke
  - (b) The size of the table
  - (c) The maximum size of the tool
  - (d) H.P. of motor
7. A standard ground drill has a point angle of:
  - (a)  $90^\circ$
  - (b)  $100^\circ$
  - (c)  $118^\circ$
  - (d)  $120^\circ$
8. For harder materials, point angle of drill:
  - (a) Increases
  - (b) Decreases
  - (c) Kept at  $118^\circ$
  - (d) None of the above
9. One of the important parameters of lathe specification is:
  - (a) Swing over bed
  - (b) Swing over tool post
  - (c) The distance between centers
  - (d) Horse power
10. Centering can be done most accurately on:
  - (a) Four-jaw chuck
  - (b) Three-jaw chuck
  - (c) Lathe dog
  - (d) Collet
11. In gang milling:
  - (a) Several jobs can be performed in one set up
  - (b) One job is completed on several milling machines

- (c) Two or more cutters are mounted on the arbor then all remove the metals simultaneously  
 (d) None of the above
12. Spot facing is the operation of:  
 (a) Enlarging the end of a hole cylindrically  
 (b) Cone-shaped of the enlargement of the end of a hole  
 (c) Smoothing and squaring the surface around a hole  
 (d) Sizing and finishing a hole
13. counter sinking is the operation of:  
 (a) Enlarging the end of a hole cylindrically  
 (b) Cone-shaped of the enlargement of the end of a hole  
 (c) Smoothing and squaring the surface around a hole  
 (d) Sizing and finishing a hole
14. Reaming is an operation of:  
 (a) Enlarging the end of a hole cylindrically  
 (b) Cone-shaped of the enlargement of the end of a hole  
 (c) Smoothing and squaring the surface around a hole  
 (d) Sizing and finishing a hole
15. Drilling is a type of:  
 (a) Oblique cutting (b) Simple cutting  
 (c) Uniform cutting (d) Orthogonal cutting
16. Drill diameter is measured over the:  
 (a) Main body  
 (b) Margins at the drill point  
 (c) Heel  
 (d) Lips
17. The chip is cut off at thinnest place and then chip thickness increases along chip length in:  
 (a) Up milling (b) Down milling  
 (c) End milling (d) Climb milling
18. Maximum friction is caused in:  
 (a) Up milling (b) Down milling  
 (c) End milling (d) Climb milling
19. The cutting force tends to lift the work piece in:  
 (a) Conventional milling  
 (b) Down milling  
 (c) Climb milling  
 (d) Form milling
20. Advantages of conventional (up) milling is:  
 (a) Older machines have backlash in their lead screws can be used  
 (b) On sand casting cutter is not damaged  
 (c) Better finish obtained on steel but not on aluminum  
 (d) All the above
21. Disadvantage of conventional milling is:  
 (a) Chip gets picked up and carried around the cutter, thereby spoiling the finish  
 (b) On steel, the finish may be slightly rougher  
 (c) The machine must have zero backlashes or there will be chatter as the cutter tries to pull the table faster than the feed rate.  
 (d) All the above
22. Grinding is a process of removing materials by:  
 (a) Cutting action  
 (b) Rubbing action  
 (c) Wearing action  
 (d) Polishing action
23. After dressing operation, a grinding wheel is required to adjust the:  
 (a) Guard  
 (b) Eye shield  
 (c) Tool rest  
 (d) All of the above
24. In the case of cylindrical grinding, the depth of cut normally used for roughing is:  
 (a) 0.05 mm (b) 0.01 mm  
 (c) 0.005 mm (d) 0.001 mm
25. In the case of cylindrical grinding, the depth of cut normally used for roughing is:  
 (a) 0.05 mm (b) 0.01 mm  
 (c) 0.005 mm (d) 0.001 mm

## Fill in the Blanks

26. In metal cutting operation, chips are formed due to \_\_\_\_ of metal.
27. In center lathe, cutting tool is fed in \_\_\_\_ directions with reference to the lathe axis.
28. The work piece cannot be held in a lathe chuck can be clamped to a \_\_\_\_ mounted on a head-stock spindle.
29. The cutting action of a shaper occurs only on the \_\_\_\_ stroke of the ram.
30. Quick return motion is incorporated in a shaper, a planer and \_\_\_\_.
31. A slotter can be considered as a \_\_\_\_ shaper having only vertical movement of \_\_\_\_.
32. Any number of equal division can be obtained on milling machine by \_\_\_\_.

## Answers

1. (a)	2. (b)	3. (a)	4. (b)	5. (a)	6. (b)
7. (c)	8. (a)	9. (a)	10. (a)	11. (a)	12. (a)
13. (b)	14. (d)	15. (a)	16. (a)	17. (b)	18. (a)
19. (a)	20. (d)	21. (d)	22. (b)	23. (a)	24. (b)
25. (c)	26. shearing	27. axial	28. faceplate	29. forward	
30. slotter	31. vertical shaper, cutting tool	32. indexing			

## Theory Questions

- \*1. Enumerate the operations which can be performed on lathe machine.
2. Explain the various techniques to perform a taper turning on a lathe.
- \*3. What are the differences between shaper and planer?
4. Explain quick return mechanism used in shaper with neat sketch.
- \*5. Explain the working of radial drilling machine with a neat sketch.
6. Explain the stepped cone pulley drive in the lathe.
- \*7. Differentiate up milling and down milling.
8. Draw a neat diagram of the horizontal and vertical milling machine.
9. Explain feed mechanism used in a drilling machine.
10. What are the various types of milling operations, explain with the neat sketch?
11. Write short notes on counter boring, counter sinking, spot facing, and trepanning.
12. What do you mean by grinding? How it differs from milling?
13. Draw a neat sketch of the drill bit and explain all the terminology used for nomenclature.
14. Discuss the method of nomenclature of grinding wheel.
15. Explain the various methods of grinding.
16. Explain the method of centerless grinding.
17. Discuss the working of the cylindrical grinding machine with a neat sketch.
18. Discuss the working of plane grinding machine with a neat sketch.
19. Discuss the surface finishing methods with various applications.
- \*20. Write the difference between shaper and slotter machines?
- \*21. Explain the different types of grinding process with sketches.
- \*22. Draw a well-labeled neat sketch of lathe machine and state the functions of its different parts.
- \*23. Explain with figure taper turning with compound slide swiveling method.
- \*24. With the help of a neat sketch, explain the working of a universal milling machine.
- \*25. Explain with figure working principle of centerless grinding machine.
- \*26. Explain any two milling operations.
- \*27. With a neat sketch, explain the principle and operation to produce a “taper” on a lathe by tail stock set over method.
- \*28. Differentiate between the cross slide and compound slide.
- \*29. List any four differences between the horizontal milling machine and vertical milling machine.
- \*30. Differentiate between (i) Counter sinking and counter boring and (ii) Reaming and Boring.
- \*31. Explain plane milling, end milling, slot milling, with a neat sketch.
- \*32. Sketch a radial drilling machine and explain its working.
- \*33. Draw the neat sketch of the horizontal milling machine and explain parts.
- \*34. List the four elements which specify the size of the Lathe.
- \*35. With a neat sketch, explain the following lathe operations.
- \*36. Facing, Cylindrical turning, Knurling, Thread cutting.

## Learning Objectives

*By the end of this chapter, the student will be able:*

- To describe the different types of casting processes
- To demonstrate the process of pattern making, mould making, core making, and the methods of sand testing
- To describe the casting defects and their remedies
- To describe the welding as a metal joining process
- To demonstrate the different types of welding techniques with some allied processes such as soldering, brazing and braze welding
- To describe the welding defects and their remedies

## CASTING

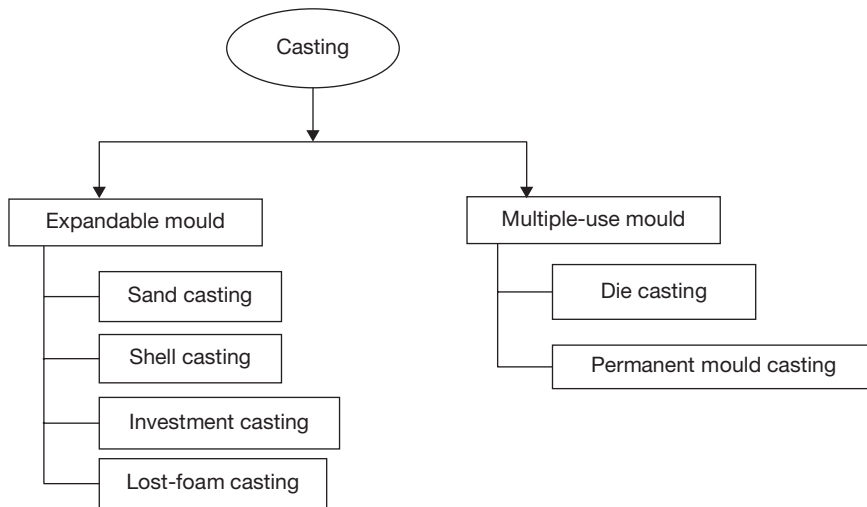
### 20.1 ► INTRODUCTION

Casting is an ancient manufacturing process. It had been used during 4000-5300 B.C. for manufacturing of copper arrowheads. In the field of casting, a number of modern technologies have been developed such as Die casting, Permanent mold casting, vacuum casting, continuous casting, electromagnetic casting, etc. but sand casting is one of the oldest casting technologies and has wider applications in the field of manufacturing technology. The use of casting parts is increasing continuously due to ease of manufacturing of complicated parts. Some metals can be shaped by casting only because of the specific metallurgical and mechanical properties. Casting is most suited for intricate shapes and for parts with internal cavities, such as engine blocks, cylinder heads, pump housing, crankshaft, machine tool beds, and frames, etc.

The casting process can be defined as a primary shaping process in which a molten metal is poured into a mold cavity and allowed to solidify for a predetermined time so as to take the shape of the mold, after complete solidification, it is taken out from the mold. The product of casting is also known as casting and the place where casting work is done is known as “foundry shop”.

## 20.2 ► CLASSIFICATION OF CASTING PROCESS

Casting process can be classified on the basis of expandable mold and multiple-use mold as shown in Figure 20.1. Expandable mold is destroyed after solidification of the casting. But, multiple-use mold can be used to make many casting. Expandable mold is used for very complicated casting design. In this process, the production rate is lower than the multiple-use mold. A multiple-use mold is used for simple casting and it has high production rate.



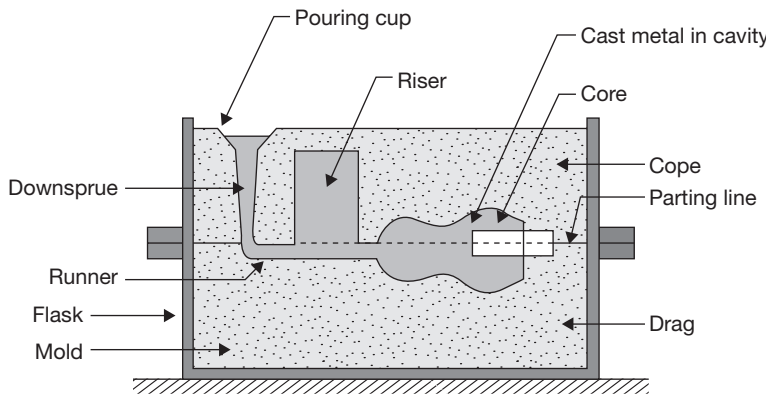
**FIGURE 20.1**

Classification of the Casting Process

## 20.3 ► SAND CASTING

A model of a mold used in sand casting is shown in Figure 20.2. Molding material—material that is packed around the pattern to provide the mold cavity is green sand. The various parts of mold can be defined as below:

**Flask:** It is a rigid box opens at top and bottom that holds the complete mold. Flask may be divided into three parts—the upper, middle, and lower; these three parts are known as cope, cheek, and drag, respectively.



**FIGURE 20.2**

A Model of Mold Used in Sand Casting

**Core:** A sand or metal shape that is inserted into the mold to create internal hole or recess.

**Mold Cavity:** It is a cavity of casting shape in the mold connected to runner and riser. It is used to pour the molten metal in which metal solidifies and gets the shape of the cavity.

**Riser:** An additional opening in the mold that provides additional metal to compensate for shrinkage and also helps to remove gas or vapor formed during pouring the molten metal into the cavity.

**Gating System:** It is a network of channels that delivers the molten metal to the mold cavity.

**Pouring Cup/Basin:** It is located at the top surface of the mold and connected to an upper part of down sprue. It prevents the splitting of molten metal.

**Downsprue:** It is a vertical portion of the gating system. It facilitates the streamline flow of molten metal.

**Runners:** It is a horizontal channel which connects the down sprue and gates.

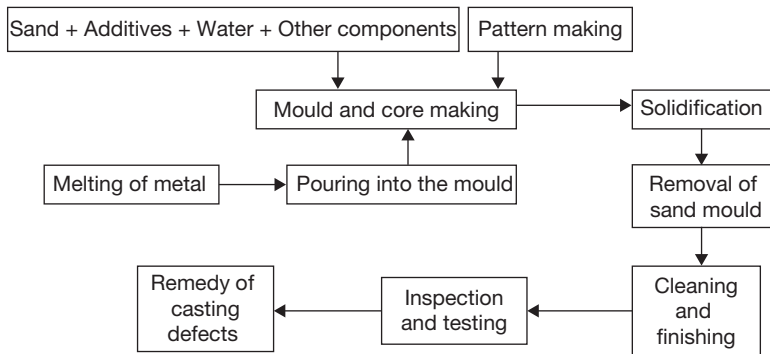
**Gate:** It controls the amount of flow of molten metal at the entrance of cavity.

**Parting Line:** It is dividing a line of Cope and drag.

### 20.3.1 Steps in Sand Casting

Sand is the most suitable material for expandable mold. It has sufficient properties of molding materials such as refractoriness, permeability, flowability, adhesiveness, cohesiveness, etc. Sand casting is most versatile and most common form of casting. In this method, a mold of sand with binding materials and water is prepared in which molten metal is poured and allowed to solidify. The entire casting process can be represented as a chain as shown in Figure 20.3.



**FIGURE 20.3**

Steps in Sand Casting

A green sand mold is prepared with the help of a pattern. The green sand mold is a mixture of green sand, binders, and water. The pattern is made of wood plastics, metal, wax, etc. The selection of pattern materials is based on the type of casting process.

After pattern/mold making, metal is melted in the cupola or in another suitable furnace. The molten metal is poured into the mold cavity. The solidification process allows the product to gain the desired properties and strength. The shrinkage in casting is controlled by the riser and proper design of the mold. After solidification, casting is removed from the mold and sent to cleaning, finishing, and inspection. Finally, the casting defects are rectified.

### 20.3.2 Pattern Making

The pattern is a replica of the product, which is to be manufactured through casting. It is used to make a mold cavity of required shape and size. Various types of pattern materials such as wood, aluminum, steel, plastic, cast iron are used in sand casting. The selections of pattern materials are based on their properties, for example, machinability, wear resistance, strength, weight, repairability, resistance to corrosion and swelling.

#### *Pattern allowances*

The surface finish of the casting product may not be as good as required, therefore, extra dimensions in the pattern are provided. The extra dimensions or extra materials provided for the pattern are known as allowances. The following allowances are provided for pattern making:

- (a) Draft Allowance/Taper allowance.
- (b) Machining allowance.
- (c) Shrinkage allowance.
- (d) Distortion allowance.
- (e) Shaking allowance/Rapping allowance.

**Draft Allowance:** To exit out the pattern from the mold easily, the surfaces of the pattern are made taper. The larger dimension side of the pattern is at the parting line. The taper provided may be  $1^{\circ}$  to  $3^{\circ}$ . When small jerk is given to pattern to exit out from the mold; air enters into the small clearance created due to the jerk and breaks the contact between pattern and mold surfaces. The inner side surface of the pattern is provided more taper angle because during solidification metal shrink towards the core. The amount of draft allowance depends on the material used for mold making the shape, the size of the pattern, etc.

**Shaking/Rapping Allowance:** To remove the pattern from the mold, the pattern is rapped with the help of draw spike so that they can be detached from the mold. But to the rapping, the cavity in the mold gets enlarged. Therefore, the pattern is made smaller than the casting, which is known as shaking allowance. This is a negative allowance.

**Machining Allowance:** The dimensional accuracy and surface finish of the casting (especially sand casting) is poor. Therefore, machining is required for good surface finish and dimensional accuracy; to compensate the removal of unwanted materials, extra materials are provided to the pattern, which is known as machining allowance. Machining allowance depends on the type of casting process, for example, machining allowance in die-casting is very small in comparison to sand casting.

**Shrinkage/Contraction Allowance:** Most of the metals occupy more volume in a molten state in comparison to solid state. When molten metal is poured into a mold cavity there is shrinkage in metal during solidification. When metal is transferred from molten state to solid state there is shrinkage and from hot solid state to room temperature solid state, there is additional shrinkage. So the volume of the pattern is larger than the casting. The extra dimension provided to the pattern to compensate the shrinkage is known as shrinkage allowance.

**Distortion Allowance:** Distortion in casting occurs in the process of cooling. It occurs due to thermal stresses developed due to differential solidification. It applies to the casting of irregular shape. To eliminate this defect, an opposite allowance of equal amount is provided in the pattern, which is known as Distortion Allowance.

### 20.3.3 Types of Pattern

- (a) Solid pattern or Single piece pattern.
- (b) Split pattern.
- (c) Loose piece pattern.
- (d) Gated pattern.
- (e) Match plate pattern.
- (f) Sweep pattern.

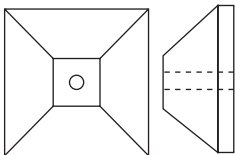
- (g) Skeleton pattern.
- (h) Cope and Drag pattern.
- (i) Segmental pattern.
- (j) Follow board pattern.

**Solid Pattern/Single Piece Pattern:** A single piece pattern is used for a simple casting. In this pattern, no joint or partition is used. It can be molded in a single molding box as shown in Figure 20.4.

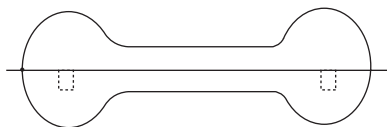
**Split Pattern:** If the design of the pattern is not simple, it difficult to withdraw as a single piece from the mold. The pattern is made into two pieces or into a split form and joined together by dowels, which is shown in Figure 20.5.

**Loose Pieces Pattern:** Some single piece patterns are made to have loose pieces in order to enable their easy withdrawal from the mold. These pieces form an integral part of the pattern during molding (Figure 20.6). After the mold it completes, the pattern is withdrawn leaving the pieces in the sand, which are later withdrawn separately through the cavity formed by the pattern.

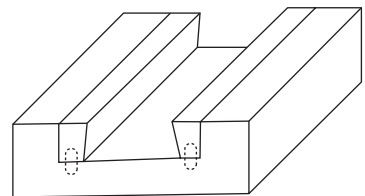
**Gated Pattern:** In a mass production, where many castings are required, gated pattern may be used. Such patterns are made of metal to give them strength and to eliminate any warping tendency. The connecting parts between the patterns from the gates or runners for the passage of molten metal into the mold cavity, are the integrated parts of these patterns (Figure 20.7).



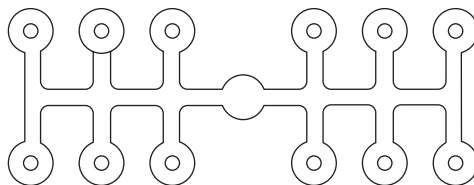
**FIGURE 20.4**  
Single Piece Pattern



**FIGURE 20.5**  
Split Pattern



**FIGURE 20.6**  
Loose Piece Pattern

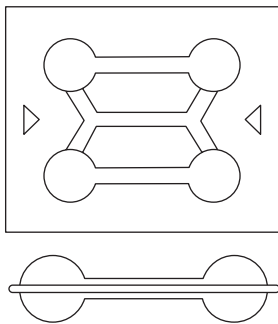


**FIGURE 20.7**  
Gated Pattern

**Match Plate Pattern:** Match plates provide a substantial mounting for patterns and are widely used with machine molding. In the Figure 20.8, a match plate is shown upon which are mounted the patterns for two small dumb bells. It consists of a flat metal or wooden plate, to which the patterns and gates are permanently fastened. On either end of the plate are holes to fit into a standard flask (Figure 20.8).

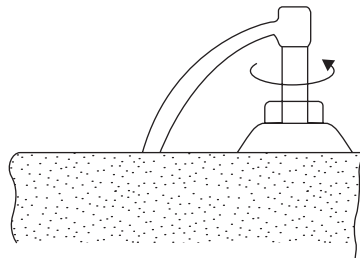
**Sweep Pattern:** Sweeps can be used for preparing molds of large symmetrical castings of circular cross-section. The sweeping equipment consists of a base, suitably placed in the sand mass, a vertical spindle and a wooden template, called a sweep. The sweep may have a different shape of casting desired. The sweep is rotated about the spindle to form the cavity (Figure 20.9). Then the sweep and spindle are removed. The filling sand patches the hole of the spindle. Cores are fitted, as required.

**Skeleton Pattern:** Skeleton pattern requires a large amount of wooden work. It is used for large size casting. A pattern consists of a wooden frame and strips, called skeleton pattern. It is filled with loam sand and rammed properly, and surplus sand is removed. Both halves of the pattern are symmetrical as shown in Figure 20.10.



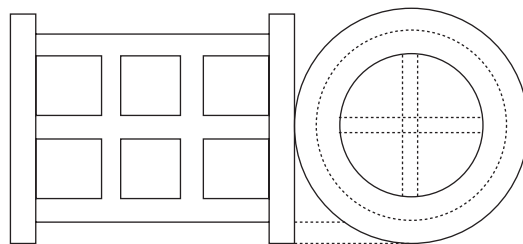
**FIGURE 20.8**

Match Plate Pattern



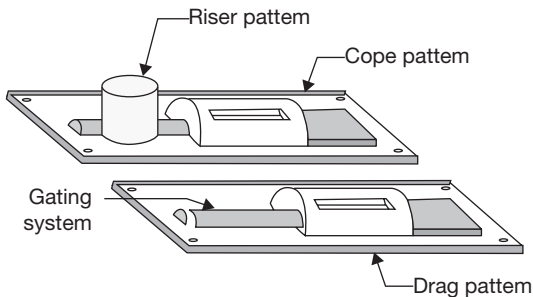
**FIGURE 20.9**

Sweep Pattern

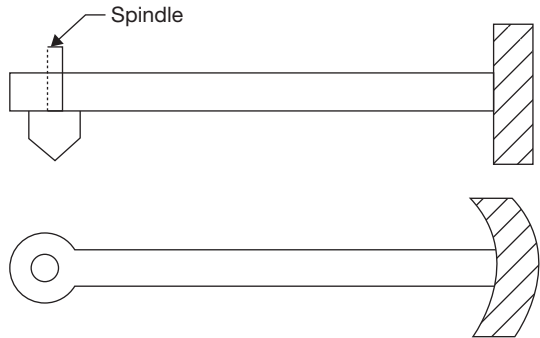


**FIGURE. 20.10**

Skeleton Pattern

**FIGURE 20.11**

Cope and Drag Pattern

**FIGURE 20.12**

Segmental Pattern

### *Cope and Drag Pattern*

Cope and drag pattern is used for heavy casting which is difficult to handle in a single piece. This pattern is made in two parts in cope and drag and finally assembled together to form a complete mold cavity (Figure 20.11).

### *Segmental Pattern*

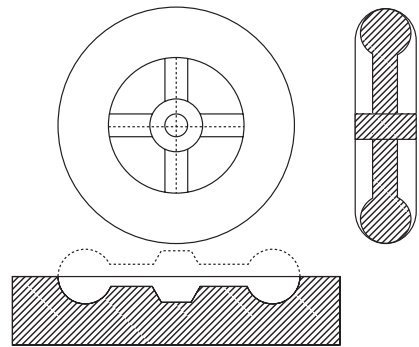
The segmental pattern is used for large ring-shaped casting (Figure 20.12). A vertical central spindle is firmly fixed near the center of a drag flask. The bottom of the mold is then rammed and swept level with a sweep. Now, with the segmental pattern is properly fastened to the spindle and in a starting position, molding sand is rammed up on the inside and outside of the pattern but not at the ends. After the surplus sand has been leveled off from its top, the segmental pattern is unfastened from the spindle, rapped and drawn. The next position for the segmental pattern will be adjoining its last position with sufficient overlap to ensure continuity. The process is continued until a complete ring-shaped mold cavity has been made. The mold may be closed with a cope or with cover cores. Sweeps and segmental patterns are widely used for making large gears, wheels, and sheaves. Cores made in one core box may be set together on a level surface to form spokes and inside surfaces of the rim and the hub. A large cast gear can be molded with a segmental pattern having only three or four teeth.

**Follow Board Pattern:** Follow board is a wooden board, which is used to support a thin section pattern. The pattern may have a cavity shape or projection shape. Due to thin section during ramming, there is a chance of breaking of pattern, therefore, a support of the same shape follow board is required which is shown in Figure 20.13.

### Color Codes Used in Pattern

Following color codes are used on the pattern for various purposes as given below:

- ▶ **Red:** Surface is to be machined.
- ▶ **Black:** Surface is to be left unmachined.
- ▶ **Yellow:** core print is to be used.
- ▶ **Black Stripes or Yellow Base:** Stop offs.
- ▶ **Clear or No Color:** Parting surface.



**FIGURE 20.13**

Follow Board Pattern

Mold making is a process of creating a replica of casting with the help of patterns and molding sand. The cavity, produced in the sand body, facilitates the molten metal to solidify and to take the shape of the cavity. Various types of molding sands used in a foundry are classified as:

**Green Sand:** Green sand is a mixture of silica sand, clay and water. Normally percentages of water and silica in the green sand are 6% and 18% respectively.

**Dry Sand:** Dry sand initially has high moisture content but the moisture has been evaporated from it by drying its mold in an oven.

**Parting Sand:** Parting sand is used on the parting plane to prevent the sticking of cope and drag part.

**Baking Sand:** This is already used sand in casting. Before reuse, it is riddled to remove all foreign materials and used to fill the molding flask after facing sand has been rammed around the pattern.

**Facing Sand:** This is freshly prepared and tempered foundry sand and it is used all around the pattern and remainder may be green sand.

### Types of Molds

Mold is a cavity of heat resistant materials into which a molten metal is poured. Sand is most suitable for mold material due to heat receptivity, permeability, and low cost but metal molds are also used for small nonferrous and precision casting. The various types of molds used in casting can be classified as:

**Green Sand Mold:** Green sand is a mixture of silica sand, clay and water. The percentages of clay and water in the mixture vary from 10% - 12% and 3% - 6% respectively. It is known as green sand due to wetness.

**Skin-dried Molds:** In this mold, the cavity surface up to a depth of  $\frac{1}{2}$  inch is dried and hard. Generally, two methods are employed to prepare a skin dried sand mold. In the first method for preparing the skin—dried mold, the sand around the pattern to a depth of  $\frac{1}{2}$  inch, is

mixed with a binder so that when it is dried it will leave a hard surface on the mold. In the second method, the entire internal surface of the mold is coated by spray or wash with linseed oil, molasses water, gelatinized starch, etc. which harden on heating.

**Dry Sand Molds:** Dry sand mold is made from coarse molding sand with a binding material. It is a mixture of green sand and cereal flour and pitch. The prepared mold is **baked** in an oven at 110 to 260°C for several hours for hardening. This type of mold is generally used for large steel castings. They give better surface finish and also reduce the incidence of the casting defects such as gas holes, blow holes or porosity. However, due to the greater strength of these molds, tearing may occur in hot-short materials.

**Loam Sand Moulds:** Loam sand molds are used for large work like Pit molding. The mold is first built with bricks or iron parts. These parts are then plastered over with a thick loam mortar, the shape of the mold is obtained with sweeps or skeleton pattern. The mold is then allowed to dry thoroughly so that it can resist the wear due to heavy rush of molten metal.

**Core Sand Molds:** Core sand molds are made from core sand in subparts and assembled together. They are made in subparts due to difficulty in handling during baking.

**Metal Molds:** Metal molds are used in die-casting of low melting temperature alloys. It may be used for ferrous and non-ferrous casting but it is more suitable for non-ferrous casting. Castings have a smooth surface finish, accurate size, and better mechanical properties and are produced with a faster rate of production. Thus, machining works are eliminated.

### Special Molds

#### (i) $CO_2$ Molds

This is also a sand molding in which water glass ( $Na_2O \cdot xSiO_2$ , Sodium silicate) is used as a binder. After the mold is prepared,  $CO_2$  is made to flow through the mold and mold gets hardened. The chemical reaction for the process is:



This is one of the methods of quick mold hardening.

#### (ii) Resin-bonded Sand Molds

In this mold, green sand mixture is mixed with thermosetting resins such as linseed oil. The resin is oxidized during baking and mold gets hardened due to polymerization.

#### (iii) Shell Molds

These molds are prepared by heating a mixture of sand and resin over the surface of a metallic pattern. This enables the production of a thin and rigid layer of uniform thickness which, when separated from the pattern surface, forms one part of the shell. Two such parts are joined to form a complete shell mold.

### 20.3.5 Properties of Mouldings Sands

**Refractoriness:** Refractoriness is a property of molding sand due to which it can withstand the high-temperature of molten metal without fusing and burning.

**Permeability:** Permeability is the ability of molding sand to escape vapor and gases formed during pouring the molten metal into the mold cavity. Due to lack of permeability, there may be casting defects like blowhole, porosity, and pinholes.

**Flowability or Plasticity:** Flowability is that property of molding sand due to which it flows uniformly into the molding box during ramming.

**Adhesiveness:** Adhesiveness is the adhering ability of the sand particles to other materials due to which the heavy sand mass is successfully held in a molding flask without any danger of its falling down.

**Cohesiveness:** This is a property of sand particles due to which it bind together firmly so that it can be easily withdrawn from molding box without damage the mold surfaces and edges.

**Collapsibility:** It is a property of the molding sand due to which mold collapses automatically after solidification of the casting to allow free contraction of the metal.

#### *Binders Used in Molding Sand*

Various types of binders used in molding sand are given as below:

**Clays:**

**Fireclay:**  $2\text{SiO}_2 \cdot \text{Al}_2\text{O}_3 \cdot 2\text{H}_2\text{O}$

**Southern Bentonite:**  $\text{Al}_{1.67}\text{Mg}_{0.33}\text{Ca}_{0.35}\text{O}_3 \cdot 4\text{SiO}_2 \cdot 2\text{H}_2\text{O}$

**Western Bentonite:**  $\text{Al}_{1.67}\text{Mg}_{0.33}\text{Na}_{0.33}\text{O}_3 \cdot 4\text{SiO}_2 \cdot \text{H}_2\text{O}$ .

**Secondary Mica Clays:**  $\text{K}_2\text{O} \cdot 6\text{SiO}_2 \cdot 3\text{Al}_2\text{O}_3 \cdot 2\text{H}_2\text{O}$ .

**Oils:** (Hardened by baking) Vegetable oil (Linseed oil), Marine animal (Whale oil), and Mineral oil (used as diluting oil).

**Synthetic Resins (Thermosetting Plastic):** Urea Formaldehyde, Phenol formaldehyde.

**Cereal Binders Made from Corn:** Gelatinized starch (made by wet milling, contains Starch and Gluten), gelatinized corn flour (made by dry milling), and dextrin (made from starch, a water-soluble sugar).

**Wood Products Binder:** Natural resin (e.g., resin, thermoplastic), sulphite binders (contain lignin, produced in the paper-pulp process), water soluble gums, resins and organic chemicals.

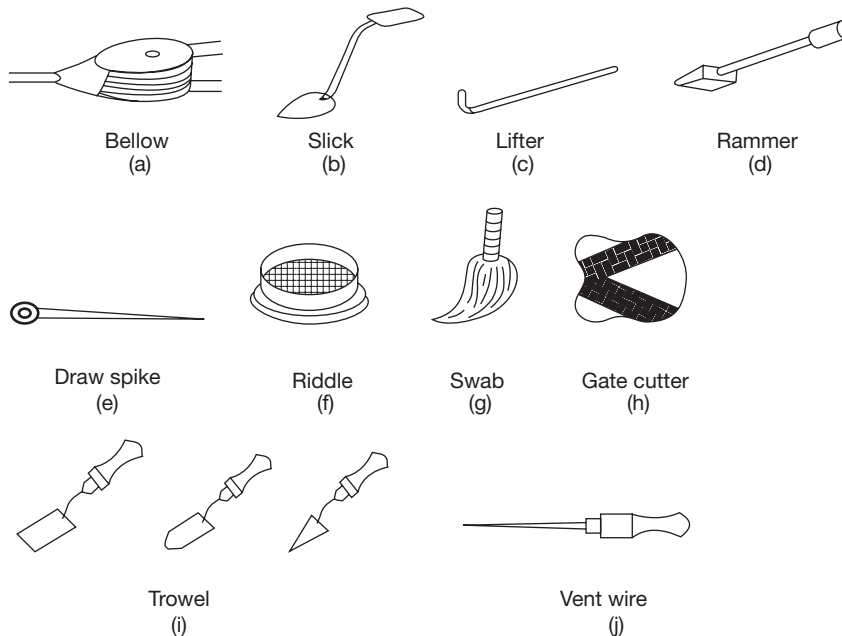
**Protein Binders (Contains Nitrogen):** Glue, casein.



**Other Binders:** Portland cement, pitch (a coal tar products), molasses, cements, sodium silicate (water glass,  $\text{Co}_2$ ).

Additives used in molding sands are coal dust, sea coal, cereals or corn flour, silica flour, wood flour, pitch, dextrin and molasses, and fuel oil.

### 20.3.6 Hand Tools Used in Moulding (Figure 20.14)



**FIGURE 20.14**

Hand Tools for Sand Molding

**Bellows:** This is used to blow out loose sand from the cavities and surface of the mold.

**Slick:** Slick is used for repairing molds is called a slick. It is a small double-ended tool having a flat on one end and a spoon on the other. It is also available in various shapes.

**Lifter:** Lifters are used for smoothing and cleaning out depressions in the mold. They are made of thin sections of steel of various widths and lengths with one end bent at right angle.

**Rammer:** A hand rammer is used to pack the sand in the mold. One edge of the rammer, called the peen end, is wedge-shaped, and the other end called butt end, is flat. Pneumatic rammers are used in large molds, saving considerable time.

**Draw Spike:** A draw spike is a pointed tool at one end and loop at another end. It is driven into a wooden pattern and withdraws the pattern from the mold.

**Riddle:** A riddle is a standard mesh screen is used to remove foreign particles from the sand.

**Swab:** A swab is a small brush having long hemp fibres, and is used for moistening the sand around the edge before the pattern is removed.

**Gate Cutter:** This is u-shaped thin metal strip, which is used to cut a gate for metal feeding into the cavity.

**Trowel:** It is available in various shapes and is used for finishing and repairing mold cavities as well as for smoothing over the casting surface of the mold.

**Vent Wire:** This is a sharp pointed wire and used to punch holes through the sand after ramming for the escape of the vapor and gases produced by pouring the molten metal.

**Cope and Drag:** Cope is the upper part of molding box. Drag is the lower part of molding box. The middle part of the molding box is known as a chick if three parts of molding box are used.

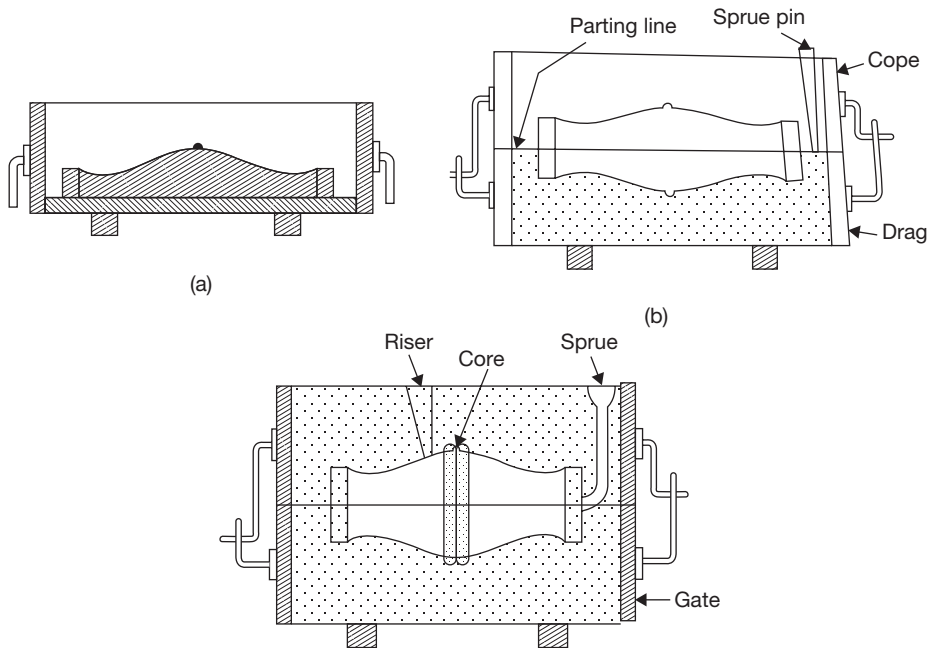
### 20.3.7 Moulding Procedure

At first, the pattern is placed on molding board, which fits the flask being used. The lower molding box is placed on the board with the pin down as shown in Figure 20.15 (a). Molding sand, which has previously been tempered, is filled over the pattern. The sand should be pressed around the pattern with the fingers then the box is filled completely. The sand is then firmly packed in drag part of the box by means of a hand rammer. For ramming the sand near of the wall of the flask the peen end rammer should be used first, additional sand being placed into the drag as the sand is settled down. The inside area of the drag is then rammed with the butt end of the rammer. The ramming should be optimum. If the mold is not sufficiently rammed, there will be a chance of breaking the mold during handling. On the other hand, it will not permit the vapor and gas to escape from the mold if it is rammed too hard.

When ramming has been completed, the surplus sand is leveled off with the help of strike-off bar. In order to ensure the escape of the gases, few small vent holes are made through the mold with the help of vent wire. The completed lower half of mold, i.e., the drag is then rolled over and the pattern is exposed. The upper surface of the mold is first smoothed over with a trowel and is then covered with a fine coating of dry parting sand to prevent the sticking of the sands in the cope.

The cope is now placed on the drag as shown in Figure 20.15 (b), the pins on either side holding it in the proper position. A sprue pin and riser is placed at the right position. The rest of the operations such as filling, ramming, and venting of the cope are repeated in the same manner as before.

Riser and sprue pin is removed. The cope half of the flask is lifted off and set to one side. Before the pattern is withdrawn, the sand around the edge of the pattern should be

**FIGURE 20.15**

Steps in Mold Making

moistened with a swab so that the edges of the mold will hold firmly together when the pattern is withdrawn.

To loosen the pattern, a draw spike is driven into it and rapped lightly in all directions. The pattern can then be withdrawn by lifting up the draw spike. Before mold is closed again, a small passage, i.e., gate must be cut from the mold at the bottom of the sprue opening. Now mold is closed for pouring the molten metal.

### 20.3.8 Gating System

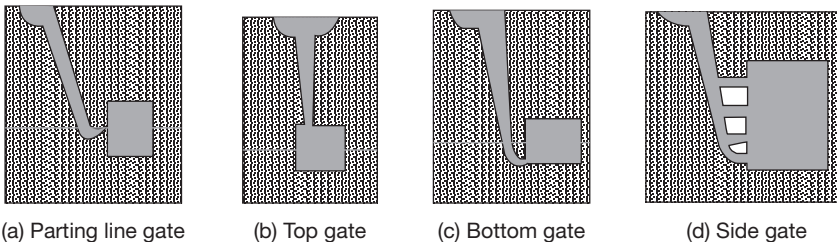
A network of the passage of molten metal from pouring basin to mold cavity is known as gating system. It consists of pouring basin, down sprue, skim bob, runner, gate, riser, etc. A good gating system should have the following properties:

- (a) Metal should enter the mold cavity with low turbulence.
- (b) Erosion of passageway should be avoided.
- (c) There should be the provision of directional solidification of metal. The solidification should progress from mold surfaces to the hottest metal so that there is always hot metal available compensate for shrinkage.

- (d) Slag or other foreign particles should be prevented from entering the mold cavity using skim bob.
- (e) There should not be aspiration problem due to poor design of down sprue.

### Types of Gates

- ▶ Parting line gate-metal enters the cavity at parting plane.
- ▶ Top gate-metal enters at top of the cavity.
- ▶ Bottom gate-metal enters from the bottom of the cavity.
- ▶ Side gate-metal enters from the side of the cavity.



**FIGURE 20.16**

Types of Gating Systems

### Risers

Risers are provided in the mold to feed molten metal into the cavity to compensate the shrinkage. In the initial stages of pouring it allows the air, steam and gases to go out of the mold. They should be large in section, so as to remain molten as long as possible and should be located near heavy sections that will be subject to heavy shrinkage and are last to freeze.

Risers used in casting may be either open type or blind type. The open riser is open to atmosphere. The blind risers are dome shaped either on the top or side of a casting. It is surrounded by the molding sand from all sides. A vent may be provided at its top. This riser may be located in either the cope or the drag. It derives its feeding force from the force of gravity on the liquid metal in it. Blind risers provide molten metal more hot in comparison to open risers.

### 20.3.9 Chills

Chills are used to improve the directional solidification with faster heat conduction by metallic chills; solidification is initiated and accelerated at desired locations. The thinner section of a casting solidifies earlier in comparison to thicker section, which results in distortion, internal stress set up, crack, etc. Chills increase the solidification rate in thicker section

and equal the solidification rate in thinner section. There are two types of chills—internal and external.

**Internal Chills:** They are located within the mold cavity and form a part of the casting. They are usually in the form of thin wires and are hung in the mold by inserting their one end into the sand.

**External Chills:** They are embedded in the mold such that they are flush with the mold walls and form a part of it. Their exposed surface is given the desired shape so that it conform to the shape of mold wall and hence of the casting.

Chills are metallic objects of high-heat capacity and high thermal conductivity which are placed in the mold/mold cavity to increase the cooling rate of castings or to promote directional solidification. These are cleaned of scale/oxide to avoid any reaction with hot metal.

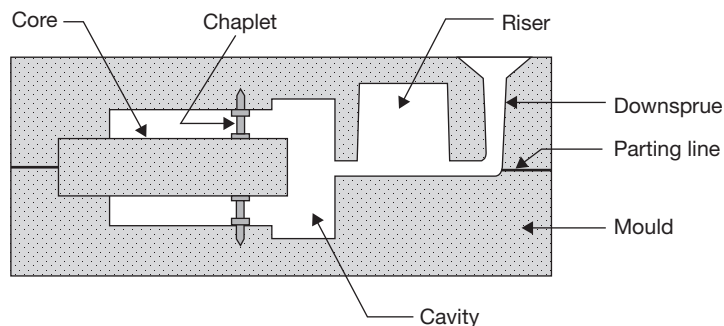
### 20.3.10 Chaplets

Sometimes, it is impossible to use core print to support the core. In this case, a metallic support is used which is known as chaplet. Chaplet is made of same material as the material of casting. It gets fused with molten metal.

Chaplets are placed in a mold between the mold face and the core as shown in Figure 20.17. It should be in such a position that its head is large enough to provide large bearing surface and stem thin to fuse properly into the molten metal.

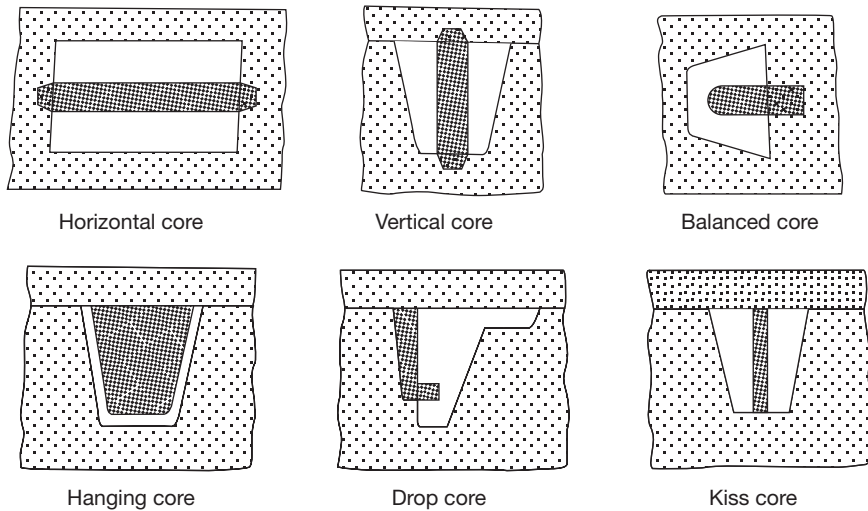
### 20.3.11 Cores

The core is a sand body specially prepared in a core box and it is used to form a cavity/hole/recess or projection in a casting for different purposes. As core is surrounded by liquid metal from all the sides, it has to have better characteristics than the molds. Better raw sand and



**FIGURE 20.17**

Use of Chaplets in a Sand Mold

**FIGURE 20.18**

Types of Cores

binder are used for the purpose. The main characteristics of the core are—highly permeable, highly refractory, hard, and high collapsible. Various types of cores are shown in Figure 20.18.

**Horizontal Core:** Horizontal core is used to provide a hole in the casting from one end to other end and lies axially horizontal. The both ends of the core are supported in the mold. Generally, it is located at parting line but its location depends on the shape. In the case of uniform core, it is located at the parting line.

**Vertical Core:** This is similar to the horizontal core but lies axially vertical. It is supported by core prints in drag and cope. It is slightly tapered and its major part lies in drag.

**Balanced Core:** This is just like a cantilever. It's one end is supported in mold and the other end is free. It is used to produce a blind hole in a casting.

**Hanging Core:** Hanging core is supported only at the top in the cope and there is no support at the bottom. The whole portion of the core lies in the cavity in the drag of the mold. It is also known as cover core since it acts as a cover for the cavity.

**Drop Core:** A drop core is required when the hole is not in line with the parting surface but must be formed at a lower level. It's one side remains flush with the inner surface of the mold and back is provided with enough taper for its location.

**Kiss Core:** Kiss core is held vertically in the mold. It is not supported by the core print. It held vertical due to the pressure of the cope and drag part of the mold.

**Core Print:** Core print is a sand body, which is used to give support to the core.

### 20.3.12 Sand Testing

Following sand testing methods are used in the foundry.

**Moisture Content Test:** To find the moisture content in the sand, moisture teller equipment is used. It consists of cast iron pan, an infrared heater bulb fitted in a shade. 20 gm sand is taken in a pan and it is exposed in infrared heater for 2 to 3 minutes. The difference in weight is found (i.e., weight before drying and weight after drying), which shows the amount of moisture.

**Clay Content Test:** Clay content in the sand is determined by washing the clay from a 50 gm of sand in water and sodium hydroxide several times. After washing sand is dried and weighed. The decrease in weight is clay content in the sand.

**Fineness Test:** According to American Foundrymen's Society Sieve Analysis, the foundry sand for its grain size is tested with the help of a sieve. The test is performed on 50g clay-free, dried sand sample. The sample is placed on the top of a series of 11 sieves having the numbers as 6, 12, 20, 30, 40, 50, 70, 100, and the sieves are shaken. The amount of sands retained on each sieve and the bottom pan is weighed and its percentage in total sample is determined. To obtain the AFS fineness number, each percentage is multiplied by a factor, which is the size of the preceding sieve. The fineness number is obtained by adding all the resulting products and dividing the total by the percentage of sand retained in the sieve set and pan.

$$\text{AFS Grain Fineness number} = \frac{\text{Sum of the products of weight of sand and sieve factors}}{\text{Total sum of the percentage retained on each sieve and pan}}$$

**Permeability Test:** Permeability is a measure of gas passes through the narrow voids between the sand grains. It is measured in terms of a number known as permeability number. Permeability number is defined as the volume of air in cubic centimeter that will pass per minute under a pressure of 10 gram per square centimetre through a sand specimen, which is 1 square centimeter in cross-section and 1 cm deep.

$$\text{Permeability number, } p = \frac{V.H}{P.A.T}$$

(Where, V = Volume of air, H = Height of specimen, P = Air pressure, A = Cross-sectional area of sand specimen, T = Time in sec.)

$$p = \frac{3007.2}{T(\text{Sec.})}$$

**Compression Test:** Compressive strength of molding sand is found by this test. A compressive load of sufficient amount is applied on a cylindrical sample of 50 mm high and 50 mm

in diameter so that it just starts to break. Sands of low moisture and excess moisture are said to have poor strength.

**Hardness Test:** Hardness test of sand mold or core is done on a hardness testing machine. It carries a hemispherical ball or tip at its bottom, which is penetrated into the mold surface. A spring-loaded shaft inside the hollow body of the instrument actuates the needle of the dial gauge fitted at the top. The dial of this gauge provides a direct reading of the mold hardness.

## 20.4 ► SPECIAL CASTING METHODS

In addition to sand casting, there are several other casting processes that are mentioned below:

### 20.4.1 Gravity/Permanent Mould Casting

In this casting method, metallic molds are used which can withstand the high-temperature of molten metal. The permanent mold is made into two parts; both parts are hinged at one end and clamped at another end. Mold is preheated before filling the molten metal. After solidification mold is opened and casting is removed. Again it is closed and used for another casting without preheating since the heat from the previous cast is usually sufficient to maintain the mold temperature.

#### *Advantages*

- ▶ Fine grain structure is obtained which results in better mechanical properties.
- ▶ Casting has a good surface finish and closer dimensional tolerance.
- ▶ Casting is free from embedded sand.
- ▶ This process is economical for large production.

#### *Disadvantages*

- ▶ This process is not suitable for small production due to the high cost of the die.
- ▶ This process is more suitable for casting of low melting point metal or alloys.
- ▶ Mold life is limited.
- ▶ A complicated shaped casting is difficult to produce by this process.

### 20.4.2 Die Casting

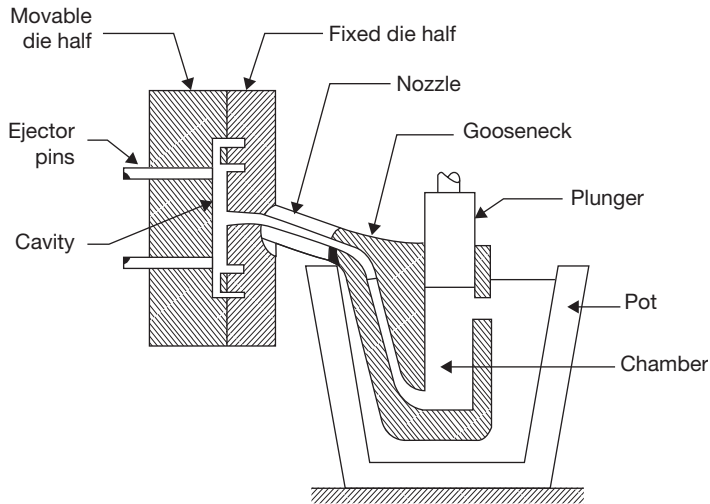
There are two types of high-pressure die-casting:

1. Hot-chamber die-casting.
2. Cold-chamber die-casting.



### Hot-chambers Die-casting

A hot chamber die-casting machine is shown in Figure 20.19. This machine is used with alloys of low melting points because of the difficulties encountered such as increased corrosion of the machine parts at high-temperatures. Since many metals have an affinity for iron, only those casting alloys are used that do not attack the immersed metal parts. Alloys of zinc, tin, and lead are particularly recommended for these machines.

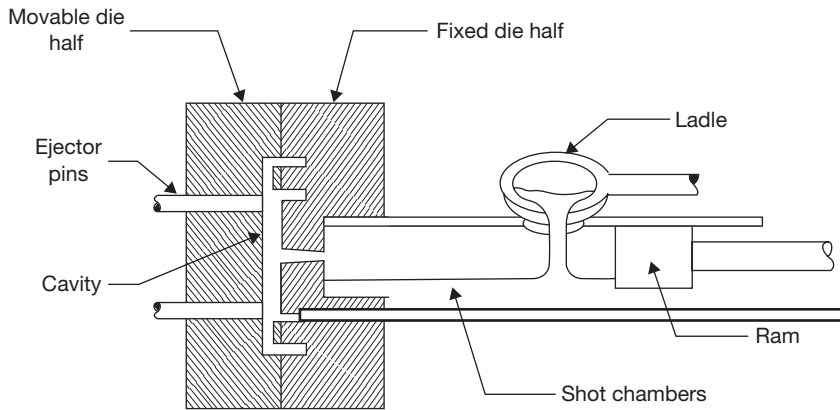


**FIGURE 20.19**  
Hot-chamber Die-casting Machine

In the hot-chamber die-casting method, the melting pot is included within the machine and the injection cylinder is immersed in the molten metal. The injection cylinder is actuated by either air or hydraulic pressure, which forces the metal into the die cavity. The metal is held under pressure until it solidifies. The improved die design and rapid cooling can reduce cycle time.

### Cold-chamber Die-casting

Cold chamber die-casting is used for relatively high melting point non-ferrous alloys such as aluminum, magnesium, and brass which require higher pressure and temperature for melting. These metals are not melted in a self-contained pot as in hot-chamber die casting due to the short life of pot (Figure 20.20). Therefore, the metal is melted in an auxiliary furnace and is ladled to the plunger cavity next to the dies. It is then forced into the dies under hydraulic pressure. The cold-chamber die casting machines operating by this method is built very strong and rigid to withstand the heavy pressure exerted on the metal as it is forced into the dies.

**FIGURE 20.20**

Cold-chamber Die-casting Machine

### *Advantages of Die Casting*

- ▶ Production rate is very high.
- ▶ Parts have good dimensional accuracy and surface finish.
- ▶ Because of high-pressure a thin wall up to 0.5 mm of casting can be produced.
- ▶ No riser is used due to the use of high-pressure injection of molten metal.

### *Limitations of Die Casting*

- ▶ Die casting has a porosity problem as gases tend to be entrapped.
- ▶ The process is economical for a large production run only.

### **20.4.3 Centrifugal Casting**

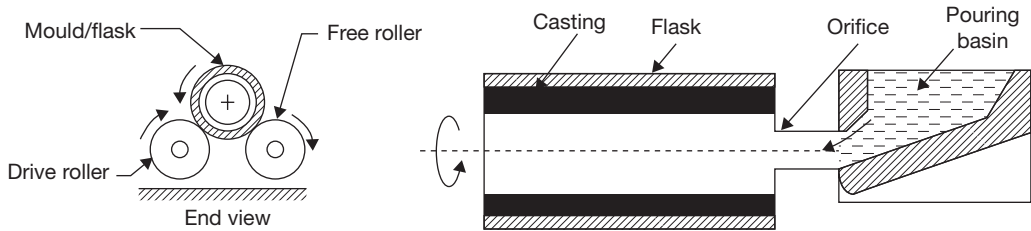
In this casting process, centrifugal force is used to feed the molten metal into the mold cavity, i.e., mold is rotated at high speed (300-3000 rpm). This process is more suitable for symmetrical shaped casting but other types of casting can also be produced. The centrifugal casting can be classified as follows:

- ▶ True Centrifugal Casting.
- ▶ Semi Centrifugal Casting.
- ▶ Centrifuging.

#### **True Centrifugal Casting**

True centrifugal casting is used for pipe, liners and symmetrical hollow body. They are cast by rotating the mold about its axis horizontally or vertically (Figure 20.21). The metal is held

against the wall of the mold by centrifugal force and no core is used to form a cylindrical cavity inside the casting. The wall thickness of the pipe produced is controlled by the amount of metal poured into the mold.



**FIGURE 20.21**

Centrifugal Casting

### Advantages

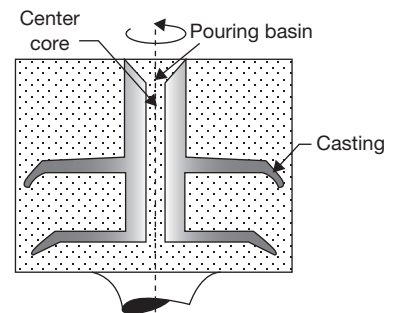
- ▶ This process produces clean casting since all foreign matter collected on the surface of the central hole can be easily removed by machining.
- ▶ The Dense metal component is produced due to centrifugal force.
- ▶ There is no need to use central core, riser, and runner.
- ▶ It can be used for large production.

### Disadvantages

- ▶ Equipment cost is high.
- ▶ True centrifugal casting is limited to certain shapes only.

### Semi Centrifugal Casting

Semi-centrifugal casting is used for the castings that are symmetrical about a central axis but complicated than true centrifugal castings. It is not necessary to have a central hole. A core will have to be employed if one is desired. The mold cavity is arranged within the mold so that its central axis will be vertical and concentric with the axis of rotation (Figure 20.22). A central sprue is provided which should be concentric with the vertical axis of rotation. Spinning speed is not as high as those used for true centrifugal casting. The general practice is to rotate these molds at the rpm, which will give linear speed at the outside edge of the castings of about 600 feet per minute.

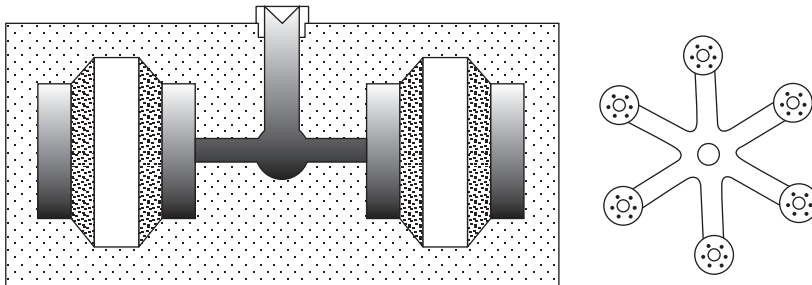


**FIGURE 20.22**

Semi-centrifugal Casting

## Centrifuging

In this process, several mold cavities are located around the outer portion of a mold, and the metal is fed to these cavities. The mold cavities are fed through radial gates provided from a central pouring reservoir by the action of the centrifugal force (Figure 20.23). Relatively low rotational speeds are required to produce sound castings with thin walls and intricate shapes. This method is not limited to symmetrical objects but can produce castings of irregular shape such as bearing caps or small brackets.



**FIGURE 20.23**

Centrifuging

## 20.5 ► CASTING DEFECTS

Casting defects are unwanted feature or irregularities in the casting which make it of poor quality. These defects occur due to several reasons such as the poor design of casting, excess moisture in the mold, improper ramming of molding sand, misalignment of cope and drag, etc. The various types of casting defects are shown in Figure 20.24.

**Shifts:** Misalignment of flask, i.e., cope and drag and mismatching of core cause shifts. These can be prevented by proper alignments and placing of the core.

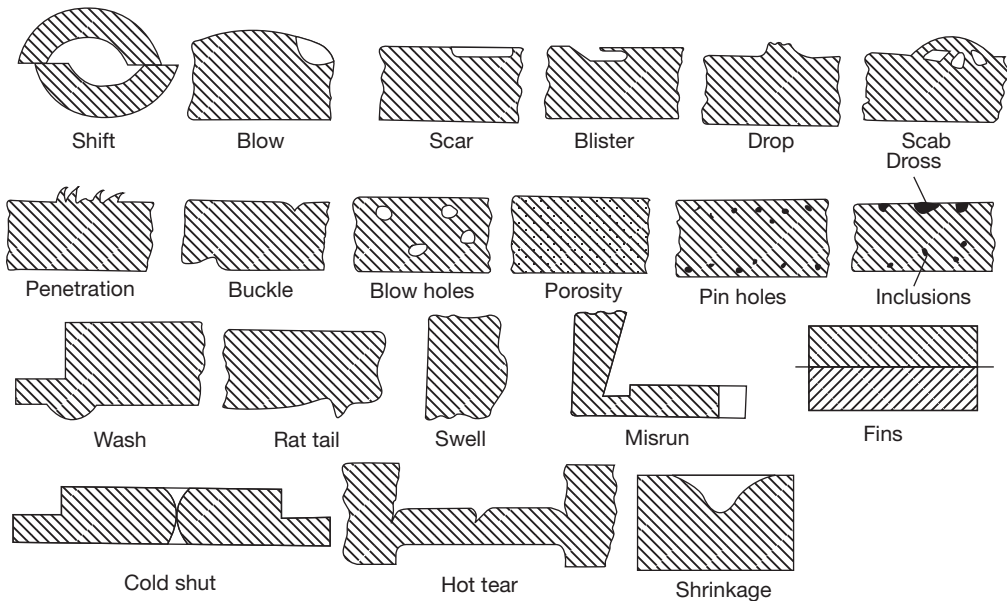
**Blow:** Blow is a small, round holes appearing at the surface of the casing covered with a thin layer of metal.

**Scar:** It is a shallow blow, which is usually found on a flat casting surface.

**Swell:** Swell is an enlargement of the mold cavity due to metal pressure. It caused due to defective ramming of the mold. To avoid swells, the sand should be rammed properly and evenly.

**Blister:** This is scar covered by a thin layer of a metal.

**Drop:** When the upper surface of the mold cracks and pieces of sand fall into the molten metal, this defect occurs. This is caused by low strength and soft ramming of sand,

**FIGURE 20.24**

Casting Defects

insufficient fluxing of molten metal and insufficient reinforcement of sand projections in the cope.

**Scab:** Liquid metal penetrates the surface layer of sand. Scabs can be identified as rough, irregular projection on the surface containing embedded sand. They are caused using too fine sand, sand having low permeability and high moisture content, and by uneven mold ramming or slow running of molten metal over the sand surface thereby producing intense local heating.

**Metal Penetration and Rough Surface:** This defect appears as an uneven and rough external surface of the casting. The metal penetration between the sand grains occurs due to low strength, large grain size, high permeability and soft ramming of sand.

**Buckle:** This defect is similar to the rat-tail but differs from it in the sense that it is in the form of V-shaped depression in the surface of the casting.

**Blowholes:** Blowholes are smooth, round holes appearing in the form of a cluster of a large no. of small holes below the surface of a casting. Possible causes are excess moisture in the molding sand, moisture on chills, chaplets, and insufficiently baked and improperly vented core.

**Porosity:** Porosity is entrapped gases in the form of fine small bubbles throughout the casting.

**Pinholes:** Pinholes are numerous small holes, usually less than 2 mm, visible on the surface of the casting cleaned by shot blasting. They are caused by sand with high moisture content, absorption of hydrogen or carbon monoxide gas or when steel is poured from wet ladles.

**Inclusions:** Inclusions is mixing of foreign particles such as sand and slag in the casting.

**Wash:** It is a low projection on drag surface of a casting starting near the gate. This results due to the displacement of sand by the high-velocity metal in the bottom part of gating.

**Rat-tails:** These defects appear as streaks or slight ridges on large flat surfaces. They occur due to the expansion of sand by the heat of the molten metal.

**Mis-run:** A mis-run is the incomplete filling of the mold that results when the metal lacks fluidity or temperature.

**Fins:** Fins usually occur at the parting line of the mold or core sections due to improper clamping of the flask. The remedy is to give sufficient weight on the top for proper assembly of the flasks and molds.

**Cold Shut:** It is the type of mis-run occurs in the center of a casting having gates at its two sides. Imperfect fusion is a result of from low-temperature of two streams of metal.

**Hot Tears:** They are internal and external cracks having a ragged edge occurring immediately after the metal has solidified. Hot tears may be produced if the casting is poorly designed and abrupt change in sections take place, no proper fillets and corner radii are provided, chills are wrongly placed. Incorrect pouring temperature and improper placement of gates and risers are used.

**Shrinkage Cavity:** Shrinkage cavity is a void or depression in the casting caused mainly by uncontrolled solidification of the metal. The may also be produced if pouring temperature is high.

## 20.6 ► SURFACE CLEANING OF THE CASTING

**Wire Brushing:** Wire brush of hardened steel wires, embedded in a wooden block, is extensively used for cleaning the casting surface.

**Tumbling:** In this method, the castings to be cleaned are placed together with a number of small cast iron pieces called stars inside a large steel barrel. Both ends of the barrel are closed and the same rotated along a horizontal or inclined axis for about half an hour. The casting, during this period of rotation, rubs against each other and the sand particles, scale, etc., are separated out from the surface of the casting.

**Sand Blasting:** In this method, a stream of high-velocity air carrying large grain size of sand particles is thrown onto the surface of the casting. The abrasive sand removes the dirt, sand, and scale from the surface of the casting.

**Shot Blasting:** This method is similar to sand blasting, but here metallic abrasives are fed into the air blast instead of sand grains.

**Hydro Blasting:** In this method, a high-velocity stream of water and sand is thrown on the casting surface with a speed of about 100 m/sec, which removes the dirt, sand, and scale from the casting surface.

**Pickling:** In this process, an acid is used for cleaning the sand from casting surface. For brass castings nitric acid and for iron castings hydrofluoric acids are commonly used. In order to neutralise the acid remaining on the surface, it is necessary that the acid pickled casting should be dipped in an alkaline solution, followed by dipping in water.

## WELDING

### 20.7 ► INTRODUCTION

The history of joining metals goes back several thousand years, with the earliest examples of welding from the Bronze Age and the Iron Age in Europe and the Middle East. Welding was used in the construction of the iron pillar in India, during the Ashoka empire. In an ancient age, forge welding was in use but welding technology has been developed in the advanced form in the 19<sup>th</sup> and 20<sup>th</sup> century. Electric arc welding was proposed in 1800 when Sir Humphry Davy discovered the electric arc. Advances in arc welding continued with the invention of metal electrodes in the late 1800s by a Russian, Nikolai Slavyanov, and an American, C. L. Coffin, even as carbon arc welding, which used a carbon electrode. Around 1900, A. P. Strohmenger released a coated metal electrode in Britain, which gave a more stable arc, and in 1919, alternating current welding was invented by C. J. Holslag. The main aim of explaining the welding processes in this chapter is to introduce the most basic welding processes used in joining of various metals.

#### 20.7.1 Definition of Welding

A weld is defined by the American Welding Society (AWS) as “a localized coalescence (the fusion or growing together of the grain structure of the materials being welded) of metals or nonmetals produced either by heating the materials to the required welding temperatures with or without the application of pressure, or by the application of pressure alone, and with or without the use of filler materials”

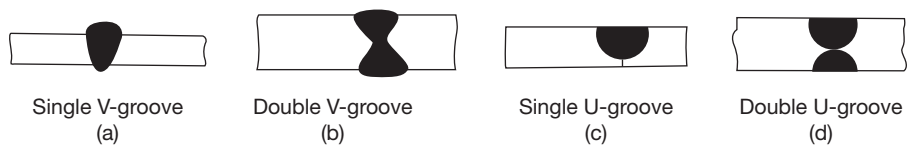
Welding is a joining process that produces coalescence of materials by heating them to the welding temperature, with or without the application of pressure alone, and with or without the use of filler material. This is a permanent joint. It cannot be disassembled easily. The ability of a metal to be welded easily is known as Weldability.

Weldability is ability or property of a metal due to which it can be easily welded. It depends on the following factors:

1. Heat applied during the welding process.
2. Welding process, i.e., types of welding used to make the joint.
3. Thermal conductivity of the work materials.
4. Constituents of the materials.
5. Melting point of the parent metal.

### Types of grooves

For complete penetration, sound welded joints, and good strength, beveling preparation of edges and cleaning are required. The type of groove or edge preparation depends on the thickness of the plate and the welding methods. Some of the edge preparation methods are shown in Figure 20.25.



**FIGURE 20.25**

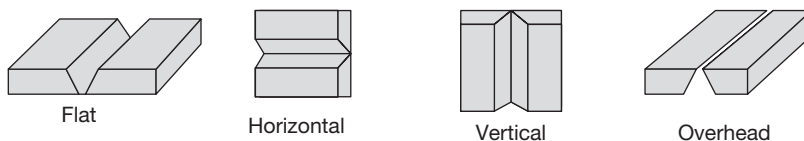
Edge Preparation in Welding

The use of various types of grooves varies with the thickness of metal plates as discussed below:

- ▶ Thickness ( $t$ )  $<$  6 mm—no edge preparation is required.
- ▶ 6 mm  $<$   $t$   $<$  16 mm—Single-V-groove.
- ▶  $t$   $>$  16 mm—Double-V-groove.
- ▶  $t$   $>$  20 mm—Single- and Double-U-groove.

**Types of welding positions:** According to welding position the welding can be classified as flat, horizontal, vertical, and overhead welding as shown in Figure 20.26. For different positions of the welding, different methods of welding are used as per suitability.

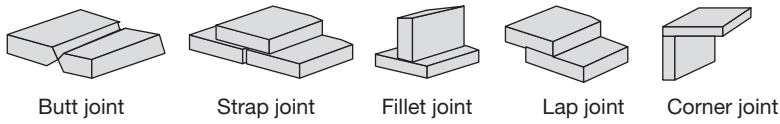
**Types of welded joints:** According to the relative position of two pieces of metal, which are to be joined, five types of weld joints are used in welding as shown in Figure 20.27.



**FIGURE 20.26**

Various Positions of Welding



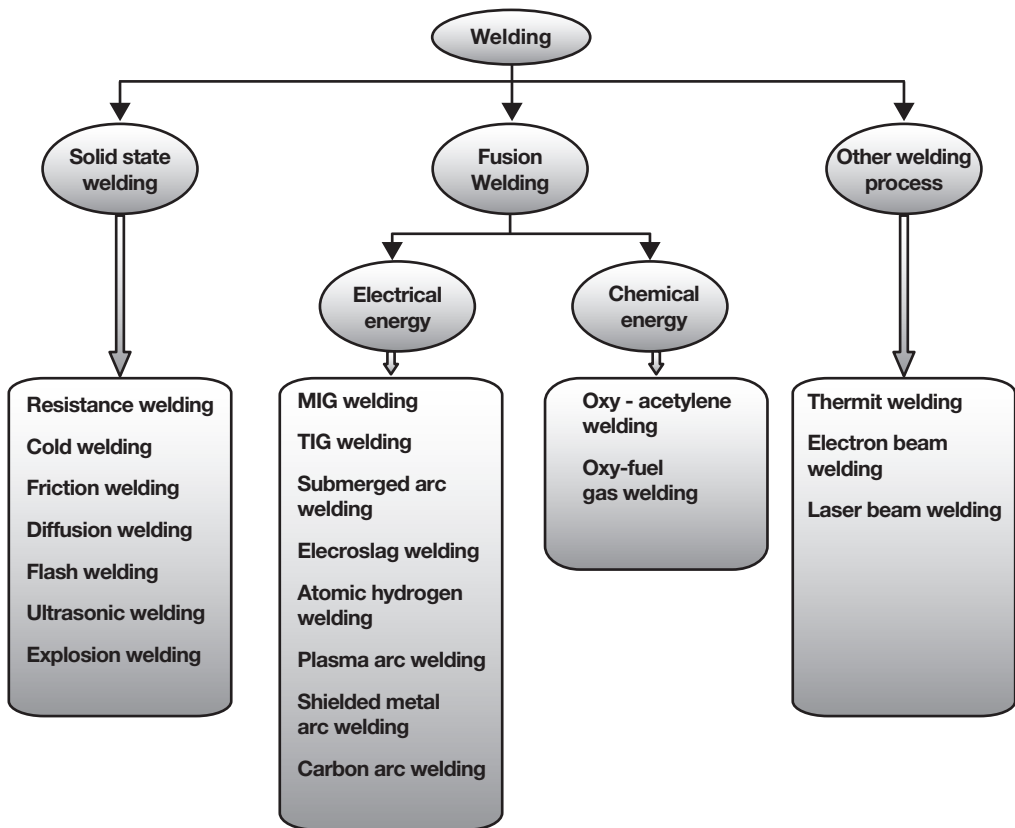


**FIGURE 20.27**

Five Basic Types of Welded Joints

## 20.8 ► CLASSIFICATION OF WELDING PROCESS

Broadly, welding processes can be divided into the following categories as shown in Figure 20.28.



**FIGURE 20.28**

Classification of Welding Processes

## 20.9 ► GAS WELDING

In this welding process, various types of gases are burnt in combination with oxygen and the flame is applied at the edge of metal plates to be joined. The heat of combustion of the gas melts the metal; filler material may or may not be applied to fill the groove. The molten metal fills the groove which after complete fusion and solidification forms a strong joint. External pressure may or may not be applied at the joint.

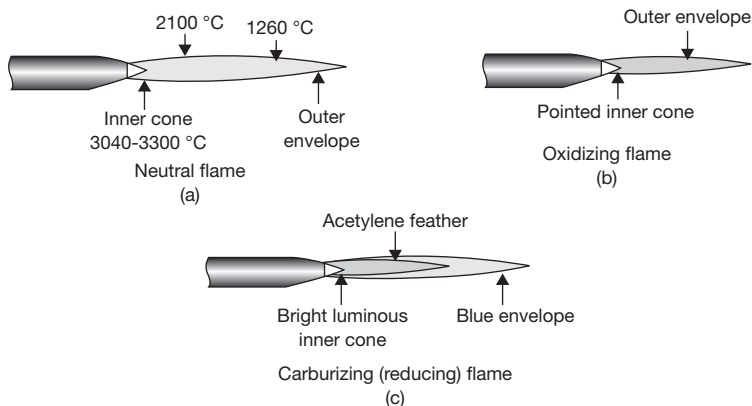
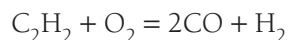
The different types of gases used in gas welding are: 1. Acetylene; 2. Hydrogen; 3. Methane; 4. City gas; 5. Natural gas; etc. The most commonly used gas is acetylene, as acetylene gives highest flame temperature because of its high calorific value.

### 20.9.1 Oxyacetylene Welding

The highest temperature obtained in oxy-acetylene welding is 3200°C. Acetylene can be used as a gas from a separate cylinder or through reaction of water on calcium carbide. Three different types of flames such as neutral, oxidizing, and carburizing, are generated at the tip of welding torch by regulating the amount of acetylene and oxygen with the help of pressure regulators and control valve. These flames are shown in Figure 20.29.

**Neutral Flame:** Neutral flame is generated at the tip of the welding torch with an equal volume of oxygen and acetylene mixing in the torch. The two sharply defined zones are inner white cone and outer blue envelope. The maximum temperature occurs at a distance of 3 to 5 mm from the inner cone.

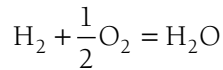
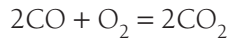
The reaction at the inner cone is:



**FIGURE 20.29**

Three Basic Types of Flames Used in Oxyacetylene Gas Welding and Cutting Operations: (a) Neutral Flame; (b) Oxidizing Flame; (c) Carburizing or Reducing Flame.

The reactions at outer envelope are:



The outer envelope works as a protector and pre-heater of the workpiece. The metals using a neutral flame for welding are—cast iron, mild steel, stainless steel, copper, aluminum, etc.

**Oxidizing Flame:** Oxidizing flame is generated with a higher proportion of oxygen. The proportion of oxygen and acetylene used is 1.15–1.5. The flame is similar to neutral flame but the inner cone is shorter than that of neutral flame; the outer envelope is light blue. In this flame, there is complete combustion of acetylene and forms carbondioxide and water vapor. This is oxidizing in nature and used in welding of brass, zinc, bronze, and gold, etc.

**Reducing Flame or Carburizing Flame:** In this flame, acetylene is used in excess amount than the theoretically required. The ratio of oxygen and acetylene used is 0.85 to 0.95. The three zones in this flame are—the inner cone, which is not sharply defined; the outer envelope is similar to neutral flame; the third zone surrounding the inner cone extends up to the outer envelope. It is whitish color and shows the excess of acetylene used. This flame is used for welding of low carbon steel, aluminum, non-ferrous metals like Monel metal, nickel, etc.

**Oxyacetylene Welding Equipments:** Following equipments are used in oxy-acetylene welding (Figure 20.30):

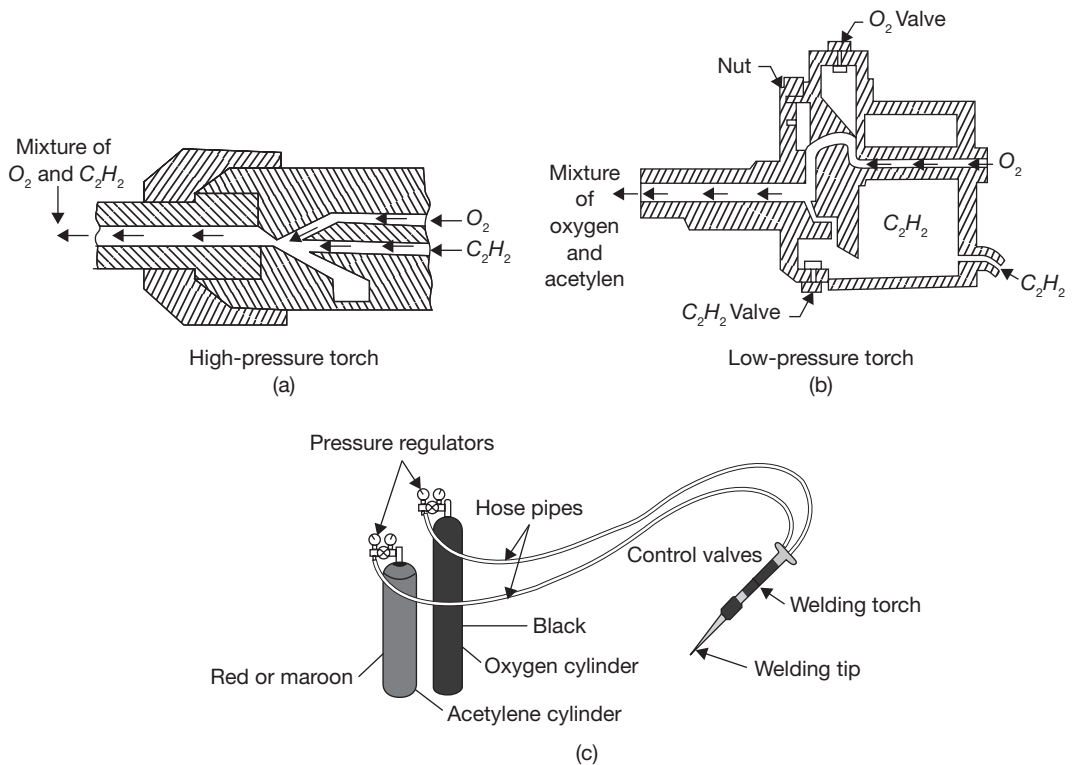
**Gas Cylinders:** Two gas cylinders made of steel are used. One is of black color used for oxygen and other is of maroon or red color used for acetylene.

**Pressure Gages:** Each cylinder consists of two pressure gages. One pressure gauge shows the pressure of the gas inside the cylinder and other shows pressure of the gas supplied to blowpipe.

**Pressure Regulator:** Each cylinder is provided with a pressure regulator. The function of the pressure regulator is to control the pressure of gas supply to blowpipe or to maintain the constant pressure of the gas.

**Blowpipe or Welding Torch:** the cross-sectional view of welding torches are shown in Figure 20.30 (a) and (b) as high-pressure welding torch and low-pressure welding torch, respectively.

The high-pressure blow pipe consists of two passages—one is for oxygen and other is for acetylene. Both the gases are mixed in a chamber and then driven out through the orifice of the blowpipe nozzle with the desired velocity. These nozzles are usually known as tips and are made interchangeable so that the same blowpipe can be used for different sizes of the tips.

**FIGURE 20.30**

(a) Cross-sectional View of the High-pressure Torch, (b) Cross-sectional View of the Low-pressure Torch, (c) Basic Equipment Used in Oxyacetylene Gas Welding.

The low-pressure torch works on the principles of the injector. The pressure of acetylene used is too low but oxygen is supplied at high-pressure from 7 to 50 psi.

**Note:** Acetylene cannot be filled alone in a cylinder due to dissociation at high-pressure so it is mixed with small amount of acetone. For mixing at atmospheric pressure, 25 liters of acetylene is mixed with 1 liter of acetone.

### Advantages

- ▶ The equipment used in oxy-fuel welding is less costly and easily maintainable.
- ▶ It is portable and can be used anywhere.
- ▶ It can be used to join most of the common metals.
- ▶ The flame temperature can be easily controlled.
- ▶ This can be used for cutting purposes.

### Limitations

- ▶ Due to lack of concentration of heat, a large area of the metal is heated and distortion is likely to occur.
- ▶ Oxygen and acetylene gases are expensive.
- ▶ Storing and handling of gas cylinders involve greater safety measures.

Flux and shielding provided in oxy-acetylene welding is not so effective as in inert gas arc welding.

**Welding Rod and Fluxes:** Welding rod used in a gas welding has a similar composition to work material. The diameter of welding rod depends on the thickness of the metal plate. Generally, the diameter of welding rod used is half of the thickness of the plate. To increase the fluidity of molten metal and to protect the weld pool from the atmospheric gases, fluxes are used. Various types of fluxes are used to weld the different types of metals but for mild steel, no flux is required. The type of fluxes used, depending on the type of metal to be welded, which are listed below.

1. **Copper and Copper Alloys:** Mixture of sodium and potassium borates, carbonates, chlorides, sulphates, borax ( $\text{Na}_2\text{B}_4\text{O}_7 \cdot 10\text{H}_2\text{O}$ ), Boric acid ( $\text{H}_3\text{BO}_3$ ) and Di-sodium hydrogen phosphate ( $\text{Na}_2\text{HPO}_4$ ) are used for dissolving oxides of copper.
2. **Ferrous Metals**
  - *Carbon steel:* Dehydrated Borax, calcium oxide, dissolved in liquid.
  - *Alloy steel:* Boric acid, dehydrated borax, calcium fluoride.
3. **Aluminum and Aluminum Alloys:** Mixture of alkaline fluorides, chlorides and bisulphate of calcium, sodium, potassium, lithium and barium.

## 20.9.2 Gas Welding Methods

There are two types of welding methods.

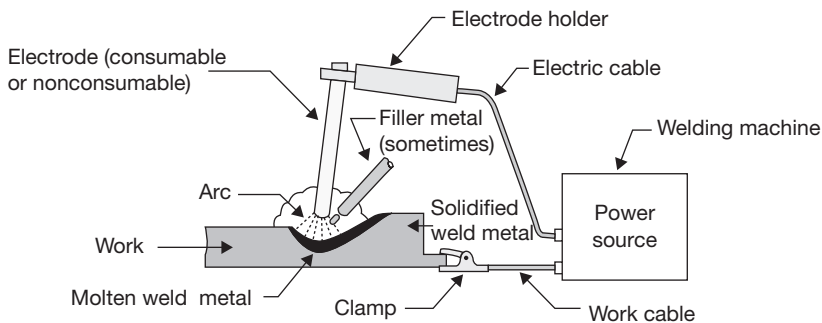
1. Leftward welding (Forehand welding).
2. Rightward welding (Backhand welding).

The welding rod is held in left hand and blowpipe is held in right hand. Leftward welding is used for the metal plate thickness up to 3 mm. Welding proceeds from right to left. It is also known as forward or forehand welding. The inclination of welding rod with the plate is 30-40 and inclination of blowpipe with the plate is 60°–70°.

Rightward welding is used for thicker plates and proceeds from left to right. The inclination of welding rod is same as in the leftward welding but the inclination of blowpipe is 10-20 less than that in the leftward welding, i.e., at 40°–50°. It is also known as backward or backhand welding.

## 20.10 ► ELECTRIC ARC WELDING

In electric arc welding, the heat required for melting the metal is generated by short-circuiting the electrodes. An intense heat is produced in the electric arc. Various types of mechanism are used to produce arc and to stabilize it. The selection of the mechanism, i.e., type of electric arc welding depends on the heat required to melt the metal. A schematic diagram of an electric arc welding is shown in Figure 20.31.



**FIGURE 20.31**

Schematic Diagram of an Electric Arc Welding

**Mechanism of Arc Generation:** When two electrodes are brought into contact with each other, electric spark is produced due to short-circuiting. Just after sparking, the electrodes are separated by 2 to 4 mm distance. The air-gap between the electrodes is ionized due to the flow of electron from the cathode to anode and heavier positive ion from the anode to the cathode. Thus, the arc is continued. The arc length is 0.6 to 0.8 of the electrode diameter.

**Modes of Metal Transfer in Arc Welding:** There are numbers of forces dominant in arc welding, which are responsible for the metal transfer. These forces are—gravity force, surface tension, electromagnetic interaction, and hydrodynamic action.

**Methods of Arc Generation:**

1. Between consumable electrode and workpiece.
2. Between two non-consumable electrode and workpiece.
3. Between a non-consumable electrode and workpiece.

Consumable electrode produces an arc between the electrode and work metal as well as works as a filler material, which fills the groove. During welding, it is consumed and its length decreases. But non-consumable electrode only produces the arc and additional filler

material is used in the form of a rod if it is required. When two non-consumable electrodes are used; the arc is produced between these electrodes and workpiece is not connected with the electric circuit. The workpiece and filler rod get heat for melting from the arc produced between these two electrodes. When a single, non-consumable, electrode is used, the electrode and workpiece are connected with electric terminals.

**Polarity:** Polarity is a connection of the electrodes and work metal with particular electric terminals. Polarity is significant in only D.C. supply. Two types of polarity are used:

1. Straight Polarity.
2. Reverse Polarity.

In the case of straight polarity, the workpiece is connected with positive terminal and electrode is connected with negative terminal. About 70% of heat is produced at positive terminal only 30% of heat is produced at the negative terminal. If heat required for welding is large, the straight polarity is used.

In the case of reverse polarity, the workpiece is connected with negative terminal and electrode is connected to the positive terminal. Reverse polarity is used for large groove size, i.e., for more metal pilling.

**Table 20.1: Differences between A.C. and D.C. Welding**

A.C. Welding	D.C. Welding
<b>Advantages:</b>	<b>Advantages:</b>
<ol style="list-style-type: none"> <li>1. Equipment of A.C. welding is less expensive, light in weight, easy maintainable and having low operating cost.</li> <li>2. It has higher efficiency in comparison to D.C. welding (85%).</li> <li>3. It consumes low electrical energy per Kg of metal deposited (3 to 4 kwh / Kg).</li> <li>4. Minor magnetic arc blow problem occurs in comparison to D.C. welding.</li> </ol>	<ol style="list-style-type: none"> <li>1. It has higher arc stability than that of A.C. welding.</li> <li>2. The Bare electrode can be used easily.</li> <li>3. It has high power factor (0.6 to 0.7).</li> <li>4. Facility of change of polarity is done easily.</li> </ol>
<b>Disadvantages:</b>	<b>Disadvantages:</b>
<ol style="list-style-type: none"> <li>1. It has low power factor. (0.3 to 0.4).</li> <li>2. For stability of the arc, voltage/ frequency requirement of A.C. current is high.</li> <li>3. Only coated electrodes can be used with A.C. If bared electrode is used, shielding gas must be there to keep the continuous ionized path of the arc.</li> </ol>	<ol style="list-style-type: none"> <li>1. It has low efficiency (30 to 60%).</li> <li>2. It involves high cost of equipment and operation.</li> <li>3. It consumes high power (6 to 10 KWH / Kg of metal deposited).</li> <li>4. Chances of the magnetic arc blow problem are more.</li> </ol>

**Magnetic Arc Blow Problem in D.C. Welding:** Magnetic arc blow problem occurs when the magnetic flux surrounding the electrode and workpiece becomes unbalanced. In this

problem, arc deflects from its path; it occurs generally at the end of the workpiece or in the corner welding. Due to the flow of electric current in the electrode and workpiece, a magnetic field is established around the workpiece and electrode in the direction perpendicular to the direction of flow of electric current. Due to deflection in the path of the arc, heat is not concentrated at the proper location. This problem is circumvented in A.C. welding as the polarity keeps changing and also the direction of magnetic flux.

**Methods to Minimize Magnetic Arc Blow Problem:**

1. Use A.C. in place of D.C. if it is possible.
2. Reduce the current and the arc length.
3. Ground connection of the welding joints.
4. For reduction of backward arc blow, the ground connection should be placed at the start of the weld.
5. For reduction of forward arc blow, the ground connection should be placed at the end of the weld.

**Types of Electrodes:** Two types of electrodes are used in electric arc welding as:

1. Coated electrode.
2. Bare electrode.

Coated electrode consists of a coating of the flux of various ingredients on its surface. The coating is generally used for arc stability. Normally, sticks of electrodes are available in the sizes of 3.2, 4, 5, 6, 8, 9, and 12 mm of diameter and 350 mm or 450 mm in length. In the case of coated electrodes, the diameter is measured in the bare portion, i.e., without coating.

### 20.10.1 Functions of Electrode Coatings

1. To stabilize the arc:
2. To provide a gaseous atmosphere for protection from atmospheric gases like O, H, N, etc.
3. To remove impurity in the form of slag. Slag also protects the molten pool of metal and reduces cooling rate.
4. To reduce spatter of weld metal.
5. Acts as deoxidizer, i.e., reduces the melting point of metal oxide.
6. To include or add the alloying elements.
7. To insulate the electrode.
8. Slow down the fast cooling rate of the weld.
9. Increase the deposition efficiency.



### 20.10.2 Ingredients of Electrode Coating

1. Ingredients for slag formation—Asbestos, fluorspar, mica, silica, titanium dioxide, iron oxide, calcium carbonate, aluminum oxide, magnesium carbonate, etc.
2. Ingredients for arc stabilization—Feldspar, sodium oxide, magnesium oxide, calcium oxide, mica, potassium silicate.
3. Ingredients for deoxidizing metal oxide—Cellulose, calcium carbonate, dolomite, starch, dextrin, wood flour, graphite, aluminum, ferromanganese.
4. Ingredients for binding—Sodium silicate, potassium silicate, asbestos.
5. Ingredients for improvement in strength of weld—TiO, Iron power.
6. Ingredients for gas formation—Cellulose, carbohydrate, etc.

### 20.10.3 Selection of Electrodes

Selection of electrodes is based on the following factors:

1. Composition of the base metal.
2. Thickness of base metal.
3. Depth of penetration required.
4. Welding position.
5. Use of A.C. or D.C.
6. Mechanical strength required for the joint.

### 20.10.4 Specifications for Electrodes

There is not a fixed rule of coding for bared electrodes. But there is six digit code is used for the specification for the coated electrodes. The six digit code has a prefix and suffix letter. For example: **E423413H**

1. The first suffix letter shows the method of manufacturing of electrode. This may be solid extrusion–E or extruded with reinforcement–R.
2. The first digit (1–7) shows the types of coating, i.e., the high content of the coating.
3. The second digit (0–4) shows the position of welding.
4. The third digit (0–4) shows the electric current conditions (A.C. or D.C.), polarity and voltage required.
5. The fourth and fifth digit shows the yield stress. For example, 41 show its yield strength 410 to 510 N/mm.
6. The sixth digit shows the percentage elongation with impact strength.
7. Suffix letters show the special properties of the electrode.

## 20.11 ► TYPES OF ELECTRIC ARC WELDING

Various types of electric arc welding process explained in this book are given below as:

1. Carbon arc welding.
2. Metal arc welding.
3. Metal inert gas arc welding (MIG).
4. Tungsten inert gas arc welding (TIG).
5. Submerged arc welding.
6. Electroslag welding.
7. Atomic hydrogen welding.
8. Plasma arc welding.

### 20.11.1 Carbon Arc Welding

Carbon arc welding is a very old method, which is still in use today. In this welding process, two electrodes of graphite or one electrode as graphite and another electrode as workpiece may be used for arc creation. Carbon arc is easily affected by a magnetic field, therefore for arc stabilization, a separate magnetic field is built in the electrode holder. A separate filler rod may be used to fill the groove. Carbon arc welding is done in as an automatic welding machine in which current, voltage, feed rate are properly controlled. In this process, the joint becomes very hard due to automatic addition of carbon from graphite electrodes. Therefore, this is used for welding of cast iron, steel, copper, bronze, galvanized iron, and aluminum. Only D.C. and straight polarity is used in this welding process.

#### *Advantages*

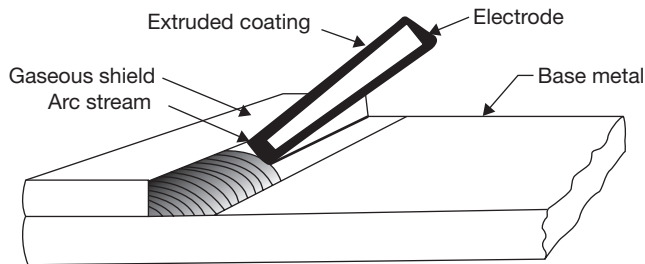
- Very simple equipment is used which involves low cost.
- Less skilled labor may be employed.
- It can be easily automated with controlling current, voltage, and feeding rate.

#### *Limitations*

- The disintegrated electrode can transfer carbon to the workpiece making the weld brittle and unsound.
- The process often results in blow holes and porosity, which are caused by the turbulence in weld pool due to the arc blow problem.

### 20.11.2 Shielded Metal Arc Welding (SMAW)

In this welding process, a special electrode that consists of metal wire which has bonded coating containing flux of desired gradients. The heat required for welding is generated

**FIGURE 20.32**

Shielded Metal Arc Welding

by an arc between the flux covered consumable electrode and the workpiece. The process is shown in Figure 20.32. As the coating on the electrode melts and vaporizes, it forms a protective layer of gases that stabilizes the arc and protect. Flux also reacts with impurities of the metal and forms slug which floats on the surface of the molten metal and protects from contamination of atmospheric gases. After solidification, the slug is chipped out from the weld.

### *Advantages*

- ▶ The equipment required is simple, portable, and less expensive.
- ▶ Welds can be used in all positions.

### *Disadvantages*

- ▶ The process has to change the electrode frequently due to consumable in nature.
- ▶ Low melting metals such as zinc, lead, and tin are not welded by SMAW.

## 20.11.3 Metal Inert Gas Arc Welding (MIG)/Gas Metal Arc Welding (GMAW)

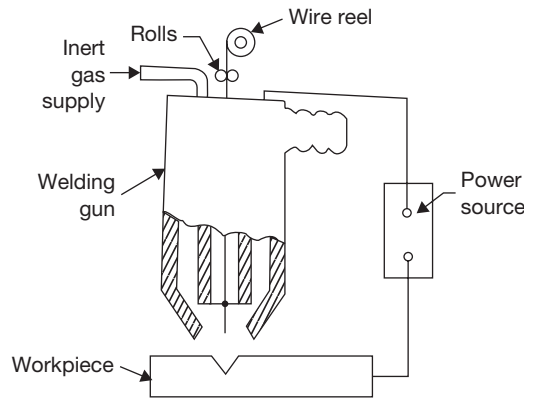
In MIG welding, a high current density is supplied to the electrode and workpiece. Carbon dioxide gas or any inert gas like helium or argon is supplied to protect the weld pool. The electrode used is consumable and is in the form of a wire. Automated feed of the wire is used as shown in Figure 20.33. The welding current is used in the range of 100-300 amp. In this welding process, the metal transfer rate is very high. Therefore, it is generally used for welding of thick plate. The metals, welded by MIG welding are alloy steel, stainless steel, copper, brass, aluminum, magnesium, nickel, lead, silver, tungsten, etc. The current used is direct current and voltage is constant-arc voltage (CAV). Electrode used as a positive pole and work as the negative pole.

### Advantages

- ▶ The rate of weld deposition is very high.
- ▶ The quality of the weld is good due to the transfer of molten metal under the protection of inert gases.
- ▶ No frequent change of electrode is required.
- ▶ No flux is required; therefore no slug forms over the weld. This makes the process cleaner.
- ▶ It is a versatile process and can be used on both light and heavy gauge structural plates.

### Limitations

- ▶ The cost of equipment and the consumable wire is much higher as compared to shielded arc welding.



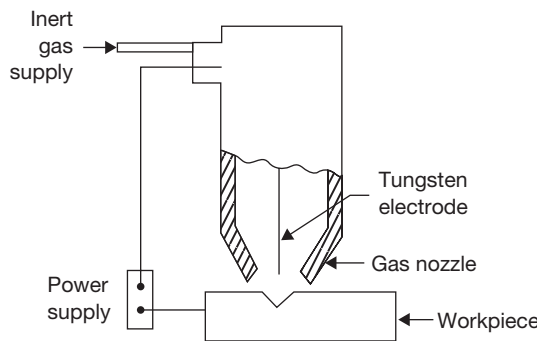
**FIGURE 20.33**

Metal Inert Gas Arc Welding

### 20.11.4 Tungsten Inert Gas Arc Welding (TIG)/Gas Tungsten Arc Welding (GTAW)

In this welding process, a non-consumable electrode of tungsten is used as shown in Figure 20.34. The filler material is supplied externally if it is required. The tungsten electrode is connected at negative pole of the power supply and work at positive pole of the power supply. Inert gas like argon or helium is supplied through a gas nozzle to protect the molten metal pool. The current used in TIG welding is both A.C. and D.C. Gases used as shielding gases are nitrogen for stainless steel and argon for aluminum and magnesium. Reactivity of nitrogen is very high with aluminum and magnesium at an elevated temperature. When an explosion problem does not exist, hydrogen gas may be used.

The TIG welding may be used as fusion welding of aluminum, magnesium, stainless steel, alloy steel, Monel, Inconel, brass, bronze, tungsten, silver, molybdenum, etc. To avoid the melting of the electrodes, for larger current and better thermionic emission thorium or zirconium is added to the tungsten electrode.



**FIGURE 20.34**

Tungsten Inert Gas Arc Welding

### Advantages

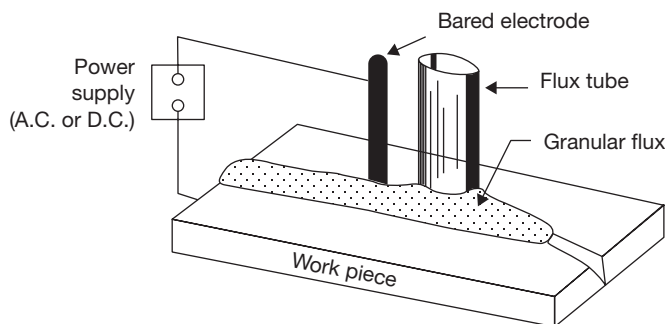
- ▶ Since no flux is used, no special cleaning or slag removal is required. Most of the fluxes are corrosive in nature which prevents their use in food, drink and some chemical industries.
- ▶ It produces smooth and sound welds with fewer spatters.
- ▶ It can be easily automated.
- ▶ Welding can be done in all positions.

### Limitations

- ▶ The cost of inert gases is high.
- ▶ Due to slow speed, it cannot be used for thick metal plates.

### 20.11.5 Submerged Arc Welding (SAW)

This welding process is very similar to MIG welding except that a blanket of granular, fusible flux shields the metal arc during the welding operation instead of inert gas. A bare electrode is fed through the welding head into the flux as shown in Figure 20.35. The arc is started either by striking the electrode on the work beneath the flux or initially by placing some conductive medium like steel wool beneath the electrode. The intense heat melts the flux and produces a pool of molten metal in the joint. The slag floats on the top of the molten metal, forming a blanket, which eliminates spatter loss and protects the welded joint from atmospheric contamination or oxidation. This process uses A.C. or D.C., high current 300 to 4000 amperes. It is not suitable for the plate of thickness less than 8 mm, and for vertical or overhead welding. The metals can be welded by this process are carbon steel, alloy steel, stainless steel, nickel, copper, etc. It is not suitable for aluminum and magnesium alloys.



**FIGURE 20.35**

Submerged Arc Welding

### *Advantages*

- ▶ Since the arc is completely hidden under a blanket of flux, there is no flash, spatter or smoke.
- ▶ Very high current can be used. In conventional welding, where the arc is exposed, current above 300A must be used with care due to the high intensity of infrared and ultraviolet light rays. No such problems arise in this process due to arc covered with flux.
- ▶ It gives high deposition rate and deep penetration due to high current used in the process.
- ▶ High welding speed is possible.
- ▶ The quality of the weld is very good because of high cleanliness of the process.

### *Limitations*

- ▶ It is largely limited to flat position welding.
- ▶ This process is not suitable for high-carbon steels, tool steels, aluminum, magnesium, titanium lead or zinc because of numerous factors including unavailability of suitable fluxes, reactivity at high-temperature, and low sublimation temperature.
- ▶ It is normally not suitable for welding of the metal plate of thickness less than 8 mm. because of a chance of burning.
- ▶ Possible contamination of the flux by moisture can lead to porosity in the weld.
- ▶ Other limitations include extensive flux handling, removal of a large volume of slag.
- ▶ There is large heat affected zone.

## 20.11.6 Electroslag Welding

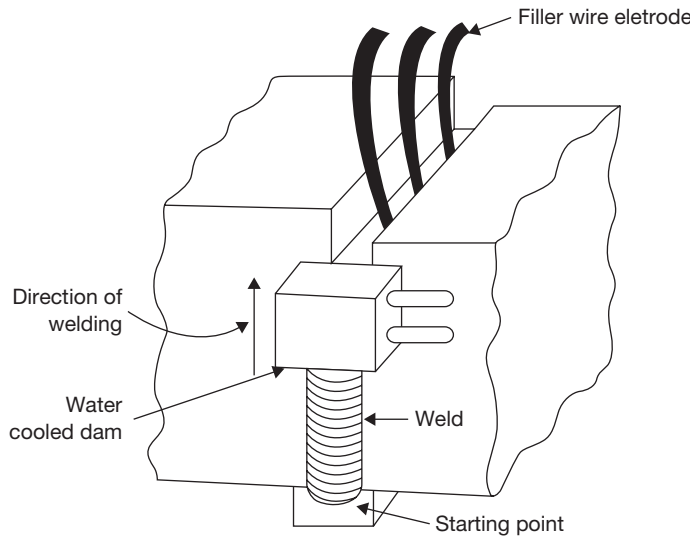
Electroslag welding is used for welding of thick metal plates. Two plates are kept vertical at a distance of 2–3 cm. The filler wires and flux are kept in this gap. Here, the filler wires are used as the electrodes. The current supplied is A.C. Initially, an arc is created which melts the flux, and thereafter the molten flux short circuits; arc and heat are generated due to resistance heating of slag, and thus workpiece and electrodes are melted. The molten metal piece and slag are retained by a water cooled dam as shown in Figure 20.36. Since the weld pool formed is large and the welding speed is slow, the cooling rate is quite low. After cooling, heat treatment is required to restore the strength due to large grain size.

### *Advantages*

- ▶ This is most suitable welding process for thick plates ranges from 50 mm to 900 mm.
- ▶ Weld is completed in single pass only. Thus weld quality is improved.
- ▶ It gives high deposition rates.
- ▶ Flux consumption is lesser in comparison to submerged arc welding.

### *Limitations*

- ▶ Welding is restricted to only vertical positions.
- ▶ This is suitable for welding of only thick metal plates.

**FIGURE 20.36**

Electroslag Welding

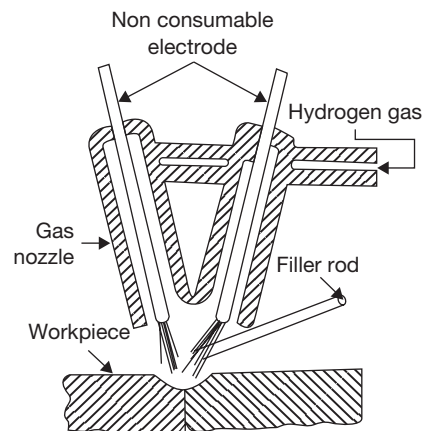
- ▶ Solidification rate is required to be controlled for better quality of the weld.
- ▶ After welding heat treatment is requires.

### 20.11.7 Atomic Hydrogen Welding

In this welding, the arc is created between two non-consumable electrodes (as shown in Figure 20.37) by supplying A.C. current. When hydrogen gas is passed through the arc, the heat of arc is absorbed by hydrogen molecules and dissociate into hydrogen atoms. When hydrogen atoms reach cold work surface recombines and form hydrogen molecules by releasing a large amount of heat. Thus, work surface melts by the heat of hydrogen recombination. If the filler material is required a filler rod is fed into the arc. The temperature is of the order of 3000°C.

#### Advantages

- ▶ It gives high heat concentration as hydrogen gas can be passed through the narrow slit.

**FIGURE 20.37**

Atomic Hydrogen Welding

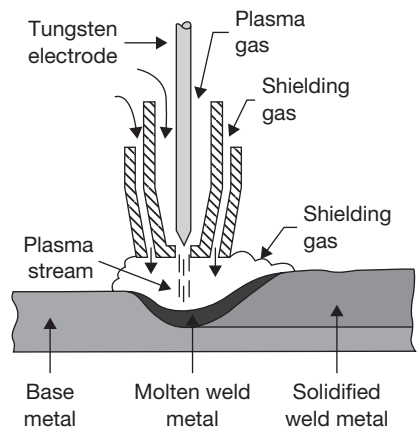
- ▶ There no need to provide additional shielding gas as hydrogen also shields the molten metal pool.
- ▶ It is used successfully for many alloys which are difficult to weld by other processes due to the need of high heat generation.

### Limitations

- ▶ It is outdated and rarely used in industry.
- ▶ There is a hydrogen induced cracking problem.

## 20.11.8 Plasma Arc Welding

A highly ionized gas is known as plasma. In a plasma arc welding, the arc is created between a non-consumable tungsten electrode and workpiece. A water-cooled copper nozzle surrounds tungsten electrode, which is used as a cathode as shown in Figure 20.38. A gas (inert gas) like argon is supplied surrounding the tungsten electrode. The gas is forced through the orifice, where it is heated to a high-temperature through resistance heating and forms a plasma. Plasma is an ionized hot gas. It conducts electricity. The temperature of plasma gas may as high as 33000°C, which is sufficient to melt any workpiece. The copper nozzle is water-cooled. A supplementary shielding gas may be used if required. The heat is transferred through the plasma to workpiece.



**FIGURE 20.38**

Plasma Arc Welding

There are two methods of plasma arc welding—transferred type and non-transferred type. In transferred type, tungsten electrode acts as cathode and workpiece as an anode. The arc is transferred from cathode to anode. In non-transferred type, tungsten electrode acts as a cathode but copper nozzle acts as an anode and arc is not transferred to the workpiece. The heat is carried to the workpiece by plasma gas. This method creates high noise during welding (100 db). But it is a fast method and suitable for a number of metals.

### Advantages

- ▶ High heat concentration results in high welding speed.
- ▶ It has improved arc stability.
- ▶ It minimizes thermal distortion.
- ▶ It has a lower width to depth ratio of the weld.
- ▶ The focused heat of plasma results in the narrower weld, less heat affected zone, and deeper penetration.



### *Limitations*

- ▶ The equipment is very expensive, approximately five times more than TIG equipment.
- ▶ Long arc length results in excessive production of ultraviolet and infrared radiations which can harm the skin.
- ▶ Gas consumption is high.
- ▶ Noise level is very high approximately 100 db which is more than the permissible limit of 80 db.
- ▶ Nozzle needs frequent replacement.

## **20.12 ► RESISTANCE WELDING**

In a resistance welding, heat is generated by passing an electric current through the high resistance. The amount of heat generated depends on the value of current and resistance as shown in the formula.

$$H = I^2 \cdot R \cdot t \text{ Joule.}$$

where I = Current in ampere, R = Resistance in ohm, t = Time in second.

When the electric current is passed through the welding members, they offer maximum resistance at the interface in comparison to other parts of the member. Hence largest heat is generated at the interface. When the proper temperature is reached, the pressure is applied to complete the weld. Because of application of pressure, the process requires lower temperature as compared to oxy-fuel gas or arc welding as the metal has to reach the softened state, not in the molten state.

There are six types of resistance welding:

1. Spot welding.
2. Seam welding.
3. Projection welding.
4. Flash welding.
5. Percussion welding.
6. Butt-welding.

### *Advantages*

- ▶ This is a fast process and suitable for mass production.
- ▶ No fluxes or filler materials are required.
- ▶ Less skilled operators may be employed.
- ▶ Practically all conductive materials can be welded by this method.

### *Limitations*

- ▶ Few metals like tin, zinc, and lead are difficult to weld by this method.
- ▶ Control of pressure and current during the process is critical.
- ▶ Equipment cost is high.

### 20.12.1 Resistance Spot Welding

It is the simplest form of resistance welding. In this process, a pair of water-cooled copper electrodes is used. Two overlapping metal plates are held between these electrodes jaws as shown in Figure 20.39.

The pressure is applied to a very small area, which is known as spot. The resistance at the inner face is very high so applying low voltage and high current melts the inner surface and after solidification makes a spot joint. The current used may be 3000 to 40,000 A; this depends on the melting point of the material to be welded. The voltage applied may be 20–90 V. The diameter of spot welds ( $d$ ).

$$d = 1.2 t + 4 \text{ mm, for thickness, } t < 3 \text{ mm.}$$

$$= 1.5 t + 5 \text{ mm, for thickness, } t > 3 \text{ mm.}$$

Spacing of spot weld should be 3 times of the diameter of the spot weld. The complete weld cycle is divided into four parts.

1. Squeeze time.
2. Weld time.
3. Hold time.
4. Off time.

**Squeeze Time:** During this time, workpieces are under pressure and the electrodes are in contact with them. The squeeze time is used to bring two pieces together in contact just before the current flow. The pressure gradually increases from zero to certain value during this time interval.

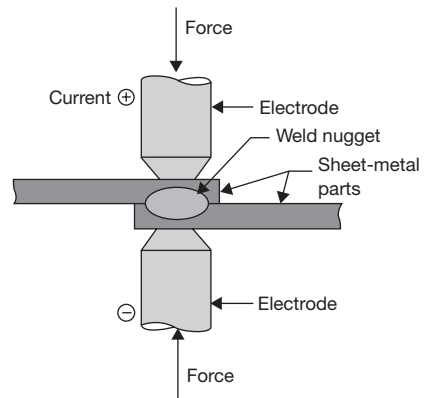
**Weld Time:** During this period the current is switched on and the temperature at the interface starts rising and attains welding temperature to melt the metal at the interface. The pressure should then be increased considerably just as the proper welding heat is attained. Pressure is the most important variable in resistance welding. Pressure is inversely proportional to resistance. Pressure is high if resistance is low otherwise pressure is low if resistance is high.

**Hold Time:** During this time weld starts cooling and the pressure is further increased.

**Off Time:** During this period pressure is released and the workpiece is removed from the spot.

#### Advantages

- ▶ Similar and dissimilar metals can be welded very easily.
- ▶ The time involved in spot welding is very less.



**FIGURE 20.39**

Resistance Spot Welding

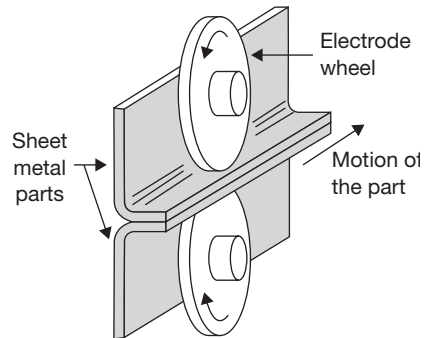
- ▶ Sheets of different thickness can be joined easily.
- ▶ It can be used for the large production run with the help of multiple spot welding machines.

### Limitations

- ▶ Silver and copper are especially difficult to weld because of their high thermal conductivity.
- ▶ Spot welding is limited to overlap welding only.

## 20.12.2 Resistance Seam Welding

Resistance seam welding is series of continuous spot welding. In this welding process, the electrodes used as copper rollers in the place of cylindrical copper jaws in spot welding as shown in Figure 20.40. The diameter of the rollers may be from 40 mm to 350 mm and welding current from 2000 to 5000 amp. Welding speed ranges from 0.5 to 3.5 m/min. The pressure is applied by the roller on the workpiece. Rest of the process is same as the in the spot welding.



**FIGURE 20.40**

Resistance Seam Welding

### Advantages

- ▶ The power requirement is very low due to the use of low voltage power requirement.
- ▶ The heat affected zone is very small, hence thermal distortion is negligible.
- ▶ Similar and dissimilar metals can be welded very easily.
- ▶ Welding speed is high which makes it suitable for a large-scale production.

### Limitation

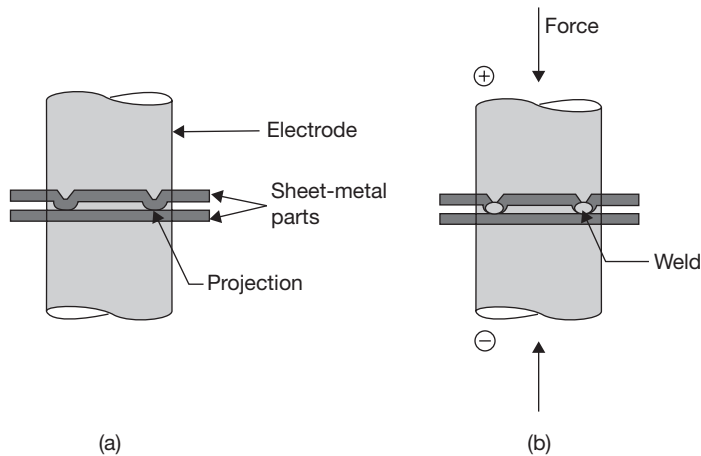
- ▶ This method is suitable for overlap welding only.

## 20.12.3 Resistance Projection Welding

Projection welding is a variation of spot welding. Small projections are embossed at the plate where welds are desired as shown in Figure 20.41 (a). The workpieces are then placed between large-area electrodes and current is switched on. High temperatures are generated at the projections. During the process, the projections collapse, as shown in Figure 20.41(b) owing to heat and pressure, and workpieces are brought in close contact. The shape of the projection may be circular oval depending on the design.

### Advantages

- ▶ This is a faster process as a number of welds are made simultaneously.
- ▶ A small amount of current is required due to large density of current at the projection only.

**FIGURE 20.41**

Resistance Projection Welding

- ▶ The pressure required on the electrode is low.
- ▶ Thermal shrinkage and distortion are less.

### *Limitation*

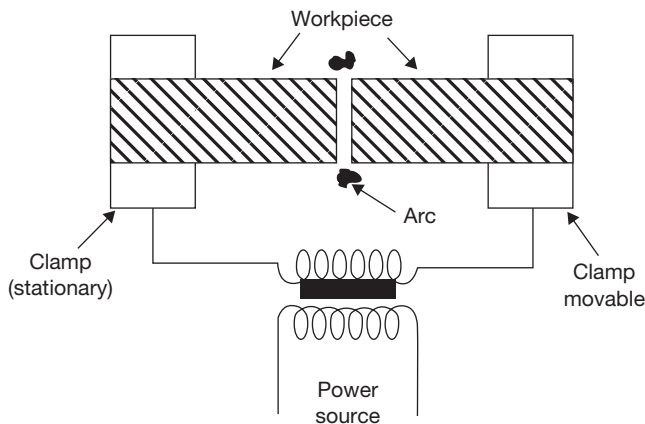
- ▶ Correct application of pressure and current are very important.

### 20.12.4 Flash Welding

Flash welding is used to make an end-to-end joint of two thick metal pieces as shown in Figure 20.42. In this method, current is switched on and then the ends to be welded are brought closer slowly to make contact. Thus heat is localized at the ends and reaches the welding temperature. The ends, after they have contact with each other are then forced against each other by applying mechanical pressure which forces the molten metal and slag to be squeezed out in the form of sparks enabling the pure metal to form the joint and disallowing the heat to spread back.

### *Advantages*

- ▶ It consumes less current.
- ▶ Large area (end-to-end) can be welded.
- ▶ Edge preparation is not required.
- ▶ The excellent weld can be made at a high production rate.
- ▶ The joint is stronger.

**FIGURE 20.42**

Flash Welding

### *Disadvantages*

- ▶ Metals like lead, zinc, tin, copper and their alloys are not welded by this method.
- ▶ The equipment is expensive.

### 20.12.5 Percussion Welding

In percussion welding, the welding heat is obtained by an arc produced by a rapid discharge of stored electrical energy in a capacitor. The parts to be joined are placed in a position similar to flash welding. The intense heat of arc melts the parts. The heated parts then pressed together to complete the weld. This process is very fast on account of rapid discharge of power to the arc. The arc durations are only 1 to 10 m/sec, after which it is extinguished by the percussion blow of the two parts coming together. The use of this process is limited to very thin wires of diameters from 0.05 mm to 0.38 mm. It can also be used for joining wires of dissimilar metals such as copper to nichrome and copper to stainless steel.

### *Advantages*

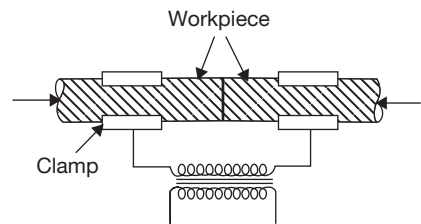
- ▶ There is no thermal distortion due to small heat affected zone.
- ▶ The metal of different thermal conductivity can be welded easily as heat is concentrated at the two surfaces only.
- ▶ No upsetting occurs at the joint.
- ▶ Heat treated part may be welded without being subjected to annealing.

### *Disadvantages*

- ▶ Only small areas can be welded.
- ▶ The part should have a regular section.

### 20.12.6 Resistance Butt Welding

In a resistance butt welding process, the workpieces which are to be joined are placed end to end between two clamps and required pressure is applied (Figure 20.43). The high resistance at the joint generates heat on supplying high current and causes fusion to take place at the interface. The pressure applied ranges from 15 to 55 MP. The ends of two pieces are slightly upset and hence term upset welding. In this process cross section areas of workpieces used are same. The current density used is 2000 to 5000 A / inch<sup>2</sup>.



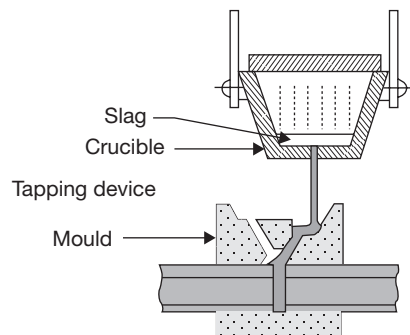
**FIGURE 20.43**

Resistance Butt Welding

### 20.13 ► THERMIT WELDING

Thermit welding is similar to casting. A mixture of powdered aluminum and iron oxide is placed inside a vessel. The mixture is ignited by heating to about 1550°C with the help of barium oxide powder. A chemical reaction takes place in a vessel as shown in Figure 20.44.

Due to the chemical action, a bright white heat is produced and reaction leads to molten iron. The molten iron is tapped from the vessel and made to run in the cavity of the joint. The temperature attained is about 3000°C.



**FIGURE 20.44**

Thermit Welding

#### *Advantages*

- It produces high-quality welds because the metal solidifies from the inside towards the outside, and all air is executed from around the molds.
- There is no limit to the size of welds that can be made by thermit welding.

#### *Disadvantages*

- It is an extremely old process and has been replaced to a large degree by an alternative method such as electroslag welding.

### 20.14 ► WELDING ALLIED PROCESSES

#### 20.14.1 Soldering

Soldering is a process of joining two metals by applying low melting point metal or alloy in the gap between the joining parts. The metal or alloy used for filling or joining is known as solder. The melting point of solder is less than 450°C. In soldering joining process, the

heat is supplied to the joint by soldering iron. The soldering iron may be heated electrically or by other means. The function of soldering iron is to heat the joint. The flat face of the soldering iron is held directly against the joint assembly so that the heat is transferred effectively to the parts being soldered. In soldering joining process, the heat is supplied to the joint by soldering iron. The soldering iron may be heated electrically or by other means. The function of soldering iron is to heat the joint. The flat face of the soldering iron is held directly against the joint assembly so that the heat is transferred effectively to the parts being soldered.

Most of the solders used in soldering joining process are made of lead and tin alloys. Some solders also contain small amounts of cadmium and antimony. The amount of percentage composition of tin and lead determines the physical and chemical properties of joints made with solder. Solders are divided into two categories.

- ▶ Soft solder is an alloy of tin and lead.
- ▶ Hard solder is alloy of copper and zinc.
- ▶ *Flux Used:* Chlorides fluxes (Zinc Chloride, Ammonium Chloride, and Zinc ammonium chloride).
- ▶ This joining process forms a weak joint.

### 20.14.2 Brazing

Brazing is a hard soldering process, but in this process, metal pieces are heated which are to be joined in this place of the bit as in soldering. In a brazing, spelter is used it is a mixture of copper, zinc and tin. It is stronger in comparison to soldering joint. Brazing may be defined as a joining process that takes place above 450°C but below the melting point of the base metals. Most of the brazing operations are done at temperatures ranging from 600 to 800°C. Since, brazing is done at high-temperature, brazing is useful for joining thick metal parts for making relatively stronger joints. Both similar and dissimilar parts can be joined. The success of brazing operation depends upon that a fact that a molten metal of low surface tension will flow easily and evenly over the surface of a properly heated and chemically clean base metal, just as water flows over a clean glass plate.

During brazing, the base metal of two pieces to be joined is not melted. An important requirement is that, similar to soldering, the filler metal must be wet the base metal surfaces to which it is applied. Some diffusion or alloying of the filler material with the base metal takes place even through the base metal does not reach its solidus temperature. The surfaces to be joined must be made chemically clean before brazing operation is started. However, the fluxes are applied to remove oxides from the surfaces. Borax is the most commonly used flux during the brazing process. It will dissolve the oxides of most of the common metals.

### *Advantages of Soldering and Brazing:*

- ▶ Low operation temperature.
- ▶ Joints can be made permanently or temporarily.
- ▶ Metals of dissimilar can be joined.
- ▶ High speed of joining.
- ▶ Less chance of damaging parts.
- ▶ Parts of varying thickness can be joined.
- ▶ Easy re-alignment.

### **20.14.3 Braze Welding**

In braze welding, the molten filler metal is not distributed at the joint by capillary action as it happens in brazing or soldering but it is deposited at the point where the weld is required to be made as in the case of gas welding. The braze welding process is a variant of the MIG/MAG welding process, where the majority of the process essential variables are identical to conventional MIG/MAG welding processes. However, in the braze welding process, the melting point of the filler wires is significantly lower than the melting point of the parent material. During the arc welding process, the filler wire melts at temperatures typically over 1600°C, whereas for brazing the wire melts at less than 1000°C.

As in the standard MIG/MAG welding process, a continuously fed wire electrode is melted by an arc formed between the electrode and the workpiece, but no significant melting or fusion of the parent metal occurs because of the lower temperature. The molten metal flows into the gap between the parts to be joined and solidifies after wetting either across or between the surfaces via capillary action to form the solid joint.

### *Advantages*

- ▶ The requirement of less preheating and permitting greater welding speed, a shorter cooling-off period, and is less likely to crack metals.
- ▶ No splash or weld spatter.
- ▶ A little or no finishing requirement of the completed joints.
- ▶ No requirement of as much skill as the technique required for fusion welding.

### *Disadvantages*

- ▶ If the joint is to be exposed to corrosive media, the filler metal must have the required corrosion-resistant characteristics.
- ▶ All brazing alloys lose strength at elevated temperatures.
- ▶ If the joint is to be painted, all traces of the flux must be removed.



## 20.15 ► WELDING DEFECTS

A number of defects can occur during the welding processes, some of them are shown in Figure 20.45. There are many other defects which are discussed in following paragraphs.

**Cracks:** Cracks occur in the welded joint due to improper welding and solidification of different metals. Cracks may be of following types.

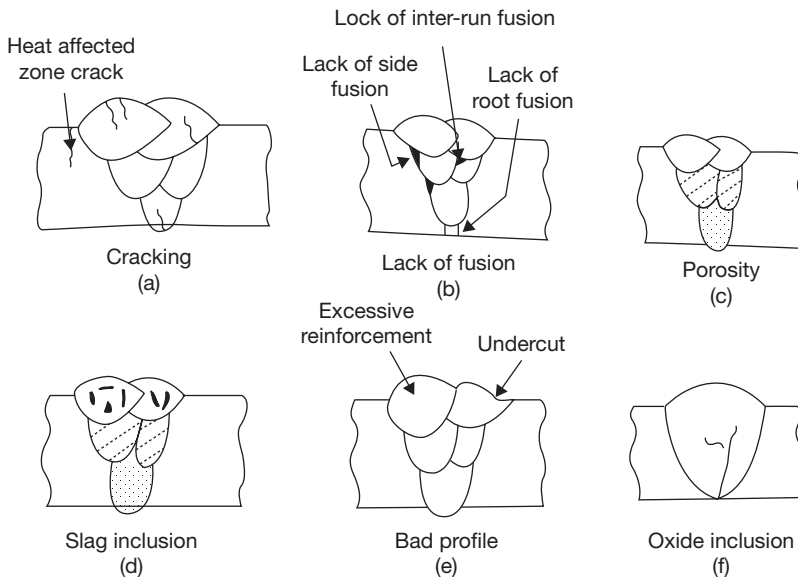
**Micro Cracks:** Very small Cracks, which can be seen with the help of microscope only.

**Macrocracks:** These cracks can be seen by naked eye.

**Fissures:** These cracks are wider, which occur at the surface of the metal.

There are different types of cracks. Cracks occurred in the base metal is known as cold crack because it occurs at low-temperature due to improper welding, high cooling rate, wrong filler material, high carbon and phosphorous in parent metal. Crack occurred in the hot metal zone or weld metal zone is known as hot cracks and it occurs due to improper solidification, clamping, etc.

**Lack of Fusion:** Wrong weld parameters, such as poor weld design, feed rate, welding speed, current, and voltage, lead the problem of fusion and penetration. A proper arc length, good weld design may prevent the problem of poor fusion and improper penetration.



**FIGURE 20.45**

Welding Defects

**Porosity:** Porosities are voids, holes or cavities of usually spherical shapes. It is caused by gas entrapped in weld metal during solidification, and chemical reactions during welding contaminates such as dirt, oil, grease, rust, paint, etc. Blowholes are voids of large size. Porosity and blowholes are scattered throughout the cross-section of a weld randomly. Small porosities appeared on the surface are known as pinholes. Pinholes are smaller in size. To reduce the porosity there should be proper shielding of the molten metal pool, proper cleaning, i.e., free from oil, grease, paints, etc., to avoid absorption of gases like  $O_2$ ,  $N_2$ ,  $H_2$ .

**Slag Inclusion:** Slag inclusion in the form of oxides, sulphur, and flux in the weld causes poor strength and leads to corrosion in the metal. It occurs due to inadequate cleaning of the welding areas.

**Shrinkage Cavity:** It occurs in the welding of thicker parts where a large amount of filler metal is required. The molten metal shrinks during solidification and forms a cavity on the surface, which is known as shrinkage cavity.

**Undercutting:** Undercutting is a form of a groove on the welding surface. It occurs due to high current and high arc voltage. Proper controlling of current and voltage can prevent it.

**Spatter:** Spatters are small bead thrown in all directions during welding. It occurs due to very large current and wrong electrode selection.

**Distortion:** Distortion is a result of the improper rate of heating and cooling in the weld zone or adjacent metal leading to the generation of stresses. Proper clamping and smaller diameter electrode may reduce the problem.

## RECAP ZONE .....



### Points to Remember

- The temperature of a body shows a degree of hotness with respect to reference body.
- The **casting process** can be defined as a primary shaping process in which a molten metal is poured into a mould cavity and allowed to solidify for a predetermined time so as to take the shape of the mold, after complete solidification, it is taken out from the mold.
- The product of casting is also known as casting and the place where casting work is done is known as “**foundry shop**”.
- The green sand is a mixture of green sand, binders, and water.
- **Pattern** is a replica of the product, which is to be manufactured through casting. It is used to make a mold cavity of required shape and size.
- Various types of pattern materials such as wood, aluminium, steel, plastic, cast iron are used in sand casting.
- The extra dimensions or extra materials provided for the pattern are known as **allowances**.

- Mold making is a process of creating a replica of casting with the help of patterns and moulding sand.
- The cavity, produced in the sand body, facilitates the molten metal to solidify and to take the shape of the cavity.
- **Risers** are provided in the mold to feed molten metal into the cavity to compensate the shrinkage.
- **Chills** are used to improve the directional solidification with faster heat conduction by metallic chills; solidification is initiated and accelerated at desired locations.
- Sometime, it is impossible to use core print to support the core. In this case, a metallic support is used which is known as chaplet.
- **Chaplet** is made of same material as the material of casting. It gets fused with molten metal.
- **Core** is a sand body specially prepared in a core box and it is used to form a cavity/hole/recess or projection in a casting for different purposes.
- **Casting defects** are unwanted feature or irregularities in casting which make it of poor quality. These defects occur due to several reasons such as poor design of casting, excess moisture in mould, improper ramming of molding sand, misalignment of cope and drag, etc.
- **Welding** is a joining process that produces coalescence of materials by heating them to the welding temperature, with or without the application of pressure alone, and with or without the use of filler material.
- In **electric arc welding**, the heat required for melting the metal is generated by short-circuiting the electrodes.
- In **gas welding process**, various types of gases are burnt in combination with oxygen and the flame is applied at the edge of metal plates to be joined. The heat of combustion of the gas melts the metal; filler material may or may not be applied to fill the groove.
- In a **resistance welding**, heat is generated by passing an electric current through the high resistance.
- **Soldering** is a process of joining two metals by applying low melting point metal or alloy in the gap between the joining parts. The metal or alloy used for filling or joining is known as solder.
- **Brazing** is a hard soldering process, but in this process, metal pieces are heated which are to be joined in this place of the bit as in soldering.

## REVIEW ZONE .....



### Multiple-choice Questions

#### Casting

1. In sand molding, the middle part of box is called:
  - (a) Cope
  - (b) Drag
  - (c) Cheek
  - (d) Flask-middle
2. Core is used to:
  - (a) Make desired recess in casting
  - (b) Strengthen molding sand
  - (c) Support loose pieces
  - (d) Remove pattern easily
3. Shrinkage allowance is made up by:
  - (a) Adding to external and internal dimensions
  - (b) Subtracting from external and internal dimensions
  - (c) Subtracting from the external dimension and adding to the internal dimension
  - (d) Adding to external dimension and subtracting from the internal dimension.
4. Facing sand in foundry work comprises of:
  - (a) Silica and clay
  - (b) Clay and alumina
  - (c) Silica and alumina
  - (d) Clay and silica

5. The purpose of sprue is to:
  - (a) Feed the casting at a rate consistent with the rate of solidification
  - (b) Act as a reservoir for molten metal
  - (c) Help in feeding the casting until the solidification takes place
  - (d) Feed molten metal from pouring basin to the gate
6. The purpose of riser is:
  - (a) Feed the casting at a rate consistent with the rate of solidification
  - (b) Act as a reservoir for molten metal
  - (c) Help in feeding the casting until the solidification takes place
  - (d) Feed molten metal from pouring basin to the gate
7. Down sprue in casting is given a taper shape for:
  - (a) Easy flow of molten metal
  - (b) Easy withdrawal of casting
  - (c) Preventing aspiration of gases through the sprue
  - (d) Preventing bulging of sprue during pouring
8. Draft on pattern is provided for:
  - (a) The easy flow of molten metal
  - (b) Easy withdrawal of casting
  - (c) Preventing aspiration of gases through the sprue
  - (d) Preventing bulging of sprue during pouring
9. True centrifugal casting is used to:
  - (a) Ensure purity and density at extremities of a casting
  - (b) Cast symmetrical object
  - (c) Obtain high density and pure casting
  - (d) Use heavy cast iron mold to act as chill
10. Semi-centrifugal casting is used to:
  - (a) Ensure purity and density at extremities of a casting
  - (b) Cast symmetrical object
  - (c) Obtain high density and pure casting
  - (d) Use heavy cast iron mold to act as chill
11. Surfaces to be machined are marked on the pattern by:
  - (a) Black
  - (b) Yellow
  - (c) Red
  - (d) Blue
12. Centrifugal method of casting is used to:
  - (a) Ensure purity and density at extremities of a casting
  - (b) Cast symmetrical object
  - (c) Obtain high density and pure casting
  - (d) Use heavy cast iron mold to act as chill
13. Blind risers:
  - (a) Assist in feeding the metal into casting properly
  - (b) Help to trap slag or other lighter particles
  - (c) Supply the hottest metal when pouring is completed
  - (d) Do not exist
14. Shift is a casting defect which:
  - (a) Results in a mismatching of the top and bottom parts of the casting
  - (b) Is due to enlargement of the mold cavity by metal pressure
  - (c) Occurs near the gates as rough lumps on the surface of the casting
  - (d) Is due to the thin projection of metal not intended as a part of the casting
15. Swell is a casting defect which:
  - (a) Results in a mismatching of the top and bottom parts of the casting
  - (b) Is due to enlargement of the mold cavity by metal pressure
  - (c) Occurs near the gates as rough lumps on the surface of the casting
  - (d) Is due to the thin projection of metal not intended as a part of the casting
16. Sand wash is a casting defect which:
  - (a) Results in a mismatching of the top and bottom parts of the casting
  - (b) Is due to enlargement of the mold cavity by metal pressure
  - (c) Occurs near the gates as rough lumps on the surface of the casting
  - (d) Is due to the thin projection of metal not intended as a part of the casting
17. Fin is a casting defect which:
  - (a) Results in a mismatching of the top and bottom parts of the casting
  - (b) Is due to enlargement of the mold cavity by metal pressure
  - (c) Occurs near the gates as rough lumps on the surface of the casting
  - (d) Is due to the thin projection of metal not intended as a part of the casting
18. Slag inclusion in casting is a:
  - (a) Surface defect
  - (b) Internal defect
  - (c) Superficial defect
  - (d) None of these
19. Felting of casting is done to:
  - (a) Produced uniformly cooled casting
  - (b) Remove to extra metals from casting

- (c) Smoothen surface
- (d) All of the above

20. Casting defect developed due to inadequate venting is:
- (a) Inclusion
  - (b) Blow holes
  - (c) Cold shuts
  - (d) None of these

### Welding

21. In gas welding, maximum temperature occurs at:
- (a) Inner cone
  - (b) Outer cone
  - (c) Next to the inner cone
  - (d) Tip of the flame
22. In oxyacetylene as welding, flame temperature used is:
- (a) 1200°C
  - (b) 1800°C
  - (c) 2400°C
  - (d) 3200°C
23. Gray cast iron is generally welded by:
- (a) Gas welding
  - (b) Arc welding
  - (c) TIG welding
  - (d) MIG welding
24. In thermit welding, aluminum and iron oxides are mixed in the proportion of:
- (a) 1:1
  - (b) 1:2
  - (c) 1:3
  - (d) 3:1
25. For proper mixing of oxygen and pressure regulation of acetylene and oxygen in oxyacetylene welding, the device used is:
- (a) Welding torch
  - (b) Cylinder
  - (c) Hose pipe
  - (d) None of the above
26. In arc welding, penetration is deepest for:
- (a) DCRP
  - (b) DCSP
  - (c) A.C.
  - (d) None of these
27. The hard filler material used in brazing is:
- (a) Solder
  - (b) Flux
  - (c) Spelter
  - (d) Electrode
28. Solder is essentially a:
- (a) Tin silver base
  - (b) Tin lead base
  - (c) Silver lead base
  - (d) Bismuth lead base
29. Oxygen to acetylene ratio in case of neutral flame:
- (a) 1:1
  - (b) 1.2:1
  - (c) 0.8:1
  - (d) 2:1
30. Oxygen to acetylene ratio in case of oxidizing flame:
- (a) 1:1
  - (b) 1.2:1
  - (c) 1.5:1
  - (d) 2:1
31. Oxygen to acetylene ratio in case of carburizing flame:
- (a) 1:1
  - (b) 1.2:1
  - (c) 0.9:1
  - (d) 2:1
32. Main advantage of MIG welding over TIG welding is that:
- (a) Former can be used to weld hard metals
  - (b) Former permits use of large currents thereby allowing higher deposition
  - (c) Welding rate is very fast
  - (d) Welding is completely automatic
33. Flux used for brazing cast iron is:
- (a) A mixture of boric acid, borax and a wetting agent
  - (b) A mixture of boric acid, borax of fluoride with a wetting agent
  - (c) Chlorides and fluorides mixed with water
  - (d) None of the above
34. Soldering iron is made of wedge shape in order to:
- (a) Apply high-pressure at the edge
  - (b) Retain heat
  - (c) Retain solder
  - (d) Facilitate molecular attraction
35. Carburizing flame is used to weld metal like:
- (a) Steel
  - (b) Copper and Brass
  - (c) Aluminum, stainless steel, Zinc die casting, Nickel, Monel metal
  - (d) None of the above

## Fill in the Blanks

36. Pipes of large length and diameters are made by \_\_\_\_\_.
37. Felting in casting is used to \_\_\_\_\_.
38. The process of removal of sprue and riser from casting is known as \_\_\_\_\_.
39. Chills are metal inserts that are placed at appropriate location in the mold to help \_\_\_\_\_.
40. Core print is an added projection on the pattern and forms a seat to support and locate \_\_\_\_\_.
41. The maximum quantity moisture content in the molding sand can be up to \_\_\_\_\_.
42. Acetylene gas is produced from \_\_\_\_\_ by reacting with \_\_\_\_\_.
43. Thermit welding employs \_\_\_\_\_ for generating high heat.
44. In submerged arc welding, the metal arc is shielded by \_\_\_\_\_.
45. The porosity in welded metal is caused by \_\_\_\_\_.
46. In straight polarity, work piece is connected to \_\_\_\_\_.
47. In reverse polarity, work piece is connected to \_\_\_\_\_.
48. In D.C. arc welding, maximum heat is generated at \_\_\_\_\_.
49. The main function of the flux is to form \_\_\_\_\_ and protect the \_\_\_\_\_.
50. In arc welding, the electric arc is produced between the work and electrode by \_\_\_\_\_.

## Answers

- |                                |         |                                   |         |                         |         |
|--------------------------------|---------|-----------------------------------|---------|-------------------------|---------|
| 1. (c)                         | 2. (a)  | 3. (d)                            | 4. (a)  | 5. (d)                  | 6. (c)  |
| 7. (c)                         | 8. (b)  | 9. (b)                            | 10. (a) | 11. (c)                 | 12. (a) |
| 13. (c)                        | 14. (a) | 15. (b)                           | 16. (c) | 17. (d)                 | 18. (a) |
| 19. (b)                        | 20. (b) | 21. (c)                           | 22. (c) | 23. (a)                 | 24. (c) |
| 25. (a)                        | 26. (b) | 27. (c)                           | 28. (b) | 29. (b)                 | 30. (c) |
| 31. (c)                        | 32. (b) | 33. (b)                           | 34. (b) | 35. (c)                 |         |
| 36. centrifugal casting        |         | 37. to remove the external metals |         | 38. flogging            |         |
| 39. directional solidification |         | 40. core                          |         | 41. 8%                  |         |
| 42. calcium carbide and water  |         | 43. exothermic reaction           |         | 44. flux                |         |
| 45. defective work materials   |         | 46. +ve terminal                  |         | 47. -ve terminal        |         |
| 48. +ve terminal               |         | 49. slag, molten metal            |         | 50. contact resistance. |         |

## Theory Questions

### Casting

1. What is casting? How it differs from other primary shaping processes?
2. Enumerate and explain various allowances provided for pattern making.
3. Explain the application of various hand tools used in casting with neat sketch.
4. What are the various types of patterns? Explain them with their uses.
5. What are the required properties of molding sands? Classify the molding sand.
6. Explain the various types of molding sands and their uses.
7. Explain the advantages and disadvantages of sand casting.
8. Justify the statement that casting is most versatile forms of a mechanical process for producing components.
9. Briefly, explain hot chamber and cold chamber die casting.
10. What are the advantages of special casting techniques?
11. What purpose is served by risers in sand casting? Why they are not provided in die casting.
12. What are the advantages and disadvantages of die casting?
13. What is centrifugal casting? For what type of jobs would you recommend this casting process? Explain the process with the help of a neat sketch.
14. What are the casting defects? Explain the causes and remedies for these defects.
15. Explain the various cleaning process of castings.

### Welding

16. Describe the working principle of arc welding. Explain the shielded arc welding. How does it save the weldment from oxidation and absorption of nitrogen? What precautions need to be observed in arc welding?
17. Describe the basic fusion welding process. Explain the process details of electroslag welding.
18. What is the role of flux in Welding? Explain in detail.
19. What for Thermit welding is used.
20. Differentiate between neutral and oxidizing flame.
21. Compare the merits and demerits of using A.C. and D.C. set for arc welding.
22. What do you mean by arc blow problem? How can it be minimized?
23. Explain the soldering and brazing process.
24. What is gas welding? Explain with a neat sketch of welding torch and various flames.
25. What are the welding defects? Explain the causes and remedies.
- \*26. Explain briefly about soldering.
- \*27. Explain the principle of arc welding with a figure.
- \*28. Name the three types of oxy-acetylene flame. Explain the application of each of them.
- \*29. Differentiate between welding and brazing.
- \*30. Explain electric arc welding and oxy-acetylene welding with neat sketch.
- \*31. Briefly discuss the three types of flames used in gas welding and mention their applications.

\* indicates that similar questions have appeared in various university examinations.

# Mechanical Working of Metals, Sheet Metal Work, Powder Metallurgy, and Smithy

## Learning Objectives

*By the end of this chapter, the student will be able:*

- To differentiate hot working and cold working
- To describe the various mechanical forming processes
- To demonstrate the various tools used in sheet metal operations
- To describe the sheet metal processes
- To demonstrate the powder metallurgy processes
- To describe the various processes and tools used in Smithy

## MECHANICAL WORKING PROCESS

### 21.1 ► INTRODUCTION

Mechanical working is a process of shaping of metals by plastic deformation. When a metal is subjected to an external force beyond yield strength but less than the fracture strength of the metal, metal is deformed by slip or twin formation. There are two types of mechanical working process:

- (a) Cold working.
- (b) Hot working.

When metal is deformed between room temperature and recrystallization temperature, it is called cold working. This process is suitable for highly ductile metal. Recrystallization temperature is the temperature at which the crystal structure of the



metal starts to change. For low ductility, hot working is used. When metal is deformed between recrystallization temperature and a melting point of the metal, it is called hot working. In this process, the crystal structure of the metal is not deformed or distorted but it is rearranged.

### Comparison between Cold Working and Hot Working

Cold working	Hot working
<p><b>Advantages:</b></p> <ul style="list-style-type: none"> <li>(a) No oxidation or scaling on work surface.</li> <li>(b) Surface defects are removed.</li> <li>(c) Good surface finish.</li> <li>(d) High dimensional accuracy.</li> <li>(e) Heavy work hardening occurs and so the inherent strength of the material is permanently increased.</li> </ul> <p><b>Disadvantages:</b></p> <ul style="list-style-type: none"> <li>(a) A Large force is required for deformation therefore high capacity machine is used.</li> <li>(b) Several stages of deformation with interstage annealing is required.</li> <li>(c) The complexity of shapes that can be readily produced is limited.</li> <li>(d) Secondary stress relieving heat treatment is required.</li> <li>(e) Only ductile materials are cold worked.</li> </ul>	<p><b>Advantages:</b></p> <ul style="list-style-type: none"> <li>(a) Due to low strength of materials at high-temperature power requirement is low.</li> <li>(b) A very large workpiece can be deformed with equipment of reasonable size.</li> <li>(c) Due to high ductility at high-temperature and absence of work hardening, large deformations can be undertaken in a single stage and complex parts can be fabricated.</li> <li>(d) Interstage annealing and stress relieving are not required.</li> <li>(e) Blow holes and porosities are eliminated by welding action at high-temperature and pressure.</li> </ul> <p><b>Disadvantages:</b></p> <ul style="list-style-type: none"> <li>(a) Poor dimensional accuracy and surface finish, material loss due to oxidation and scaling.</li> <li>(b) Thin parts cannot be produced due to loss of ductility because of the high rate of loss of heat.</li> <li>(c) Higher cost to heat the metal.</li> <li>(d) Automation is difficult due to high working temperature.</li> <li>(e) Reduces hardness and strength due to decarbonization.</li> </ul>

#### 21.1.1 Advantages of Mechanical Working Process Over other Manufacturing Processes

- (a) They have higher productivity compared to other manufacturing processes.
- (b) Forged products have higher strength, better corrosion and wear resistance as compared to the casting and machined processes.

- (c) There is minimum wastage of materials.
- (d) The forged products have high dimensional accuracy and surface finish.
- (e) Some special products like thin foil, wire, sheet steel and other products can be manufactured by only mechanical working.

**Recrystallization Temperature:** According to ASME (American society of mechanical engineers). The recrystallization temperature is defined as “the approximate minimum temperature at which the complete recrystallization of cold worked metal occurs within a specified period of time. Recrystallization reduces the strength and increases the ductility of the metal.

Factors which affect the recrystallization temperature:

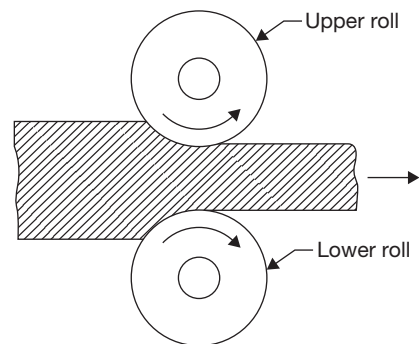
- (a) Grain size: Smaller grain size decreases recrystallization temperature.
- (b) The function of time: Recrystallization temperature depends on the function of time of heating.
- (c) Type of metal: For pure metal, it is lower in comparison to alloys.
- (d) The extent of prior cold work: Higher the prior cold work, lower will be recrystallization temperature.
- (e) Rate of deformation: Increasing the rate of deformation decreases the recrystallization temperature.

For pure metal, critical temperature,  $(T_{cr}) = 0.3 T_m$ .

For Alloys,  $T_{cr} = 0.5 T_m$ , where,  $T_m$  is a melting temperature.

## 21.2 ► ROLLING

Rolling is the process of reducing the thickness or changing the cross-sectional area of the workpiece by means of rolling mills. It is performed through hot working or cold working. The metal is drawn into the opening between the rolls by frictional forces between the metal and roll surface as shown in Figure 21.1. The metal is subjected to high compressive force between the rolls for deformation.



**FIGURE 21.1**

A Schematic Diagram of Rolling Process

### 21.2.1 Terminology

**Bloom:**  $150 \times 150 \text{ mm}^2$  to  $250 \times 250 \text{ mm}^2$ .

**Billet:**  $50 \times 50 \text{ mm}^2$  to  $125 \times 125 \text{ mm}^2$ .

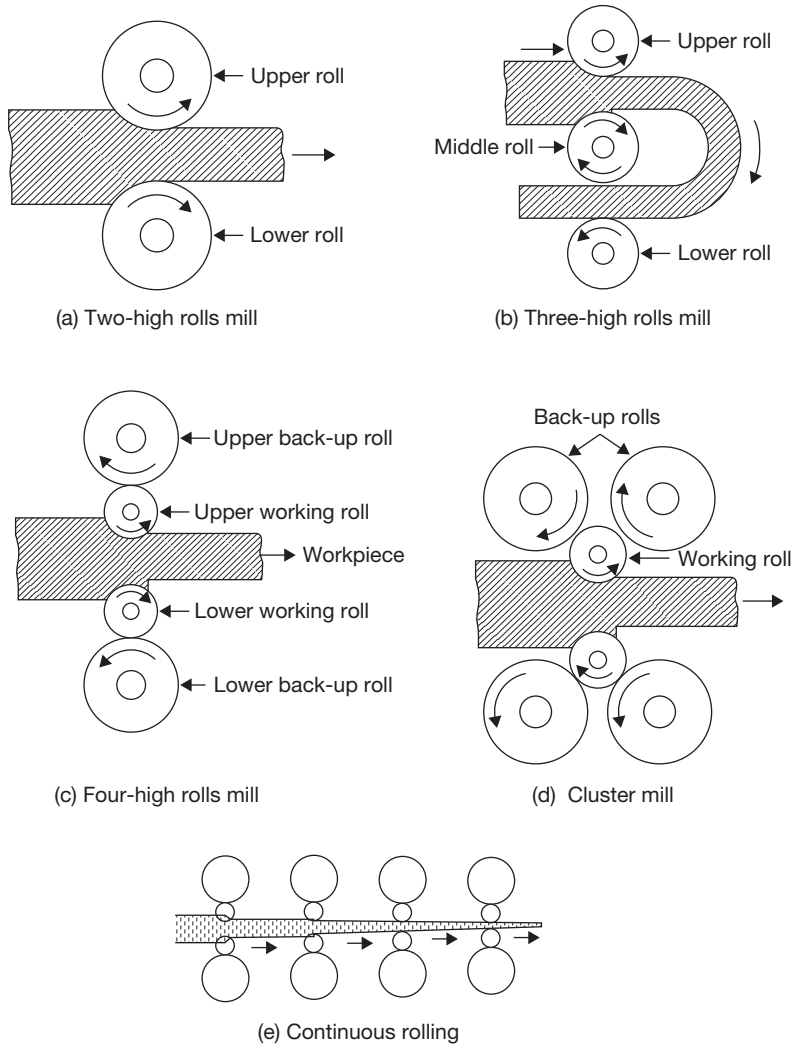
**Slab:** Thickness: 50 to 150 mm, Width: 0.6 to 1.5 m.

**Sheet and Plate:** Maximum thickness: 6.35 mm.

**Foil:** 1.5 mm thickness.

### 21.2.2 Types of Rolling Mills

The different types of rolling mills are shown in Figure 21.2.



**FIGURE 21.2**

Types of Rolling Mills

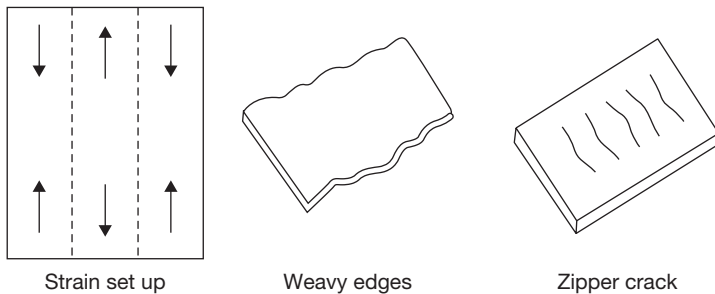
In two high rolls mill (Pullover), the stock is returned to the entrance for further reduction. In two-high mill (reversing), the work can be passed back and forth through the rolls by reversing their direction of rotation. In three high rolls mill, upper and lower rolls are the driver and the middle roll rotates by friction. In four high rolls mill, small-diameter rolls

of less strength and rigidity are supported by larger-diameter backup rolls. In cluster mill, each of the work rolls is supported by two backing rolls. Continuous rolling uses a series of rolling mill and each set is called a stand. The strip moves at different velocities at each stage in the mill.

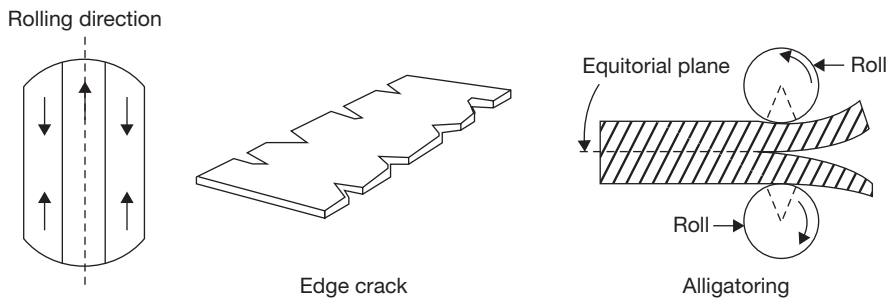
### 21.2.3 Rolling Defects

There are two types of rolling defects: Surface Defects and Internal Defects as shown in Figures 21.3 and 21.4 respectively.

- (a) Surface defects: Scale, rust, scratches, cracks, pits, and gouges.
- (b) Internal structural defects: Wavy edges, crack in the center of the sheet (Zipper cracks), edge cracks, folds, etc.



**FIGURE 21.3**  
Surface Rolling Defects



**FIGURE 21.4**  
Internal Rolling Defects

## 21.3 ► FORGING

Forging is a process of plastic deformation for shaping. The force applied in this case is an intermittently compressive force while in a rolling process force applied is a continuous compressive force.

### *Advantages*

- ▶ Homogeneous distribution of impurities.
- ▶ Porosity, voids and blow holes are largely eliminated.
- ▶ Refinement of grains and increase in strength.
- ▶ Fiber flow lines are properly directed, hence, better mechanical properties.
- ▶ Close dimensional tolerance, smooth surface.

### *Disadvantages*

- ▶ Poor surface finish due to oxidation and scaling of the surface in hot forging.
- ▶ High operation cost.
- ▶ Complicated shape cannot be produced by this process.

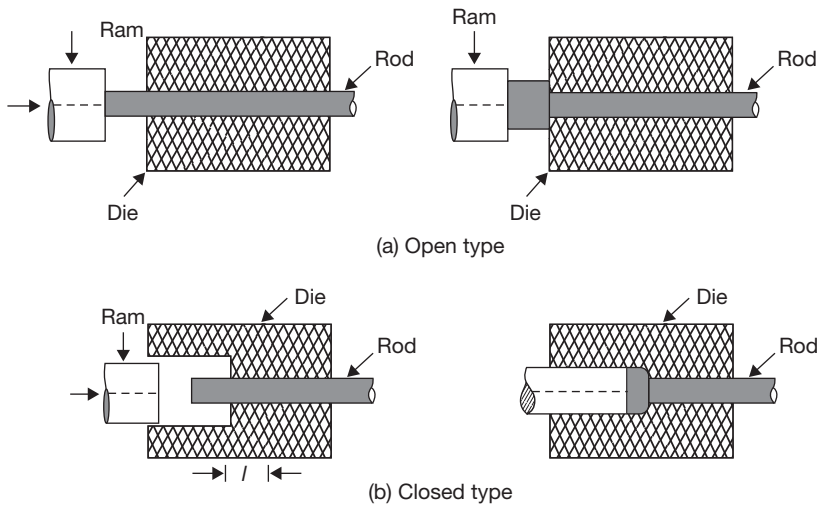
### 21.3.1 Different Types of Forging

#### *Open Die Forging*

In open die forging, the hot workpiece is placed between two flat dies and is hammered to produce the desired shape. There is no flow of metal in this process. This is a slow process and may be performed by presses in addition to hammer (Figure 21.5a). It is repeatedly manipulated between the dies until the final shape is achieved. Cogging is a successive deformation of a bar along its length using an open-die drop forge. It is commonly used to work a piece of raw material to the proper thickness. Once the proper thickness is achieved the proper width is achieved via edging. Edging is the process of concentrating material using a concave shaped open die. The process is called edging because it is usually carried out on the ends of the workpiece. Fullering is a similar process that thins out sections of the forging using a convex shaped die. These processes prepare the workpieces for further forging processes.

#### *Limitations of Open Die Forging*

- ▶ It is limited to short run production.
- ▶ It has less control on mechanical properties and dimensions.
- ▶ It is restricted to simple shapes only.
- ▶ Machining is often required after forging.
- ▶ It has poor material utilizations.

**FIGURE 21.5**

Open and Closed Die Forging

### *Closed Die Forging*

This is a variation of impression-die forging without flash (Figure 21.5b). It has better utilization of material than open flat dies, better physical properties, closer dimensional tolerance, high production rate, etc. In impression-die forging the heated workpiece is placed between two required shaped die and is pressed or hammered. During hammering or pressing it takes the shape of the die. A small amount of material is forced outside the die impression, which is finally trimmed. The flash helps to build up pressure on the material between the dies which ensures the filling of dies cavity.

#### *Advantages*

- ▶ There is saving of time because trimming is not required in this process.
- ▶ There is a better utilization of work materials.
- ▶ It has excellent reproductivity with good dimensional accuracy.
- ▶ Forging of complicated shape may be made.
- ▶ The products have good mechanical properties due to proper control of grain flow of the metal.
- ▶ It has high production rate.

#### *Disadvantage*

- ▶ Tooling cost is high, therefore, it is suitable for a large production run.

### *Drop Forging*

In this forging, the metal is deformed by the impact of a hammer or die and hot metal is forced to conform to the die shape. The proper flow of metal during the intermittent blows is ensured and operation is divided into a number of steps. Each step changes the shape of the workpiece progressively. For complex forgings, more than one set of dies may be required.

### *Press Forging*

Press forging employs a slow squeezing action produced by mechanically or hydraulically operated press as compared to rapid impact blows of hammer in drop forging. The slow squeezing action penetrates completely through the metal producing a more uniform deformation and flow of metal during the process. In this process, there is maximum utilization of energy by the workpiece while in drop forging some part of the energy is transferred to machine and foundation. The dimensional accuracy is also very good in this process.

#### *Advantages of Press Forging over Drop Forging*

- ▶ It produces low noise level.
- ▶ It is faster than drop forging since only one squeeze is needed at each die impression.
- ▶ Control of two die halves is easier than hammering in drop forging.
- ▶ The product has superior structural quality.

### *Upset Forging*

Upset forging is used to produce heads in bolts, screws, bars, etc. Only a certain portion of the material is deformed and the rest is unaffected by the deformation. Upset forging generally employs split dies that contain multiple positions or cavities and may be of the open and closed type. The heated bar or rod is positioned in the die and clamped. A hydraulic ram moves longitudinally against the bar, upsetting it into the die cavity.

In open upset forging, the unsupported length ( $l$ ) of the rod does not exceed  $3d$  to prevent its buckling, ' $d$ ' being rod diameter. If  $l > 3d$ , then closed upset forging is preferred with die diameter,  $D \leq 1.5d$ .

#### *Advantages*

- ▶ It has better forging quality than obtained by drop forging.
- ▶ There is very little flash.
- ▶ It has cheaper maintenance and higher productivity.
- ▶ The upsetting process can be automated.

#### *Disadvantages*

- ▶ It is not suitable for forging of the heavier job.
- ▶ The maximum diameter of the stock which can be upset is limited (about 25cm).

- ▶ Intricate nonsymmetrical and heavy jobs are difficult to be forged by this process.
- ▶ It has high tooling cost.

### *Defects in Forging and its Remedies*

- Cold Shuts or Laps*: It is short cracks at the corners and at right angles to the surface. It is caused by metal surface folding against itself during forging. Sharp corners in dies can result in hindered metal flow which can produce laps. It can be eliminated by proper design of die; the crack on the surface is removed by machining or grinding.
- Pitting*: Pitting of the forging surface is caused by scale, which if not removed thoroughly from the die cavity is worked into the surface of forging. When this scale is cleaned from the forging depression remains which are known as 'Scale pits'. Pitting may be avoided as much as possible during manufacture of forging by proper control of furnace and frequent cleaning of dies.
- Die Shift*: Die shift is caused by misalignment between the top and bottom forging dies. This may be caused due to loose wedges.
- Incomplete filling dies*: This defect may occur due to an insufficient number of blows during forging, the wrong amount of metal, forging at too low-temperature, poor forging and die design, etc.
- Burnt and Overheated Metal*: This defect is caused by improper heating conditions and soaking the metal too long.
- Fins*: Fins are small projections or loose metal driven into the surface of the forging.
- Ruptured Fiber Structure*: This is a discontinuity in the flow lines of the forging which is revealed only when observing the microstructure. This defect is caused by working some of the alloys too rapidly during the forging operation, inadequate stock size or improper die design.
- Cracks*: It occurs on the forging surface which may be longitudinal or transverse. Their occurrence may be due to the poor quality of ingot, improper heating, forging at low-temperature or incorrect cooling of alloy steel forging.
- Decarburization*: If the raw stock is subjected to high-temperature for too long period. It can produce decarburized surface on the forgings, particularly in high carbon steels.

## 21.4 ► EXTRUSION

Extrusion is a primary shaping process in which a metal kept in a cylinder is forced to pass through the opening of a die. The metal is subjected to plastic deformation and it undergoes reduction and elongation during extrusion.

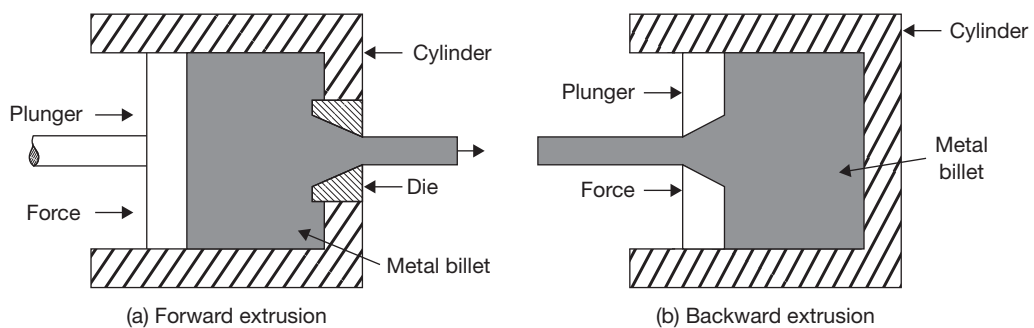
There are two types of extrusion—hot extrusion and cold extrusion.



### 21.4.1 Hot Extrusion

In a hot extrusion the metal billet is heated up to a plastic state and put into a cylinder and it is forced to flow through the opening of a die. On the basis of the direction of flow of the metal with respect to the direction of the force applied hot extrusion is divided into two classes: forward extrusion and backward extrusion.

In forward extrusion, plunger moves in a forward direction and the metal is forced through the die opening in the same direction but in the backward direction, metal forced through the die opening in plunger itself in the backward direction as shown in Figure 21.6.



**FIGURE 21.6**

Forward and Backward Extrusion

Backward hot extrusion involves no friction between the metal billet and chamber walls because the billet does not move in the chamber compared with the forward hot extrusion. Total force required due to low friction in the backward extrusion is less but equipment used is more mechanically complicated in order to accommodate the passage of the extruded shape through the center of the plunger.

### 21.4.2 Cold Extrusion

Cold extrusion is carried out at room temperature. Because of the large forces required in extrusion, most metals are extruded hot where the deformation resistance of a metal is low. At the same time strain hardening is also eliminated in hot extrusion.

### 21.4.3 Impact Extrusion

It is essentially a cold process which is mostly used for making collapsible medicine tubes, toothpaste tubes, shaving cream tubes and food canes from more ductile metals such as zinc, lead, tin, aluminum, copper, etc. During the process, the billet is placed in a die cavity and is given a strong single blow through the punch which causes the metal to flow plastically

around the punch. The tube thickness is controlled by the clearance between the die and punch. Impact extrusions are low in cost and have an excellent surface finish.

### Advantages of Extrusion Process

- ▶ The surface finish of the product is quite smooth with relatively close tolerance.
- ▶ High production rate since it is a very rapid process.
- ▶ A very dense structure of the metal is obtained because of high-pressure used and compressive nature of the process.
- ▶ It is an ideal process for producing parts of uniform cross section in large quantities.
- ▶ Cheaper than pressure die casting.

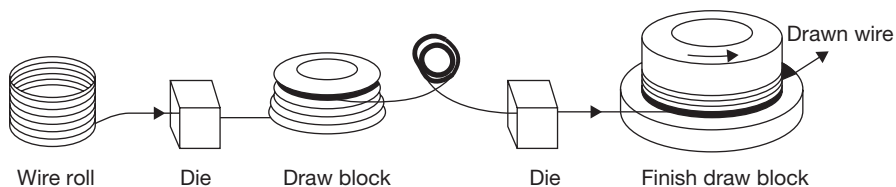
(Extrusion ratio,  $R$  for Steel = 40:1, and for Aluminum = 400:1)

$$\text{Where, } R = \frac{\pi r_i^2}{\pi \cdot r_f^2}; \quad r_i = \text{radius of billet, } r_f = \text{radius of extruded part.}$$

## 21.5 ► WIRE DRAWING

Wire drawing is a process to produce a small diameter wire from billet by applying tensile force. A leading end of a wire to be drawn is pointed in a rotary-swaging machine or by some other means. The point is then inserted into the die; and the wire point is properly gripped and pulled sufficiently by a suitable means so that the end can be attached to the power reel as shown in Figure 21.7. Then the power reel rotates at the proper speed and pulls the entire piece through the die opening which actually contacts the workpiece, is a smoothly surfaced, truncated, conical opening in a material of the opening is never in contact with the wire being drawn but is filled with lubricant.

The die angle depends upon the metal to be drawn including its hardness from previous cold working and the reduction of area to be affected. A die angle of about  $12^\circ$  is average for the drawing of steels with carbide. Two lubricant methods are currently employed. The mechanism of wire drawing is shown in Figure 21.8. In one method, the wire surface is cleaned, coated with lime, and this is thoroughly dried. Before, entering the die lubricant such as a grease or soap is applied to this surface. The dried lime coating helps to hold this

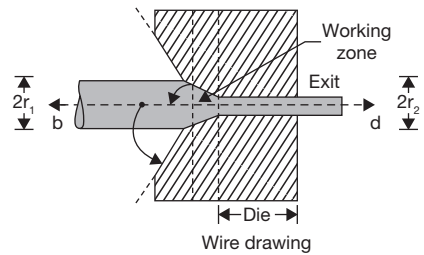


**FIGURE 21.7**

Wire Drawing Process

lubricant to the surface as it passes through the die. In the other method, the surface of the wire is first coated with copper or tin. Then, as the metal enters the die, a water carried lubricant is applied. This method is more suitable for final drafts of fine wire.

Considerable heat is generated during a wire drawing operation, and water may be circulated around the die to cool it. When the metal of the wire has reached its work hardening limit, annealing is necessary before additional drawing can be done.



**FIGURE 21.8**

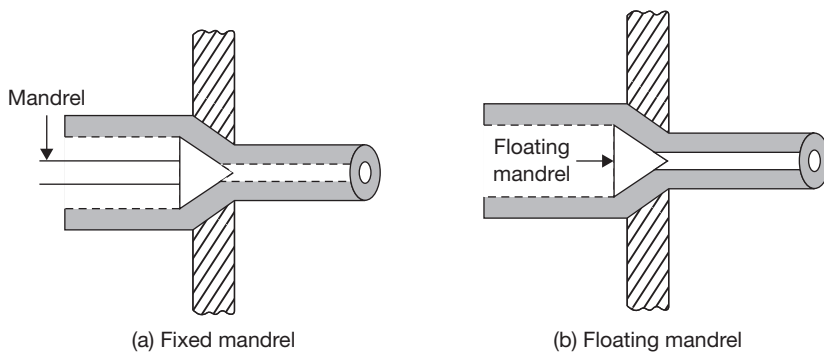
Mechanism of Wire Drawing

## 21.6 ► BAR DRAWING

An important difference between the bar drawing and wire drawing is that the bars must remain straight. The length of the bar which can be drawn is limited by the maximum travel of the carriage, which may be from 50 to 100 feet. The first operation, preliminary to drawing is the pointing of the bars by rotary swaging or hammer. After the pointed end is inserted into the die and gripped by the jaws of the carriage, the hook is lowered to engage the moving chain.

## 21.7 ► TUBE DRAWING

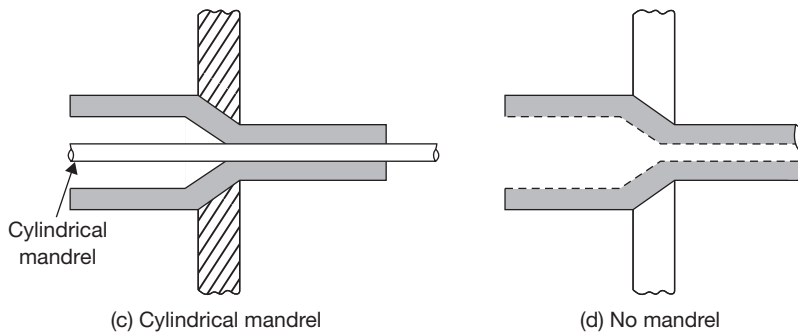
Like bar drawing, tube drawing is accomplished in most cases with the use of draw bench. Fixed mandrel (Figure 21.9 (a) is most commonly used to control the tube's internal diameter; Figure 21.9 (b) uses floating mandrel which adjusts itself to the correct position because of its stepped contour; cylindrical mandrel (Figure 21.9 (c) is usually used for small sized tubing, and Figure 21.9 (d), which uses no mandrel or rod and has no control over inside



**FIGURE 21.9**

Tube Drawing Processes

(a) Fixed Mandrel; (b) Floating Mandrel

**FIGURE 21.9**

Tube Drawing Processes

(c) Cylindrical Mandrel; (b) No Mandrel

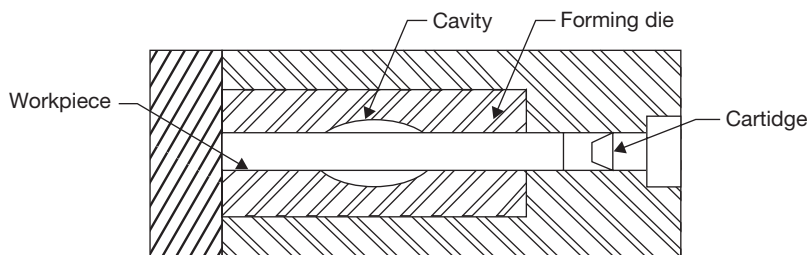
diameter. By repeated cold drawing and annealing when necessary it is possible to reduce a 2-inch diameter to the size of hypodermic needle, which has an outside diameter of about 0.008 inch.

## 21.8 ► HIGH ENERGY RATE FORMING

If the rate of energy flow for forming is high, it is known as high energy rate forming. Energy used may be chemical, magnetic and electro discharge, etc. In high energy rate forming, operation is performed in very less time. Explosive forming, electro-hydraulic forming, and electromagnetic forming are the examples of high energy rate forming.

### 21.8.1 Explosive Forming

In the explosive forming (Figure 21.10), a shock wave is generated in a fluid medium by detonating an explosive charge. The entire wavefront is utilized in a confined space.

**FIGURE 21.10**

Explosive Forming

But, for the large object, the wavefront may be used for unconfined space and it is less effective than confined space. The typical explosives include TNT and dynamite for higher energy and gun powder for lower energy. With high explosives placed directly over the workpiece, pressure up to  $35 \text{ kN/mm}^2$  can be generated. With low explosives, the pressure is limited to  $350 \text{ N/mm}^2$ .

### **21.8.2 Electrohydraulic Forming**

Electric discharge in the form of sparks in the place of explosives can also be used to generate a shock wave in a fluid. An operation using the principle of generating a shock wave is called electro-hydraulic forming. The characteristics of this process are very similar to those of explosive forming. The capacitor bank is charged through the charging circuit; subsequently, the switch is closed resulting in a spark within the electrode gap to discharge the capacitors. The energy level in this process is lower than in explosive forming. The peak pressure developed over the workpiece is a function of the amount of energy discharged (through the spark) and the standoff distance.

### **21.8.3 Electromagnetic Forming**

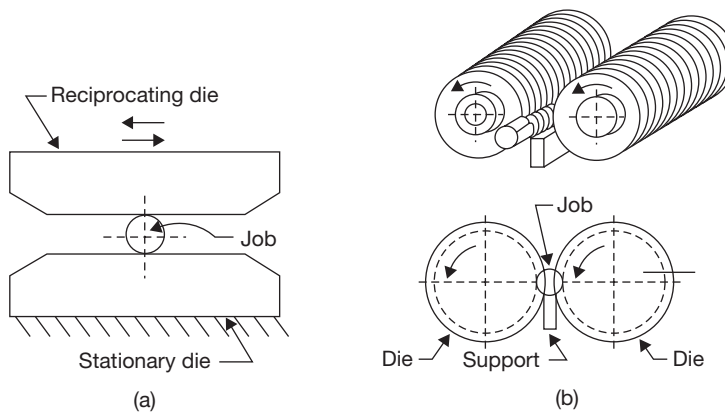
Just as in electro-hydraulic forming, the electrical energy is first stored in a capacitor bank. This energy is then discharged through a coil by closing the switch. The coil produces a magnetic field, the intensity of this field depends on the value of the current. Since the metallic workpiece is in this magnetic field, a current is induced in the job which sets up its own magnetic field. The directions of these fields are such that the rigidly held coil repels the workpiece into the die. The workpiece obviously has to be electrically conductive but need not be magnetic. The short life of the coil is the major problem in such an operation.

## **21.9 ► THREAD ROLLING**

In thread rolling there is no chips formation, i.e., the threads are produced by plastic deformation. Two types of machines are used, namely reciprocating flat die machine and rotating cylindrical die machine.

In a flat die method (Figure 21.11 (a)) the cylindrical blanks are automatically fed from a hopper and placed upon a stationary flat hardened steel die plate. Another flat hardened steel die plate which reciprocates and advances and rolls the blank along between them until the thread is complete.

The rotating cylindrical die method (Figure 21.11 (b)) may involve either two or three cylindrical dies having a negative impression of the threads. These dies are rotated together on parallel axes, which may be horizontal or vertical. If two cylindrical dies are used, the

**FIGURE 21.11**

Thread Rolling Processes

shafts are normally horizontal and sufficient additional support for the blank between them must be provided. After the blank has been placed on the support, two rotating dies move toward each other to impress the thread on the rotating blank. Cylindrical die machines are more suitable for larger threads, over 3/8 inch outside diameter.

### Advantages

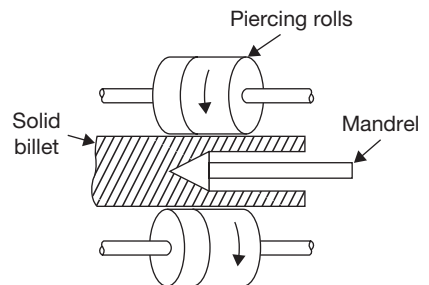
- ▶ They are cheaper in sufficiently large quantities.
- ▶ They are stronger on a result of the cold working and favorable fiber flow line positioning.

### Limitations

- ▶ It is not suitable for producing internal threads.
- ▶ It involves excessive costs in smaller quantities.

## 21.10 ► PIERCING OR SEAMLESS TUBING

It is a method to produce seamless tubes. The piercing machine consists of two taper rolls and a cylindrical hot billet passed between these rolls over a mandrel as shown in Figure 21.12. Both the rolls revolve in the same direction and the billet is center punched. The hot billet is pushed forward into the rolls. The rolls grip the billet and pull it. The axes of rolls are crossed at  $10^{\circ}$ – $12^{\circ}$  so that they revolve the billet as well as

**FIGURE 21.12**

Piercing or Seamless Tubing

draw it in forward direction and force onto the mandrel. The mandrel can also revolve in its own position. The combination of the revolving motion of the billet and mandrel together with the axial advancement of the billet provides a helical roiling effect of the billet material over the mandrel. If a tube of the larger bore is required, a second piercing operation is required after the completion of the first piercing operation.

### **21.11 ► SOME OTHER FORMING PROCESSES**

**Trimming:** The excess metal which remains around parting lines or around other edges after previous operations, such as forging, die-casting and drawing of sheet metal parts is removed by “trimming”. Trimming die is similar to blanking die and the parts are forced through the die by a suitable punch.

**Shaving:** A very small amount of metal (about 10% of the metal thickness) is removed or “shaved” from blanked or pierced edge in order to obtain edges which are smooth, square, and within closer dimensional tolerances. The parts to be shaved are placed in a locating recess above the die opening and during the downward stroke of the punch, the edge is shaved as the part is forced through the die.

**Notching:** Notching is the cutting of relatively small indentations in the edge of workpieces. A rubber, used for only small quantities of workpieces, is designed to remove, by a notching action, some metal from an edge of a workpiece.

**Embossing:** The production of raised or projected designs in relief on a surface is known as “embossing” sheet metal may be embossed between two matching die halves and the operation consists of a combination of drawing and stretching.

**Coining:** Coining consists of placing a proper amount of metal within a confined de space and exerting sufficient pressure to cause the metal to flow to all properties of the die cavity. The metal is caused to flow in directions perpendicular to the corresponding force along the de surfaces. Since lubrication is not used when good impression details are required, the compressive force required may be enormous.

**Peening:** This method is employed to set up a superficial state of surface compressive stress, causing the interior of the member to assume an opposite tensile stress. Because fatigue generally occurs from surface cyclically loaded in tension, the useful lives of such member are frequently extended by shot peening.

**Hobbing:** It is a method of making moulds for the plastic and die casting industries. A punch from tool steel to the shape of the cavity, heat treated for hardness, and polished. It is then pressed into a blank of soft steel method is that one hob properly applied can make a number of cavities in one mould or in a series of mould.

## SHEET METAL PROCESS

## 21.12 ► INTRODUCTION

Sheet metal is thin and flat pieces of metals. It is one of the fundamental forms used in the metal working, and can be cut and bent into a variety of different shapes. Countless everyday objects are constructed of the material. Thicknesses can vary significantly, although extremely thin thicknesses are considered as foil or leaf, and pieces thicker than 6 mm (0.25 inch) are considered plate. In this text, we will discuss the basic operations in sheet metal.

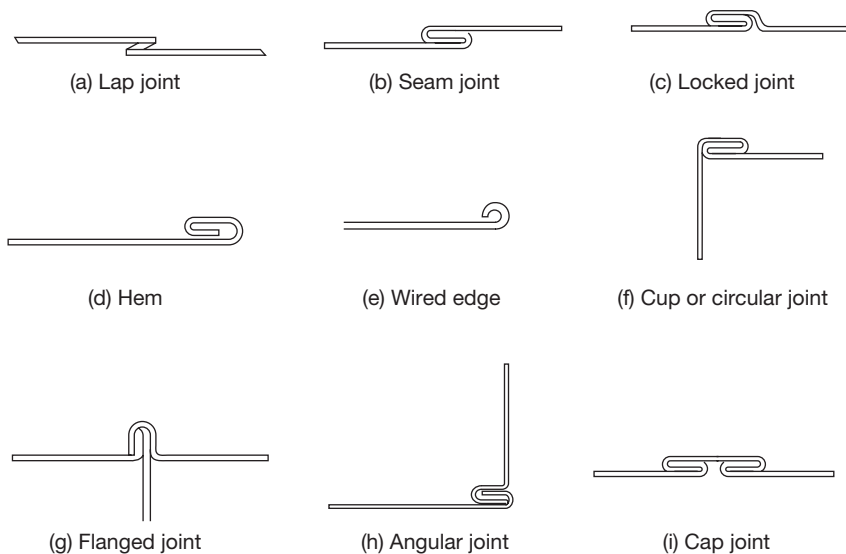
## 21.13 ► SHEET METAL JOINTS

Figure 21.13 shows the common types of sheet metal joints.

**Lap Joint:** It is the simplest and common type of joint that can be prepared by means of soldering or riveting processes.

**Seam Joint:** A seam is a joint made by fastening two edges to each other.

**Hem Joint:** Hem is an edge or border made by folding. It stiffens the sheet and does away with the sharp edge. Generally, two types of Hem joint—single hem and double hem are there. Single Hem joints are made by folding the edges of the sheet over once to make it



**FIGURE 21.13**

Sheet Metal Joints



smooth and stiff while the double hem is made by folding the edges over twice to make it smooth and stiff.

**Wired Edge:** The wired edge is smooth and very strong as it is prepared by folding the edges along a piece of wire.

**Flange Joint:** It is commonly used in making pipe connection.

**Angular and Cup Joint:** Angular and cup joints are mainly used for joining two pieces at an angle of 90°.

**Cap Joint:** It is a useful form of locked-seam. Soldering or riveting or both processes are generally used with this type of joint to make it more effective in the practical field.

## **21.14 ► MATERIALS USED FOR SHEET METAL**

The sheet of black iron, tin, galvanized iron (GI), stainless steel, copper, zinc, and aluminum, etc., are widely used in tin smithy work. The sheets are specified by gauge numbers. The larger the gauge number, the lesser the thickness.

**Black Iron Sheet:** It is the cheapest type of metallic sheet. It has a bluish-black appearance and is often referred to as uncoated sheet. The use of this sheet is limited to articles that are to be painted after fabrication work such as tanks, stoves, and pipes.

**Galvanized Iron (GI) Sheet:** The zinc coating resists rust and improves the appearance of the metal and permits it to be soldered easily. Welding work on this sheet is not so easy as zinc gives toxic fumes and residues. As it is coated with zinc, galvanized iron sheet withstands contact with water and exposure to weather. It is mainly used to make the articles such as furnaces, cabinets, buckets, pans, and gutters, etc.

**Tin Sheet:** This is an iron sheet coated with the tin to protect it against rust. This is specially used for soldering work as it is the easiest metal to join by a soldering process. It has the very bright silvery appearance and is used mainly in making of roofs, canes, pans, dairy equipment, and food containers, etc.

**Stainless Steel Sheet:** Stainless steel sheet used in tin smithy shop can be worked as galvanized iron sheet, but is tougher than galvanized iron sheet. Stainless steel is an alloy of steel with chromium and nickel. It has good corrosive resistance and can be welded easily. It is costly metal. This type of sheet is used in food processing items, chemical plants, canneries, dairies items and kitchen wares, etc.

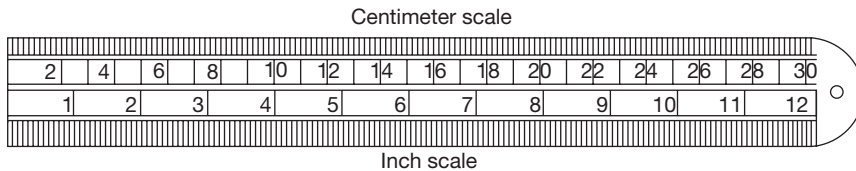
**Copper Sheet:** This type of sheet has a better appearance than other metals. The cost of copper sheet is higher in comparison to Galvanized iron sheet. Being resistant to corrosion, it is used for making the articles such as hoods, roof flashing, expansion joints and gutters, etc.

**Aluminum Sheet:** Aluminum cannot be used in pure form, but is used with a small amount of silicon, manganese, copper and iron. It is highly resistant to corrosion and abrasion, whitish in color and light in weight. It is now widely used in the manufacturing of a number of articles such as trays, refrigerators, household appliances, lighting fixtures, parts of airplanes, electrical and transport industries and in the fitting and fixture used in windows, doors and building requirements, etc.

### 21.15 ► HAND TOOLS USED IN SHEET METAL WORK

#### Steel Rule

It is particularly useful in measuring and laying out small size of work. It is shown in Figure 21.14.



**FIGURE 21.14**

Steel Rule

#### Steel Square

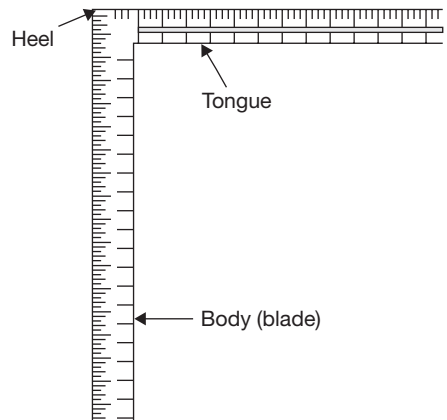
This is L-shaped hardened steel piece. It has two parts:

- (a) Tongue
- (b) Body

The narrow arm of the square is known as tongue while the wider part is called as the body as shown in Figure 21.14. It is used for checking the 90° between two adjacent surfaces and for making the line in a perpendicular direction to any baseline.

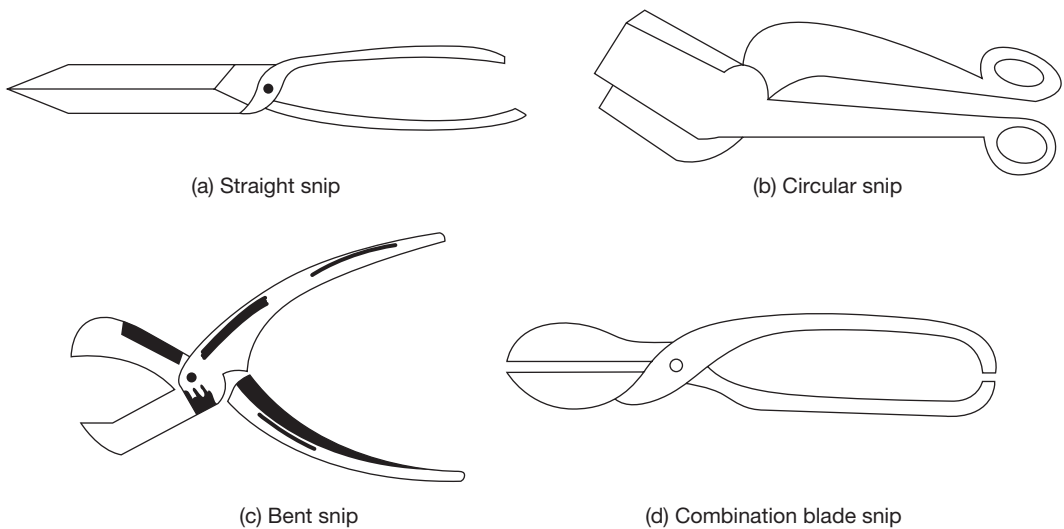
#### Snips

These are made of high carbon steel and used for cutting thin and soft metallic sheets. There are different types of snips (Figure 21.15) but straight and curved or bent types of snips are commonly used in practice. The straight snip or shear is used for cutting along a straight line while the curved or bent



**FIGURE 21.14**

Steel Square

**FIGURE 21.15**

Type of Snips

type of snip is used for cutting the sheet along a curvature. Both these snips are very light and can be easily handled by only one hand. A heavier class of snips is known as bench-strip or bench-shear which is fitted on the bench.

### *Punches*

These are also made of hardened steel. Punches are used for marking out work and to locate the center in a permanent manner. Punches may be divided into two types:

- (a) Prick Punch or Dot punch
- (b) Center Punch

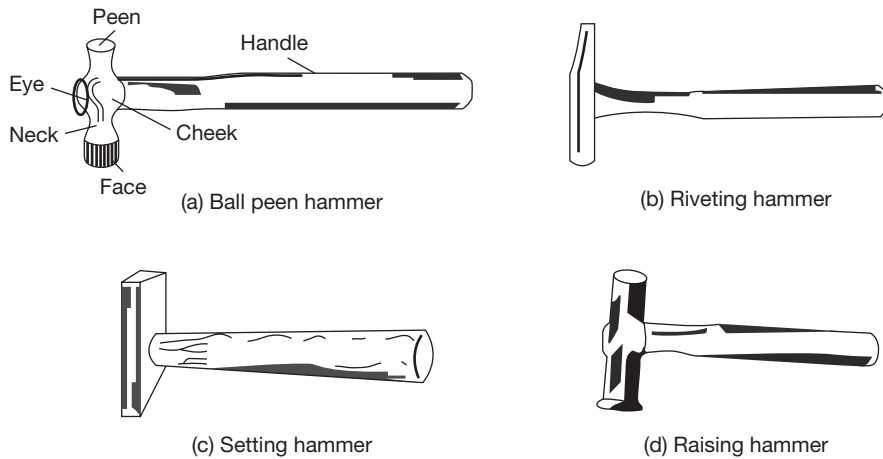
Prick punch is used to make small marks and to make this prick punch marks larger, we have to use a center punch. Center of the hole that is to be drilled is marked by a center punch.

### *Dividers*

It is made of hardened steel and generally used for drawing or scratching the circles or arcs on the metallic sheet.

### *Trammel*

It consists of a steel bar with two movable steel heads which have bottom part sharply pointed and hardened. The main function of this trammel is to draw large sizes of circles or arcs that are beyond the limit of dividers.

**FIGURE 21.16**

Type of Hammers

### Hammers

To suit the different types of work on the tin sheet, various sizes and shapes of hammers are used (Figure 21.16). They are made to have a square or round heads to suit for striking or hammering the corners and round surfaces respectively. If the peen of the hammer is straight and parallel to axis of hammer (handle), this is known as straight peen hammer; if the peen of the hammer is straight and perpendicular to axis of hammer (handle), this is known as straight peen hammer; and if the peen of the hammer is round, this is known as ball peen hammer. For avoiding the damage of sheet, soft faced hammers are frequently used.

### Mallet

This is also used for the striking purpose and made of hard rubber, lead, copper, or mostly of hardwood.

**FIGURE 21.17**

Mallet

### Pliers

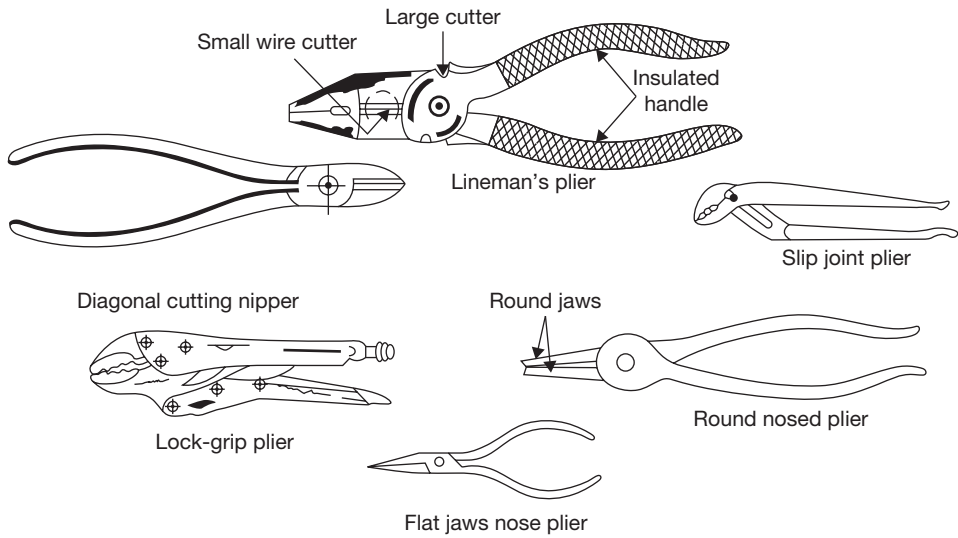
These are used for holding and forming the various shapes and patterns (Figure 21.18). In general, flat nose and round nose pliers are widely used.

### Slip Gauge or Thickness Gauge

It is also known as slip gauge and is used to measure the clearance between two assembled parts (Figure 21.19).

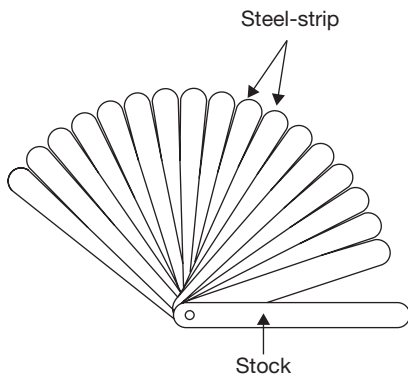
### Sheet Metal Gauge

This is used to measure the thickness of sheets as shown in Figure 21.20.



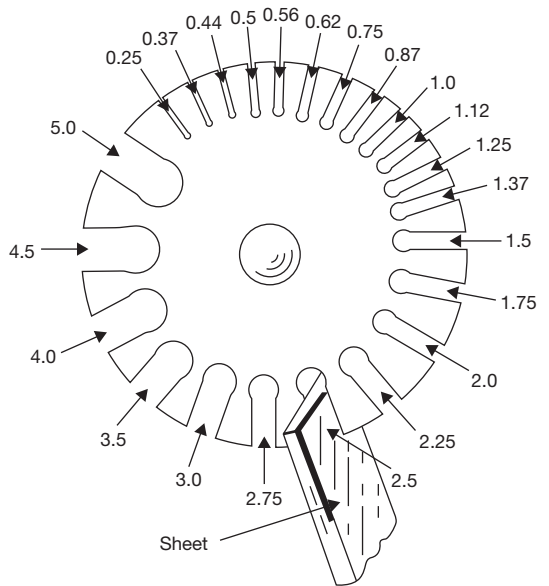
**FIGURE 21.18**

Pliers



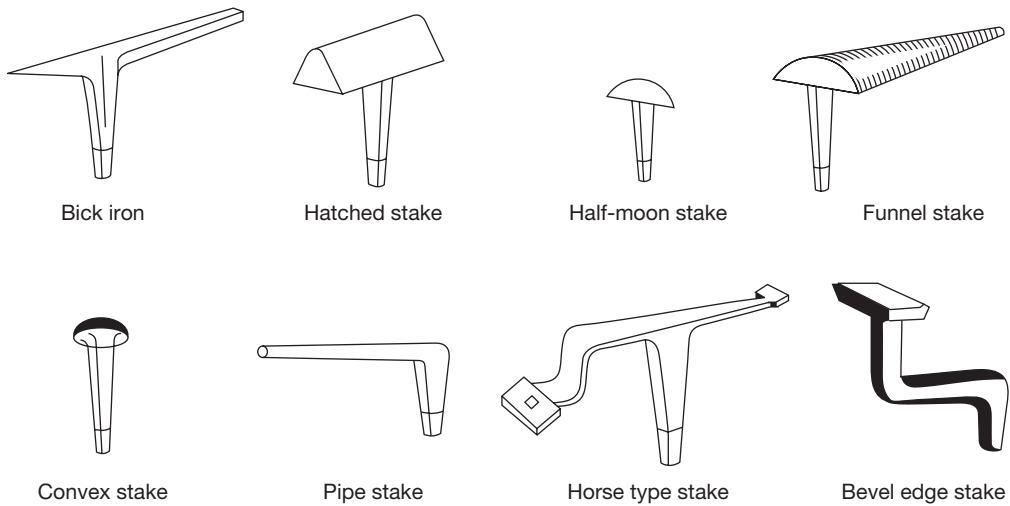
**FIGURE 21.19**

Slip Gauge



**FIGURE 21.20**

Sheet Metal Gauge

**FIGURE 21.21**

Type of Stakes

### Stakes

Stakes are used for seaming, bending or forming operations. They actually work as supporting tools as well as forming tools. As per nature of work some useful forms of stake are shown in Figure 21.21. In forming operation for long tapered cylindrical items, a bick iron is used while the hatched stake is preferred for forming, seaming and bending the edges. For conical work, a funnel stake is very useful. Half moon stake is very useful for working the edges on discs. For spherical work, a convex stake is preferred. Pipe stake is used for forming tubes. Horse type of stake is used for bending and general work for holding and supporting the other stakes.

## 21.16 ► SHEET METAL OPERATIONS

### 21.16.1 Shearing

It is a general name for a most sheet metal cutting operation in a specific sense. It designates a cut in a straight line across a sheet, bar or strip. It shows clean edges on the metallic job that is to be sheared or cut. Some of the basic shearing operations are described below:

#### *Punching and Blanking*

Punching is a process of producing a hole in a flat sheet while blanking is a process of cut out an intricate shape from the sheet which is known as blank (Figure 21.22). The main difference between punching and blanking is that the main ambition in punching holes but in

blanking cut out the intricate shape from the sheet. Generally, punching is also called piercing but in piercing the hole is produced in the sheet without removing the metal. There are following points which must be considered during the design of punching and blanking:

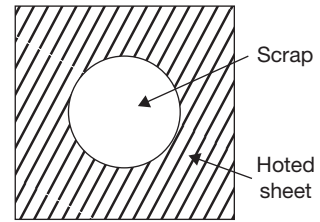
- (a) Clearance provided on the die or punch = 10% of the strip thickness.
- (b) In punching, clearance is provided on the die while in blanking, clearance is provided on the punch.
- (c) The shear angle is provided on die in blanking, and on punch in punching.

*Perforating:* This is a process of punching a number of holes in a sheet.

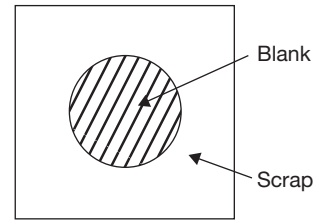
*Parting:* This is a process of shearing the sheet into two or more pieces.

*Notching:* This is a process of removing pieces from the edges.

*Lancing:* This is a process of leaving a tab without removing any material.



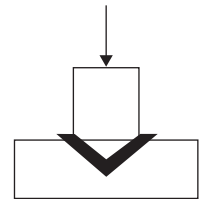
(a)



(b)

**FIGURE 21.22**

(a) Punching and (b) Blanking

**FIGURE 21.23**

Bending

### 21.16.2 Bending

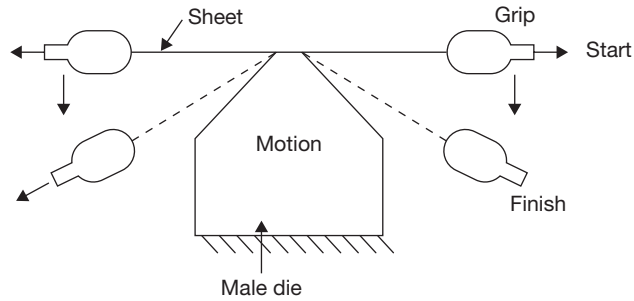
This is the forming process causes the sheet metal to undergo the desired shape by bending without failure (Figure 21.23).

### 21.16.3 Stretch Forming

In a stretch forming operation, a sheet metal is stretched to yield point in tension and then wrapped over and around the form block (die). This method has the advantage over other forming methods that spring back is either greatly reduced or completely eliminated, since direct bending stress is never introduced. All the plastic deformations occur in the direction of pulling force. Figure 21.24 shows that the jaws grip the work and first stretch and then the wrap it around the die. This method avoids most of the friction which somewhat limits the degree of forming obtainable with the moving die.

### 21.16.4 Deep Drawing

Deep drawing or drawing is defined as a process of making a cup-shaped part from flat sheet metal blanks. The blank is first heated to provide necessary plasticity for working.


**FIGURE 21.24**

Stretch Forming

The heated blank is then placed in position over the die or cavity. The punch descends and pushes the metal through the die to form a cup. So this process is also known as cupping (Figure 21.25).

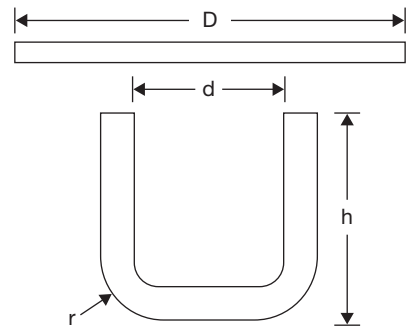
*Blank Diameter:* If  $D$  is the blank diameter in mm,  $r$  is the corner radius (in mm),  $h$  is the height of the shell as shown in Figure 21.25.

Then for thin shells whose wall thickness is  $t$  and bottom thickness is  $T$ ,

$$D = \sqrt{d^2 + 4dh}; \quad \text{for } 20 \leq \frac{d}{r}$$

$$D = \sqrt{d^2 + 4dh - 0.5r}; \quad \text{for } 15 \leq \frac{d}{r} < 20$$

$$D = \sqrt{d^2 + 4dh - r}; \quad \text{for } 10 < \frac{d}{r} < 15$$


**FIGURE 21.25**

Cupping or Deep Drawing

If wall thickness ' $t$ ' is not equal to bottom thickness ' $T$ ' which is also the blank thickness.

Since the volume before and after drawing are equal. Therefore,  $D = \sqrt{d^3 + 4dh \frac{t}{T}}$ .

To find a blank diameter for a shell of irregular cross-section equal the weight before and after when a sample is available.

$$D = 1.1284 \sqrt{\frac{w}{WT}}$$

where  $W$  – weight of finished shells (grams),  $w$  – weight of metal per cubic mm,  $t$  – thickness of blank (mm.)



*Number of Draws:* The number of draws is based on the ration of height and diameter of the cup as shown in the Table 21.1.

Table 21.1: Number of Draws in Deep Drawing

h/d	Up to 0.7	0.7-1.5	1.5-3.0	3.0-7.0
Number of draws	1	2	3	4

Where, *h*-depth of the cup, *d*-shell diameter, *D*-blank diameter.

$$\text{Percentage reduction} = \frac{D - d}{D} \times 100$$

Both the factor limit the reduction percentage top limit for the first draw in between 45 and 48% reduction. It is 30% for the second draw and 20% for the third and subsequent draws. The total reduction should not be increased to 70 to 75% when it should be annealed and reduction may again start at the maximum percentage, a number of draws do not exceed 3 to 4 in the way.

### 21.16.5 Hot Spinning

The parts having circular cross-section can be made by spinning from thin sheet metal. The principle of metal spinning is that a heated circular blank of sheet metal is lightly held against a chuck by the pressure of a freely rotating pad on the lathe tailstock. A rounded stick or roller is pressed against the revolving piece and moved in a series of sweeps as shown in Figure 21.26. This displaces the metal in several steps to conform to the shape of the chuck. Once the operation is started considerable frictional heat is generated which aids in maintaining the metal at a plastic state.

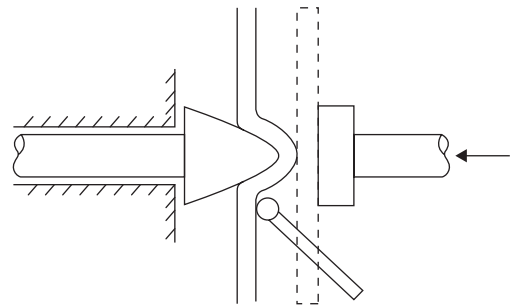


FIGURE 21.26

Hot Spinning

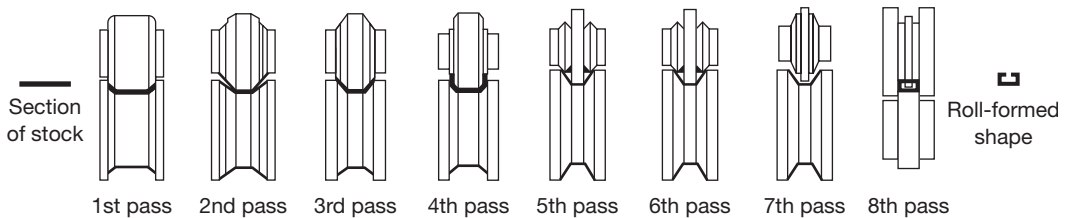


FIGURE 21.27

Eight-roll Sequence for the Roll Forming of a Box Channel

**Roll Forming:** Roll forming is a process by which a metal strip is progressively bent as it passes through a series of forming rolls.

## POWDER METALLURGY

### 21.17 ► INTRODUCTION

Powder metallurgy is a process of making components from metallic powders. Initially, it was used to replace castings for metals which were difficult to melt because of high melting point. The development of technique made it possible to produce a product economically, and today it occupies an important place in the field of the metallurgical process. The number of products made by powder metallurgy is increasing including tungsten filaments of lamps, contact points, self-lubricating bearings, and cemented carbides for cutting tools.

The manufacturing of parts by powder metallurgy process involves the following steps:

- (a) Manufacturing of metal powders
- (b) Blending and mixing of powders
- (c) Compacting
- (d) Sintering
- (e) Finishing operations

### 21.18 ► MANUFACTURING OF METAL POWDERS

#### 21.18.1 Characteristics of Metal Powder

The performance of metal powders during processing and the properties of powder metallurgy depends on the characteristics of the metal powders that are used. Following are the important characteristics of metal powders: (a) Particle shape, (b) Particle size, (c) Particle size distribution, (d) Flow rate, (e) Compressibility, (f) Apparent density, and (g) Purity.

#### 21.18.2 Methods of Production of the Metal Powders

There are various methods available for the production of powders. Some of the important processes are:

- (a) Atomization
- (b) Machining
- (c) Crushing and Milling
- (d) Reduction
- (e) Electrolytic deposition
- (f) Shotting
- (g) Condensation

*Atomization:* In this method, molten metal is forced through a small orifice and is broken into small particles by a powerful jet of compressed air, inert gas or water jet. These small particles are then allowed to solidify. These are generally spherical in shape. Atomization is mostly used for low melting point metals such as brass, bronze, zinc, tin, lead and aluminum, etc.

*Machining:* In this method, first chips are produced by filing, turning, etc., and then pulverized by crushing and milling. The powders produced by this method are coarse in size and irregular in shape. Hence, this method is used for only special cases such as the production of magnesium powder.

*Crushing and Milling:* These methods are used for brittle materials. Jaw crushers, stamping mills, ball mills are used to break down the metals by crushing and impact.

*Reduction:* Pure metal is obtained by reducing its oxide with a suitable reducing gas environment at an elevated temperature (below the melting point) in a controlled furnace. The reduced product is then crushed and milled to a powder. Sponge iron powder is produced this way.

*Electrolytic Deposition:* This method is specially used to produce iron and copper powders. This is similar to the electroplating process. To produce copper powder, copper plates are placed as anodes in the tank of electrolyte, whereas the aluminum plates are placed into the electrolyte to act as an anode. When D.C. current is passed through the electrolyte, the copper gets deposited on the cathode. The cathode plates are taken out from electrolyte tank and the deposited powder is scraped off. The powder is washed, dried and pulverized to produce a powder of the desired grain size.

*Shooting:* In this method, the molten metal is poured through a sieve or orifice and is cooled by dropping into the water. This produces spherical particles of large size. This method is commonly used for metals of low melting points.

*Condensation:* In this method, metals are melted and boiled to produce metal vapors and then condensed to obtain metal powders. This process is applied to volatile metals such as zinc, magnesium, and cadmium.

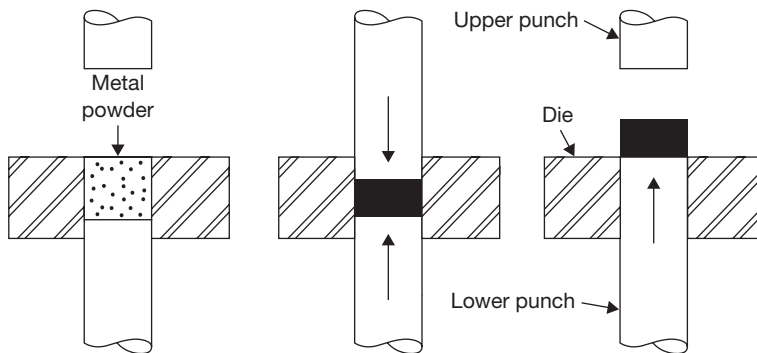
## **21.19 ► BLENDING/MIXING OF THE METAL POWDERS**

The proper mixing of the powders are essential for uniformity of the product. Lubricants (such as graphite) are added to the blending of powders before mixing. The function of the lubricant is to minimize the wear, to reduce friction. The different types of metal powders are thoroughly mixed in correct proportions in a ball mill, to control the mechanical properties of the products.

## 21.20 ► COMPACTING

The main purpose of compacting is converting loose powder into a green compact of accurate shape and size. The adopted for compacting are: pressing, centrifugal compacting, extrusion, gravity sintering, and rolling.

*Pressing:* The metal powders are placed in a die cavity and compressed to form a component shaped to the contour of the die (Figure 21.28). Mechanical presses are used for compacting objects at low-pressure. Hydraulic presses are for compacting objects at high-pressure.



**FIGURE 21.28**

Compacting (Pressing)

*Centrifugal Compacting:* In this method, the mold after it is filled with powder is rotated at high speed to get a compact of high and uniform density at a pressure of 3 MPa due to centrifugal force. This method is normally employed for heavy metals such as tungsten carbide.

*Extrusion:* This method is employed to produce the components with high density. Both cold and hot extrusion processes can be used. In cold extrusion, the metal powder is mixed with a binder and then this mixture is compressed in the form of a billet. The binder is removed before or during sintering. The billet is charged into a container and then forced through the die by means of a ram. The cold extrusion process is used for cemented carbide tools.

In the hot extrusion, the powder is compacted into a billet and is heated to extruding temperature in the non-oxidizing atmosphere. The billet is placed in the container and extruded through a die. This method is used for refractive Barium and nuclear solid materials.

*Gravity Sintering:* This process is used for making sheets for controlled porosity. In this process, the powder is poured on a ceramic tray to form a uniform layer and is then sintered up to 48 hours in ammonia gas at high-temperature. The sheets are then rolled to desired thickness. The porous sheet of stainless steel is made by this process and popularly used for filters.

*Rolling:* This method is used for making strips and rods having controlled porosity with uniform mechanical properties. In this method, the metal powder is fed between two rolls which compress and interlock the powder particles to form a sheet of sufficient strength. The metals that can be rolled are Copper, Brass, Bronze, Nickel, Stainless steel and Monel.

### **21.21 ► SINTERING**

Sintering involves heating of the green compact at high-temperatures in a controlled atmosphere to protect from the oxidation of metal powders. Sintering increases the bond strength between the particles. Sintering temperature is usually 0.6 to 0.8 times the melting point of the powder. In the case of mixed powders of different melting temperature, the sintering temperature will usually be above the melting point of one of the minor constituent.

### **21.22 ► FINISHING OPERATIONS**

These are secondary operations intended to provide dimensional tolerances, and better surface finish. They are—sizing, coining, machining, impregnation, infiltration, heat treatment, and plating.

*Sizing:* It is repressing the sintered component in the die to achieve the required size with accuracy.

*Coining:* It is repressing the sintered components in the die to increase density and to give additional strength.

*Machining:* Machining operation is carried out on sintered part to provide undercuts, holes, threads, etc., which cannot be removed on the part in the powder metallurgy process.

*Impregnation:* It is filling with oil, grease, or other lubricants in a sintered component such as bearing.

*Infiltration:* It is filling of pores of sintered product with molten metal to improve physical properties.

*Heat Treatment:* The processes of heating and cooling sintered parts are used to improve wear resistance, grain structure, and strength of the product.

### **21.23 ► ADVANTAGES OF POWDER METALLURGY**

- (a) There is a minimum loss of material.
- (b) The components produced are clean, bright and ready for use.
- (c) The composition of the product can be easily controlled.
- (d) Components can be produced with good surface finish and close tolerance.

- (e) Production rate is high.
- (f) Complex shapes can be produced.
- (g) A wide range of properties such as density, porosity and particle size can be controlled for a specific application.
- (h) There is usually no need for subsequent machining or finishing operations.
- (i) This process facilitates mixing of both metallic and non-metallic powders to give products of special characteristics.
- (j) Porous parts can be produced that could not be made any other process.
- (k) Less skilled labor can be employed.

### **21.24 ► LIMITATIONS OF POWDER METALLURGY**

- (a) The metal powders and the equipment are very costly.
- (b) Storing of powders offer great difficulties because of the possibility of fire and explosion hazards.
- (c) Parts manufactured by this process have poor ductility.
- (d) Sintering of low melting point powders like lead, zinc, tin, etc., is very difficult.

### **21.25 ► APPLICATIONS OF POWDER METALLURGY**

Powder metallurgy techniques are applied in the manufacturing of a different kind of products. Some of them are mentioned below as:

- (a) Self-Lubricating Bearing and Filters
- (b) Friction materials
- (c) Gears and Pump Rotors
- (d) Refractory materials
- (e) Electrical contacts and Electrodes
- (f) Magnetic materials
- (g) Cemented carbides

## **SMITHY**

### **21.26 ► INTRODUCTION**

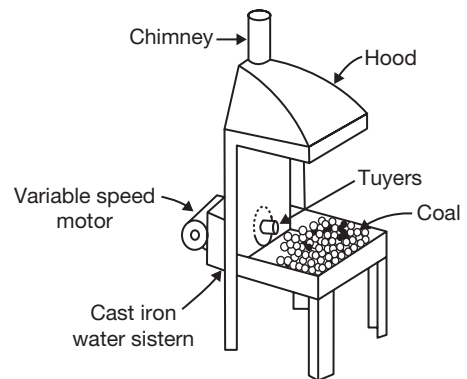
Smithy is a workplace where metal is worked with heating and hammering. A smithy's work is concerned with the heating of a metal stock to the desired temperature and enables it to obtain sufficient plasticity so that it can be given the desired shape by the operations like hammering, bending, pressing, etc.

These operations can either be carried out by hand hammering or power hammers. Hand hammering is the process in which forging is done by hand tools. Similarly, forging done with the help of power hammers is known as power forging. Applying pressure for deforming the metal for the required shapes, the primary requirement is to heat the metal to a definite temperature to bring it into the plastic state. This may be done either in an open hearth, known as Smith's forge or in the closed furnace, i.e., electric furnace or oil furnace. Smaller jobs are normally heated in the Smith's forge and larger jobs in closed furnaces. The hand forging process is employed for relatively smaller components and the power or machine forging is used for larger jobs requiring very heavy blows and drop forging for mass production of identical parts.

## 21.27 ► MAJOR TOOLS USED IN SMITHY SHOP

### 21.27.1 Smith's Forge or Hearth

It has a robust cast iron structure having four legs support, an iron bottom known as hearth, a hood at the top and tuyere opening into the hearth either from the rear or from the bottom as shown in the Figure 21.29. The hearth carries the coal and provided with bricks lining. Air, under pressure, is supplied through the tuyere opening in the hearth with the help of a blower. At suitable points, auxiliary pipes are used to connect the tuyere with the main pipeline. A valve is incorporated in the auxiliary pipe, just before the place where it is connected with the tuyere, to control the supply of air to the furnace. The chimney provided at the top to escape of smoke and gases produced due to the burning of coal. A water tank is provided, in front of the forge, which carries water for the purpose of quenching. The metal block is heated in at the coal bed up to plastic state before forging.

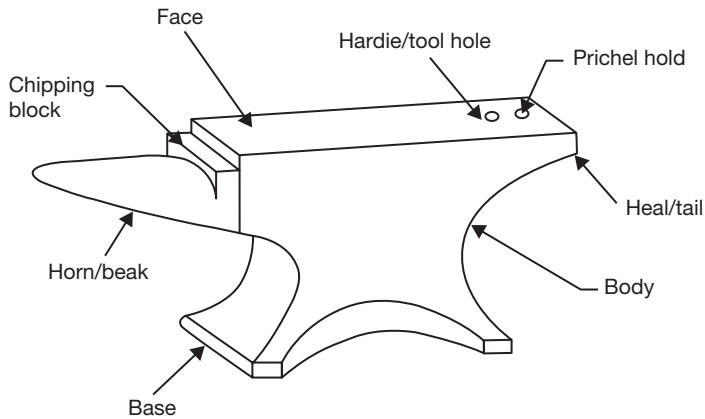


**FIGURE 21.29**

Smith's Forge or Hearth

### 21.27.2 Anvil

Anvil is a type of rigid support to the job to be forged or hammered. It has the capability to bear heavy blows rendered to the job as shown in the Figure 21.30. It is made of cast iron/wrought iron with a hardened top about 20 to 25 mm thick. It consists of a horn/beak, which is used to provide bend or curved shapes to the job. A flat step between the top and beak is provided to support the job during cutting and is known as chipping



**FIGURE 21.30**

Anvil

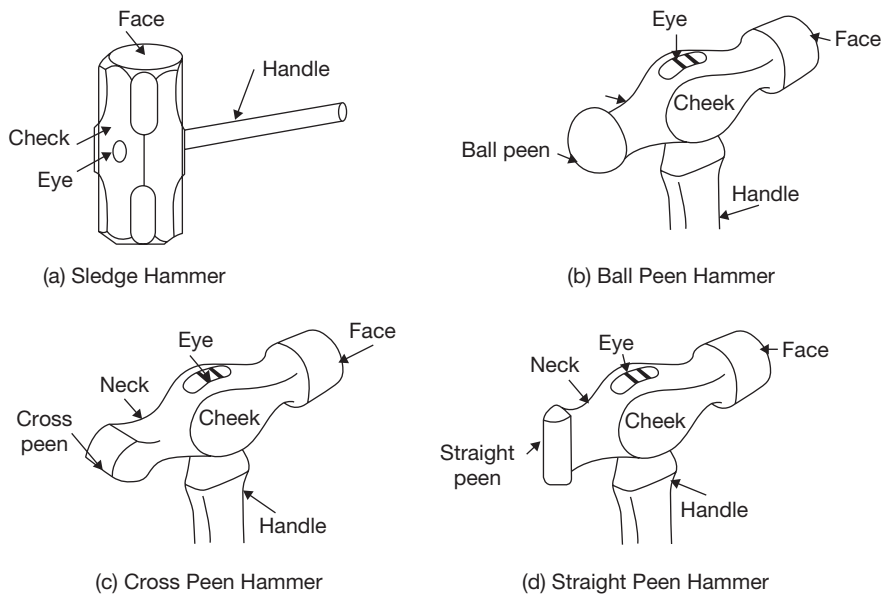
block. The flat projecting part of the back of the anvil is known as the tail. It carries a square hole to accommodate the square shank of the bottom part of various hand tools like swages, fuller. It is called a hardie hole. The circular hole provided near the hardie hole is known as pritchel hole. The top face of the anvil should stand at about 0.75 m from the floor. However, anvil may be of different weight and sizes depending on its applications.

### 21.27.3 Hammer

Hammers are used to blow the job by striking on it. The hammer is classified according to its shape and weight. The heavy hammer in a larger size is known as sledge hammer and used by a separate person, known as hammer man. The lighter in weight and small size hammers, i.e., Smith's hammers are also classified into ball peen hammer, cross peen hammer, and straight peen hammer. The different parts of the hammer are shown in the Figure 21.31.

In ball peen hammer, the shape of the peen is spherical; in cross peen hammer the shape of the peen is linear but perpendicular to the axis and in straight peen hammer, the peen is linear but parallel to the axis. All the hammers are mainly divided into four parts; namely peen, eye, cheeks, and face. The peen is the top part made slightly tapered from the cheeks and rounded at the top. Just below the peen, the part is known as the neck. The face is hardened and polished well and is given slight rounding along the circular edges so that the metal surface is not spoiled by the sharp edges when the former is struck by the hammer. The eye is normally made oval or elliptical in shape and



**FIGURE 21.31**

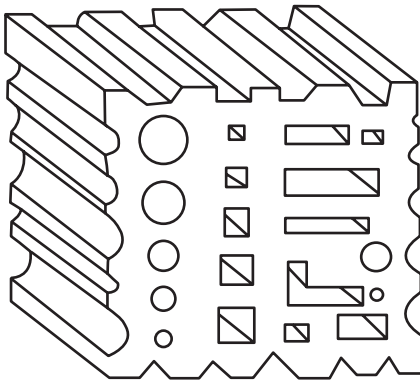
Sledge and Smith's Hammers

accommodates the handle. For small sized hammers these handles are made of wood or bamboo, but in the case of sledge hammers, the handles made of solid bamboos. An arrangement of the wedge is done in the handle so that slipping of the hammer off the handle during striking can be avoided. Sledge hammers are comparatively 3 to 4 times heavier than the hand hammers. They are available in varying sizes and weights from 3 to 8 kg. They are employed when heavy blows are needed in forging and other operations done on heavy jobs.

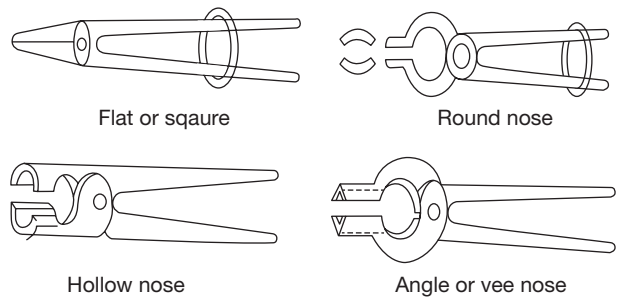
#### 21.27.4 Swage Block

Swage block is made of cast iron having a number of slots of different shapes and sizes along its four side faces and through holes from its top face to bottom face as shown in the Figure 21.32.

It is used as a support in punching holes and forming different shapes. The job to be given a required shape is kept on a similar shaped slot, which acts as a bottom swage, and then the top swage is applied on the other side of the job. Swages consist of two parts: the top part having handle and a bottom part having a square shank, which fits in the hardie hole in the anvil. The holes in the top and bottom face are used in punching. Their use prevents the punch from spoiling by striking against a hard surface after the hole has been punched.


**FIGURE 21.32**

Swage Block


**FIGURE 21.33**

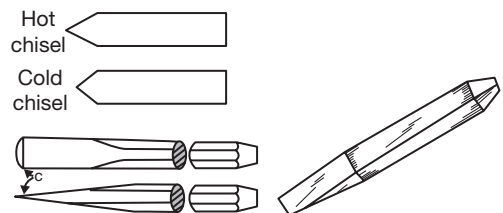
Tongs

### 21.27.5 Tongs

Tongs are used to hold the jobs in a specific position and turning over during forging. They are made of mild steel. Tongs are made of mild steel generally in two pieces, which are riveted together to form a hinge as shown in the Figure 21.33. Smaller length on one side of the hinge consists of the holding jaws, which are made of different shapes and sizes to hold the jobs of various shapes and sizes, and the longer portions on the other side of the hinge form the arms, which are held in hand by the smith to apply the pressure on the job through the jaws. Tongs may be made of different shapes and size to handle the different shapes of the jobs, but the commonly used lengths of the tongs in hand forging vary from 400 to 600 mm with the jaws' opening ranging from 6 to 55 mm. The nomenclature of the tongs is based on the shapes of the jaws, e.g., flat or square tong, round tong, hollow nose tong, the angle of vee nose tong, etc.

### 21.27.6 Chisels

Chisels are used to cut metals in the hot or cold state. The chisels which are used for cutting the metal in hot state are termed as hot chisels and the others used for cutting in cold state are known as cold chisels as shown in the Figure 21.34. A cold chisel carries an included angle of  $60^\circ$  at the cutting edge and the latter is well hardened and tempered. It is made of high carbon steel. A hot chisel can be made of medium

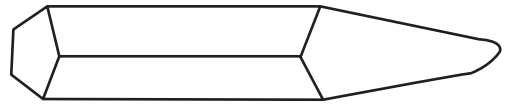

**FIGURE 21.34**

Chisel

carbon steel as there is no need of hardening. It is used to cut the metal in a plastic state. The included angle of its cutting edge is  $30^\circ$ .

### 21.27.7 Punches

Punches are used to produce holes in red hot jobs as shown in the Figure 21.35. They are tapered tools made in various shapes and sizes. A larger tapered punch is called a drift. The job is placed on the anvil and the punch is hammered through it up to about half its depth. It is then turned over and the punch made to pass through it. Completion of this operation in two stages prevents the job from splitting and full to bursting.

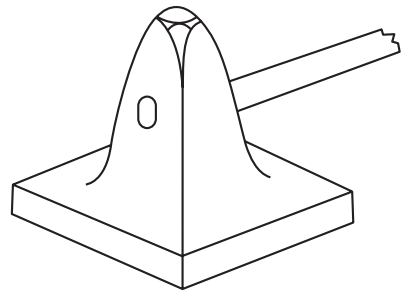


**FIGURE 21.35**

Punch

### 21.27.8 Flatters

Flatters are made of high carbon steel. They are used to give smoothness and accuracy to articles, which have already been shaped by fullers and swages. These are also known as smoothers. They consist of a square body, fitted with a handle, and a flat square bottom as shown in the Figure 21.36. They are used for leveling and finishing a flat surface after drawing out or any other forging operation.



**FIGURE 21.36**

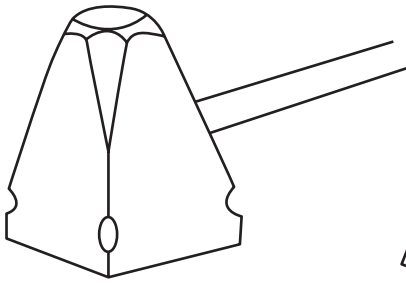
Flatter

### 21.27.9 Set Hammer

Set hammer is used to finish the corners of the jobs, formed by two adjacent surfaces at right angles as shown in the Figure 21.37. The job is supported on the anvil and the tool is hammered from the top. It is a type of hammer, but not used for hammering or blowing purposes. It is made of tool steel and hardened. Its construction is also similar to that of a flatter but is smaller in size and it does not carry an enlarged bottom face.

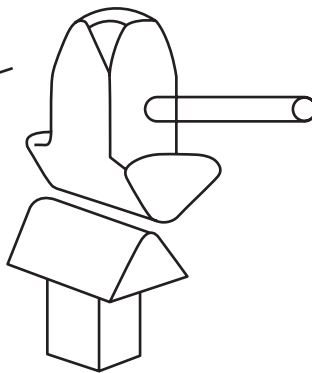
### 21.27.10 Fullers

Fullers are used to produce a neck in the jobs. They are made in the top and bottom tools as shown in the Figure 21.38. Fullers are made in various shapes and sizes according to needs, the size denoting the width of the fuller. These tools are made of high carbon steel in different sizes to suit the various types of jobs. They are generally used in pairs, consisting of a top and bottom filler. Their working edges are normally rounded.



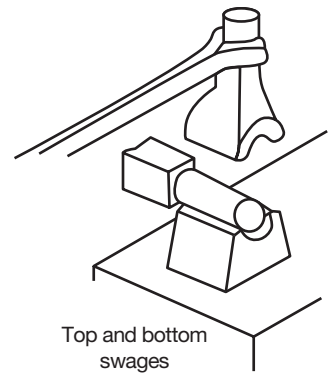
**FIGURE 21.37**

Set Hammer



**FIGURE 21.38**

Fullers



**FIGURE 21.39**

Swages

### 21.27.11 Swages

Swages are very similar to fullers made of high steel in two parts called the top and bottom swage, but their faces carry circular grooves to suit the size of the work as shown in the Figure 21.39. The top swage carries a handle and the bottom swage carries a square shank, which is fitted in the hardie hole of the anvil during the operation.

## RECAP ZONE .....



### Points to Remember

- **Mechanical working** is a process of shaping of metals by plastic deformation.
- When metal is deformed between room temperature and recrystallization temperature, it is called **cold working**.
- When metal is deformed between recrystallization temperature and a melting point of the metal, it is called **hot working**.
- The **recrystallization temperature** is defined as “the approximate minimum temperature at which the complete recrystallization of cold worked metal occurs within a specified period of time.
- **Rolling** is the process of reducing the thickness or changing the cross-sectional area of the workpiece by means of rolling mills.
- **Forging** is a process of plastic deformation for shaping. The force applied in this case is an intermittently compressive force while in a rolling process force applied is a continuous compressive force.
- In **open die forging**, the hot workpiece is placed between two flat dies and is hammered to produce the desired shape.
- In **impression-die forging** the heated workpiece is placed between two required shaped die and is pressed or hammered.

- **Closed die-forging** is a variation of impression-die forging without flash.
- In **drop forging**, the metal is deformed by the impact of a hammer or die and hot metal is forced to conform the die shape.
- **Press forging** employs a slow squeezing action produced by mechanically or hydraulically operated press as compared to rapid impact blows of hammer in drop forging.
- **Upset forging** is used to produce head in a bolt, screw, bar, etc. Only a certain portion of the material is deformed and rest is unaffected from the deformation.
- **Extrusion** is a primary shaping process in which a metal kept in a cylinder is forced to pass through the opening of a die.
- **Wire drawing** is a process to produce a small diameter wire from billet by applying tensile force.
- An important difference between the bar drawing and wire drawing is that the bars must remain straight. The length of the bar which can be drawn is limited by the maximum travel of the carriage, which may be from 50 to 100 feet.
- Like bar drawing, tube drawing is accomplished in most cases with the use of draw bench.
- If the rate of energy flow for forming is high, it is known as high energy rate forming. Energy used may be chemical, magnetic, and electro discharge, etc.
- In **thread rolling** there is no chips formation, i.e., the threads are produced by plastic deformation.
- **Sheet metal** is thin and flat pieces of metals. It is one of the fundamental forms used in metalworking and can be cut and bent into a variety of different shapes.
- **Punching** is a process of producing a hole in a flat sheet while blanking is a process of cut out an intricate shape from the sheet which is known as blank.
- In a stretch forming operation, a sheet metal is stretched to yield point in tension and then wrapped over and around the form block (die).
- **Deep drawing** or drawing is defined as a process of making the cup-shaped parts from flat sheet metal blanks.
- **Powder metallurgy** is a process of making components from metallic powders.
- **Smithy** is a workplace where metal is worked with heating and hammering.
- A smithy's work is concerned with the heating of a metal stock to a desired temperature and enables it to obtain sufficient plasticity so that it can be given a desired shape by the operations like hammering, bending, pressing, etc.
- **Anvil** is a type of rigid support to the job to be forged or hammered.
- **Hammers** are used to blow the job by striking on it. The hammer is classified according to its shape and weight.
- **Swage block** is used as a support in punching holes and forming different shapes.
- **Tongs** are used to hold the jobs in a specific position and turning over during forging.
- **Chisels** are used to cut metals in the hot or cold state.
- **Punches** are used to produce holes in red hot jobs.
- **Fullers** are used to give smoothness and accuracy to articles, which have already been shaped by fullers and swages.
- **Set hammer** is used to finish the corners of the jobs, formed by two adjacent surfaces at right angles.
- **Fullers** are used to produce a neck in the jobs.
- **Swages** are very similar to fullers made of high steel in two parts called the top and bottom swage, but their faces carry circular grooves to suit the size of the work.



## REVIEW ZONE

### Multiple-choice Questions

- The important property of a material in all metal forming process is:
  - Elasticity
  - Plasticity
  - Ductility
  - Brittleness
- Which of the following material cannot be forged:
  - Wrought iron
  - Cast iron
  - Mild steel
  - High carbon steel
- Mechanical properties of the metal improve in hot working due to:
  - Recovery of grains
  - Recrystallization
  - Grain growth
  - Refinement of grain size
- The increase in hardness due to cold working is called:
  - Cold hardening
  - Hot hardening
  - Strain hardening
  - Age hardening
- The extruded product moves in the backward direction opposite to that of the deforming force in:
  - Forward extrusion
  - Die extrusion
  - Backward extrusion
  - Wire drawing
- Hot working operations are carried at:
  - Recrystallization temperature
  - Below crystallization temperature
  - Above crystallization temperature
  - Above room temperature
- Seamless tubes are made by:
  - Piercing
  - Extrusion
  - Rolling
  - Plug rolling
- The operation of removing the burr or flash from the forged parts in drop forging is known as:
  - Lancing
  - Coining
  - Trimming
  - Shot peening
- In four high rolls mill, the bigger roll is called:
  - Guide rolls
  - Back up rolls
  - Main rolls
  - Support rolls
- Large size bolt heads are made by:
  - Swaging
  - Roll forging
  - Tumbling
  - Upset forging
- Symmetrical hollow parts of circular cross section are made by hot:
  - Forging
  - Extrusion
  - Piercing
  - Spinning
- In drawing operation, the metal flows due to:
  - Ductility
  - Work hardening
  - Plasticity
  - Shearing
- Hemming is the operation:
  - In which the edges of the sheet are turned over to provide stiffness and a smooth edge.
  - Of producing contours in sheet metal and bending previously roll formed sections.
  - Employed to expand a tubular or cylindrical part.
  - None of these

### Fill in the Blanks

- If the rate of energy flow for forming is high, it is known as \_\_\_\_\_.
- \_\_\_\_\_ is defined as process for the making of cup shaped parts from flat sheet metal blanks.
- Punching is a process of producing \_\_\_\_\_ in a flat sheet.
- Powder metallurgy is a process of making components from \_\_\_\_\_.
- When metal is deformed between recrystallization temperature and melting point of the metal, it is called \_\_\_\_\_.
- When metal is deformed between room temperature and recrystallization temperature, it is called \_\_\_\_\_.
- \_\_\_\_\_ is a process to produce a small diameter wire from billet by applying tensile force.

## Answers

- |          |                              |                 |                  |                  |         |
|----------|------------------------------|-----------------|------------------|------------------|---------|
| 1. (b)   | 2. (b)                       | 3. (d)          | 4. (c)           | 5. (c)           | 6. (c)  |
| 7. (a)   | 8. (c)                       | 9. (b)          | 10. (d)          | 11. (d)          | 12. (c) |
| 13. (a)  | 14. high energy rate forming |                 | 15. Deep drawing |                  |         |
| 16. hole | 17. metal powder             | 18. hot working | 19. cold working | 20. Wire drawing |         |

## Theory Questions

1. What do you mean by mechanical working? Differentiate between hot working and cold working.
2. What is forging? Explain different forging process.
3. Explain the various forging defects and its remedies.
4. Explain the rolling process and the defects occurred in rolling.
5. Differentiate between backward and forward extrusions.
6. Write notes on high energy rate forming.
7. Explain the process of tube drawing.
8. What is the basic difference between bar drawing and wire drawing?
9. What do you mean by stretch forming?
10. Write the name and applications of different hand tools used in sheet metals.
11. What are the various sheet metal operations?
12. Differentiate between punching and blanking.
13. Explain the process of deep drawing.
14. Explain the process to manufacture internal and external threads using forming process.
15. What is powder metallurgy? Explain the various steps used in powder metallurgy.
16. Explain the methods to produce metal powders.
17. Explain the advantages, disadvantages, and applications of powder metallurgy.
18. What do you mean by smithy?
19. Write short notes on: (i) Hearth, (ii) Anvil, (iii) Set hammers, (iv) Swage blocks, (v) Fullers, (vi) Flatters, and (vii) Swages.

# Manufacturing Systems: NC, CNC, DNC, and Robotics

## Learning Objectives

*By the end of this chapter, the student will be able:*

- To understand the manufacturing systems
- To demonstrate the computer integrated systems
- To describe the numerical control, computer numerical control, and direct numerical control of manufacturing systems
- To describe the automation of production systems
- To understand the basic concepts of robotics

### 22.1 ► INTRODUCTION

A Manufacturing system consists of all the resources required to transform the material from its raw form to finished form. The resources involved in this transformation process may be Man, materials, money, machine, management, energy, etc. A manufacturing system's components may be broadly categorized as:

- (a) Production machines, tools, jigs, fixtures, etc.
- (b) Material handling systems.
- (c) Computer systems.
- (d) Human resources.

#### 22.1.1 Production Machines, Tools, Fixtures, and Other Related Hardware

In manufacturing systems, the term workstation refers to a location in the factory where some well-defined operation is accomplished by men or/and machines.



The machines used in manufacturing or assembly can be classified as:

- ▶ Manually operated machines
- ▶ Semi-automated machines
- ▶ Fully automated machines

**Manually Operated Machines:** In manually operated machines, the machines only provide the power for operations but the control of operations is total with operators. An operator is required to be at machine continuously during operation.

**Semi-automated:** A semi-automated machine performs a portion of the work cycle under some form of program/automated control, and a worker tends to the machine for the remainder of the cycle. Typical worker tasks include loading and unloading parts.

**Fully Automated:** A fully-automated machine operates for extended periods (longer than one work cycle) without the involvement of worker in the operations.

### 22.1.2 Material Handling System

The main objectives of a material handling system are to load the job at each workstation, position the job at each workstation, unload the job at each workstation, transport the job between stations in multi-station manufacturing systems, and store the finished jobs into the storage.

### 22.1.3 Computer Systems

A computer system is required to control the functions of the machines and to participate in the overall coordination and management of the manufacturing system. The objectives of a computer system are to give instructions to workers, transform part programs to machine language, control material handling system, schedule production, monitor safety measures, control the quality of job to be produced, etc.

### 22.1.4 Human Workers

Two types of labors are involved in a manufacturing system: direct labors and indirect labors. Direct labors perform some or all of the value-added work that is accomplished on the job. They directly add to the value to the job by performing manual work on it or by controlling the machines that perform the work. While indirect labors manage or support manufacturing activities without direct involvement in job processing. All the administrators, marketing personals, financial managers, human resource managers are indirect labors.

## 22.2 ▶ AUTOMATION

Automation is the technology by which a process or procedure is accomplished without human assistance. An automated system consists of Power—to accomplish the process and

operate the automated system, Program of instructions—to direct the process, and Control system—to actuate the instructions.

Automation of production systems can be classified into three categories:

- (a) Fixed automation (Rigid Automation).
- (b) Programmable automation (Soft Automation).
- (c) Flexible automation.

**22.2.1 Fixed Automation (Rigid Automation):** Fixed automation is devoted to the production of a specific type of the item. It cannot be used to accommodate the production of a new type of the products. Therefore, it is also known as rigid or hard automation. It is mostly used for mass production or continuous types of production. The sequence of operations is automated as per the requirement of production of that specific item. This is called hard automation.

#### *Advantages of the fixed automation*

- ▶ Low unit cost of production.
- ▶ Automated material handling.
- ▶ High production rate.
- ▶ Suitable for mass/continuous production

#### *Disadvantages of the fixed automation*

- ▶ High initial Investment cost.
- ▶ Relatively inflexible in accommodating the product changes.

**22.2.2 Programmable Automation:** In programmable automation, the production equipment is designed with the capability to change the sequence of operations to accommodate different product configurations. The operation sequence is controlled by a program, which is a set of instructions coded. So that they can be read and interpreted by the system. New programs can be prepared and entered into the equipment to produce new products.

#### *Advantages of the programmable automation*

- ▶ Flexible to deal with design variations.
- ▶ Suitable for batch production.

#### *Disadvantages of the programmable automation*

- ▶ High investment in general purpose equipment.
- ▶ Lower production rate than fixed automation.

**22.2.3 Flexible Automation:** (Soft Automation): Flexible automation is an extension of programmable automation. A flexible automation system is capable of producing a variety of parts with virtually no time lost for changeovers from one part style to the next. There is no loss of production time while reprogramming the system and altering the physical set up.

### *Advantages of the Flexible automation*

- ▶ Continuous production of variable mixtures of the product.
- ▶ Flexible to deal with product design variation.

### *Disadvantages of the flexible automation*

- ▶ Medium production rate
- ▶ High investment.
- ▶ High unit cost relative to fixed automation.

## **22.3 ▶ COMPUTER INTEGRATED MANUFACTURING (CIM)**

In a computer integrated manufacturing system, all the manufacturing and business functions are integrated through computer networking. Manufacturing functions include CAD/CAM and business functions include all other activities in the organization like demand management, material management, purchasing, sales, and marketing, etc.

## **22.4 ▶ CAD/CAM**

CAD/CAM involves the use of the computer to accomplish certain functions in design and manufacturing. CAD is concerned with the use of the computer to support the design engineering functions and CAM is concerned with the computer to support manufacturing engineering functions. The combination of CAD and CAM in the symbolic form is represented as CAD/CAM to integrate design and manufacturing functions in a firm.

### **22.4.1 Computer Aided Design (CAD)**

CAD can be defined as any design activity that involves the effective use of a computer to create, modify and document an engineering design. There are 4-phases of CAD:

- ▶ Synthesis (Geometric modeling).
- ▶ Analysis and Optimization (Engineering analysis).
- ▶ Evaluation (Design review and evaluation).
- ▶ Presentation (Automated drafting).

Geometric modeling is concerned with the mathematical description of the geometry of an object. The mathematical description called a model is contained in computer memory. The image is displayed on graphics terminal to perform certain operations on the model. There are various types of geometric models in CAD: wire frame and solid models, colored and animation, two-dimensional and three-dimensional.

The second phase is engineering analysis, which includes the stress-strain calculations, heat transfer analysis, dynamic simulation, and optimization. The CAD system increases the designer's analysis ability.

The third phase is design evaluation and review procedures. Some CAD features which are helpful evaluating and reviewing a proposed design include:

- (a) Automatic dimensioning routines.
- (b) Interference checking routines.
- (c) Kinematics routines.

The fourth phase, where CAD is useful in the design process, is the presentation and documentation. CAD system can be used as automated drafting machines to prepare highly accurate engineering drawing quickly. It is estimated that a CAD system increases productivity in the drafting function by 5-times the manual preparation of the drawing.

**Objectives of CAD System:** The objectives of CAD system are to increase the productivity of the designer, improve the quality of the design, improve the design documentation, create manufacturing database.

### 22.4.2 Computer Aided Manufacturing (CAM)

CAM is mainly used for manufacturing planning and manufacturing control. In the manufacturing planning, the computer is used indirectly to provide information for the effective planning and management of production activities. The computer is used for following planning activities:

- (a) Cost estimating.
- (b) Computer aided process planning.
- (c) Computer-assisted NC part programming.
- (d) Development of work standards.
- (e) Computer aided line balancing.
- (f) Production and inventory planning.

Manufacturing control is concerned with managing and controlling the physical operations in the factory to implement the manufacturing plans. Mainly three types of controls are required in manufacturing:

**Shop Floor Control:** It is concerned with the problem of monitoring the progress of processing, assembling, and inspection of the products in the factory.

**Inventory Control:** It is concerned with the demand fulfillment and also to reduce the inventory to eliminate the wastage and extra money investment. Thus, the optimum inventory size is maintained based on accurate demand forecasting.

**Quality Control:** the purpose of the quality control is to assure that the quality of the product and its components meet the standards specified by the product designer. To accomplish its

mission, quality control depends on the inspection activities performed in the factory at various times throughout the manufacture of the product.

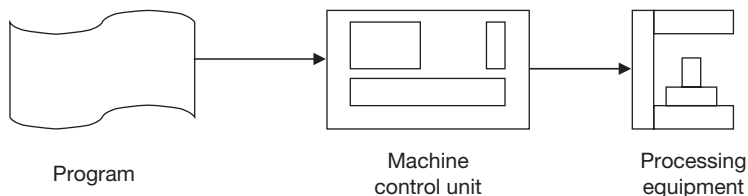
## 22.5 ► NUMERICAL CONTROL (NC)

Numerical control can be defined as a form of programmable automation in which the machining process is controlled by numbers, letters, and symbols. NC technology has been applied for wide variety of operations but the principal application is in machining operations.

An operational NC system consists of the following three basic components:

- (a) Program of instruction.
- (b) Controller unit.
- (c) Machine tools.

The program of instruction consists of details of the sequence of operations in the symbolic, numeric, or alphanumeric form on some medium like tape, which can be interpreted by the controller unit. Controller unit consists of the electronics and hardware that read and interpret the program of instructions and convert it into mechanical actions of the machine tool. The typical elements of conventional NC controller unit include the tape reader, a data buffer, signal output channels to the machine tool, feedback channels from the machine tool, and the sequence control to coordinate the overall operation of the forging element. The machine tool is the part of NC system which performs useful work. It also includes the cutting tools, work fixtures and other auxiliary equipment needed in the machining operation. The three components of NC system is shown in Figure 22.1.



**FIGURE 22.1**

NC Components

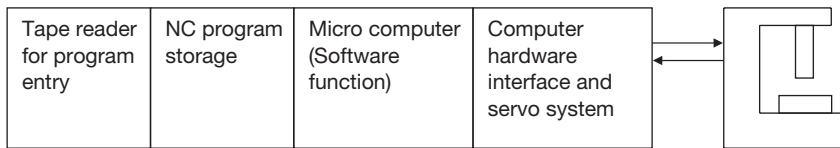
### 22.5.1 Limitations/Drawback of Conventional NC System

- Part programming mistakes in punched tape are common.
- Short life of punch tape due to wear and tear.
- Less reliable tape reader component.

- ▶ Less flexible hard wired controller unit.
- ▶ Non-optimal speed and feed.

## 22.6 ▶ COMPUTER NUMERICAL CONTROL (CNC)

The appearance of CNC system is very similar to NC system but the way of using the program is different. In a conventional NC system, the punched tape is cycled through the tape reader for each work part in the batch. The machine control unit reads in a block of instructions on the tape, executing that block before proceeding to the next block. In CNC, the entire program is entered once and stored in computer memory. The machining cycle for each part is controlled by the program contained in memory rather than on the tape itself. The general configuration of CNC system is shown in Figure 22.2.



**FIGURE 22.2**

Components of CNC Systems

Following features are associated with CNC system:

- ▶ Storage of more than one program.
- ▶ Use of floppy/discs.
- ▶ Program editing at the machine tool site.
- ▶ Fixed cycles and programming subroutines.
- ▶ Interpolation.
- ▶ Positioning features for setup.
- ▶ Cutter length compensation.
- ▶ Diagnostics.
- ▶ Communication Interface.

## 22.7 ▶ PROGRAMMING METHODS

CNC part programming may be accomplished in different ways, such as:

**Manual Part Programming:** Manual part programming is the oldest method and still quite popular. This technique requires the programmer to examine a part drawing then “manually” calculate all tool paths. This information is recorded on a manuscript. A punched tape is prepared from the manuscript.

**Computer Assisted Part Programming:** In computer assisted part programming, much of the tedious work required to calculate tool offsets, partial arcs, and the geometry of the part, is performed by the computer. When using computer assisted part programming, the programmer utilizes a high-level language to describe part geometry and cutter path with respect to the geometry, then the computer performs all necessary calculations and generates tool path information. This tool path data is then post-processed into the format required for a specific CNC machine tool. For complex parts, computer assisted part programming may be necessary and the savings in programming time can be substantial.

**Computer Aided Drafting/Computer Aided Manufacturing:** This method of programming machine tools is sophisticated and growing in popularity. As CAD/CAM software systems become more users friendly, inexpensive, and reliable, more and more manufacturers are turning to CAD/CAM for part programming. Essentially, CAD/CAM enables a programmer to manipulate CAD data so CAM software is capable of understanding the data. Once properly manipulated, the CAM software performs all necessary calculations and generates CNC tool path data that made be post-processed for a variety of machine tools.

**Conversational and Shop Floor Programming:** Conversational programming is an interactive method of generating CNC code. The CNC programmer or machine tool operator answers questions and provides data about tool paths when prompted by a conversational programming software system. These answers to questions and associated data are translated into a CNC program for a particular machine tool. Often these conversational systems reside on the machine tool controller and the interaction (programming) is done on the shop floor—hence the term shop floor programming. This method of programming is generally restricted to relatively simple geometry.

**Parametric Programming:** An enhancement to the methods above more so than a method in and of itself, parametric programming software systems enables the programmer to describe part geometry using variables. Once described, entering specific values for the variables that uniquely identify the part generates an actual tool path CNC program.

### **Advantages**

- ▶ The part program tape and tape reader are used only once to enter the program into the memory.
- ▶ Tape can be edited at the machine site.
- ▶ Greater flexibility.
- ▶ Metric conversion.
- ▶ Compatible with total manufacturing information system.

## 22.8 ► COMPARISON OF NC AND CNC MACHINES

NC machines offered a reliable way of producing machine parts using pre-programmed commands. These commands consisted of alphanumeric characters defined by the RS232 IEEE code. These characters were coded on punch paper tape in formats specifically planned for a certain machine tool. These programs (punched tape) would then be read into the NC control using a paper tape reader. If during testing a program error were detected, the paper tape would have to be edited. This process meant duplicating a tape up to the incorrect character(s), retyping the correct characters, and then continuing with the duplication process. This is a time-consuming process. During the running of NC programs, if a tool would begin to wear causing part dimensions to approach tolerance limits, the operator would have to stop and adjust the tool(s) to compensate for this wear.

In CNC machines, data for the control are still coded using either RS232 or the newer, more acceptable RSxyz ASCII code (American Standard Code for Information Interchange). Entire CNC programs may be loaded into the memory of the CNC control enabling the programmer or machine operator to edit the programs at the machine. If program changes are required, many CNC machines have built-in paper tape punch machines that allow for the generation of a new tape at the control. Tool wear is handled by adjusting program data in memory or calling in from a tool register one of several pre-programmed tool offsets.

As the implementation of microprocessors expanded, OEM's of NC/CNC machines began using them in the construction of controls. By the late 1970's, nearly all NC/CNC manufacturers were using microprocessors (computers) in their controls. Today the phrase NC is commonly used when referring to CNC machines because of the need to differentiate the two no longer exists. Today, ALL modern NC machines are in fact CNC machines. Throughout the chapter, we will use the phrase NC machines to refer to both NC and CNC unless specifically noted otherwise.

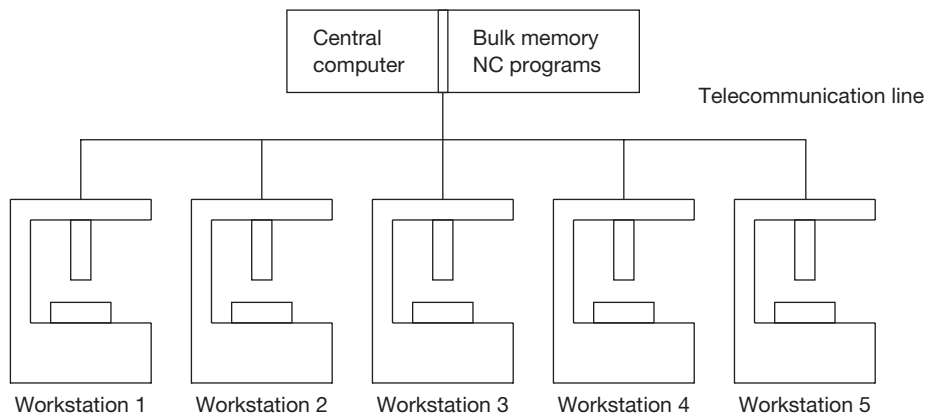
## 22.9 ► DIRECT NUMERICAL CONTROL (DNC)

Direct numerical control (DNC) can be defined as a manufacturing system in which a number of machines are controlled by a computer through direct connection and in real time. The tape reader is omitted in DNC, thus relieving the system of its least reliable component. Instead of using the tape reader, the part program is transmitted to the machine tool directly from the computer memory. In principle, one computer can be used to control up to 256 machine tool. When the machine needs control commands, they are communicated to it immediately.

The system consists of following four components as shown in Figure 22.3.

1. Central computer.
2. Bulk memory, storage of NC part programs.
3. Telecommunication lines.
4. Machine tools.



**FIGURE 22.3**

General Configuration of DNC

### *Advantages*

Time-saving due to the control of more than one machine by a single computer.

- ▶ Greater computational capability for such functions as circular interpolation.
- ▶ Remote computer location is safe environment.
- ▶ Elimination of tapes and tape reader at the machine for improved reliability.
- ▶ Elimination of hardware controller unit on some systems.
- ▶ Programs stored as cutter location data can be post-processed for whatever suitable machine is assigned to process the job.

## ROBOTICS

### 22.10 ► INTRODUCTION

Robotics is a part of the automation, which deals with the working, design, and application of robots. An industrial robot is a general purpose and programmable machine, which is used to perform the various task in the industry.

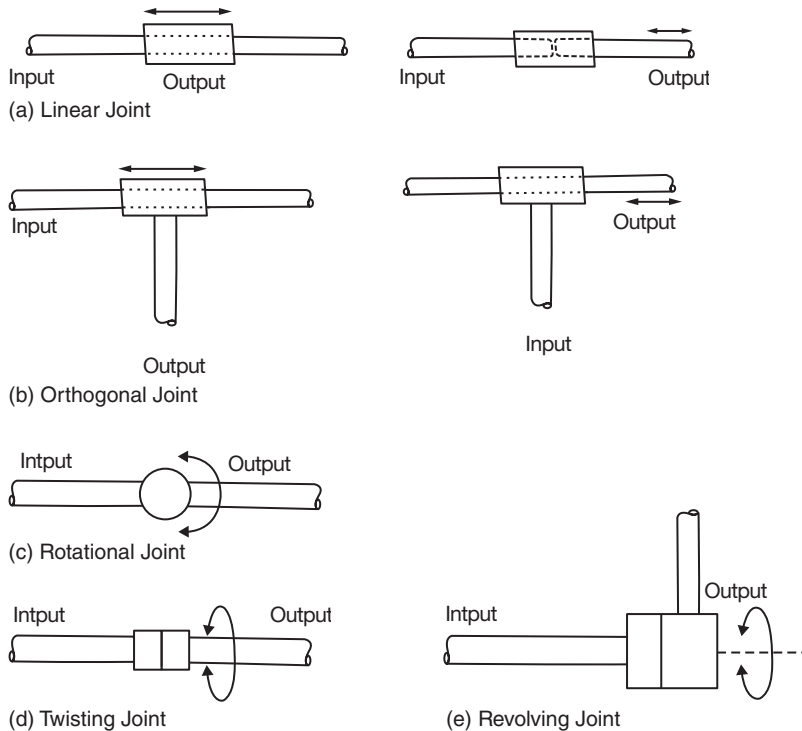
The definition of an industrial robot given by the Robotic Industries Association (RIA) as: “An industrial robot is a reprogrammable, multifunctional manipulator designed to move materials, parts, tools, or special devices through variable programmed motions for the performance of a variety of tasks.”

## 22.11 ► ROBOT ANATOMY

Robot anatomy deals with the types and sizes of the joints and links and other aspects of the manipulator's physical construction.

**Joints and Links:** The joints used in an industrial robot are very similar to the joints in a human body; it provides relative motion between two parts of the body. Each joint provides the robot with a degree of freedom (d.o.f.) of the motion. In nearly all cases, only one d.o.f. is associated with a joint. Two links are connected to each joint, one which we call the input link and another is called the output link. Nearly all industrial robots have mechanical joints that can be classified into one of five types.

1. *Linear Joint:* In this joint, the relative movement between the input link and the output link is a linear sliding motion, with the axes of the two links being parallel. We refer to this as type *L*-joint as shown in Figure 22.4 (a).
2. *Orthogonal Joint:* This is also a linear sliding motion, but the input and output links are perpendicular to each other during the movement. This is a type *O*-joint as shown in Figure 22.4 (b).



**FIGURE 22.4**

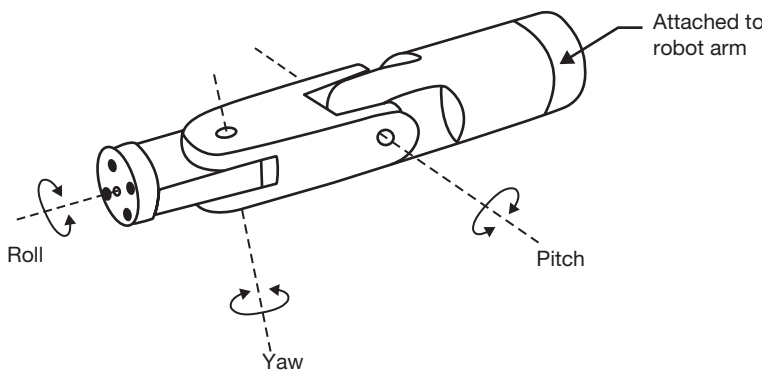
Robotic Joints

3. *Rotational Joint*: This type of joint provides a rotational relative motion of the joints, with the axes of the input and output link. This is a type *R*-joint as shown in Figure 22.4 (c).
4. *Twisting Joint*: This joint also involves a rotary motion, but the axis of rotation is parallel to the axes of the two links. We called this as type-*T* joint as shown in Figure 22.4 (d).
5. *Revolving Joint*: In this type of joint, the axis of the input link is parallel to the axis of rotation of the joint, and the axis of the output link is perpendicular to the axis of rotation. We refer to this as a type *V*-joint as shown in Figure 22.4 (e).

## 22.12 ► THREE DEGREE OF FREEDOM FOR ROBOT'S WRIST

To establish the orientation of the object, we can define three-degree of freedom for the robot's wrist as shown in Figure 22.5.

1. *Roll*: This degree of freedom (d.o.f.) can be accomplished by a *T*-type joint to rotate the object about the arm axis.
2. *Pitch*: This involves the up and down rotation of the object, typically done by means of a type *R*-joint.
3. *Yaw*: This involves right-to-left rotation of the object, also accomplished typically using an *R*-type joint.



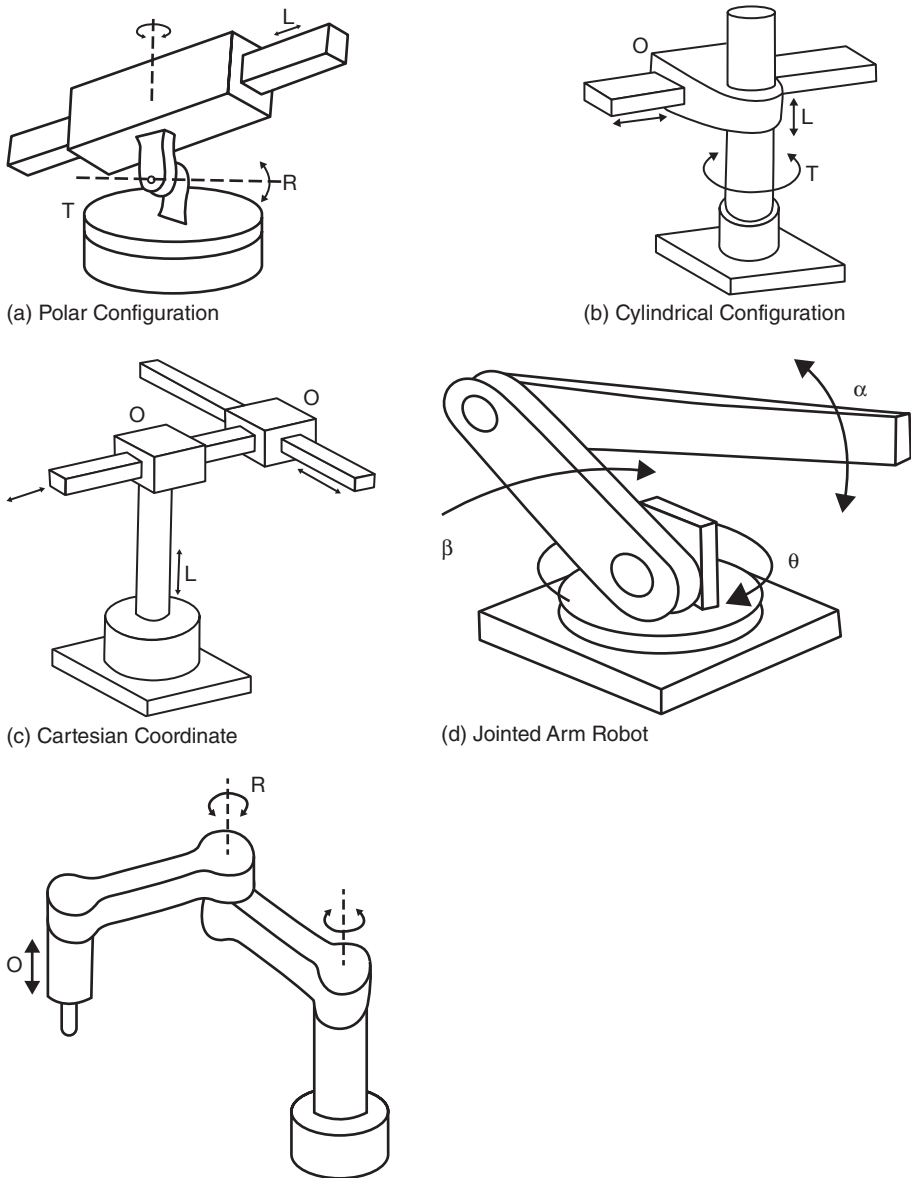
**FIGURE 22.5**

Three Degree Freedoms for Robotic Arm

## 22.13 ► ROBOT CONFIGURATIONS

There are five types of robot configurations as shown in Figure 22.6.

1. *Polar Configuration*: This configuration has a TRL notation. A sliding arm is actuated relative to the body, which can rotate about both a vertical axis (type *T*-joint) and horizontal axis (type *R*-joint).



(e) SCARA Robot

**FIGURE 22.6**

Robot Configurations

2. *Cylindrical Configuration*: This robot configuration consists of a vertical column, relative to which an arm assembly can be moved up and down. The end-of-arm can be moved in and out relative to the axis of the column. This configuration can be realized structurally in several ways. Example TLO, LVL.

3. *Cartesian Coordinate Robot*: Other names for this configuration include rectilinear robot and x-y-z robot. It is composed of three sliding joints two of which are orthogonal. The sketch in the shows a LOO rotation. Another possible rotation is OLO.
4. *Jointed-arm-robot*: This robot has a human arm. Its arm has a shoulder joint and an elbow joint and the arm can be swiveled about the base. Possible configurations for this type include TRR and VVR type.
5. *SCARA* (Selective Compliance Assembly Robot Arm). This is similar to the jointed arm robot except that the shoulder and elbow rotational axes are vertical but compliant in the horizontal direction.

## 22.14 ► ROBOT CONTROL

The actuators are used to move the joint powered by a particular form of the drive system. Common drive system makes used in robotics are an electric drive, hydraulic drive, and pneumatic drive. The pneumatic drive is reserved for smaller robots, which are used in simple material transfer applications. Both electric drive and hydraulic drive are used on more sophisticated industrial robots. Electric drive systems are becoming more prevalent in commercially available robots. Electric drive robots are relatively accurate as compared to hydraulically powered robots. By contrast, the advantages of the hydraulic drive include greater speed and strength.

### 22.14.1 Type of Robot Control

**Limited Sequence Robot**: This is the most elementary control type and can be utilized only for simple motion cycles, such as pick and place operations. Usually, it is implemented by setting limits or mechanical steps for each joint and sequencing and actuation of the joints to accomplish the cycle. Feedback loops are sometimes used to indicate that the particular joint actuation has been accomplished so that the next step in the sequencing can be initiated. However, there is no servo control to accomplish precise positioning of the joint. Many pneumatically driven robots are limited sequence robots.

**Playback Robot with a Point-to-point Control**: In this system, the controller has a memory for recording the sequence of motions in a given work cycle, and also the locations that are associated with each element of the motion cycle. These locations and their sequence are programmed into memory and subsequently played back during the operation. In PTP (Point-to-Point) control, the individual position of the robot arm is recorded into the memory. These positions are not limited to the mechanical stops set for each joint as in the case of limited sequence robots.

**Playback Robot with Continuous Path Control**: These robots have the same playback capability as the previous type; however the number of individual location that can be recorded

into memory is far greater than for point-to-point. The points constituting the motion cycle can be spaced very closely together, which permits the robot to accomplish a smooth continuous motion. In PTP, only the final location of the individual motion elements are controlled; the path taken by the arm to reach the final location is not controlled. In a continuous path motion, the movement of an arm and wrist is controlled during the motion. Servo control is used to maintain continuous control over the position and speed of the manipulator. A playback robot with continuous path control has the inherent capacity for PTP control as well.

**Intelligent Robots:** The characteristics that make a robot more intelligent include the capacity to interact with its environment, make decisions when things go wrong during the work cycle, and operate in response to advanced sensor inputs such as machine vision. In addition, these robots possess the playback capability for either PTP or continuous path control. These features require a relatively high level of computer control and advanced programming language in order to input the decision-making logic and other intelligence into memory.

## 22.15 ► CONTROL SYSTEMS

Control is an essential part of an automated manufacturing system. All the part of manufacturing system like material handling, numerical control, industrial robots, FMS require a strong control system for successful operation. Feedback control systems are widespread and frequently used everywhere. In the case of feedback control system, a sensor senses the actual output and is compared with the reference value and the output is adjusted accordingly. For example, current is supplied to an electric iron up to certain temperature and a control unit like the thermostat is used to break down the circuit if the temperature goes beyond the limit, again current is allowed to pass when the temperature falls down the limit.

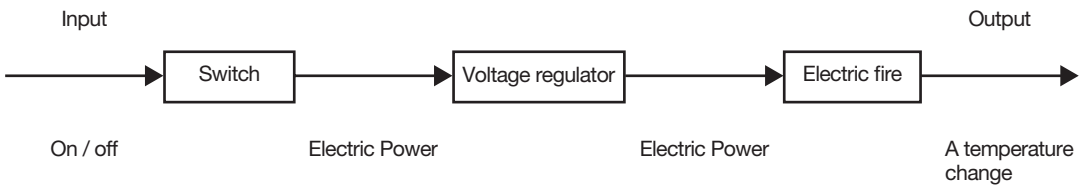
### 22.15.1 Basic Form of Control Systems

There are two basic forms of control system:

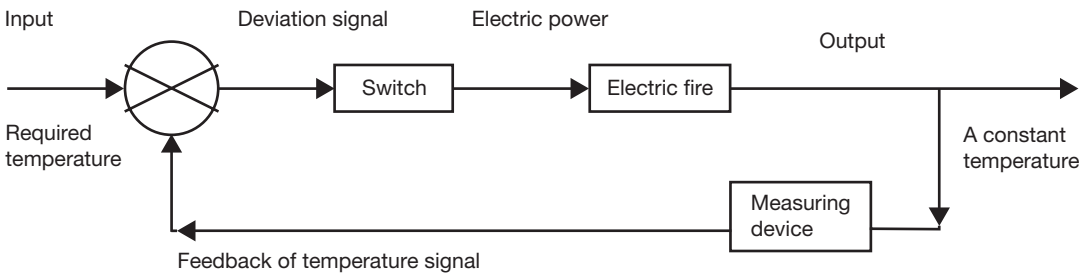
1. Open-loop control system.
2. Closed-loop control system.

In an open-loop control system, the output from the system has no effect on the input signal. But in a closed-loop control system, the output does have an effect on the input signal, modifying it to maintain an output signal at the required value.

Open-loop systems have the advantage of being relatively simple and consequently low cost with good reliability. However, they are often inaccurate since there is no connection for error. Closed-loop systems have the advantage of being relatively accurate in matching the actual to the required values. They are however more complex and so more costly with a greater number of components. The open and closed-loop control system is shown in Figures 22.7 and 22.8.

**FIGURE 22.7**

Open-loop Control Systems

**FIGURE 22.8**

Closed-loop Control Systems

Basic elements of closed-loop systems:

1. **Comparison Element:** This element compares the measured value with reference value signal in which the error can be positive or negative.
2. **Control Element:** Control elements take corrective action on error signal found after comparison with reference value signal. The control plans may be hard-wired systems in which the control plan is permanently fixed by the way the elements are connected together or programmable systems where the control plan is stored in a memory unit and may be altered by reprogramming.
3. **Correction Element:** The correction element produces a change in the process to convert or change the controlled condition. An actuator is used for the element of a correction unit that provides the power to carry out the control action.
4. **Process Element:** The process is what is being controlled. It could be a room in a house with its humidity and temperature being controlled.
5. **Measurement Element:** The measurement element produces a signal related to the variable condition of the process that is being controlled. It might be, for example, a switch, which is switched on when a particular position is reached, or a thermocouple, which gives an e.m.f, related to the temperature.

### 22.15.2 Sequential Control

Sequential control is used when control is such that actions are strictly ordered in a time or event driven sequence. An electrical circuit with sets of relays could obtain such control or cam-operated switches, which are wired up in such a way as to give the required sequence. Such hard-wired circuits are now more likely to have been replaced by a microprocessor-controlled system, with the sequencing being controlled by means of a software program.

### 22.15.3 Microprocessor Based Controllers

Microprocessors are now rapidly replacing the mechanical cam-operated controllers and being used in general to carry out control functions. They have the great advantage that a greater variety of programs become feasible. In many systems, there might be just an embedded micro-controller, this being a microprocessor with memory all integrated on one chip, which has been specifically programmed for the task concerned. A more adaptable form is a programmable logic controller (PLC). This is a microprocessor based controller, which uses programmable memory to store instructions and to implement functions such as logic, sequence, timing counting and arithmetic to control events and can be readily reprogrammed for different tasks.

### 22.15.4 Sensors Used in Robotics

**Tactile Sensors:** These sensors are used to determine whether the contact is made between the sensor and another object. Tactile sensors can be divided into two types—touch sensors and force sensors. Touch sensors are those that indicate simply that contact has been made with the object. Force sensors are used to indicate the magnitude of the force with the object. This might be useful in gripper to determine the magnitude of the force being applied to grasp an object.

**Proximity Sensors:** These indicate when an object is close to the sensor. When this type of sensor is used to indicate the actual distance of the object, it is called a range sensor.

**Machine Vision and Optical Sensors:** Optical sensors such as photocells and other photometric can be utilized to detect the presence or absence of objects, and are often used for proximity detection. Machine vision is used in robotics for inspection, part identification, guidance, and other uses.

**Miscellaneous Sensors:** This category includes other types of sensors that might be used in robotics, including devices for measuring temperature, fluid pressure, fluid flow, electrical voltage, current, and various other physical properties.



### 22.15.5 Transducers used in Robotics

A transducer is a device that converts one type of physical quantity (e.g., temperature, force, velocity, flow rate) into another type (commonly electrical voltage). The reason for making the conversion is that the converted signal can be used or evaluated more conveniently. Transducers are often called sensors when they are used to measure the value of a physical quantity.

**Transducers are of Two Types:** Analog and digital. Analog transducers produce a continuous analog signal such as electrical voltage. The signal can be interpreted, as the value of the measured variable. To make the interpretation, a calibration procedure is required. The calibration of measuring device establishes the relationship between the variable that is to be measured and converted into an output signal (voltage).

Digital transducers are measuring devices that produce a digital output signal. The digital signal may be in the form of a set of parallel status bits or a series of pulses that can be counted. In either case, the digital signal represents the quantity to be measured. Digital transducers are finding increased utilization because of the ease with which they can be read when used as stand-alone measuring instruments, and because of their compatibility with the digital computer.

#### *Desirable Features of Sensors and Transducers*

Some of the important desirable features of sensors and transducers are mentioned below:

1. High accuracy.
2. High precision.
3. Wide operating range.
4. Speed of response.
5. Ease of calibration.
6. High reliability.
7. Low cost.

### 22.16 ► APPLICATIONS OF ROBOTS

A. Material handling applications.

- Machine loading.
- Machine unloading.
- Machine loading and unloading.

Machine loading and unloading include the processes: die casting, plastic molding, metal machining, forging, press working, and heat treating.

B. Processing Operations.

Spot welding, Continuous arc welding, spray painting, drilling, grinding, wire brushing, water jet cutting, laser cutting, and riveting.

C. Assembly and inspection.

## RECAP ZONE .....



### Points to Remember

- A **Manufacturing system** consists of all the resources required to transform the material from its raw form to finished form.
- The resources involved in this transformation process may be man, materials, money, machine, management, energy, etc.
- In manufacturing systems, the term workstation refers to a location in the factory where some well-defined operation is accomplished by men or/and machines.
- **Automation** is the technology by which a process or procedure is accomplished without human assistance.
- An automated system consists of Power - to accomplish the process and operate the automated system, Program of instructions – to direct the process, and Control system – to actuate the instructions.
- **Fixed automation** is devoted to the production of a specific type of the item.
- It cannot be used to accommodate the production of a new type of the products.
- In **programmable automation**, the production equipment is designed with the capability to change the sequence of operations to accommodate different product configurations.
- The operation sequence is controlled by a program, which is a set of instructions coded.
- **Flexible automation** is an extension of programmable automation.
- A flexible automation system is capable of producing a variety of parts with virtually no time lost for changeovers from one part style to the next.
- There is no loss of production time while reprogramming the system and altering the physical set up.
- A computer system is required to control the functions of the machines and to participate in the overall coordination and management of the manufacturing system.
- The objectives of a computer system are to give instructions to workers, transform part programs to machine language, control material handling system, schedule production, monitor safety measures, control the quality of job to be produced, etc.
- In a computer integrated manufacturing system, all the manufacturing and business functions are integrated through computer networking.
- **CAD/CAM** involves the use of the computer to accomplish certain functions in design and manufacturing.
- **CAD** is concerned with the use of the computer to support the design engineering functions and **CAM** is concerned with the computer to support manufacturing engineering functions.
- **CAM** is mainly used for manufacturing planning and manufacturing control.
- **Geometric modeling** is concerned with the mathematical description of the geometry of an object. The mathematical description called a model is contained in computer memory. The image is displayed on graphics terminal to perform certain operations on the model.
- Numerical control can be defined as a form of programmable automation in which the machining process is controlled by numbers, letters, and symbols. NC technology has been applied for wide variety of operations but the principal application is in machining operations.
- In **CNC**, the entire program is entered once and stored in computer memory. The machining cycle for each part is controlled by the program contained in memory rather than on the tape itself.
- **Direct numerical control (DNC)** can be defined as a manufacturing system in which a number of machines are controlled by a computer through direct connection and in real time.



## REVIEW ZONE .....

### Multiple-choice Questions

1. A Manufacturing system consists of:
  - (a) All the resources required to transform the material from its raw form to finished form.
  - (b) Purchasing and selling activities of products
  - (c) Marketing systems
  - (d) All of the above
2. The resources involved in this transformation process may be:
  - (a) Man and materials,
  - (b) Money and machine,
  - (c) Management and energy,
  - (d) All of the above
3. In manufacturing systems, the term workstation refers to a location in the factory where:
  - (a) Services are provided to customer
  - (b) Enquiry is provided
  - (c) Some well-defined operation is accomplished by men or/and machines
  - (d) All of the above
4. A computer system is required to:
  - (a) control the functions of the machines
  - (b) participate in the overall coordination and management of the manufacturing system
  - (c) Both (a) and (b)
  - (d) None of these
5. The objectives of a computer system is to:
  - (a) Give instructions to workers and transform part programs to machine language
  - (b) Control material handling system, schedule production, monitor safety measures
  - (c) Control the quality of job to be produced.
  - (d) All of the above
6. In a computer integrated manufacturing system, all the manufacturing and business functions are integrated through:
  - (a) Computer networking
  - (b) Manual network
  - (c) Electrical network
  - (d) None of these
7. CAD is concerned with the use of the computer to support:
  - (a) The design engineering functions and CAM is concerned with the computer to support manufacturing engineering functions.
  - (b) Marketing network
  - (c) Supplier network
  - (d) All of the above
8. Geometric modeling is concerned with:
  - (a) Mathematical description of the geometry of an object.
  - (b) The image is displayed on graphics terminal to perform certain operations on the model.
  - (c) Both (a) and (b)
  - (d) None of these
9. Numerical control can be defined as a form of programmable automation in which the machining process is controlled by:
  - (a) Numbers
  - (b) Letters and symbols
  - (c) Both (a) and (b)
  - (d) None of these
10. An operational NC system consists of:
  - (a) Program of instruction.
  - (b) Controller unit
  - (c) Machine tools
  - (d) All of the above

### Answers

- |        |        |        |         |        |        |
|--------|--------|--------|---------|--------|--------|
| 1. (a) | 2. (d) | 3. (c) | 4. (c)  | 5. (d) | 6. (a) |
| 7. (a) | 8. (c) | 9. (c) | 10. (d) |        |        |

## Theory Questions

---

1. What is manufacturing system? Explain it.
2. Write notes on computer integrated manufacturing system and CAD/CAM.
3. Explain all the four phases of computer aided design.
4. Explain the activities involved in computer-aided manufacturing.
5. What is NC machine? Explain its applications and limitations.
6. Explain all features of CNC machine.
7. Explain the programming methods used in CNC machine. Also, mention the advantages of CNC machine over NC machine.
8. Write notes on DNC machine. How does it differ from CNC?
- \*9. Discuss CNC with its different components?
- \*10. Draw a neat diagram showing the main elements of an NC machine and state the function served by each element.
- \*11. How does a CNC machine differ from an NC machine?
- \*12. Define Robot, write the classification based on robot physical configuration, write down the applications of an industrial robot.
- \*13. Classify the robots on the basis of the physical configuration.
- \*14. What is automation? Explain the types of automation with examples.

---

\* indicates that similar questions have appeared in various university examinations.

## Learning Objectives

*By the end of this chapter, the student will be able:*

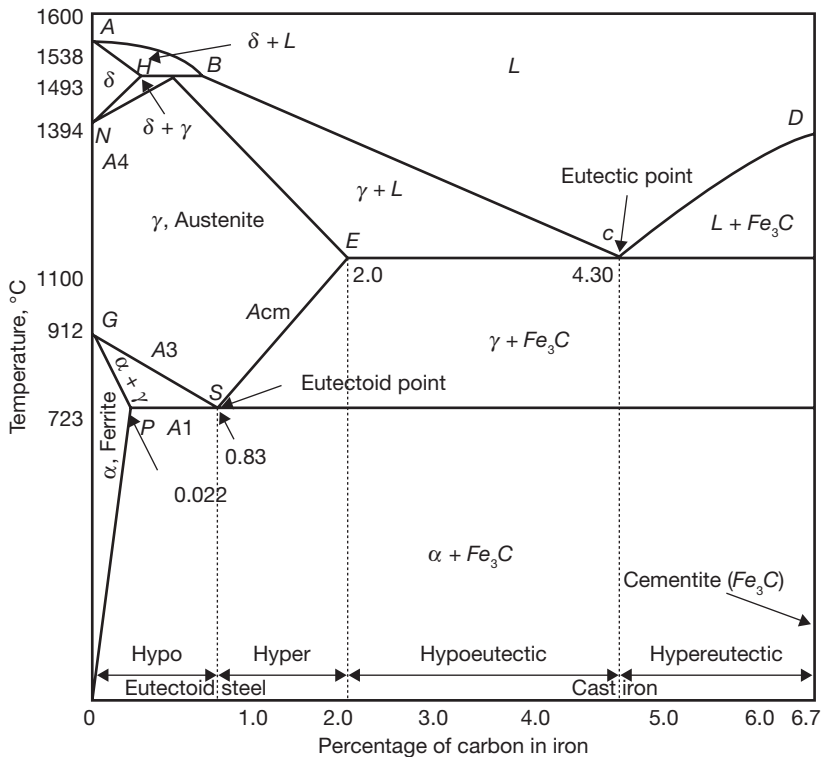
- To demonstrate the iron-carbon (Fe-C) phase diagram
- To demonstrate the time-temperature-transformation (TTT) diagram
- To describe the various heat treatment processes of the metal to change the mechanical properties

### 23.1 ► INTRODUCTION

Heat treatment is a process to control the mechanical properties of engineering materials by heating, cooling and alloying the metal as per requirement. It deals with change in properties by alloying different elements to the metal at various temperatures. The various mechanical properties such as hardness, toughness, ductility, machinability, and grain refinement are controlled by heat treatment process. In this chapter, we deal only with steel and its properties. Some of the basic heat treatment processes such as hardening, normalizing, annealing, tempering, with iron-carbon diagram and time temperature transformation diagram have been introduced.

### 23.2 ► IRON–CARBON PHASE DIAGRAM

Iron-carbon (Fe-C) phase diagram shows the solubility of carbon in iron at different temperature and the corresponding structure of the steel. For describing the Fe-C phase diagram, the equilibrium between Fe and C is considered as metastable.



**FIGURE 23.1**

Fe-C Phase Diagram

The larger phase field of  $\gamma$ -iron (austenite) compared with that of  $\alpha$ -iron (ferrite) reflects the greater solubility of carbon in  $\gamma$ -iron, with a maximum value of just over 2% at 1147°C (E) as shown in Figure 23.1. This high solubility of carbon in  $\gamma$ -iron is of extreme importance in heat treatment when solution treatment in the  $\gamma$ -region followed by rapid quenching to room temperature allows a supersaturated solid solution of carbon in iron to be formed.

The  $\alpha$ -iron phase field is severely restricted, with a maximum carbon solubility of 0.02% at 723°C (P), so over the carbon range encountered in steel from 0.05 to 1.5%,  $\alpha$ -iron is normally associated with iron carbide in one form or another. Similarly, the  $\delta$ -phase field is very restricted between 1390 and 1534°C and disappears completely when the carbon content reaches 0.5% (B). The great difference in carbon solubility between  $\gamma$ - and  $\alpha$ -iron leads normally to the rejection of carbon as iron carbide at the boundaries of the  $\gamma$  phase field. The transformation of  $\gamma$  to  $\alpha$ -iron occurs via a eutectoid reaction, which plays a dominant role in heat treatment. The eutectoid temperature is 723°C while the eutectoid composition is 0.80% C. On cooling alloys containing less than 0.80% C slowly, hypo-eutectoid ferrite is formed from austenite in the range 910–723°C with enrichment of the residual austenite in carbon, until at 723°C the remaining austenite, now containing 0.8% carbon transforms to

pearlite (a lamellar mixture of ferrite and cementite). In austenite with 0.80 to 2.06% carbon, on cooling slowly in the temperature interval 1147°C to 723°C, cementite first forms progressively depleting the austenite in carbon, until at 723°C, the austenite contains 0.8% carbon and transforms to pearlite.

Steels with less than about 0.8% carbon are thus hypo-eutectoid alloys with ferrite and pearlite as the prime constituents, the relative volume fractions being determined by the lever rule which states that as the carbon content is increased, the volume percentage of pearlite increases until it is 100% at the eutectoid composition. Above 0.8% C, cementite becomes the hypereutectoid phase, and a similar variation in volume fraction of cementite and pearlite occurs on this side of the eutectoid composition.

There are several temperatures or critical points in the diagram, which are important, both from the basic and from the practical point of view.

Firstly, there is the  $A_1$ , temperature at which the eutectoid reaction occurs, which is 723°C in the binary diagram.

Secondly, there is the  $A_3$ , temperature when  $\alpha$ -iron transforms to  $\gamma$ -iron. For pure iron, this occurs at 910°C, but the transformation temperature is progressively lowered along the line GS by the addition of carbon.

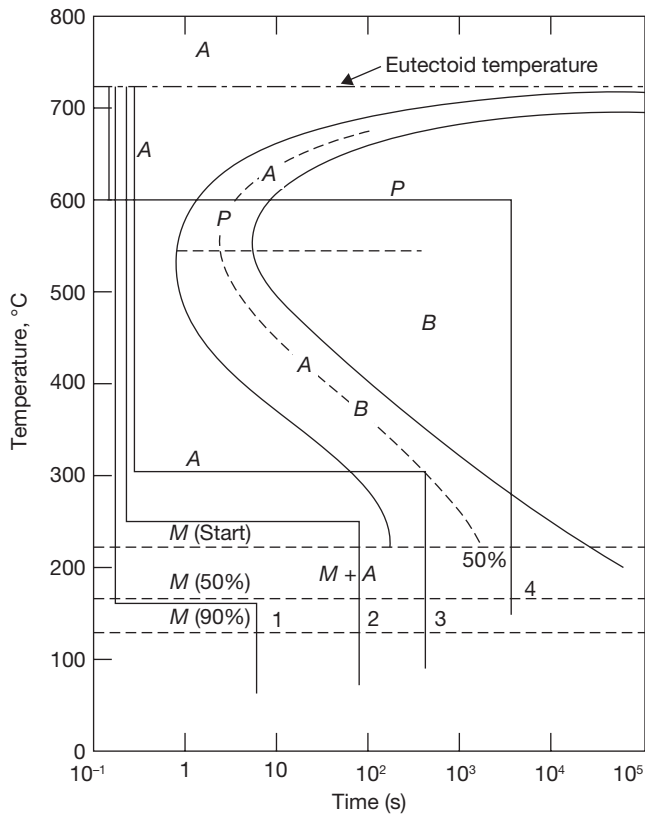
The third point is  $A_4$  at which  $\gamma$ -iron transforms to  $\delta$ -iron, 1390°C in pure iron, but this is raised as carbon is added. The  $A_2$ , the point is the Curie point when iron changes from the ferro- to the paramagnetic condition. This temperature is 769°C for pure iron, but no change in crystal structure is involved. The  $A_1$ ,  $A_3$  and  $A_4$  points are easily detected by thermal analysis during cooling or heating cycles.

### 23.3 ► TTT (TIME–TEMPERATURE–TRANSFORMATION) DIAGRAM

The time-temperature-transformation curves correspond to the start and finish of transformations which extend into the range of temperatures where austenite transforms to pearlite. Above 550°C, austenite transforms completely to pearlite. Below 550°C, both pearlite and bainite are formed and below 450°C, only bainite is formed. The horizontal dotted line that runs between the two curves marks the beginning and end of isothermal transformations. The dashed line that runs parallel to the solid line curves represents the time to transform half the austenite to pearlite.

The transformations through various paths are described below as:

**Path 1:** The specimen is cooled rapidly to 160°C and left for 20 minutes. The cooling rate is too rapid for pearlite to form at higher temperatures; therefore, the steel remains in the austenitic phase until the  $M_s$  temperature is passed, where martensite begins to form. Since 160°C is the temperature at which half of the austenite transforms to martensite, the direct quench converts 50% of the structure to martensite. Holding at 160°C forms only a small quantity of additional martensite, so the structure can be assumed to be half martensite and half retained austenite.



**FIGURE 23.2**

TTT Diagram

**Path 2:** The specimen is held at 250°C for 100 sec, which is not long enough to form bainite. Therefore, the second quench from 250°C to room temperature develops a martensitic structure.

**Path 3:** An isothermal hold at 300°C for 500 sec produces a half-bainite and half-austenite structure. Cooling quickly would result in a final structure of martensite and bainite.

**Path 4:** Austenite converts completely to fine pearlite after eight seconds at 600°C. This phase is stable and will not be changed on holding for 100,000 seconds at 873 K. The final structure when cooled, is fine pearlite.

## 23.4 ► NORMALIZING

Normalizing is a process of heating about 30 to 50°C above higher critical point for the time duration of 15 minutes and cooling in still air.



The purposes of the process normalizing are: (a) to reduce the grain size of steel, (b) to remove the internal stress caused by working, and (c) to improve some of the mechanical properties. The products obtained are ferrite and pearlite for hypoeutectoid steel and pearlite and cementite for hypereutectoid steel. The normalized structure of these two steel consists of sorbite and ferrite. The properties of normalized steel are higher yield point, ultimate tensile strength, impact strength and lower ductility. It is advantageous for low and medium carbon steel. For alloy steel, it is possible with time duration of 2 h cooling in the furnace.

### **23.5 ► ANNEALING**

The purposes of annealing are: (a) to soften the metal for easy machining, (b) to remove internal stress caused by working, (c) to increase ductility, to refine grain size, and (d) to modify electrical and magnetic properties. Normalized steel is less ductile and has more yield point and tensile strength than the annealed steel. There are two types of annealing—process annealing and full annealing.

**Process Annealing:** This is a process of heating the metal below or very close to lower critical temperature, i.e., 650°C for steel and slow cooling to form new grain structure. The purposes of the process are: (a) to increase the ductility of cold worked metal and (b) to remove internal stress. This is frequently used in wire drawing to increase the plasticity of the metal.

**Full Annealing:** The purposes of full annealing are: (a) to soften the steel, (b) to refine grain structure above the upper critical limit by 20 to 30°C for 0.9% C-steel and by the same amount below the critical point for high carbon steel. Carbon-steel is cooled 100° to 200°C per hour. It is essential that the steel should not hold less than 4 to 8 min for heating. To prevent the steel for carburization and oxidization workpiece is closed in a metal box and put into the furnace. Austenite changes to pearlite and mixture of pearlite and ferrite.

### **23.6 ► SPHEROIDIZING**

Spheroidizing is used to improve the machinability of steel. The workpiece is heated to 730–770°C, slightly above the lower critical temperature, and cooled 25–30°C per hour.

### **23.7 ► HARDENING**

The purposes of hardening are: (a) to harden the steel to resist wear, (b) to enable it to cut other metal. The metal is heated 30–50°C above the upper critical temperature for hypoeutectoid steel and above the same amount above the lower critical temperature for hypereutectoid steel. It is left for soaking for considered time. Quenching of high carbon steel heated to 1100–1300°C is done in a current of air. Quenching 150–200°C per sec in solution 3–10% caustic soda and 5–15% salt is more rapid than the quenching effect in water at 20°C and 32–42°C for oil quenching.

## 23.8 ► TEMPERING

Tempering is a process of reheating of hardened steel below critical range and cooled at the decreased rate (approximately 4 to 5 minutes for each mm of the section). There is the partial transformation of martensite to secondary constituent troosite and sorbite. The purposes of tempering are: (a) to reduce some amount of hardness produced during hardening and increase the ductility and (b) to remove strain produced during heating.

*Low-temperature Tempering:* Steel is heated to 150–250°C and cooled down. This is used to remove internal stress, reduce hardness, and increase ductility without changing the steel structure.

*Medium-temperature Tempering:* Steel is heated to 350–450°C and cooled down. Martensite is changed is changed to secondary troosite. It results in a reduction in strength and hardness, and increase in ductility. It is used for the part which is to be used in impact loadings such as chisel, hammer, spring, and spring plates.

*High-temperature Tempering:* Steel is heated to 500–600°C and cooled down. Martensite is changed to sorbite. Internal stress is relieved completely. This is used for the part subjected to high impact and stress such as gear wheels, shafts, and connecting rod, etc.

### 23.8.1 Austempering

This is the method that can be used to overcome the restrictions of conventional quench and tempering. The quench is interrupted at a higher temperature than for Martempering to allow the metal at the center of the part to reach the same temperature as the surface. By maintaining that temperature, both the center and the surface are allowed to transform to Bainite and are then cooled to room temperature.

The austempering heat treatment consists of three steps— austenitization in the temperature range of 840–950°C for a time sufficient to produce fully austenitic matrix, rapid cooling of the entire part to an austempering temperature in the range of 230–450°C without any transformations, and isothermal treatment at the austempering temperature, at which during the transformation only bainitic ferrite forms in a favorable case. Advantages of austempering are less distortion and cracking than Martempering, no need for final tempering, improvement of toughness, and Improved ductility. Limitation of austempering is that the austempering can be applied to parts where the transformation to pearlite can be avoided. This means that the section must be cooled fast enough to avoid the formation of pearlite. Thin sections can be cooled faster than the bulky sections.

### 23.8.2 Martempering

Martempering or marquenching permits the transformation of Austenite to Martensite to take place at the same time throughout the structure of the metal part. By using interrupted quench, the cooling is stopped at a point above the martensite transformation region to

allow sufficient time for the center to cool to the same temperature as the surface. The cooling is continued through the martensite region, followed by the usual tempering.

Martempering of steel (and of cast iron) consists of quenching from the austenitizing temperature into a hot fluid medium (hot oil, molten salt, molten metal, or a fluidized particle bed) at a temperature usually above the martensite range ( $M_s$  point), holding in the quenching medium until the temperature throughout the steel is substantially uniform, and cooling (usually in air) at a moderate rate to prevent large differences in temperature between the outside and the center of the section.

The advantage of martempering lies in the reduced thermal gradient between surface and center as the part is quenched to the isothermal temperature and then is air cooled to room temperature. Residual stresses developed during martempering are lower than those developed during conventional quenching. Martempering also reduces or eliminates susceptibility to cracking. Another advantage of martempering in a molten salt is the control of surface carburizing or decarburizing.

### 23.9 ► CARBURIZING

Carburizing is a heat treatment process in which iron or steel absorbs carbon liberated when the metal is heated in the presence of a carbon rich atmosphere, such as charcoal or carbon monoxide, with the intent of making the metal harder. Depending on the amount of time and temperature, the affected area can vary in carbon content. Longer carburizing times and higher temperatures lead to greater carbon diffusion into the part as well as increased depth of carbon diffusion. When the iron or steel is quenched, the higher carbon content on the outer surface becomes hard via the transformation from austenite to martensite, while the core remains soft and tough as a ferritic and/or pearlite microstructure. It is applied to low-carbon workpieces; workpieces are in contact with a high-carbon gas, liquid or solid; it produces a hard workpiece surface; workpiece cores largely retain their toughness and ductility, and it produces case hardness depths of up to 6.4 mm.

*Gas Carburizing:* It is a heat treatment process, which improves the case depth hardness of a component by diffusing carbon into the surface layer to improve wear and fatigue resistance. The workpieces are pre-heated and then held for a period of time at an elevated temperature in the austenitic region of the specific alloy, typically between 820 and 940°C. During the thermal cycle the components are subject to an enriched carbon atmosphere such that nascent species of carbon can diffuse into the surface layers of the component. The rate of diffusion is dependent on the alloy and carbon potential of the atmosphere. Care must be taken to ensure that only sufficient carbon is available in the atmosphere at any one time to satisfy the take-up rate of the alloy to accept the carbon atoms.

*Pack Carburizing:* It is a heat treatment process in which carbon monoxide derived from a solid compound decomposes at the metal surface into nascent carbon and carbon dioxide. The nascent carbon is absorbed into the metal, and the carbon dioxide immediately reacts

with carbonaceous material present in the solid carburizing compound to produce fresh carbon monoxide. The formation of carbon monoxide is enhanced by energizers or catalysts, such as barium carbonate, calcium carbonate, potassium carbonate, and sodium carbonate that are present in the carburizing compound. These energizers facilitate the reduction of carbon dioxide with carbon to form carbon monoxide. Thus, in a closed system, the amount of energizer does not change. Carburizing continues as long as enough carbon is present to react with the excess carbon dioxide. Pack carburizing is no longer a major commercial process.

### 23.10 ► CYANIDING

Steel parts may be surface-hardened by heating in contact with a cyanide salt, followed by quenching. Only a thin case is obtained by this method. Cyaniding is, however, a rapid and economical method of case hardening, and may be used in some instances for relatively unimportant parts. The work to be hardened is immersed in a bath of molten sodium or potassium cyanide from 30 to 60 minutes. The cyanide bath should be mainlined at a temperature to 760 to 899°C. Immediately, after removal from the bath, the parts are quenched in water. The case obtained in this manner is due principally to the formation of carbides and nitrides on the surface of the steel. The use of a closed pot and ventilating hood are required for cyaniding, as cyanide vapors are extremely poisonous.

### 23.11 ► NITRIDING

This method is advantageous due to the fact that a harder case is obtained than by carburizing. Many engine parts such as cylinder barrels and gears may be treated in this way. Nitriding is generally applied to certain special steel alloys, one of the essential constituents of which is aluminum. The process involves the exposing of the parts to ammonia gas or other nitrogenous materials for 20 to 100 h at 500–650°C. The container in which the work and ammonia gas are brought into contact must be airtight and capable of maintaining good circulation and even temperature throughout. The depth of case obtained by nitriding is about 0.2 to 0.4 mm if heated for 50 h. The nitriding process does not affect the physical state of the core if the preceding tempering temperature was 500°C or over.

### 23.12 ► INDUCTION HARDENING

This process involves heating applied rapidly and locally to the steel component followed by quenching. High-frequency electric fields quickly heat the surface of the component via induction coils, which is then quenched using water. This results in a localized hardened layer at the surface. Different shaped inductor coils are available and can be made to suit. Induction Hardening offers a cost effective low distortion surface hardening treatment to steels, particularly large components where an increase in surface hardness is required whilst maintaining core properties.



## RECAP ZONE .....

### Points to Remember

- **Heat treatment** is a process to control the mechanical properties of engineering materials by heating, cooling and alloying the metal as per requirement.
- **Iron-carbon (Fe-C) phase diagram** shows the solubility of carbon in iron at different temperature and the corresponding structure of the steel.
- Firstly, there is the  $A_1$ , temperature at which the eutectoid reaction occurs, which is  $723^\circ\text{C}$  in the binary diagram.
- Secondly, there is the  $A_3$ , temperature when  $\alpha$ -iron transforms to  $\gamma$ -iron. For pure iron this occurs at  $910^\circ\text{C}$ , but the transformation temperature is progressively lowered along the line GS by the addition of carbon.
- The third point is  $A_4$  at which  $\gamma$ -iron transforms to  $\delta$ -iron,  $1390^\circ\text{C}$  in pure iron, but this is raised as carbon is added.
- The **time-temperature-transformation curves** correspond to the start and finish of transformations which extend into the range of temperatures where austenite transforms to pearlite.
- Above  $550^\circ\text{C}$ , austenite transforms completely to pearlite. Below  $550^\circ\text{C}$ , both pearlite and bainite are formed and below  $450^\circ\text{C}$ , only bainite is formed.
- **Normalizing** is a process of heating about 30 to  $50^\circ\text{C}$  above higher critical point for the time duration of 15 min and cooling in still air.
- The purposes of the process normalizing are: (a) to reduce grain size of steel, (b) to remove internal stress caused by working, and (c) to improve some of the mechanical properties.
- The purposes of **annealing** are: (a) to soften the metal for easy machining, (b) to remove the internal stress caused by working, (c) to increase ductility, to refine the grain size, and (d) to modify the electrical and magnetic properties.
- Normalized steel is less ductile and has more yield point and tensile strength than the annealed steel.
- **Tempering** is a process of reheating of hardened steel below critical range and cooled at the decreased rate (approximately 4 to 5 min for each mm of the section). There is the partial transformation of martensite to secondary constituent troosite and sorbite.
- The purposes of tempering are: (a) to reduce some amount of hardness produced during hardening and increase the ductility and (b) to remove strain produced during heating.
- **Carburizing** is a heat treatment process in which iron or steel absorbs carbon liberated when the metal is heated in the presence of a carbon rich atmosphere, such as charcoal or carbon monoxide, with the intent of making the metal harder.
- Steel parts may be surface-hardened by heating in contact with a cyanide salt, followed by quenching.
- This process involves heating applied rapidly and locally to the steel component followed by quenching. High-frequency electric fields quickly heat the surface of the component via induction coils, which is then quenched using water.



## REVIEW ZONE

### Multiple-choice Questions

- The heat treatment process in which steel is heated above upper critical temperature and then cooled in air is known as:
  - Annealing
  - Normalizing
  - Austempering
  - Martempering
- The heat treatment process in which steel is heated above upper critical temperature and then cooled in furnace is known as:
  - Annealing
  - Normalizing
  - Austempering
  - Martempering
- In nitriding steel components, the following atmosphere is generally used in the furnace:
  - Inert
  - Nascent nitrogen
  - Liquid nitrogen
  - Ammonia
- Austempering is the heat treatment process used to obtain greater:
  - Hardness
  - Toughness
  - Softness
  - Brittleness
- Low carbon steel can be hardened by:
  - Hardening
  - Heating and quenching in oil
  - Heating and quenching in water
  - Carburizing and cyaniding
- The hardening strains are reduced and the toughness of the part increased by the following process after hardening:
  - Annealing
  - Tempering
  - Carburizing
  - Anodizing
- A small selected portion of the job can be hardened by:
  - Flame and induction hardening
  - Pack hardening
  - Cyaniding
  - Case hardening
- Which of the following is a case hardening process:
  - Spheroidising
  - Tempering
  - Cyaniding
  - Parkerising
- Martensite is a supersaturated solution of carbon in:
  - Iron
  - Steel
  - $\alpha$ -iron
  - $\delta$ -iron
- Martensite is a structure obtained by:
  - Quenching austenite
  - Quenching austenite and heating into the range of 200 to 375°C
  - Quenching austenite and heating into the range of 375 to 660°C
  - Quenching austenite and heating into the range of 600 to 700°C

### Fill in the Blanks

- Troosite is the structure obtained by quenching austenite and heating at \_\_\_\_\_ °C.
- Line  $A_1$  on iron-carbon diagram indicates completion of austenite transition to \_\_\_\_\_.
- Line  $A_{cm}$  on iron-carbon diagram indicates limit of carbon solubility in \_\_\_\_\_.
- Line  $A_3$  on iron-carbon diagram indicates the beginning of transition from austenite to \_\_\_\_\_.
- Eutectoid composition of carbon steel at room temperature is known as \_\_\_\_\_.

## Answers

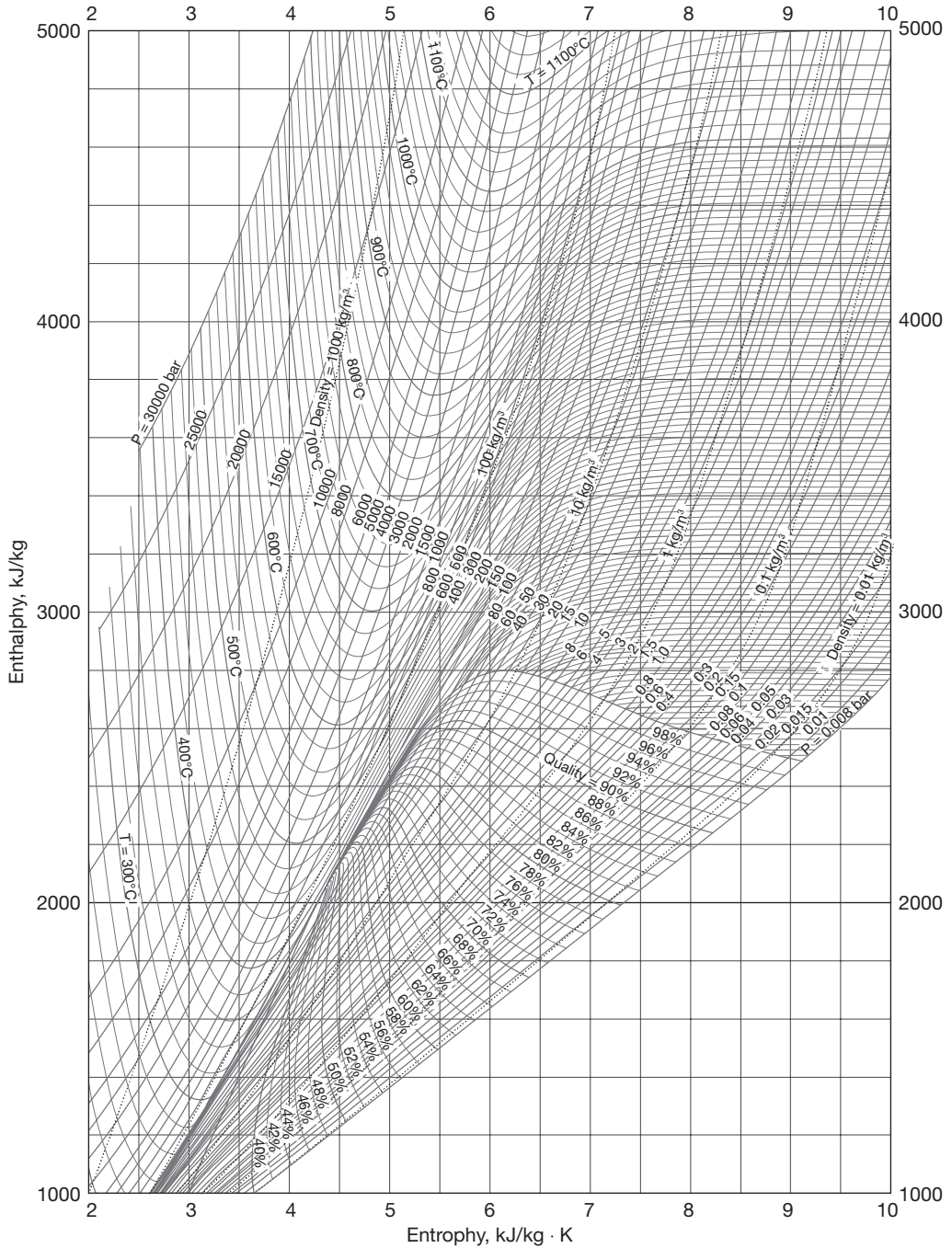
- |             |               |             |              |         |        |
|-------------|---------------|-------------|--------------|---------|--------|
| 1. (b)      | 2. (a)        | 3. (d)      | 4. (a)       | 5. (d)  | 6. (b) |
| 7. (a)      | 8. (c)        | 9. (a)      | 10. (b)      | 11. 600 |        |
| 12. ferrite | 13. austenite | 14. ferrite | 15. pearlite |         |        |

## Theory Questions

1. What is heat treatment? Discuss its importance in metallurgy.
2. Write the importance of FE-C diagram? Draw the diagram and explain the solubility of carbon in iron at the different temperature.
3. Draw the TTT diagram and explain the isothermal transformation process.
4. Differentiate between normalizing and annealing.
5. Write notes on the process and full annealing.
6. Differentiate between austempering and martempering.
7. Differentiate between hardening and tempering.
8. Write notes on: (i) case hardening, (ii) pack carburizing, (iii) nitriding, (iv) cyaniding, and (v) induction hardening.
- \*9. What is tempering? What are its objectives?
- \*10. Explain various case hardening processes of steel.

\* indicates that similar questions have appeared in various university examinations.

# Appendix 1: Mollier Diagram for Steam





# Appendix 2: Steam Table

**TABLE A.2–1 Saturated Steam—Temperature Table**

Temp. $T$ °C	Sat. Press. $P_{sat}$ kPa	Specific volume $m^3/kg$		Internal energy $kJ/kg$			Enthalpy $kJ/kg$			Entropy $kJ/kg\cdot K$		
		Sat. Liquid $v_f$	Sat. Vapor $v_g$	Sat. Liquid $u_f$	Evap. $u_{fg}$	Sat. Vapor $u_g$	Sat. Liquid $h_f$	Evap. $h_{fg}$	Sat. Vapor $h_g$	Sat. Liquid $s_f$	Evap. $s_{fg}$	Sat. Vapor $s_g$
0.01	0.6117	0.001000	206.00	0.000	2374.9	2374.9	0.001	2500.9	2500.9	0.0000	9.1556	9.1556
5	0.8725	0.001000	147.03	21.019	2360.8	2381.8	21.020	2489.1	2510.1	0.0763	8.9487	9.0249
10	1.2281	0.001000	106.32	42.020	2346.6	2388.7	42.022	2477.2	2519.2	0.1511	8.7488	8.8999
15	1.7057	0.001001	77.885	62.980	2332.5	2395.5	62.982	2465.4	2528.3	0.2245	8.5559	8.7803
20	2.3392	0.001002	57.762	83.913	2318.4	2402.3	83.915	2453.5	2537.4	0.2965	8.3696	8.6661
25	3.1698	0.001003	43.340	104.83	2304.3	2409.1	104.83	2441.7	2546.5	0.3672	8.1895	8.5567
30	4.2469	0.001004	32.879	125.73	2290.2	2415.9	125.74	2429.8	2555.6	0.4368	8.0152	8.4520
35	5.6291	0.001006	25.205	146.63	2276.0	2422.7	146.64	2417.9	2564.6	0.5051	7.8466	8.3517
40	7.3851	0.001008	19.515	167.53	2261.9	2429.4	167.53	2406.0	2573.5	0.5724	7.6832	8.2556
45	9.5953	0.001010	15.251	188.43	2247.7	2436.1	188.44	2394.0	2582.4	0.6386	7.5247	8.1633
50	12.352	0.001012	12.026	209.33	2233.4	2442.7	209.34	2382.0	2591.3	0.7038	7.3710	8.0748
55	15.763	0.001015	9.5639	230.24	2219.1	2449.3	230.26	2369.8	2600.1	0.7680	7.2218	7.9898
60	19.947	0.001017	7.6670	251.16	2204.7	2455.9	251.18	2357.7	2608.8	0.8313	7.0769	7.9082
65	25.043	0.001020	6.1935	272.09	2190.3	2462.4	272.12	2345.4	2617.5	0.8937	6.9360	7.8296
70	31.202	0.001023	5.0396	293.04	2175.8	2468.9	293.07	2333.0	2626.1	0.9551	6.7989	7.7540
75	38.597	0.001026	4.1291	313.99	2161.3	2475.3	314.03	2320.6	2634.6	1.0158	6.6655	7.6812
80	47.416	0.001029	3.4053	334.97	2146.6	2481.6	335.02	2308.0	2643.0	1.0756	6.5355	7.6111
85	57.868	0.001032	2.8261	355.96	2131.9	2487.8	356.02	2295.3	2651.4	1.1346	6.4089	7.5435
90	70.183	0.001036	2.3593	376.97	2117.0	2494.0	377.04	2282.5	2659.6	1.1929	6.2853	7.4782
95	84.609	0.001040	1.9808	398.00	2102.0	2500.1	398.09	2269.6	2667.6	1.2504	6.1647	7.4151
100	101.42	0.001043	1.6720	419.06	2087.0	2506.0	419.17	2256.4	2675.6	1.3072	6.0470	7.3542
105	120.90	0.001047	1.4186	440.15	2071.8	2511.9	440.28	2243.1	2683.4	1.3634	5.9319	7.2952
110	143.38	0.001052	1.2094	461.27	2056.4	2517.7	461.42	2229.7	2691.1	1.4188	5.8193	7.2382
115	169.18	0.001056	1.0360	482.42	2040.9	2523.3	482.59	2216.0	2698.6	1.4737	5.7092	7.1829
120	198.67	0.001060	0.89133	503.60	2025.3	2528.9	503.81	2202.1	2706.0	1.5279	5.6013	7.1292

Temp. <i>T</i> °C	Sat. Press. <i>P<sub>sat</sub></i> kPa	Specific volume m <sup>3</sup> /kg		Internal energy kJ/kg			Enthalpy kJ/kg			Entropy kJ/kg-K		
		Sat. Liquid <i>v<sub>f</sub></i>	Sat. Vapor <i>v<sub>g</sub></i>	Sat. Liquid <i>u<sub>f</sub></i>	Evap. <i>u<sub>fg</sub></i>	Sat. Vapor <i>u<sub>g</sub></i>	Sat. Liquid <i>h<sub>f</sub></i>	Evap. <i>h<sub>fg</sub></i>	Sat. Vapor <i>h<sub>g</sub></i>	Sat. Liquid <i>s<sub>f</sub></i>	Evap. <i>s<sub>fg</sub></i>	Sat. Vapor <i>s<sub>g</sub></i>
125	232.23	0.001065	0.77012	524.83	2009.5	2534.3	525.07	2188.1	2713.1	1.5816	5.4956	7.0771
130	270.28	0.001070	0.66808	546.10	1993.4	2539.5	546.38	2173.7	2720.1	1.6346	5.3919	7.0265
135	313.22	0.001075	0.58179	567.41	1977.3	2544.7	567.75	2169.1	2726.9	1.6872	5.2901	6.9773
140	361.53	0.001080	0.50850	588.77	1960.9	2549.6	589.16	2144.3	2733.5	1.7392	5.1901	6.9294
145	415.68	0.001085	0.44600	610.19	1944.2	2554.4	610.64	2129.2	2739.8	1.7908	5.0919	6.8827
150	476.16	0.001091	0.39248	631.66	1927.4	2559.1	632.18	2113.8	2745.9	1.8418	4.9953	6.8371
155	543.49	0.001096	0.34648	653.19	1910.3	2563.5	653.79	2098.0	2751.8	1.8924	4.9002	6.7927
160	618.23	0.001102	0.30680	674.79	1893.0	2567.8	675.47	2082.0	2757.5	1.9426	4.8066	6.7492
165	700.93	0.001108	0.27244	696.46	1875.4	2571.9	697.24	2065.6	2762.8	1.9923	4.7143	6.7067
170	792.18	0.001114	0.24260	718.20	1857.5	2575.7	719.08	2048.8	2767.9	2.0417	4.6233	6.6650
175	892.60	0.001121	0.21659	740.02	1839.4	2579.4	741.02	2031.7	2772.7	2.0906	4.5335	6.6242
180	1002.8	0.001127	0.19384	761.92	1820.9	2582.8	763.05	2014.2	2777.2	2.1392	4.4448	6.5841
185	1123.5	0.001134	0.17390	783.91	1802.1	2586.0	785.19	1996.2	2781.4	2.1875	4.3572	6.5447
190	1255.2	0.001141	0.15636	806.00	1783.0	2589.0	807.43	1977.9	2785.3	2.2355	4.2705	6.5059
195	1398.8	0.001149	0.14089	828.18	1763.6	2591.7	829.78	1959.0	2788.8	2.2831	4.1847	6.4678
200	1554.9	0.001157	0.12721	850.46	1743.7	2594.2	852.26	1939.8	2792.0	2.3305	4.0997	6.4302
205	1724.3	0.001164	0.11508	872.86	1723.5	2596.4	874.87	1920.0	2794.8	2.3776	4.0154	6.3930
210	1907.7	0.001173	0.10429	895.38	1702.9	2598.3	897.61	1899.7	2797.3	2.4245	3.9318	6.3563
215	2105.9	0.001181	0.094680	918.02	1681.9	2599.9	920.50	1878.8	2799.3	2.4712	3.8489	6.3200
220	2319.6	0.001190	0.086094	940.79	1660.5	2601.3	943.55	1857.4	2801.0	2.5176	3.7664	6.2840
225	2549.7	0.001199	0.078405	963.70	1638.6	2602.3	966.76	1835.4	2802.2	2.5639	3.6844	6.2483
230	2797.1	0.001209	0.071505	986.76	1616.1	2602.9	990.14	1812.8	2802.9	2.6100	3.6028	6.2128
235	3062.6	0.001219	0.065300	1010.0	1593.2	2603.2	1013.7	1789.5	2803.2	2.6560	3.5216	6.1775
240	3347.0	0.001229	0.059707	1033.4	1569.8	2603.1	1037.5	1765.5	2803.0	2.7018	3.4405	6.1424
245	3651.2	0.001240	0.054656	1056.9	1545.7	2602.7	1061.5	1740.8	2802.2	2.7476	3.3596	6.1072
250	3976.2	0.001252	0.050085	1080.7	1521.1	2601.8	1085.7	1715.3	2801.0	2.7933	3.2788	6.0721
255	4322.9	0.001263	0.045941	1104.7	1495.8	2600.5	1110.1	1689.0	2799.1	2.8390	3.1979	6.0369
260	4692.3	0.001276	0.042175	1128.8	1469.9	2598.7	1134.8	1661.8	2796.6	2.8847	3.1169	6.0017
265	5085.3	0.001289	0.038748	1153.3	1443.2	2596.5	1159.8	1633.7	2793.5	2.9304	3.0358	5.9662
270	5503.0	0.001303	0.035622	1177.9	1415.7	2593.7	1185.1	1604.6	2789.7	2.9762	2.9542	5.9305
275	5946.4	0.001317	0.032767	1202.9	1387.4	2590.3	1210.7	1574.5	2785.2	3.0221	2.8723	5.8944
280	6416.6	0.001333	0.030153	1228.2	1358.2	2586.4	1236.7	1543.2	2779.9	3.0681	2.7898	5.8579
285	6914.6	0.001349	0.027756	1253.7	1328.1	2581.8	1263.1	1510.7	2773.7	3.1144	2.7066	5.8210
290	7441.8	0.001366	0.025554	1279.7	1296.9	2576.5	1289.8	1476.9	2766.7	3.1608	2.6225	5.7834
295	7999.0	0.001384	0.023528	1306.0	1264.5	2570.5	1317.1	1441.6	2758.7	3.2076	2.5374	5.7450

(Continued)

TABLE A.2-1 (Continued)

Temp. $T^{\circ}\text{C}$	Sat. Press. $P_{\text{sat}}$ kPa	Specific volume $\text{m}^3/\text{kg}$		Internal energy kJ/kg			Enthalpy kJ/kg			Entropy kJ/kg-K		
		Sat. Liquid $v_f$	Sat. Vapor $v_g$	Sat. Liquid $u_f$	Evap. $u_{fg}$	Sat. Vapor $u_g$	Sat. Liquid $h_f$	Evap. $h_{fg}$	Sat. Vapor $h_g$	Sat. Liquid $s_f$	Evap. $s_{fg}$	Sat. Vapor $s_g$
300	8587.9	0.001404	0.021659	1332.7	1230.9	2563.6	1344.8	1404.8	2749.6	3.2548	2.4511	5.7059
305	9209.4	0.001425	0.019932	1360.0	1195.9	2555.8	1373.1	1366.3	2739.4	3.3024	2.3633	5.6657
310	9865.0	0.001447	0.018333	1387.7	1159.3	2547.1	1402.0	1325.9	2727.9	3.3506	2.2737	5.6243
315	10,556	0.001472	0.016849	1416.1	1121.1	2537.2	1431.6	1283.4	2715.0	3.3994	2.1821	5.5816
320	11,284	0.001499	0.015470	1445.1	1080.9	2526.0	1462.0	1238.5	2700.6	3.4491	2.0881	5.5372
325	12,051	0.001528	0.014183	1475.0	1038.5	2513.4	1493.4	1191.0	2684.3	3.4998	1.9911	5.4908
330	12,858	0.001560	0.012979	1505.7	993.5	2499.2	1525.8	1140.3	2666.0	3.5516	1.8906	5.4422
335	13,707	0.001597	0.011848	1537.5	945.5	2483.0	1559.4	1086.0	2645.4	3.6050	1.7857	5.3907
340	14,601	0.001638	0.010783	1570.7	893.8	2464.5	1594.6	1027.4	2622.0	3.6602	1.6756	5.3358
345	15,541	0.001685	0.009772	1605.5	837.7	2443.2	1631.7	963.4	2595.1	3.7179	1.5585	5.2765
350	16,529	0.001741	0.008806	1642.4	775.9	2418.3	1671.2	892.7	2563.9	3.7788	1.4326	5.2114
355	17,570	0.001808	0.007872	1682.2	706.4	2388.6	1714.0	812.9	2526.9	3.8442	1.2942	5.1384
360	18,666	0.001895	0.006950	1726.2	625.7	2351.9	1761.5	720.1	2481.6	3.9165	1.1373	5.0537
365	19,822	0.002015	0.006009	1777.2	526.4	2303.6	1817.2	605.5	2422.7	4.0004	0.9489	4.9493
370	21,044	0.002217	0.004953	1844.5	385.6	2230.1	1891.2	443.1	2334.3	4.1119	0.6890	4.8009
373.95	22,064	0.003106	0.003106	2015.7	0	2015.7	2084.3	0	2084.3	4.4070	0	4.4070

TABLE A.2-2 Saturated Steam—Pressure Table

Press. $P$ kPa	Sat. Temp. $T_{\text{sat}}$ $^{\circ}\text{C}$	Specific volume $\text{m}^3/\text{kg}$		Internal energy kJ/kg			Enthalpy kJ/kg			Entropy kJ/kg-K		
		Sat. Liquid $v_f$	Sat. Vapor $v_g$	Sat. Liquid $u_f$	Evap. $u_{fg}$	Sat. Vapor $u_g$	Sat. Liquid $h_f$	Evap. $h_{fg}$	Sat. Vapor $h_g$	Sat. Liquid $s_f$	Evap. $s_{fg}$	Sat. Vapor $s_g$
1.0	6.97	0.001000	129.19	29.302	2355.2	2384.5	29.303	2484.4	2513.7	0.1059	8.8690	8.9749
1.5	13.02	0.001001	87.964	54.686	2338.1	2392.8	54.688	2470.1	2524.7	0.1956	8.6314	8.8270
2.0	17.50	0.001001	66.990	73.431	2325.5	2398.9	73.433	2459.5	2532.9	0.2606	8.4621	8.7227
2.5	21.08	0.001002	54.242	88.422	2315.4	2403.8	88.424	2451.0	2539.4	0.3118	8.3302	8.6421
3.0	24.08	0.001003	45.654	100.98	2306.9	2407.9	100.98	2443.9	2544.8	0.3543	8.2222	8.5765
4.0	28.96	0.001004	34.791	121.39	2293.1	2414.5	121.39	2432.3	2553.7	0.4224	8.0510	8.4734
5.0	32.87	0.001005	28.185	137.75	2282.1	2419.8	137.75	2423.0	2560.7	0.4762	7.9176	8.3938
7.5	40.29	0.001008	19.233	168.74	2261.1	2429.8	168.75	2405.3	2574.0	0.5763	7.6738	8.2501
10	45.81	0.001010	14.670	191.79	2245.4	2437.2	191.81	2392.1	2583.9	0.6492	7.4996	8.1488
15	53.97	0.001014	10.020	225.93	2222.1	2448.0	225.94	2372.3	2598.3	0.7549	7.2522	8.0071
20	60.06	0.001017	7.6481	251.40	2204.6	2456.0	251.42	2357.5	2608.9	0.8320	7.0752	7.9073
25	64.96	0.001020	6.2034	271.93	2190.4	2462.4	271.96	2345.5	2617.5	0.8932	6.9370	7.8302

Press. P kPa	Sat. Temp. $T_{sat}$ °C	Specific volume m <sup>3</sup> /kg		Internal energy kJ/kg			Enthalpy kJ/kg			Entropy kJ/kg-K		
		Sat. Liquid $v_f$	Sat. Vapor $v_g$	Sat. Liquid $u_f$	Evap. $u_{fg}$	Sat. Vapor $u_g$	Sat. Liquid $h_f$	Evap. $h_{fg}$	Sat. Vapor $h_g$	Sat. Liquid $s_f$	Evap. $s_{fg}$	Sat. Vapor $s_g$
30	69.09	0.001022	5.2287	289.24	2178.5	2467.7	289.27	2335.3	2624.6	0.9441	6.8234	7.7675
40	75.86	0.001026	3.9933	317.58	2158.8	2476.3	317.62	2318.4	2636.1	1.0261	6.6430	7.6691
50	81.32	0.001030	3.2403	340.49	2142.7	2483.2	340.54	2304.7	2645.2	1.0912	6.5019	7.5931
75	91.76	0.001037	2.2172	384.36	2111.8	2496.1	384.44	2278.0	2662.4	1.2132	6.2426	7.4558
100	99.61	0.001043	1.6941	417.40	2088.2	2505.6	417.51	2257.5	2675.0	1.3028	6.0562	7.3589
101.325	99.97	0.001043	1.6734	418.95	2087.0	2506.0	419.06	2256.5	2675.6	1.3069	6.0476	7.3545
125	105.97	0.001048	1.3750	444.23	2068.8	2513.0	444.36	2240.6	2684.9	1.3741	5.9100	7.2841
150	111.35	0.001053	1.1594	466.97	2052.3	2519.2	467.13	2226.0	2693.1	1.4337	5.7894	7.2231
175	116.04	0.001057	1.0037	486.82	2037.7	2524.5	487.01	2213.1	2700.2	1.4850	5.6865	7.1716
200	120.21	0.001061	0.88578	504.50	2024.6	2529.1	504.71	2201.6	2706.3	1.5302	5.5968	7.1270
225	123.97	0.001064	0.79329	520.47	2012.7	2533.2	520.71	2191.0	2711.7	1.5706	5.5171	7.0877
250	127.41	0.001067	0.71873	535.08	2001.8	2536.8	535.35	2181.2	2716.5	1.6072	5.4453	7.0525
275	130.58	0.001070	0.65732	548.57	1991.6	2540.1	548.86	2172.0	2720.9	1.6408	5.3800	7.0207
300	133.52	0.001073	0.60582	561.11	1982.1	2543.2	561.43	2163.5	2724.9	1.6717	5.3200	6.9917
325	136.27	0.001076	0.56199	572.84	1973.1	2545.9	573.19	2155.4	2728.6	1.7005	5.2645	6.9650
350	138.86	0.001079	0.52422	583.89	1964.6	2548.5	584.26	2147.7	2732.0	1.7274	5.2128	6.9402
375	141.30	0.001081	0.49133	594.32	1956.6	2550.9	594.73	2140.4	2735.1	1.7526	5.1645	6.9171
400	143.61	0.001084	0.46242	604.22	1948.9	2553.1	604.66	2133.4	2738.1	1.7765	5.1191	6.8955
450	147.90	0.001088	0.41392	622.65	1934.5	2557.1	623.14	2120.3	2743.4	1.8205	5.0356	6.8561
500	151.83	0.001093	0.37483	639.54	1921.2	2560.7	640.09	2108.0	2748.1	1.8604	4.9603	6.8207
550	155.46	0.001097	0.34261	655.16	1908.8	2563.9	655.77	2096.6	2752.4	1.8970	4.8916	6.7886
600	158.83	0.001101	0.31560	669.72	1897.1	2566.8	670.38	2085.8	2756.2	1.9308	4.8285	6.7593
650	161.98	0.001104	0.29260	683.37	1886.1	2569.4	684.08	2075.5	2759.6	1.9623	4.7699	6.7322
700	164.95	0.001108	0.27278	696.23	1875.6	2571.8	697.00	2065.8	2762.8	1.9918	4.7153	6.7071
750	167.75	0.001111	0.25552	708.40	1865.6	2574.0	709.24	2056.4	2765.7	2.0195	4.6642	6.6837
800	170.41	0.001115	0.24035	719.97	1856.1	2576.0	720.87	2047.5	2768.3	2.0457	4.6160	6.6616
850	172.94	0.001118	0.22690	731.00	1846.9	2577.9	731.95	2038.8	2770.8	2.0705	4.5705	6.6409
900	175.35	0.001121	0.21489	741.55	1838.1	2579.6	742.56	2030.5	2773.0	2.0941	4.5273	6.6213
950	177.66	0.001124	0.20411	751.67	1829.6	2581.3	752.74	2022.4	2775.2	2.1166	4.4862	6.6027
1000	179.88	0.001127	0.19436	761.39	1821.4	2582.8	762.51	2014.5	2777.1	2.1381	4.4470	6.5850
1100	184.06	0.001133	0.17745	779.78	1805.7	2585.5	781.03	1999.6	2780.7	2.1785	4.3735	6.5520
1200	187.96	0.001138	0.16326	796.96	1790.9	2587.8	798.33	1985.4	2783.8	2.2159	4.3058	6.5217
1300	191.60	0.001144	0.15119	813.10	1776.8	2589.9	814.59	1971.9	2786.5	2.2508	4.2428	6.4936
1400	195.04	0.001149	0.14078	828.35	1763.4	2591.8	829.96	1958.9	2788.9	2.2835	4.1840	6.4675
1500	198.29	0.001154	0.13171	842.82	1750.6	2593.4	844.55	1946.4	2791.0	2.3143	4.1287	6.4430
1750	205.72	0.001166	0.11344	876.12	1720.6	2596.7	878.16	1917.1	2795.2	2.3844	4.0033	6.3877

(Continued)

TABLE A.2–2 (Continued)

Press. P kPa	Sat. Temp. $T_{sat}$ °C	Specific volume m <sup>3</sup> /kg		Internal energy kJ/kg			Enthalpy kJ/kg			Entropy kJ/kg-K		
		Sat. Liquid $v_f$	Sat. Vapor $v_g$	Sat. Liquid $u_f$	Evap. $u_{fg}$	Sat. Vapor $u_g$	Sat. Liquid $h_f$	Evap. $h_{fg}$	Sat. Vapor $h_g$	Sat. Liquid $s_f$	Evap. $s_{fg}$	Sat. Vapor $s_g$
2000	212.38	0.001177	0.099587	906.12	1693.0	2599.1	908.47	1889.8	2798.3	2.4467	3.8923	6.3390
2250	218.41	0.001187	0.088717	933.54	1667.3	2600.9	936.21	1864.3	2800.5	2.5029	3.7926	6.2954
2500	223.95	0.001197	0.079952	958.87	1643.2	2602.1	961.87	1840.1	2801.9	2.5542	3.7016	6.2558
3000	233.85	0.001217	0.066667	1004.6	1598.5	2603.2	1008.3	1794.9	2803.2	2.6454	3.5402	6.1856
3500	242.56	0.001235	0.057061	1045.4	1557.6	2603.0	1049.7	1753.0	2802.7	2.7253	3.3991	6.1244
4000	250.35	0.001252	0.049779	1082.4	1519.3	2601.7	1087.4	1713.5	2800.8	2.7966	3.2731	6.0696
5000	263.94	0.001286	0.039448	1148.1	1448.9	2597.0	1154.5	1639.7	2794.2	2.9207	3.0530	5.9737
6000	275.59	0.001319	0.032449	1205.8	1384.1	2589.9	1213.8	1570.9	2784.6	3.0275	2.8627	5.8902
7000	285.83	0.001352	0.027378	1258.0	1323.0	2581.0	1267.5	1505.2	2772.6	3.1220	2.6927	5.8148
8000	295.01	0.001384	0.023525	1306.0	1264.5	2570.5	1317.1	1441.6	2758.7	3.2077	2.5373	5.7450
9000	303.35	0.001418	0.020489	1350.9	1207.6	2558.5	1363.7	1379.3	2742.9	3.2866	2.3925	5.6791
10,000	311.00	0.001452	0.018028	1393.3	1151.8	2545.2	1407.8	1317.6	2725.5	3.3603	2.2556	5.6159
11,000	318.08	0.001488	0.015988	1433.9	1096.6	2530.4	1450.2	1256.1	2706.3	3.4299	2.1245	5.5544
12,000	324.68	0.001526	0.014264	1473.0	1041.3	2514.3	1491.3	1194.1	2685.4	3.4964	1.9975	5.4939
13,000	330.85	0.001566	0.012781	1511.0	985.5	2496.6	1531.4	1131.3	2662.7	3.5606	1.8730	5.4336
14,000	336.67	0.001610	0.011487	1548.4	928.7	2477.1	1571.0	1067.0	2637.9	3.6232	1.7497	5.3728
15,000	342.16	0.001657	0.010341	1585.5	870.3	2455.7	1610.3	1000.5	2610.8	3.6848	1.6261	5.3108
16,000	347.36	0.001710	0.009312	1622.6	809.4	2432.0	1649.9	931.1	2581.0	3.7461	1.5005	5.2466
17,000	352.29	0.001770	0.008374	1660.2	745.1	2405.4	1690.3	857.4	2547.7	3.8082	1.3709	5.1791
18,000	356.99	0.001840	0.007504	1699.1	675.9	2375.0	1732.2	777.8	2510.0	3.8720	1.2343	5.1064
19,000	361.47	0.001926	0.006677	1740.3	598.9	2339.2	1776.8	689.2	2466.0	3.9396	1.0860	5.0256
20,000	365.75	0.002038	0.005862	1785.8	509.0	2294.8	1826.6	585.5	2412.1	4.0146	0.9164	4.9310
21,000	369.83	0.002207	0.004994	1841.6	391.9	2233.5	1888.0	450.4	2338.4	4.1071	0.7005	4.8076
22,000	373.71	0.002703	0.003644	1951.7	140.8	2092.4	2011.1	161.5	2172.6	4.2942	0.2496	4.5439
22,064	373.95	0.003106	0.003106	2015.7	0	2015.7	2084.3	0	2084.3	4.4070	0	4.4070

TABLE A.2–3 Superheated Steam

T °C	$v$	$u$	$h$	$s$	$v$	$u$	$h$	$s$	$v$	$u$	$h$	$s$
	m <sup>3</sup> /kg	kJ/kg	kJ/kg	kJ/kg-K	m <sup>3</sup> /kg	kJ/kg	kJ/kg	kJ/kg-K	m <sup>3</sup> /kg	kJ/kg	kJ/kg	kJ/kg-K
	$P = 0.01$ MPa (45.81°C) <sup>*</sup>				$P = 0.05$ MPa (81.32 °C)				$P = 0.10$ MPa (99.61°C)			
Sat. <sup>†</sup>	14.670	2437.2	2583.9	8.1488	3.2403	2483.2	2645.2	7.5931	1.6941	2505.6	2675.0	7.3589
50	14.867	2443.3	2592.0	8.1741								
100	17.196	2515.5	2687.5	8.4489	3.4187	2511.5	2682.4	7.6953	1.6959	2506.2	2675.8	7.3611
150	19.513	2587.9	2783.0	8.6893	3.8897	2585.7	2780.2	7.9413	1.9367	2582.9	2776.6	7.6148
200	21.826	2661.4	2879.6	8.9049	4.3562	2660.0	2877.8	8.1592	2.1724	2658.2	2875.5	7.8356
250	24.136	2736.1	2977.5	9.1015	4.8206	2735.1	2976.2	8.3568	2.4062	2733.9	2974.5	8.0346

T °C	v m <sup>3</sup> /kg	u kJ/kg	h kJ/kg	s kJ/kg-K	v m <sup>3</sup> /kg	u kJ/kg	h kJ/kg	s kJ/kg-K	v m <sup>3</sup> /kg	u kJ/kg	h kJ/kg	s kJ/kg-K
<b>P = 0.01 MPa (45.81°C)</b>					<b>P = 0.05 MPa (81.32 °C)</b>				<b>P = 0.10 MPa (99.61°C)</b>			
300	26.446	2812.3	3076.7	9.2827	5.2841	2811.6	3075.8	8.5387	2.6389	2810.7	3074.5	8.2172
400	31.063	2969.3	3280.0	9.6094	6.2094	2968.9	3279.3	8.8659	3.1027	2968.3	3278.6	8.5452
500	35.680	3132.9	3489.7	9.8998	7.1338	3132.6	3489.3	9.1566	3.5655	3132.2	3488.7	8.8362
600	40.296	3303.3	3706.3	10.1631	8.0577	3303.1	3706.0	9.4201	4.0279	3302.8	3705.6	9.0999
700	44.911	3480.8	3929.9	10.4056	8.9813	3480.6	3929.7	9.6626	4.4900	3480.4	3929.4	9.3424
800	49.527	3665.4	4160.6	10.6312	9.9047	3665.2	4160.4	9.8883	4.9519	3665.0	4160.2	9.5682
900	54.143	3856.9	4398.3	10.8429	10.8280	3856.8	4398.2	10.1000	5.4137	3856.7	4398.0	9.7800
1000	58.758	4055.3	4642.8	11.0429	11.7513	4055.2	4642.7	10.3000	5.8755	4055.0	4642.6	9.9800
1100	63.373	4260.0	4893.8	11.2326	12.6745	4259.9	4893.7	10.4897	6.3372	4259.8	4893.6	10.1698
1200	67.989	4470.9	5150.8	11.4132	13.5977	4470.8	5150.7	10.6704	6.7988	4470.7	5150.6	10.3504
1300	72.604	4687.4	5413.4	11.5857	14.5209	4687.3	5413.3	10.8429	7.2605	4687.2	5413.3	10.5229
<b>P = 0.20 MPa (120.21°C)</b>					<b>P = 0.30 MPa (133.52°C)</b>				<b>P = 0.40 MPa (143.61°C)</b>			
Sat.	0.88578	2529.1	2706.3	7.1270	0.60582	2543.2	2724.9	6.9917	0.46242	2553.1	2738.1	6.8955
150	0.95986	2577.1	2769.1	7.2810	0.63402	2571.0	2761.2	7.0792	0.47088	2564.4	2752.8	6.9306
200	1.08049	2654.6	2870.7	7.5081	0.71643	2651.0	2865.9	7.3132	0.53434	2647.2	2860.9	7.1723
250	1.19890	2731.4	2971.2	7.7100	0.79645	2728.9	2967.9	7.5180	0.59520	2726.4	2964.5	7.3804
300	1.31623	2808.8	3072.1	7.8941	0.87535	2807.0	3069.6	7.7037	0.65489	2805.1	3067.1	7.5677
400	1.54934	2967.2	3277.0	8.2236	1.03155	2966.0	3275.5	8.0347	0.77265	2964.9	3273.9	7.9003
500	1.78142	3131.4	3487.7	8.5153	1.18672	3130.6	3486.6	8.3271	0.88936	3129.8	3485.5	8.1933
600	2.01302	3302.2	3704.8	8.7793	1.34139	3301.6	3704.0	8.5915	1.00558	3301.0	3703.3	8.4580
700	2.24434	3479.9	3928.8	9.0221	1.49580	3479.5	3928.2	8.8345	1.12152	3479.0	3927.6	8.7012
800	2.47550	3664.7	4159.8	9.2479	1.65004	3664.3	4159.3	9.0605	1.23730	3663.9	4158.9	8.9274
900	2.70656	3856.3	4397.7	9.4598	1.80417	3856.0	4397.3	9.2725	1.35298	3855.7	4396.9	9.1394
1000	2.93755	4054.8	4642.3	9.6599	1.95824	4054.5	4642.0	9.4726	1.46859	4054.3	4641.7	9.3396
1100	3.16848	4259.6	4893.3	9.8497	2.11226	4259.4	4893.1	9.6624	1.58414	4259.2	4892.9	9.5295
1200	3.39938	4470.5	5150.4	10.0304	2.26624	4470.3	5150.2	9.8431	1.69966	4470.2	5150.0	9.7102
1300	3.63026	4687.1	5413.1	10.2029	2.42019	4686.9	5413.0	10.0157	1.81516	4686.7	5412.8	9.8828
<b>P = 0.50 MPa (151.83°C)</b>					<b>P = 0.60 MPa (158.83°C)</b>				<b>P = 0.80 MPa (170.41°C)</b>			
Sat.	0.37483	2560.7	2748.1	6.8207	0.31560	2566.8	2756.2	6.7593	0.24035	2576.0	2768.3	6.6616
200	0.42503	2643.3	2855.8	7.0610	0.35212	2639.4	2850.6	6.9683	0.26088	2631.1	2839.8	6.8177
250	0.47443	2723.8	2961.0	7.2725	0.39390	2721.2	2957.6	7.1833	0.29321	2715.9	2950.4	7.0402
300	0.52261	2803.3	3064.6	7.4614	0.43442	2801.4	3062.0	7.3740	0.32416	2797.5	3056.9	7.2345
350	0.57015	2883.0	3168.1	7.6346	0.47428	2881.6	3166.1	7.5481	0.35442	2878.6	3162.2	7.4107
400	0.61731	2963.7	3272.4	7.7956	0.51374	2962.5	3270.8	7.7097	0.38429	2960.2	3267.7	7.5735
500	0.71095	3129.0	3484.5	8.0893	0.59200	3128.2	3483.4	8.0041	0.44332	3126.6	3481.3	7.8692
600	0.80409	3300.4	3702.5	8.3544	0.66976	3299.8	3701.7	8.2695	0.50186	3298.7	3700.1	8.1354
700	0.89696	3478.6	3927.0	8.5978	0.74725	3478.1	3926.4	8.5132	0.56011	3477.2	3925.3	8.3794
800	0.98966	3663.6	4158.4	8.8240	0.82457	3663.2	4157.9	8.7395	0.61820	3662.5	4157.0	8.6061
900	1.08227	3855.4	4396.6	9.0362	0.90179	3855.1	4396.2	8.9518	0.67619	3854.5	4395.5	8.8185
1000	1.17480	4054.0	4641.4	9.2364	0.97893	4053.8	4641.1	9.1521	0.73411	4053.3	4640.5	9.0189

(Continued)

TABLE A.2-3 (Continued)

T °C	v m <sup>3</sup> /kg	u kJ/kg	h kJ/kg	s kJ/kg-K	v m <sup>3</sup> /kg	u kJ/kg	h kJ/kg	s kJ/kg-K	v m <sup>3</sup> /kg	u kJ/kg	h kJ/kg	s kJ/kg-K
P = 0.50 MPa (151.83°C)					P = 0.60 MPa (158.83°C)				P = 0.80 MPa (170.41°C)			
1100	1.26728	4259.0	4892.6	9.4263	1.05603	4258.8	4892.4	9.3420	0.79197	4258.3	4891.9	9.2090
1200	1.35972	4470.0	5149.8	9.6071	1.13309	4469.8	5149.6	9.5229	0.84980	4469.4	5149.3	9.3898
1300	1.45214	4686.6	5412.6	9.7797	1.21012	4686.4	5412.5	9.6955	0.90761	4686.1	5412.2	9.5625
P = 1.00 MPa (179.88°C)					P = 1.20 MPa (187.96°C)				P = 1.40 MPa (195.04°C)			
Sat.	0.19437	2582.8	2777.1	6.5850	0.16326	2587.8	2783.8	6.5217	0.14078	2591.8	2788.9	6.4675
200	0.20602	2622.3	2828.3	6.6956	0.16934	2612.9	2816.1	6.5909	0.14303	2602.7	2803.0	6.4975
250	0.23275	2710.4	2943.1	6.9265	0.19241	2704.7	2935.6	6.8313	0.16356	2698.9	2927.9	6.7488
300	0.25799	2793.7	3051.6	7.1246	0.21386	2789.7	3046.3	7.0335	0.18233	2785.7	3040.9	6.9553
350	0.28250	2875.7	3158.2	7.3029	0.23455	2872.7	3154.2	7.2139	0.20029	2869.7	3150.1	7.1379
400	0.30661	2957.9	3264.5	7.4670	0.25482	2955.5	3261.3	7.3793	0.21782	2953.1	3258.1	7.3046
500	0.35411	3125.0	3479.1	7.7642	0.29464	3123.4	3477.0	7.6779	0.25216	3121.8	3474.8	7.6047
600	0.40111	3297.5	3698.6	8.0311	0.33395	3296.3	3697.0	7.9456	0.28597	3295.1	3695.5	7.8730
700	0.44783	3476.3	3924.1	8.2755	0.37297	3475.3	3922.9	8.1904	0.31951	3474.4	3921.7	8.1183
800	0.49438	3661.7	4156.1	8.5024	0.41184	3661.0	4155.2	8.4176	0.35288	3660.3	4154.3	8.3458
900	0.54083	3853.9	4394.8	8.7150	0.45059	3853.3	4394.0	8.6303	0.38614	3852.7	4393.3	8.5587
1000	0.58721	4052.7	4640.0	8.9155	0.48928	4052.2	4639.4	8.8310	0.41933	4051.7	4638.8	8.7595
1100	0.63354	4257.9	4891.4	9.1057	0.52792	4257.5	4891.0	9.0212	0.45247	4257.0	4890.5	8.9497
1200	0.67983	4469.0	5148.9	9.2866	0.56652	4468.7	5148.5	9.2022	0.48558	4468.3	5148.1	9.1308
1300	0.72610	4685.8	5411.9	9.4593	0.60509	4685.5	5411.6	9.3750	0.51866	4685.1	5411.3	9.3036
P = 1.60 MPa (201.37°C)					P = 1.80 MPa (207.11°C)				P = 2.00 MPa (212.38°C)			
Sat.	0.12374	2594.8	2792.8	6.4200	0.11037	2597.3	2795.9	6.3775	0.09959	2599.1	2798.3	6.3390
225	0.13293	2645.1	2857.8	6.5537	0.11678	2637.0	2847.2	6.4825	0.10381	2628.5	2836.1	6.4160
250	0.14190	2692.9	2919.9	6.6753	0.12502	2686.7	2911.7	6.6088	0.11150	2680.3	2903.3	6.5475
300	0.15866	2781.6	3035.4	6.8864	0.14025	2777.4	3029.9	6.8246	0.12551	2773.2	3024.2	6.7684
350	0.17459	2866.6	3146.0	7.0713	0.15460	2863.6	3141.9	7.0120	0.13860	2860.5	3137.7	6.9583
400	0.19007	2950.8	3254.9	7.2394	0.16849	2948.3	3251.6	7.1814	0.15122	2945.9	3248.4	7.1292
500	0.22029	3120.1	3472.6	7.5410	0.19551	3118.5	3470.4	7.4845	0.17568	3116.9	3468.3	7.4337
600	0.24999	3293.9	3693.9	7.8101	0.22200	3292.7	3692.3	7.7543	0.19962	3291.5	3690.7	7.7043
700	0.27941	3473.5	3920.5	8.0558	0.24822	3472.6	3919.4	8.0005	0.22326	3471.7	3918.2	7.9509
800	0.30865	3659.5	4153.4	8.2834	0.27426	3658.8	4152.4	8.2234	0.24674	3658.0	4151.5	8.1791
900	0.33780	3852.1	4392.6	8.4965	0.30020	3851.5	4391.9	8.4417	0.27012	3850.9	4391.1	8.3925
1000	0.36687	4051.2	4638.2	8.6974	0.32606	4050.7	4637.6	8.6427	0.29342	4050.2	4637.1	8.5936
1100	0.39589	4256.6	4890.0	8.8878	0.35188	4256.2	4889.6	8.8331	0.31667	4255.7	4889.1	8.7842
1200	0.42488	4467.9	5147.7	9.0689	0.37766	4467.6	5147.3	9.0143	0.33989	4467.2	5147.0	8.9654
1300	0.45383	4684.8	5410.9	9.2418	0.40341	4684.5	5410.6	9.1872	0.36308	4684.2	5410.3	9.1384
P = 2.50 MPa (223.99°C)					P = 3.00 MPa (233.90°C)				P = 3.50 MPa (242.60°C)			
Sat.	0.07998	2603.1	2803.1	6.2575	0.06668	2604.1	2804.2	6.1869	0.05707	2603.7	2803.4	6.1253
225	0.08027	2605.6	2806.3	6.2639	0.07058	2644.0	2855.8	6.2872	0.05872	2623.7	2829.2	6.1749
250	0.08700	2662.6	2880.1	6.4085	0.08114	2750.1	2993.5	6.5390	0.06842	2738.0	2977.5	6.4461
300	0.09890	2761.6	3008.8	6.6438	0.09053	2843.7	3115.3	6.7428	0.07678	2835.3	3104.0	6.6579

T °C	v m <sup>3</sup> /kg	u kJ/kg	h kJ/kg	s kJ/kg-K	v m <sup>3</sup> /kg	u kJ/kg	h kJ/kg	s kJ/kg-K	v m <sup>3</sup> /kg	u kJ/kg	h kJ/kg	s kJ/kg-K
P = 2.50 MPa (223.99°C)				P = 3.00 MPa (233.90°C)				P = 3.50 MPa (242.60°C)				
400	0.12010	2939.1	3239.3	7.0148	0.09936	2932.8	3230.9	6.9212	0.08453	2926.4	3222.3	6.8405
450	0.13014	3025.5	3350.8	7.1746	0.10787	3020.4	3344.0	7.0834	0.09196	3015.3	3337.2	7.0052
500	0.13993	3112.1	3462.1	7.3234	0.11619	3108.0	3456.5	7.2338	0.09918	3103.0	3450.9	7.1572
600	0.15930	3288.0	3686.3	7.5960	0.13243	3285.0	3682.3	7.5085	0.11324	3282.1	3678.4	7.4339
700	0.17832	3468.7	3914.5	7.8435	0.14838	3466.5	3911.7	7.7571	0.12699	3464.3	3908.8	7.6837
800	0.19716	3655.3	4148.2	8.0720	0.16414	3653.5	4145.9	7.9862	0.14056	3651.8	4143.7	7.9134
900	0.21590	3847.9	4387.6	8.2853	0.17980	3846.5	4385.9	8.1999	0.15402	3845.0	4384.1	8.1276
1000	0.2346	4046.7	4633.1	8.4861	0.19541	4045.4	4631.6	8.4009	0.16743	4044.1	4630.1	8.3288
1100	0.2532	4251.5	4884.6	8.6762	0.21098	4250.3	4883.3	8.5912	0.18080	4249.2	4881.9	8.5192
1200	0.2718	4462.1	5141.7	8.8569	0.22652	4460.9	5140.5	8.7720	0.19415	4459.8	5139.3	8.7000
1300	0.2905	4677.8	5404.0	9.0291	0.24206	4676.6	5402.8	8.9442	0.20749	4675.5	5401.7	8.8723
P = 4.0 MPa (250.35°C)				P = 4.5 MPa (257.44°C)				P = 5.0 MPa (263.94°C)				
Sat.	0.04978	2601.7	2800.8	6.0696	0.04406	2599.7	2798.0	6.0198	0.03945	2597.0	2794.2	5.9737
275	0.05461	2668.9	2887.3	6.2312	0.04733	2651.4	2864.4	6.1429	0.04144	2632.3	2839.5	6.0571
300	0.05887	2726.2	2961.7	6.3639	0.05138	2713.0	2944.2	6.2854	0.04535	2699.0	2925.7	6.2111
350	0.06647	2827.4	3093.3	6.5843	0.05842	2818.6	3081.5	6.5153	0.05197	2809.5	3069.3	6.4516
400	0.07343	2920.8	3214.5	6.7714	0.06477	2914.2	3205.7	6.7071	0.05784	2907.5	3196.7	6.6483
450	0.08004	3011.0	3331.2	6.9386	0.07076	3005.8	3324.2	6.8770	0.06332	3000.6	3317.2	6.8210
500	0.08644	3100.3	3446.0	7.0922	0.07652	3096.0	3440.4	7.0323	0.06858	3091.8	3434.7	6.9781
600	0.09886	3279.4	3674.9	7.3706	0.08766	3276.4	3670.9	7.3127	0.07870	3273.3	3666.9	7.2605
700	0.11098	3462.4	3906.3	7.6214	0.09850	3460.0	3903.3	7.5647	0.08852	3457.7	3900.3	7.5136
800	0.12292	3650.6	4142.3	7.8523	0.10916	3648.8	4140.0	7.7962	0.09816	3646.9	4137.7	7.7458
900	0.13476	3844.8	4383.9	8.0675	0.11972	3843.3	4382.1	8.0118	0.10769	3841.8	4380.2	7.9619
1000	0.14653	4045.1	4631.2	8.2698	0.13020	4043.9	4629.8	8.2144	0.11715	4042.6	4628.3	8.1648
1100	0.15824	4251.4	4884.4	8.4612	0.14064	4250.4	4883.2	8.4060	0.12655	4249.3	4882.1	8.3566
1200	0.16992	4463.5	5143.2	8.6430	0.15103	4462.6	5142.2	8.5880	0.13592	4461.6	5141.3	8.5388
1300	0.18157	4680.9	5407.2	8.8164	0.16140	4680.1	5406.5	8.7616	0.14527	4679.3	5405.7	8.7124
P = 6.0 MPa (275.59°C)				P = 7.0 MPa (285.83°C)				P = 8.0 MPa (295.01°C)				
Sat.	0.03245	2589.9	2784.6	5.8902	0.027378	2581.0	2772.6	5.8148	0.023525	2570.5	2758.7	5.7450
300	0.03619	2668.4	2885.6	6.0703	0.029492	2633.5	2839.9	5.9337	0.024279	2592.3	2786.5	5.7937
350	0.04225	2790.4	3043.9	6.3357	0.035262	2770.1	3016.9	6.2305	0.029975	2748.3	2988.1	6.1321
400	0.04742	2893.7	3178.3	6.5432	0.039958	2879.5	3159.2	6.4502	0.034344	2864.6	3139.4	6.3658
450	0.05217	2989.9	3302.9	6.7219	0.044187	2979.0	3288.3	6.6353	0.038194	2967.8	3273.3	6.5579
500	0.05667	3083.1	3423.1	6.8826	0.048157	3074.3	3411.4	6.8000	0.041767	3065.4	3399.5	6.7266
550	0.06102	3175.2	3541.3	7.0308	0.051966	3167.9	3531.6	6.9507	0.045172	3160.5	3521.8	6.8800
600	0.06527	3267.2	3658.8	7.1693	0.055665	3261.0	3650.6	7.0910	0.048463	3254.7	3642.4	7.0221
700	0.07355	3453.0	3894.3	7.4247	0.062850	3448.3	3888.3	7.3487	0.054829	3443.6	3882.2	7.2822
800	0.08165	3643.2	4133.1	7.6582	0.069856	3639.5	4128.5	7.5836	0.061011	3635.7	4123.8	7.5185
900	0.08964	3838.8	4376.6	7.8751	0.076750	3835.7	4373.0	7.8014	0.067082	3832.7	4369.3	7.7372
1000	0.09756	4040.1	4625.4	8.0786	0.083571	4037.5	4622.5	8.0055	0.073079	4035.0	4619.6	7.9419
1100	0.10543	4247.1	4879.7	8.2709	0.090341	4245.0	4877.4	8.1982	0.079025	4242.8	4875.0	8.1350
1200	0.11326	4459.8	5139.4	8.4534	0.097075	4457.9	5137.4	8.3810	0.084934	4456.1	5135.5	8.3181
1300	0.12107	4677.7	5404.1	8.6273	0.103781	4676.1	5402.6	8.5551	0.090817	4674.5	5401.0	8.4925

(Continued)



TABLE A.2-3 (Continued)

T °C	v m <sup>3</sup> /kg	u kJ/kg	h kJ/kg	s kJ/kg-K	v m <sup>3</sup> /kg	u kJ/kg	h kJ/kg	s kJ/kg-K	v m <sup>3</sup> /kg	u kJ/kg	h kJ/kg	s kJ/kg-K
P = 9.0 MPa (303.35°C)				P = 10.0 MPa (311.00°C)				P = 12.5 MPa (327.81°C)				
Sat.	0.020489	2558.5	2742.9	5.6791	0.018028	2545.2	2725.5	5.6159	0.013496	2505.6	2674.3	5.4638
325	0.023284	2647.6	2857.1	5.8738	0.019877	2611.6	2810.3	5.7596				
350	0.025816	2725.0	2957.3	6.0380	0.022440	2699.6	2924.0	5.9460	0.016138	2624.9	2826.6	5.7130
400	0.029960	2849.2	3118.8	6.2876	0.026436	2833.1	3097.5	6.2141	0.020030	2789.6	3040.0	6.0433
450	0.033524	2956.3	3258.0	6.4872	0.029782	2944.5	3242.4	6.4219	0.023019	2913.7	3201.5	6.2749
500	0.036793	3056.3	3387.4	6.6603	0.032811	3047.0	3375.1	6.5995	0.025630	3023.2	3343.6	6.4651
550	0.039885	3153.0	3512.0	6.8164	0.035655	3145.4	3502.0	6.7585	0.028033	3126.1	3476.5	6.6317
600	0.042861	3248.4	3634.1	6.9605	0.038378	3242.0	3625.8	6.9045	0.030306	3225.8	3604.6	6.7828
650	0.045755	3343.4	3755.2	7.0954	0.041018	3338.0	3748.1	7.0408	0.032491	3324.1	3730.2	6.9227
700	0.048589	3438.8	3876.1	7.2229	0.043597	3434.0	3870.0	7.1693	0.034612	3422.0	3854.6	7.0540
800	0.054132	3632.0	4119.2	7.4606	0.048629	3628.2	4114.5	7.4085	0.038724	3618.8	4102.8	7.2967
900	0.059562	3829.6	4365.7	7.6802	0.053547	3826.5	4362.0	7.6290	0.042720	3818.9	4352.9	7.5195
1000	0.064919	4032.4	4616.7	7.8855	0.058391	4029.9	4613.8	7.8349	0.046641	4023.5	4606.5	7.7269
1100	0.070224	4240.7	4872.7	8.0791	0.063183	4238.5	4870.3	8.0289	0.050510	4233.1	4864.5	7.9220
1200	0.075492	4454.2	5133.6	8.2625	0.067938	4452.4	5131.7	8.2126	0.054342	4447.7	5127.0	8.1065
1300	0.080733	4672.9	5399.5	8.4371	0.072667	4671.3	5398.0	8.3874	0.058147	4667.3	5394.1	8.2819
P = 15.0 MPa (342.16°C)				P = 17.5 MPa (354.67°C)				P = 20.0 MPa (365.75°C)				
Sat.	0.010341	2455.7	2610.8	5.3108	0.007932	2390.7	2529.5	5.1435	0.005862	2294.8	2412.1	4.9310
350	0.011481	2520.9	2693.1	5.4438								
400	0.015671	2740.6	2975.7	5.8819	0.012463	2684.3	2902.4	5.7211	0.009950	2617.9	2816.9	5.5526
450	0.018477	2880.8	3157.9	6.1434	0.015204	2845.4	3111.4	6.0212	0.012721	2807.3	3061.7	5.9043
500	0.020828	2998.4	3310.8	6.3480	0.017385	2972.4	3276.7	6.2424	0.014793	2945.3	3241.2	6.1446
550	0.022945	3106.2	3450.4	6.5230	0.019305	3085.8	3423.6	6.4266	0.016571	3064.7	3396.2	6.3390
600	0.024921	3209.3	3583.1	6.6796	0.021073	3192.5	3561.3	6.5890	0.018185	3175.3	3539.0	6.5075
650	0.026804	3310.1	3712.1	6.8233	0.022742	3295.8	3693.8	6.7366	0.019695	3281.4	3675.3	6.6593
700	0.028621	3409.8	3839.1	6.9573	0.024342	3397.5	3823.5	6.8735	0.021134	3385.1	3807.8	6.7991
800	0.032121	3609.3	4091.1	7.2037	0.027405	3599.7	4079.3	7.1237	0.023870	3590.1	4067.5	7.0531
900	0.035503	3811.2	4343.7	7.4288	0.030348	3803.5	4334.6	7.3511	0.026484	3795.7	4325.4	7.2829
1000	0.038808	4017.1	4599.2	7.6378	0.033215	4010.7	4592.0	7.5616	0.029020	4004.3	4584.7	7.4950
1100	0.042062	4227.7	4858.6	7.8339	0.036029	4222.3	4852.8	7.7588	0.031504	4216.9	4847.0	7.6933
1200	0.045279	4443.1	5122.3	8.0192	0.038806	4438.5	5117.6	7.9449	0.033952	4433.8	5112.9	7.8802
1300	0.048469	4663.3	5390.3	8.1952	0.041556	4659.2	5386.5	8.1215	0.036371	4655.2	5382.7	8.0574
P = 25.0 MPa				P = 30.0 MPa				P = 35.0 MPa				
375	0.001978	1799.9	1849.4	4.0345	0.001792	1738.1	1791.9	3.9313	0.001701	1702.8	1762.4	3.8724
400	0.006005	2428.5	2578.7	5.1400	0.002798	2068.9	2152.8	4.4758	0.002105	1914.9	1988.6	4.2144
425	0.007886	2607.8	2805.0	5.4708	0.005299	2452.9	2611.8	5.1473	0.003434	2253.3	2373.5	4.7751
450	0.009176	2721.2	2950.6	5.6759	0.006737	2618.9	2821.0	5.4422	0.004957	2497.5	2671.0	5.1946
500	0.011143	2887.3	3165.9	5.9643	0.008691	2824.0	3084.8	5.7956	0.006933	2755.3	2997.9	5.6331
550	0.012736	3020.8	3339.2	6.1816	0.010175	2974.5	3279.7	6.0403	0.008348	2925.8	3218.0	5.9093
600	0.014140	3140.0	3493.5	6.3637	0.011445	3103.4	3446.8	6.2373	0.009523	3065.6	3399.0	6.1229
650	0.015430	3251.9	3637.7	6.5243	0.012590	3221.7	3599.4	6.4074	0.010565	3190.9	3560.7	6.3030
700	0.016643	3359.9	3776.0	6.6702	0.013654	3334.3	3743.9	6.5599	0.011523	3308.3	3711.6	6.4623
800	0.018922	3570.7	4043.8	6.9322	0.015628	3551.2	4020.0	6.8301	0.013278	3531.6	3996.3	6.7409

T °C	v m <sup>3</sup> /kg	u kJ/kg	h kJ/kg	s kJ/kg-K	v m <sup>3</sup> /kg	u kJ/kg	h kJ/kg	s kJ/kg-K	v m <sup>3</sup> /kg	u kJ/kg	h kJ/kg	s kJ/kg-K
P = 25.0 MPa				P = 30.0 MPa				P = 35.0 MPa				
900	0.021075	3780.2	4307.1	7.1668	0.017473	3764.6	4288.8	7.0695	0.014904	3749.0	4270.6	6.9853
1000	0.023150	3991.5	4570.2	7.3821	0.019240	3978.6	4555.8	7.2880	0.016450	3965.8	4541.5	7.2069
1100	0.025172	4206.1	4835.4	7.5825	0.020954	4195.2	4823.9	7.4906	0.017942	4184.4	4812.4	7.4118
1200	0.027157	4424.6	5103.5	7.7710	0.022630	4415.3	5094.2	7.6807	0.019398	4406.1	5085.0	7.6034
1300	0.029115	4647.2	5375.1	7.9494	0.024279	4639.2	5367.6	7.8602	0.020827	4631.2	5360.2	7.7841
P = 40.0 MPa				P = 50.0 MPa				P = 60.0 MPa				
375	0.001641	1677.0	1742.6	3.8290	0.001560	1638.6	1716.6	3.7642	0.001503	1609.7	1699.9	3.7149
400	0.001911	1855.0	1931.4	4.1145	0.001731	1787.8	1874.4	4.0029	0.001633	1745.2	1843.2	3.9317
425	0.002538	2097.5	2199.0	4.5044	0.002009	1960.3	2060.7	4.2746	0.001816	1892.9	2001.8	4.1630
450	0.003692	2364.2	2511.8	4.9449	0.002487	2160.3	2284.7	4.5896	0.002086	2055.1	2180.2	4.4140
500	0.005623	2681.6	2906.5	5.4744	0.003890	2528.1	2722.6	5.1762	0.002952	2393.2	2570.3	4.9356
550	0.006985	2875.1	3154.4	5.7857	0.005118	2769.5	3025.4	5.5563	0.003955	2664.6	2901.9	5.3517
600	0.008089	3026.8	3350.4	6.0170	0.006108	2947.1	3252.6	5.8245	0.004833	2866.8	3156.8	5.6527
650	0.009053	3159.5	3521.6	6.2078	0.006957	3095.6	3443.5	6.0373	0.005591	3031.3	3366.8	5.8367
700	0.009930	3282.0	3679.2	6.3740	0.007717	3228.7	3614.6	6.2179	0.006265	3175.4	3551.3	6.0814
800	0.011521	3511.8	3972.6	6.6613	0.009073	3472.2	3925.8	6.5225	0.007456	3432.6	3880.0	6.4033
900	0.012980	3733.3	4252.5	6.9107	0.010296	3702.0	4216.8	6.7819	0.008519	3670.9	4182.1	6.6725
1000	0.014360	3952.9	4527.3	7.1355	0.011441	3927.4	4499.4	7.0131	0.009504	3902.0	4472.2	6.9099
1100	0.015686	4173.7	4801.1	7.3425	0.012534	4152.2	4778.9	7.2244	0.010439	4130.9	4757.3	7.1255
1200	0.016976	4396.9	5075.9	7.5357	0.013590	4378.6	5058.1	7.4207	0.011339	4360.5	5040.8	7.3248
1300	0.018239	4623.3	5352.8	7.7175	0.014620	4607.5	5338.5	7.6048	0.012213	4591.8	5324.5	7.5111

\*The temperature in parentheses is the saturation temperature at the specified pressure.  
Properties of saturated vapor at the specified pressure.

TABLE A.2-4 Compressed Liquid Water

T °C	v m <sup>3</sup> /kg	u kJ/kg	h kJ/kg	s kJ/kg-K	v m <sup>3</sup> /kg	u kJ/kg	h kJ/kg	s kJ/kg-K	v m <sup>3</sup> /kg	u kJ/kg	h kJ/kg	s kJ/kg-K
P = 5 MPa (263.94°C)				P = 10 MPa (311.00°C)				P = 15 MPa (342.16°C)				
Sat.	0.0012862	1148.1	1154.5	2.9207	0.0014522	1393.3	1407.9	3.3603	0.0016572	1585.5	1610.3	3.6848
0	0.0009977	0.04	5.03	0.0001	0.0009952	0.12	10.07	0.0003	0.0009928	0.18	15.07	0.0004
20	0.0009996	83.61	88.61	0.2954	0.0009973	83.31	93.28	0.2943	0.0009951	83.01	97.93	0.2932
40	0.0010057	166.92	171.95	0.5705	0.0010035	166.33	176.37	0.5685	0.0010013	165.75	180.77	0.5666
60	0.0010149	250.29	255.36	0.8287	0.0010127	249.43	259.55	0.8260	0.0010105	248.58	263.74	0.8234
80	0.0010267	333.82	338.96	1.0723	0.0010244	332.69	342.94	1.0691	0.0010221	331.59	346.92	1.0659
100	0.0010410	417.65	422.85	1.3034	0.0010385	416.23	426.62	1.2996	0.0010361	414.85	430.39	1.2958
120	0.0010576	501.91	507.19	1.5236	0.0010549	500.18	510.73	1.5191	0.0010522	498.50	514.28	1.5148
140	0.0010769	586.80	592.18	1.7344	0.0010738	584.72	595.45	1.7293	0.0010708	582.69	598.75	1.7243
160	0.0010988	672.55	678.04	1.9374	0.0010954	670.06	681.01	1.9316	0.0010920	667.63	684.01	1.9259
180	0.0011240	759.47	765.09	2.1338	0.0011200	756.48	767.68	2.1271	0.0011160	753.58	770.32	2.1205
200	0.0011531	847.92	853.68	2.3251	0.0011482	844.32	855.80	2.3174	0.0011435	840.84	858.00	2.3100
220	0.0011868	938.39	944.32	2.5127	0.0011809	934.01	945.82	2.5037	0.0011752	929.81	947.43	2.4951

(Continued)

TABLE A.2-4 (Continued)

T °C	v m <sup>3</sup> /kg	u kJ/kg	h kJ/kg	s kJ/kg-K	v m <sup>3</sup> /kg	u kJ/kg	h kJ/kg	s kJ/kg-K	v m <sup>3</sup> /kg	u kJ/kg	h kJ/kg	s kJ/kg-K
P = 5 MPa (263.94°C)					P = 10 MPa (311.00°C)				P = 15 MPa (342.16°C)			
240	0.0012268	1031.6	1037.7	2.6983	0.0012192	1026.2	1038.3	2.6876	0.0012121	1021.0	1039.2	2.6774
260	0.0012755	1128.5	1134.9	2.8841	0.0012653	1121.6	1134.3	2.8710	0.0012560	1115.1	1134.0	2.8586
280					0.0013226	1221.8	1235.0	3.0565	0.0013096	1213.4	1233.0	3.0410
300					0.0013980	1329.4	1343.3	3.2488	0.0013783	1317.6	1338.3	3.2279
320									0.0014733	1431.9	1454.0	3.4263
340									0.0016311	1567.9	1592.4	3.6555
P = 20 MPa (365.75°C)					P = 30 MPa				P = 50 MPa			
Sat.	0.0020378	1785.8	1826.6	4.0146								
0	0.0009904	0.23	20.03	0.0005	0.0009857	0.29	29.86	0.0003	0.0009767	0.29	49.13	0.0010
20	0.0009929	82.71	102.57	0.2921	0.0009886	82.11	111.77	0.2897	0.0009805	80.93	129.95	0.2845
40	0.0009992	165.17	185.16	0.5646	0.0009951	164.05	193.90	0.5607	0.0009872	161.90	211.25	0.5528
60	0.0010084	247.75	267.92	0.8208	0.0010042	246.14	276.26	0.8156	0.0009962	243.08	292.88	0.8055
80	0.0010199	330.50	350.90	1.0627	0.0010155	328.40	358.86	1.0564	0.0010072	324.42	374.78	1.0442
100	0.0010337	413.50	434.17	1.2920	0.0010290	410.87	441.74	1.2847	0.0010201	405.94	456.94	1.2705
120	0.0010496	496.85	517.84	1.5105	0.0010445	493.66	525.00	1.5020	0.0010349	487.69	539.43	1.4859
140	0.0010679	580.71	602.07	1.7194	0.0010623	576.90	608.76	1.7098	0.0010517	569.77	622.36	1.6916
160	0.0010886	665.28	687.05	1.9203	0.0010823	660.74	693.21	1.9094	0.0010704	652.33	705.85	1.8889
180	0.0011122	750.78	773.02	2.1143	0.0011049	745.40	778.55	2.1020	0.0010914	735.49	790.06	2.0790
200	0.0011390	837.49	860.27	2.3027	0.0011304	831.11	865.02	2.2888	0.0011149	819.45	875.19	2.2628
220	0.0011697	925.77	949.16	2.4867	0.0011595	918.15	952.93	2.4707	0.0011412	904.39	961.45	2.4414
240	0.0012053	1016.1	1040.2	2.6676	0.0011927	1006.9	1042.7	2.6491	0.0011708	990.55	1049.1	2.6156
260	0.0012472	1109.0	1134.0	2.8469	0.0012314	1097.8	1134.7	2.8250	0.0012044	1078.2	1138.4	2.7864
280	0.0012978	1205.6	1231.5	3.0265	0.0012770	1191.5	1229.8	3.0001	0.0012430	1167.7	1229.9	2.9547
300	0.0013611	1307.2	1334.4	3.2091	0.0013322	1288.9	1328.9	3.1761	0.0012879	1259.6	1324.0	3.1218
320	0.0014450	1416.6	1445.5	3.3996	0.0014014	1391.7	1433.7	3.3558	0.0013409	1354.3	1421.4	3.2888
340	0.0015693	1540.2	1571.6	3.6086	0.0014932	1502.4	1547.1	3.5438	0.0014049	1452.9	1523.1	3.4575
360	0.0018248	1703.6	1740.1	3.8787	0.0016276	1626.8	1675.6	3.7499	0.0014848	1556.5	1630.7	3.6301
380					0.0018729	1782.0	1838.2	4.0026	0.0015884	1667.1	1746.5	3.8102

## A

abrasives, 524  
absolute pressure, 532  
absorption refrigeration cycle, 250  
actual Brayton cycle, 169–171  
adiabatic process, 15  
air compressors  
  classification of, 330–331  
  clearance on work done, 334–335  
  isentropic compression, 334  
  multistage compression, 337–339  
  polytropic compression, 333–334  
  reciprocating compressor, 331–333  
  volumetric efficiency of, 335  
air conditioning, 239  
air-fuel ratio, 210  
air injection system, 213–214  
air preheater, 126–127  
air-refrigeration system, 242–245  
  advantages and disadvantages, 245  
air vessel, 315–316  
air washers, 264  
alloying elements, 521–522  
alloy steel, 521  
aluminium alloys, 522  
angular contact bearings, 423–424  
annealing, 720  
anvil, 686–687  
apparatus dew-point (ADP) temperature, 257  
atomic hydrogen welding, 638–639  
austempering, 721  
automatic start/stop, 217  
automation, 696–698  
average stress, 378  
axial flow compressors, 345–346  
axial thrust, 150

## B

Babcock and Wilcox boiler, 115–116  
bakelite or resinoid bond, 588  
ball bearing, 422–426  
bar drawing, 666  
bearings  
  materials, 426–427  
  rolling contact, 422  
  sliding contact or bush, 421–422  
Bell–Coleman cycle, 243–244  
belt drives, 455–458  
  compound, 462–463  
  creep, 458  
  crossed, 460–461  
  effect of centrifugal force on, 465–466  
  flat, 458  
  open, 459–460  
  quarter turn drive, 461  
  ratio of tensions, 463–464  
  round belts, 456  
  timing belts or toothed belts, 457  
  V-belt, 456  
  velocity ratio, 457–458  
bending, 678  
Bernoulli's equation, 281–283, 537  
Betz limit, 89  
bevel gears, 477–478  
bimetallic devices, 530–531  
binary cycle power plants, 86–87  
bioalcohols, 63–64  
biodiesel, 64  
bioethers (oxygenated fuels), 65  
biofuels, 63–66  
biogas, 65  
biomass energy, 90–91  
blade efficiency, 151  
blade friction factor, 150  
blank diameter, 679  
blanking, 677–678  
boiler accessories, 125–129  
boiler efficiency, 130  
boiler mountings, 118–125  
  blow-off cock, 123–124

- feed check valve, 122
  - fusible plug, 124
  - high steam and low water safety valve, 120–121
  - manhole, 125
  - pressure gauge, 122
  - safety valves, 118–120
  - steam stop valve, 123
  - water level indicator, 121
  - boilers, 112–118
    - performance of, 129–130
  - boiling water reactor (BWR), 79
  - bomb calorimeter, 67–68
  - boring, 568–569
  - boring machine, 580
  - boundary of a system, 6
  - Bourdon tube pressure gauge, 533–534
  - Boyle's Law, 42, 44
  - brakes
    - band, 500–502
    - band and block, 503–504
    - internal expanding shoe, 504–506
    - shoe or block, 497–499
  - brake thermal efficiency, 209
  - Brayton cycle, 166–169
  - braze welding, 647
  - brazing, 646–647
  - Brinell hardness test, 516
  - bulk modulus, 397
  - bush bearing, 420
  - bushing, 420
    - lubrications in, 421
    - materials, 420
  - by-pass factor (BPF), 257
- C**
- cam and follower
    - nomenclature, 416–417
    - types of, 417–419
  - cantilever beam, 542
  - capillarity, 278–279
  - capillary depression, 278–279
  - capillary rise, 279
  - carbon arc welding, 633
  - carbon monoxide, 212
  - carburetor engine, 185, 215
  - carburizing, 722–723
  - Carnot corollaries, 33–34
  - Carnot cycle, 32–34
  - casting defects, 619–621
  - casting process, 597–598
    - classification of, 598
    - casting surface, cleaning of, 621–622
  - cast irons, 520
  - catalytic converter, 213
  - cavitation, 303
  - Celsius temperature, 7
  - Celsius temperature scale (centigrade scale), 6
  - centerless grinders, 591–592
  - centerless grinding, 589
  - center of gravity, 352–353
  - center of gravity of a solid, 363
  - center of mass, 352–353
  - centrifugal casting, 617–619
  - centrifugal compressors, 344–345
  - centrifugal pump, 304–308
  - centrifuging, 619
  - centroid, 352–353
    - of circular arc, 357
    - of C-section, 356
    - of H-section, 355
    - of I-section, 354
    - of L-section, 355–356
    - of a parabola, 358–359
    - of sector of a circular disc, 358
    - of semicircular-section of a disc, 357–358
    - of a triangle, 359–360
    - of T-section, 356
    - of U-section, 354–355
  - ceramics, 524–525
  - chain drive, 469–470
    - types of, 471–472
  - change in state, 4–5
  - change-of-state temperature sensors, 531
  - chaplets, 612
  - Charles's Law, 43–44
  - chemical equilibrium, 4
  - chills, 611–612
  - chisel edge angle, 577
  - chisels, 689–690
  - chlorofluorocarbons (CFCs), 212
  - chromium (Cr), 521
  - classical thermodynamics, 1
  - Clausius inequality, 34
  - Clausius statement, 29–30
    - violation of, 31–32
  - clay content test of sand mold, 614
  - close die forging, 661
  - closed system, 6
  - clutches
    - centrifugal clutch, 496
    - cone clutch, 494–495

multi-disc clutch, 493  
 single plate clutch, 488–490  
 coal, 56–58, 91  
   ash content, 58  
   grades of, 57  
   proximate analysis of, 57  
   sulfur content, 58  
   ultimate analysis of, 57  
 cochran boiler, 114–115  
 coining, 670  
 cold chamber die-casting, 616–617  
 combination set, 552–553  
 combustion, principle of, 66–67  
 combustion chamber, 214  
 common rail direct injection system (CRDI), 214, 216–217  
 Co<sub>2</sub> molds, 606  
 compacting, 683–684  
 compressed natural gas (CNG), 62  
 compressible and incompressible flow, 284  
 compression stroke, 189–190, 192  
 compressive test of sand mold, 614–615  
 compressor, 241  
 computer aided design (CAD), 698–699  
 computer aided manufacturing (CAM), 699–700  
 computer integrated manufacturing system (CIM), 698  
 computer numerical control (CNC), 701, 703  
 condenser, 242  
 condition line, 158  
 conduction, 225–226  
 conical and volute springs, 407  
 constructional detail of shaper, 570–571  
 continuous chip, 557  
   with a built-up (BUP) edge, 558  
 continuous path control robots, 708–709  
 control volume, 5–6  
 convection, 227–228  
 conveyor chain, 471  
 copper alloys, 522–523  
 cores, 612–613  
 core sand molds, 606  
 Cornish boiler, 118  
 crank and slotted arm mechanism, 571–572  
 creep feed grinding, 589  
 crude oil, 91  
 cutting-off/grooving, 566  
 cyaniding, 723  
 cylindrical grinders, 589–590  
 cylindrical grinding, 588  
 cylindrical or plain roller bearings, 425

## D

Dalton's law of partial pressure, 253  
 deep drawing, 678–680  
 deep-groove ball bearing, 423  
 degree of saturation, 253  
 dew point temperature (DPT), 254  
 dial gauge or dial indicator, 549  
 die-casting, 615–617  
 diesel, 59  
 Diesel cycle, 183, 190, 197, 203–204  
 diesel power plant, 80–82  
   advantages, 81  
   disadvantages, 81–82  
 direct numerical control (DNC), 703–704  
 discontinuous chip, 558  
 disc springs, 408–409  
 domestic or household refrigerator, 251–252  
 double helical / herringbone gears, 477  
 down milling, 582  
 drift, 690  
 drilling, 568  
 drilling machine  
   drill bit, 576–577  
   driving mechanism in, 575  
   operations performed on, 577–579  
   specifications of, 577  
 drop forging, 662  
 dry bulb temperature (DBT), 254  
 dryness fraction, 100  
 dry sand mold, 606  
 dry steam power plant, 85–86  
 dual cycle, 206–207

## E

eccentric turning, 565  
 economizer, 125–126  
 efficiency ratio, 210  
 electric arc welding, 629–632  
 electric motor drive/assist, 217  
 electro-hydraulic forming, 668  
 electroslag welding, 637–638  
 emission control, 212–214  
   techniques, 212–214  
 end milling, 583–584  
 energy transfer, 13  
 engine control unit (ECU), 216  
 engineering materials  
   allowable stress, 515  
   classification of, 519–522  
   elastic and plastic range, 514

- elastic limit, 514
- factor of safety, 515
- hardness, 515–518
- impact test, 518–519
- mechanical properties of, 512
- modulus of resilience, 514–515
- modulus of toughness, 515
- proportionality, 514
- rapture strength, 514
- stress-strain diagram, 513–514
- tensile test, 513
- ultimate strength, 514
- working stress, 515
- yield point, 514
- engineering thermodynamics, 1
- enthalpy, 7
- entropy, 34–35
  - balance, 35–36
  - change, 36
  - generation, 35
  - of steam, 101
  - of water, 100
- equilibrium, 4–5
- equivalent evaporation, 129
- ethanol, 64
- Euler's Equation of motion, 282–283
- evaporation rate, 129
- evaporator, 241
- exhaust gas recirculation valve (EGR) valve, 213
- exhaust stroke, 190, 192
- expansion valve, 242
- explosive forming, 667–668
- extensive properties, 4
- external fired boilers, 113
- extrusion, 663
  - cold, 664
  - hot, 664
  - impact, 664–665

**F**

- face grinding, 589
- face milling, 584
- facing operation, 565
- factor of evaporation, 129
- Fahrenheit scale, 7
- fast breeder reactor (FBR), 79
- fatty acid methyl esters (FAMES), 64
- feed pump, 127
- ferrous metals, 519–522
- fineness test of sand mold, 614

- finishing operations, 684
- fire tube boilers, 112–113
- first law of thermodynamics, 11
  - limitations, 28
- fixed vane type compressors, 342–343
- flash steam power plants, 86
- flash welding, 643–644
- flatters, 690
- flexible bushed coupling, 486–487
- flow measurement, 536–539
- fluid density
  - mass density, 274
  - relative density, 274
  - specific weight, 274
  - viscosity, 274–276
- fluid-expansion devices, 531
- fluid mechanics
  - properties of fluid, 273–281
  - types of flow, 284
- flywheel, 431–432
  - difference between governors and, 450
  - mass moment of inertia of, 432–433
- force measurement, 541–542
- forging, 660
  - different types of, 660–663
- formaldehyde, 212
- form grinding, 589
- form milling, 585
- fossil fuels, 55
- four-stroke compression ignition engine, 190–192
  - valve timing diagram, 199–200
- four-stroke spark ignition engine, 188–190
  - valve timing diagram, 197–198
- Francis turbine
  - components, 293–294
  - shapes of draft tubes, 294–296
- fuel injectors, 214
- fuels, 55
- fuel stratified injection (FSI), 216
- fullers, 690–691

**G**

- gang drilling machine, 579–580
- gang milling, 584
- gas carburizing, 722
- gas cooled reactor (GCR), 79
- gaseous fuels, 62–63
  - advantages and disadvantages of, 63
- gasoline, 60
- gasoline direct injection (GDI), 216

- gas turbine cycle
  - with regenerator, 175
  - with reheating and intercooling, 175–176
- gas turbines, 165
  - applications of, 165–171
  - classification of, 165
  - flow diagram of intercooling and reheating, 176
- gas welding, 625–628
- gauge factor (GF), 541
- gauge pressure, 531
- Gay–Lussac’s Law, 43–44
- gear drive, 472–474
  - forms of gear teeth, 475
- gear pump, 317–318
- geothermal energy, 91
- geothermal power plant, 85–87
- glasses, 525
- global warming, 56
- governing of turbines, 304
- governors, 434–435
  - centrifugal, 436
  - classification of, 436
  - difference between flywheel and, 450
  - Hartnell, 442–444
  - Hartung, 447
  - of I.C. engine, 449–450
  - inertia and flywheel, 436
  - pickering, 436
  - porter, 437–439
  - Proell, 440–441
  - sensitiveness of, 448
  - terms used in, 435
  - watt, 436–437
  - Willson–Hartnell, 445–446
- gravity/permanent mould casting, 615
- gray cast iron, 520
- green diesel, 64
- green sand mold, 605
- grinding machines, 586–592
- gross calorific value (GCV), 60
  
- H**
- hammers, 687–688
- hardening, 720
- hardness test of sand mold, 615
- heat
  - defined, 7
  - similarities between work and, 13
- heat exchanger, 86
- heat pumps, 240
- heat transfer, modes of
  - combined form, 229
  - conduction, 225–226
  - convection, 227–228
  - radiation, 228
  - through hollow cylinder, 232–233
  - through hollow sphere, 234
- heat treatment
  - annealing, 720
  - austempering, 721
  - carburizing, 722–723
  - cyaniding, 723
  - hardening, 720
  - induction hardening, 723
  - iron-carbon (Fe-C) phase diagram, 716–718
  - martempering, 721–722
  - nitriding, 723
  - normalizing, 719–720
  - spheroidizing, 720
  - tempering, 721–722
  - time-temperature-transformation curves, 718–719
- heavy water cooled and moderated CANDU  
(Canadian deuterium uranium) reactor, 79
- heel, 577
- helical gears, 476–477
- helical springs, 407
  - deflection in, 412–413
  - series connection and parallel connection of, 414–415
  - shear stress in, 410–412
- high carbon steel, 520
- high energy rate forming, 667
- hobbing, 670
- Hook’s law, 379, 513–514
- horizontal boiler, 113
- hot chamber die-casting, 616
- hot spinning, 680–681
- hot wire anemometer, 536
- human comfort conditions, 264–265
- humidity (*w*) ratio, 253
- hybrid engine, 217
- hydraulic machines, 284–285
- hydraulic pumps, 304
- hydraulic turbines, 285
  - classification of, 285
  - terminology used, 286
- hydrocarbon fuels, 55
- hydrocarbons, 59, 212
- hydroelectric power, 90
- hydroelectric power plant, 76
- hypoid gears, 478



**I**

ideal gas law, 45  
impulses-reaction turbine (reaction turbine),  
157–160  
degree of reaction (R) of, 158  
differences between impulse and, 164  
reheat factor, 158–159  
velocity diagram for, 159–160  
impulse turbine, 147–151  
compounding of, 153–157  
inclined boiler, 113  
indicated thermal efficiency, 209  
infeed or plunge cut grinding, 589  
infrared sensors, 530  
injector, 128  
intelligent robots, 709  
intensive properties, 4  
Internal Combustion Engine (I.C. Engine), 182  
arrangement of cylinders, 184  
basic structure, 185–188  
classification of, 183–185  
clearance volume ( $V_c$ ), 188  
comparison between four-stroke and two-stroke  
engines, 196  
comparison between S.I. and, 197  
compression ratio, 188  
cooling systems in, 184  
cylinder bore, 187  
dead centers, 187  
displacement volume, 187  
engine performance parameters, 209–210  
fuel supply systems, 184  
fuel used, 183  
ignition systems, 183  
nature of thermodynamic cycle, 183  
number of strokes per cycle, 183  
piston area, 187  
stroke or stroke length, 187–188  
working principle of, 188–196  
internal energy (U) of a system, 7, 11–12  
physical interpretation of, 12  
internal fired boilers, 113  
internal grinding, 588  
ion gauges, 535  
iron-carbon (Fe-C) phase diagram, 716–718  
irreversible process, 32  
isentropic compression, 334  
isobaric process, 14  
isochoric process, 14  
isolated system, 3  
isothermal process, 15

**J**

Joule cycle, 166–169

**K**

Kaplan turbine, 299–300  
Kelvin-Planck statement, 29  
violation of, 30–31  
Kelvin temperature, 7  
kerosene, 59  
knurling, 567

**L**

laminar and turbulent flow, 284  
laminated or leaf spring, 408–409  
Lancashire boiler, 117  
lancing, 678  
lateral strain, 378  
lathe  
classification, 559–560  
constructional detail of, 560–562  
cutting tools used in, 564  
power transmission system in, 562–564  
specification, 560  
types of operations in, 564–569  
law of gearing, 474  
lignite, 91  
limited sequence robots, 708  
liquefied petroleum gases (LPG), 62  
liquid fuels, 58–61  
advantage and disadvantage of, 61  
ash content, 61  
calorific value of, 60  
carbon residue in, 61  
sulfur content, 60  
water content of, 61  
liquid metal cooled reactor, 79  
load cell, 541–542  
loam sand molds, 606  
lobe pump, 318  
locomotive boiler, 116  
longitudinal strain, 378  
low carbon steel, 520

**M**

machine tools, 556  
macroscopic (classical thermodynamics), 2  
macroscopic forms of energy, 12  
magnesium alloys, 523  
malleable cast iron, 521  
manganese (Mn), 521  
manometers, 532–533

- manufacturing system  
 automation, 696–698  
 computer aided design (CAD), 698–699  
 computer aided manufacturing (CAM), 699–700  
 computer integrated manufacturing system (CIM), 698  
 computer numerical control (CNC), 701, 703  
 computer system, 696  
 direct numerical control (DNC), 703–704  
 human workers, 696  
 material handling system, 696  
 numerical control (NC), 700–701  
 production machines, tools, jigs, fixtures, 695–696  
 programming methods, 701–702
- martempering, 721–722
- mass, defined, 3
- mass moment of inertia  
 of circular cone, 366–367  
 of circular disc, 364–365  
 of circular ring, 363–364  
 of hollow cylinder, 365  
 of inertia of sphere, 365–366
- mean effective pressure, 210
- mean piston speed, 210
- measurement errors, 545
- mechanical efficiency, 210
- mechanical equilibrium, 4
- mechanical equivalent of heat, 10–11
- mechanical measurement, 529
- mechanical working, 655–656  
 advantages, 656–657  
 comparison between cold working and hot working, 656
- medium carbon steel, 520
- metal cutting, 557–558  
 orthogonal and oblique, 558–559
- metal inert gas arc welding (MIG)/gas metal arc welding (GMAW), 634–635
- metal molds, 606
- metal powders  
 blending/mixing of, 682  
 characteristics, 681  
 methods of production, 681–682
- methane emission, 212
- micrometer, 547–549
- microscopic forms of energy, 12
- microscopic (statistical thermodynamics), 2
- milling machines, 581–585
- modulus of elasticity, 397–398, 514
- modulus of rigidity, 397–398
- moisture content test of sand mold, 614
- Mollier diagram ( $h$ - $S$  chart), 111–112
- molybdenum (Mo), 522
- moment of inertia (second moment of area), 360  
 of a circular disc, 362  
 of composite sections, 363  
 of a rectangle, 361  
 of a triangle, 362
- multiple vane type compressors, 343–344
- multi-point fuel injection system (MPFI), 214–215
- multi-spindle drilling machine, 579–580
- N**
- natural circulation boilers, 113
- natural gas, 92
- needle bearings, 425–426
- net calorific value (NCV), 60
- Newtonian and non-Newtonian fluids, 276–277
- nickel (Ni), 521
- nitriding, 723
- nitrogen oxide, 212
- nodular (or ductile) cast iron, 520
- non-ferrous materials, 522–523
- non-flow processes, 14–15
- non-renewable energy, 91–93
- normalizing, 719–720
- normal stress, 378
- notching, 670, 678
- nuclear power, 92–93
- nuclear power plant, 76–79  
 block diagram of, 78  
 components of, 78
- numerical control (NC), 700–701, 703
- O**
- off hand grinding, 589
- oil spill accidents, 92
- open die forging, 660–661
- open system, 3, 6
- optimum velocity ratio, 151
- orificemeter, 538
- Otto cycle, 183, 190, 197, 200–201
- oxy-acetylene welding, 625–628
- oxychloride bond, 588
- P**
- pack carburizing, 722–723
- particulate matter, 212
- parting, 678

- peat, 91
  - Pelton turbine, 287–290
    - components, 287–288
    - speed of, 288–289
    - velocity triangle for, 289–290
  - percussion welding, 644
  - perforating, 678
  - peripheral milling, 582
  - permeability number, 614
  - permeability test of sand mold, 614
  - perpetual-motion machine of the first kind (PMM1), 30
  - perpetual-motion machine of the second kind (PMM2), 30
  - perpetual motion machine (PMM1), 11
  - petroleum, 58–59
  - phase, defined, 5
  - phase equilibrium, 5
  - phosphorus (P), 521
  - photovoltaic cells, 90
  - piercing, 677–678
  - piercing or seamless tubing, 669–670
  - Pirani gauge, 534
  - plain cylindrical grinders, 590
  - plane milling, 582
  - planer, 573
    - fast and loose pulleys driving mechanism of, 573–574
    - specifications of, 575
  - plane surface grinder, 590–591
  - plasma arc welding, 639–640
  - plastics, 523–524
  - point angle, 577
  - point-to-point (PTP) control robots, 708–709
  - Poisson strain, 540
  - polytropic compression, 333–334
  - polytropic process, 15–16
  - positive crankcase ventilation (PCV) system, 212–213
  - potential energy, 12
  - powder metallurgy, 681
    - advantages, 684–685
    - applications of, 685
    - disadvantages, 685
  - power plant engineering, 74–89
  - power stroke, 190, 192
  - power transmission, 455
  - power transmission chains, 471–472
  - precision grinders, 589
  - press forging, 662
  - pressure
    - defined, 3
    - equilibrium, 5
    - measurement, 531–535
    - reducing valve, 129
    - variation with depth of a fluid, 280–281
  - pressurized water reactor (PWR), 79
  - prime movers, 73–74
    - historical development of, 74
    - reciprocating, 74
    - rotating, 74
  - process, defined, 5
  - profile milling, 585
  - Prony brake, 543
  - property, defined, 4
  - psychrometric chart
    - cooling and dehumidification, 256–257
    - cooling and humidification, 258–259
    - heating and dehumidification, 259
    - heating and humidification, 257–258
    - mixing of air streams, 259–260
    - sensible cooling, 254–256
    - sensible heat factor (SHF), 257
    - sensible heating, 256
  - psychrometry, 253–254
  - punches, 690
  - punching, 677–678
  - pure biodiesel (B100), 64
  - P-V diagram for diesel cycle, 192
- Q**
- quasi static process, 6
- R**
- radial drilling machine, 579
  - radial rake angle, 585
  - radius of gyration of a body, 360
  - rake or helix angle, 577
  - Rankine scale, 7
  - reaming operation, 568
  - reciprocating prime movers, 74
  - reciprocating pump, 311–316
  - refining, 59
  - refractory metals, 523
  - refrigerants, 250–251
  - refrigeration, 239–240
    - capacity of refrigeration plant, 241
    - components of, 241–242
    - tons of, 240–241
  - regenerative braking system, 217
  - relative humidity, 253
  - relief angle, 585
  - renewable energy, 90–91
  - resin-bonded sand molds, 606

- resistance butt welding, 645
  - resistance projection welding, 642–643
  - resistance seam welding, 642
  - resistance spot welding, 641–642
  - resistance welding, 640
  - resistive temperature devices (RTD), 530
  - reversed Brayton cycle, 243–244
  - reversed Carnot cycle, 242–243
  - reversible adiabatic compression, 33
  - reversible adiabatic expansion, 33
  - reversible isothermal compression, 33
  - reversible isothermal expansion, 33
  - reversible process, 32
  - rigid couplings, 485–486
  - risers, 611
  - robotics, 704–709
    - applications, 712
    - configurations, 706–708
    - control systems, 709–712
    - microprocessor based controllers, 711
    - robotic control, 708–709
    - sensors used in, 711
    - sequential control, 711
    - transducers used in, 712
  - Rockwell hardness test, 517–518
  - roller bearings, 425
  - roll forming, 681
  - rolling mills, 657–659
    - defects, 659
    - types of, 658–659
  - room air conditioners, 265–267
  - rope brake dynamometer, 543–544
  - rope drive, 468–469
  - rotameter, 538–539
  - rotary compressors, 342–344
  - rotating prime movers, 74
  - rotational and irrotational flow, 284
  - rough grinders, 589
  - rubber bond, 588
- S**
- sand casting, 598–599
    - gating system, 610–611
    - hand tools for sand moulding, 608–609
    - methods, 615–619
    - moulding procedure, 609–610
    - mould making, 605–606
    - pattern making, 600–601
    - properties of mouldings sands, 607–608
    - steps in, 599–600
    - types of mold, 605–606
    - types of pattern, 601–605
  - sand testing, 614–615
  - saturated steam, 111
  - screw gauge, 547–549
  - screw pump, 319
  - second-generation biofuels, 66
  - second law of thermodynamics, 29–32, 240
  - self-aligning ball bearings, 424–425
  - semi-centrifugal casting, 618
  - separating and throttling calorimeter, 110
  - set hammer, 690
  - shaper, 572, 575
  - shaping and planning, 569–570
  - shaving, 670
  - shearing operations, 677–681
  - sheet metal process, 671
    - hand tools used, 673–677
    - joints, 671–672
    - materials used, 672–673
  - shellac bond, 588
  - shell mold, 606
  - shielded metal arc welding (SMAW), 633–634
  - shoulder turning, 565
  - side milling, 583
  - sign convention
    - for heat and work interaction, 13
    - work done by system, 11
  - silica, 525
  - silicate bond, 587–588
  - silicon (Si), 521
  - sine bar, 551–552
  - sintering, 684
  - skin dried sand mold, 605–606
  - slab milling, 582
  - slip gauges, 549–551
  - slotter machine, 571
  - smith's forge or hearth, 686
  - smithy, 685–686
    - tools used in, 686–691
  - smoothers, 690
  - solar energy, 89–90
  - soldering, 645–646
  - solid biofuels, 65–66
  - solid fuels, 58
  - specific fuel consumption, 210
  - specific heat capacity
    - at constant pressure, 8–10
    - at constant volume, 8
  - specific humidity, 253

- specific power output, 210
  - specific volume, 254
  - spherical roller bearings, 426
  - spheroidizing, 720
  - split air conditioner, 266–267
  - spinning, 569
  - springs
    - applications of, 406–407
    - materials used for, 409–410
    - types of, 407–409
  - spur gears, 476
  - statistical thermodynamics, 1
  - steady and unsteady flow, 284
  - steady flow energy equation (SFEE), 25
  - steady flow process, 24–25
  - steam
    - at constant pressure, 97–101
    - entropy of, 101
    - Mollier diagram of, 727
    - P-V diagram, T-S diagram, h-S diagram, P-S diagram, 99–100
    - table, 111, 728–738
    - wet, 100
  - steam engine, 141–147
  - steam generators, 112–118
  - steam power system, 141
  - steam separator, 128
  - steam trap, 128
  - steam turbine
    - classification of, 147–151
    - governing of, 164
    - losses in, 164
  - Stefan–Boltzmann Law of Thermal Radiation, 228
  - straddle milling, 584
  - straight turning, 565
  - strain gauges, 540–541
  - strain measurement, 539–541
  - stress and strain, 377–379
    - in an assembly of tube and bolt, 387
    - in composite bar, 392
    - in compound bar, 386–387
    - diagram, 378–379, 381
    - due to suddenly applied load, 394–395
    - for impact load, 395
    - relation between stress and volumetric strain, 396–397
    - in taper rod, 383–384
    - in varying cross-section bar of uniform strength, 385
  - stretch forming operation, 678
  - submerged arc welding (SAW), 636–637
  - suction stroke, 189–191
  - sulfur oxide, 212
  - sulfur (S), 521
  - superheated steam, 111
  - superheater, 127
  - surface grinding, 589
  - surface tension, 277–278
  - swage block, 688–689
  - swages, 691
  - syngas, 65
  - synthetic hydrocarbon fuels, 58
  - system
    - boundary of, 6
    - defined, 3, 5
    - properties of, 3–4
  - system boundary, 3
- T**
- tangential thrust, 150
  - tapered roller bearings, 426
  - taper turning, 566
  - tapping, 568
  - temperature, 6
    - measurement, 530–531
    - stress, 393
  - tempering, 721–722
  - theorem of parallel axis, 361
  - theorem of perpendicular axis, 361
  - thermal equilibrium, 4–5
  - thermal power plants, 75–76
  - thermit welding, 645
  - thermocouple, 530
  - thermodynamic cycle, 5
  - thermodynamic temperature scale, 6
  - thermoplastics, 524
  - thermosetting plastics, 524
  - third law of thermodynamics, 41–45
  - thread cutting, 567–568
  - thread rolling, 668–669
  - three-screw, high-pitch, screw pump, 319–320
  - throttling calorimeter, 108–109
  - thrust ball bearings, 425
  - tidal barrage, 82
  - tidal fences, 84
  - tidal power plant, 82–85
    - advantages, 84
    - disadvantages, 85
  - tidal turbine, 83

timber, 524  
 time-temperature-transformation curves, 718–719  
 titanium alloys, 523  
 tongs, 689  
 torque measurement, 543–545  
 torsion springs, 408  
 trimming, 670  
 true centrifugal casting, 617–618  
 tube drawing, 666–667  
 tungsten inert gas arc welding (TIG)/gas tungsten arc welding (GTAW), 635–636  
 tungsten (W), 522  
 two-screw, low-pitch, screw pump, 319  
 two-stroke C.I. engine, 194–196  
 two-stroke spark ignition engine, 192–194  
   port timing diagram for, 198–199

## U

uncertainty of measurement, 546  
 uniform and non-uniform flow, 284  
 universal cylindrical grinder, 591  
 universal gas constant, 45  
 universal joints, 487–488  
 up milling, 582  
 upset forging, 662–663  
 U-tube manometer, 535

## V

vanadium (V), 522  
 vane pump, 318  
 vapor compression refrigeration system, 247–250  
   advantages and disadvantages, 250  
   comparison between reversed Carnot cycle, 249  
   COP of, 248  
   factors affecting performance, 249  
   heat and work interaction in, 247  
   thermodynamic process of, 247–248  
 variable flow process, 25  
 vegetable oil, 65  
 velocity measurement, 535  
 Vernier calipers, 546–547  
 vertical boiler, 113  
 Vickers hardness test, 517  
 vitrified bond, 587  
 volatile organic compounds, 212  
 volatility, 60  
 volume  
   defined, 3  
   measurement, 535–536  
 volumetric efficiency, 210

## W

water content of furnace oil, 61  
 water tube boilers, 112–113  
 weldability, 622–623  
 welding  
   atomic hydrogen, 638–639  
   carbon arc, 633  
   classification, 624  
   defects, 648–649  
   defining, 622–623  
   electric arc, 629–632  
   electroslag, 637–638  
   flash, 643–644  
   gas, 625–628  
   metal inert gas arc (MIG)/gas metal arc (GMAW), 634–635  
   percussion, 644  
   plasma arc, 639–640  
   resistance, 640  
   resistance butt, 645  
   resistance projection, 642–643  
   resistance seam, 642  
   resistance spot, 641–642  
   shielded metal arc (SMAW), 633–634  
   submerged arc (SAW), 636–637  
   tungsten inert gas arc (TIG)/gas tungsten arc (GTAW), 635–636  
   type of groove or edge preparation for, 623–624  
 wet bulb temperature or saturation temperature (WBT), 254  
 wet steam, 100  
 white cast iron, 520  
 windmill, 87–89  
 window air conditioner, 265–267  
 wind power, 90  
 wire drawing, 665–666  
 work  
   defined, 7  
   similarities between heat and, 13  
 working fluid, 86  
 worm gears, 478

## Z

zeroth law of thermodynamics, 6

*This page is intentionally left blank.*

*This page is intentionally left blank.*



*This page is intentionally left blank.*